

PRODUCT NO
SEE TABLE

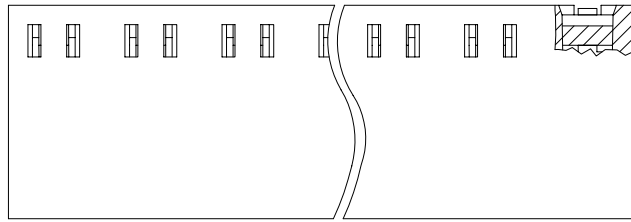

OPTIONAL INSULATION PLUG

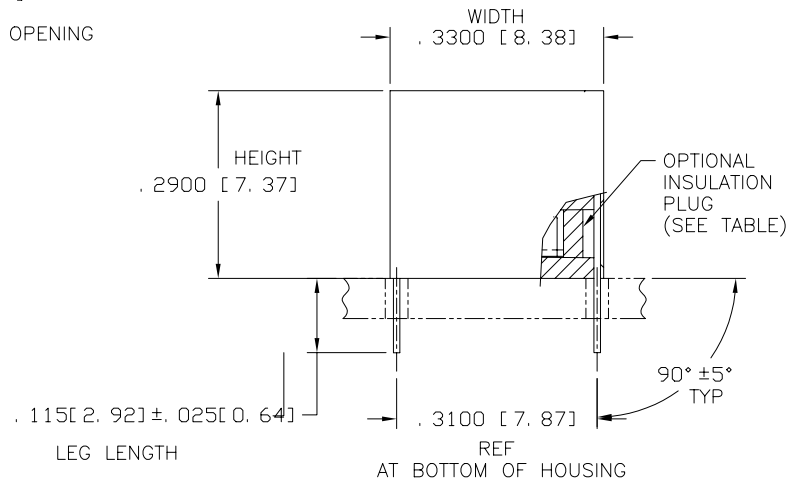
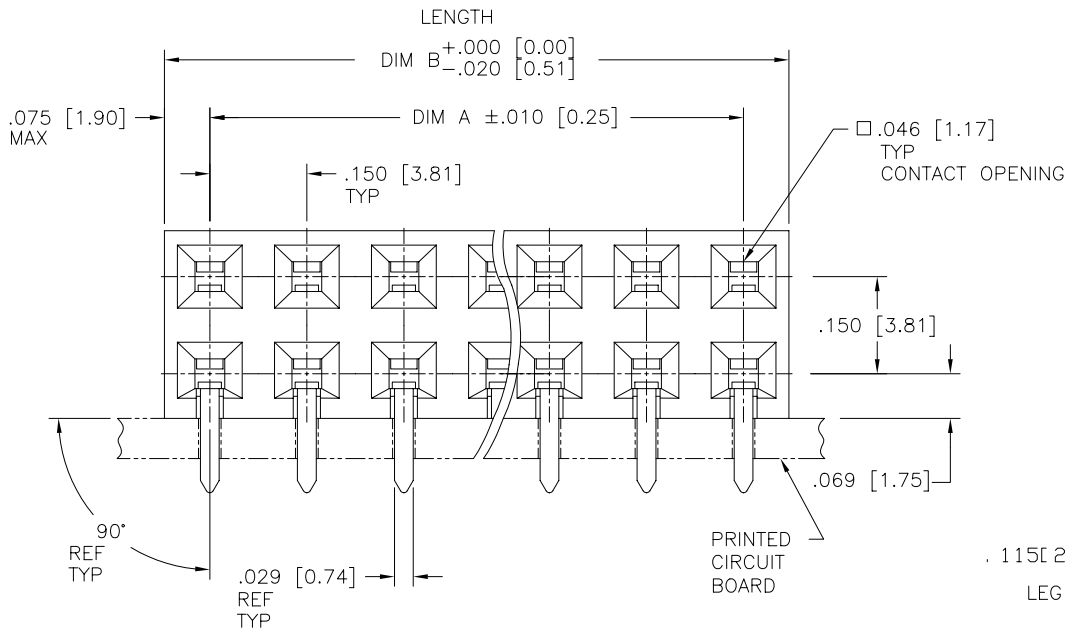

FCI
FCIconnect.com

Copyright FCI

mat'l. code		surface		tolerance		projection		product family	
-		ISO 1302 ✓		ISO 406 ISO 1101				CARD CONN	
ltr	ecn	no	dr	date	tolerances unless otherwise specified		title		
F	REDRAWN	JRL	6/3/85		angles	.xx±.01/.3	BERGCON HORIZ. CARD CONN.		
G	v40328	MSC	3/30/94		linear	.xxx ±.005/.13	DOUBLE ROW .150/3.81		
H	v61666	LSS	12/20/96	0'±2'		.xxx ±.0020/.051	scale 4:1		
J	v70997	EPK	9/24/97	dr	JIM LINN	11/18/85	dwg no		
K	v02518	MDF	10/31/00	enfr	R. HOFFMAN	11/18/85	sheet 1 of 6 size		
L	M05-0181	MHT	8/17/05	chr	H. SUNDY	3/30/94	67210 A3		
M	M06-0117	AEA	06/26/06	appd	R. HOFFMAN	11/25/85	type Product Customer Drawing		
sheet	revision	M	M	M	M	M	M		
index	sheet	1	2	3	4	5	6		

form: A3

PRODUCT NO

SEE TABLE

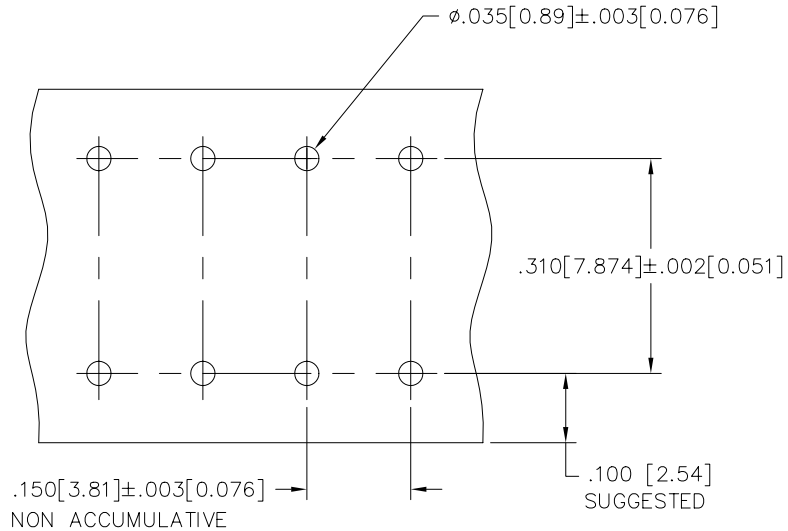

FIGURE 1

NOTES:

- ① HOUSING MATERIAL: FILLED HIGH TEMPERATURE NYLON
COLOR: BLACK
- ② TERMINAL MATERIAL:
BODY: 1/4 HARD BRASS. .010/0.25 THICK – ALLOY 260
SPRING: BE – CU. HEAT TREATED. ALLOY 172
BODY PLATING: 30u"/0.76u GOLD OVER
50u"/1.27u NICKEL IN CONTACT AREA
SPRING PLATING: GOLD FLASH
3. APPLICATION INFORMATION:
A. RECOMMENDED MOUNTING HOLE PATTERN IS SHOWN AT LEFT.
B. ALL MATING PINS TO BE .025/0.84 SQUARE ON TRUE CENTER OF GIVEN TERMINAL SPACING WITHIN .015/0.38 DIA.
C. SUGGESTED MATING PIN LENGTH .350±.020/8.89±0.51.
- ④ ADD "LF" SUFFIX AT THE END OF PART NUMBER FOR LEAD FREE OPTION.
- ⑤ THESE PRODUCT MEETS EUROPEAN UNION DIRECTIVES AND OTHER COUNTRY REGULATIONS AS DESCRIBED IN GS-22-008
6. THIS PART WILL WITHSTAND EXPOSURE TO 260°C PEAK TEMPERATURE FOR 20 SECONDS IN A WAVE SOLDER, INFRA-RED OR VAPOR PHASE SOLDER PROCESS.



FCIconnect.com

Copyright FCI

mat'l. code		surface		tolerance		projection		product family	
-		ISO 1302 ✓		ISO 406 ISO 1101		⊕		CARD CONN	
ltr	ecn	no	dr	date	tolerances unless otherwise specified				
M					angles	linear	.xx±.01/.3	INCH/MM	
					0'±2'		.xxx ±.005/.13	BERGCON HORIZ. CARD CONN.	
							.xxx ±.0020/.051	DOUBLE ROW .150/3.81	
					dr	JIM LINN	11/18/85	scale 4:1	
					enr	R. HOFFMAN	11/18/85	dwg no	
					chr	H. SUNDY	3/30/94	sheet 2 of 6 size	
					appd	R. HOFFMAN	11/25/85	67210 A3	
sheet		revision		type					
index		sheet		Product Customer Drawing					

PRODUCT NO	NO. OF POS.	DIM A	DIM B	INSULATION PLUG	SPECIAL MARKINGS	LEAD FREE OPTION
67210-001	2X1	.00/0.0	.150/3.81	NO		NOTE 5,6
-002	2X2	.150/3.81	.300/7.62	NO		
-003	2X3	.300/7.62	.450/11.43			
-004	2X4	.450/11.43	.600/15.24			
-005	2X5	.600/15.24	.750/19.05			
-006	2X6	.750/19.05	.900/22.86			
-007	2X7	.900/22.86	1.050/26.67			
-008	2X8	1.050/26.67	1.200/30.48			
-009	2X9	1.200/30.48	1.350/34.29			
-010	2X10	1.350/34.29	1.500/38.10			
-011	2X11	1.500/38.10	1.650/41.91			
-012	2X12	1.650/41.91	1.800/45.72			
-013	2X13	1.800/45.72	1.950/49.53			
-014	2X14	1.950/49.53	2.100/53.34			
-015	2X15	2.100/53.34	2.250/57.15			
-016	2X16	2.250/57.15	2.400/60.96			
-017	2X17	2.400/60.96	2.550/64.77			
-018	2X18	2.550/64.77	2.700/68.58			
-019	2X19	2.700/68.58	2.850/72.39			
-020	2X20	2.850/72.39	3.000/76.20			
-021	2X21	3.000/76.20	3.150/80.01			
-022	2X22	3.150/80.01	3.300/83.82			
-023	2X23	3.300/83.82	3.450/87.63			
-024	2X24	3.450/87.63	3.600/91.44			
67210-025	2X25	3.600/91.44	3.750/95.25	NO		NOTE 5,6



FCJconnect.com

Copyright FCJ

mat'l. code		surface		tolerance		projection		product family	
-		ISO 1302		ISO 406		1st angle		CARD CONN	
ltr		ecn		no		dr		date	
M									
				tolerances unless otherwise specified		INCH/MM		title	
				.xx±.01/.3				BERGCON HORIZ. CARD CONN.	
				.xxx ±.005/.13				DOUBLE ROW .150/3.81	
				0'±2'		scale 4:1		sheet no	
								3 of 6	
				dr		JIM LINN		11/18/85	
				enfr		R. HOFFMAN		11/18/85	
				chr		H. SUNDY		3/30/94	
				appd		R. HOFFMAN		11/25/85	
sheet		revision							
index		sheet							



form: A3 1 2 3 4 5 6

PRODUCT NO	NO. OF POS.	DIM A	DIM B	INSULATION PLUG	SPECIAL MARKINGS	LEAD FREE OPTION
67210-026	2X26	3.750/95.25	3.900/99.06	NO		NOTE 5,6
-027	2X27	3.900/99.06	4.050/102.87			
-028	2X28	4.050/102.87	4.200/106.68			
-029	2X29	4.200/106.68	4.350/110.49			
-030	2X30	4.350/110.49	4.500/114.30			
-031	2X31	4.500/114.30	4.650/118.11			
-032	2X32	4.650/118.11	4.800/121.92			
-033	2X33	4.800/121.92	4.950/125.73			
-034	2X34	4.950/125.73	5.100/129.54			
-035	2X35	5.100/129.54	5.250/133.35			
-036	2X36	5.250/133.35	5.400/137.16			
-037	2X37	5.400/137.16	5.550/140.97			
-038	2X38	5.550/140.97	5.700/144.78			
-039	2X39	5.700/144.78	5.850/148.59			
-040	2X40	5.850/148.59	6.000/152.40			
-041	2X41	6.000/152.40	6.150/156.21			
-042	2X42	6.150/156.21	6.300/160.02			
67210-043	2X43	6.300/160.02	6.450/163.83	NO		NOTE 5,6



Copyright FCI

mat'l. code		surface		tolerance		projection		product family	
-		ISO 1302		ISO 406		1st angle		CARD CONN	
ltr		ecn no		date		tolerances unless otherwise specified		title	
M						.xx±.01/.3		BERGCON HORIZ. CARD CONN.	
						.xxx ±.005/.13		DOUBLE ROW .150/3.81	
						.xxx ±.0020/.051		scale 4:1	
						dr		JIM LINN 11/18/85	
						enr		R. HOFFMAN 11/18/85	
						chr		H. SUNDY 3/30/94	
						appd		R. HOFFMAN 11/25/85	
sheet index		revision sheet						FCJ	
								dwg no 67210 sheet 4 of 6 size A3	
								type Product Customer Drawing	

form: A3 1 2 3 4 5 6

PRODUCT NO	NO. OF POS.	DIM A	DIM B	INSULATION PLUG	SPECIAL MARKINGS	LEAD FREE OPTION
67210-501	2X1	.00/.0	.150/3.81	YES		NOTE 5,6
-502	2X2	.150/3.81	.300/7.62	YES		OBS.
-503	2X3	.300/7.62	.450/11.43			
-504	2X4	.450/11.43	.600/15.24			
-505	2X5	.600/15.24	.750/19.05			
-506	2X6	.750/19.05	.900/22.86			
-507	2X7	.900/22.86	1.050/26.67			
-508	2X8	1.050/26.67	1.200/30.48			
-509	2X9	1.200/30.48	1.350/34.29			
-510	2X10	1.350/34.29	1.500/38.10			
-511	2X11	1.500/38.10	1.650/41.91			
-512	2X12	1.650/41.91	1.800/45.72			
-513	2X13	1.800/45.72	1.950/49.53			
-514	2X14	1.950/49.53	2.100/53.34			
-515	2X15	2.100/53.34	2.250/57.15			
-516	2X16	2.250/57.15	2.400/60.96			
-517	2X17	2.400/60.96	2.550/64.77			
-518	2X18	2.550/64.77	2.700/68.58			
-519	2X19	2.700/68.58	2.850/72.39			
-520	2X20	2.850/72.39	3.000/76.20			
-521	2X21	3.000/76.20	3.150/80.01			
-522	2X22	3.150/80.01	3.300/83.82			
-523	2X23	3.300/83.82	3.450/87.63			
-524	2X24	3.450/87.63	3.600/91.44			
67210-525	2X25	3.600/91.44	3.750/95.25	YES		



FCJconnect.com

Copyright FCJ

mat'l. code		surface		tolerance		projection		product family	
-		ISO 1302 <input checked="" type="checkbox"/>		ISO 406				CARD CONN	
ltr		ecn		no		dr		date	
M									
				tolerances unless otherwise specified		INCH/MM		title	
				.xx±.01/.3		scale 4:1		BERGCON HORIZ. CARD CONN.	
				.xxx ±.005/.13				DOUBLE ROW .150/3.81	
				.xxx ±.0020/.051				dwg no	
				0'±2'				sheet 5 of 6 size	
				dr		JIM LINN		11/18/85	
				enr		R. HOFFMAN		11/18/85	
				chr		H. SUNDY		3/30/94	
				appd		R. HOFFMAN		11/25/85	
sheet		revision							
index		sheet							



form: A3 1 2 3 4 5 6

PRODUCT NO	NO. OF POS.	DIM A	DIM B	INSULATION PLUG	SPECIAL MARKINGS	LEAD FREE OPTION
67210-526	2X26	3.750/95.25	3.900/99.06	YES		NOTE 5,6
-527	2X27	3.900/99.06	4.050/102.87			
-528	2X28	4.050/102.87	4.200/106.68			
-529	2X29	4.200/106.68	4.350/110.49			
-530	2X30	4.350/110.49	4.500/114.30			
-531	2X31	4.500/114.30	4.650/118.11			
-532	2X32	4.650/118.11	4.800/121.92			
-533	2X33	4.800/121.92	4.950/125.73			
-534	2X34	4.950/125.73	5.100/129.54			
-535	2X35	5.100/129.54	5.250/133.35			
-536	2X36	5.250/133.35	5.400/137.16			
-537	2X37	5.400/137.16	5.550/140.97			
-538	2X38	5.550/140.97	5.700/144.78			
-539	2X39	5.700/144.78	5.850/148.59			
-540	2X40	5.850/148.59	6.000/152.40			
-541	2X41	6.000/152.40	6.150/156.21			
-542	2X42	6.150/156.21	6.300/160.02			
-543	2X43	6.300/160.02	6.450/163.83	YES		
-800	2X23	3.300/83.82	3.450/87.63	NO	503009-8 "LITTON"	
-801	2X30	4.350/110.49	4.500/114.30		503009-9 "LITTON"	
-802	2X41	6.000/152.40	6.150/156.21		503009-10 "LITTON"	
67210-803	2X42	6.150/156.21	6.300/160.02	NO	503009-12 "LITTON"	NOTE 5,6



FCIconnect.com

Copyright FCI

mat'l. code		surface		tolerance		projection		product family	
-		ISO 1302		ISO 406		1st angle		CARD CONN	
ltr		ecn		no		dr		date	
M									
		angles		linear		INCH/MM		title	
		0°±2'		.xxx ±.005/.13		scale 4:1		BERGCON HORIZ. CARD CONN.	
				.xxxx ±.0020/.051				DOUBLE ROW .150/3.81	
		dr		JIM LINN		11/18/85		dwg no	
		enrg		R. HOFFMAN		11/18/85		sheet 6 of 6 size	
		chr		H. SUNDY		3/30/94		67210	
		appd		R. HOFFMAN		11/25/85		A3	
sheet index		revision sheet						type Product Customer Drawing	

