

Technical specification:

Technische Daten:

Working voltage/ Betriebsspannung:	100 VDC
Current rating/ Strombelastbarkeit:	7,5 A (UL) / 5 A (CSA,VDE)
Insulation resistance/ Isolationswiderstand:	≥ 1 GΩ
Dielectric withstanding voltage/ Spannungsfestigkeit (DWV):	424 VDC
Temperature working range/ Umgebungstemperatur:	- 25 °C ... + 105 °C
Capacitance value/ Kapazitätswert:	1300 pF ± 20 %
Mating cycles/ Steckzyklen:	Quality class 1 = 500 Gütestufe 1 Quality class 2 = 200 Gütestufe 2 Quality class 3 = 50 Gütestufe 3

Materials/

Werkstoffe:

Contact/ Kontakt:	Cu alloy, Au over Ni Contact tails pretinned/ Kontaktspitzen verzinkt
Insulator/ Isolierkörper:	High temp. PA UL94 V-0
Shells/ Gehäuse:	Steel, Sn over Ni
Threaded rear spacer PCB-clip/ Gewinde Abstandsbolzen PCB-Clip:	Cu alloy, Sn over Ni
Collar/ Scheibe:	Cu alloy, Sn over Ni

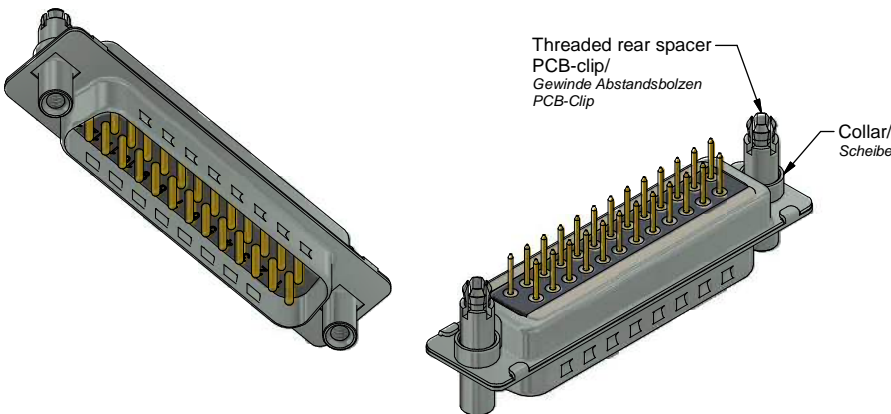

Installation specification/

Montagedaten:

Solder parameter/ Lötparameter:	
Solder preheat temperature/ Vorheiztemperatur:	100 °C for 30 sec./ 100 °C für 30 sek.
Solder bath temperature/ Lötbadtemperatur:	260 °C for 5 sec./ 260 °C für 5 sek.
Recommended torque value for thread/ Empfohlenes Drehmoment für Gewinde:	max. 6 in.LB/ max. 67 Ncm
PCB Clip for hole diameter/ PCB Snap für Lochdurchmesser:	Ø3,1 mm
Circuit board thickness/ Leiterplattenstärke:	1,6 mm

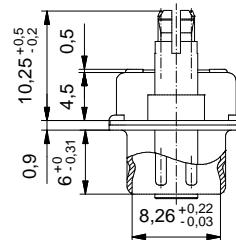
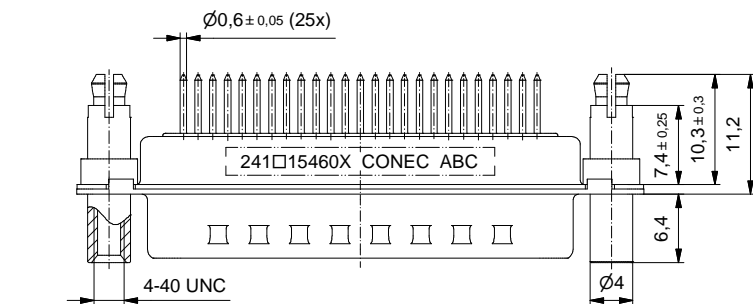
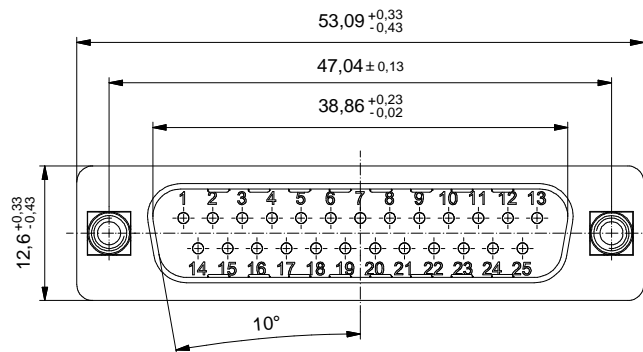

Part no. / Part marked / Art.-Nr. / Bedruckung:	Quality class/ Gütestufe:	Contact plating / Kontakt Veredelung:
241A15460X	3	Gold flash over nickel Gold über Nickel
241B15460X	2	20 µin hard gold over min. 50 µin nickel 20 µin Gold über min. 50 µin Nickel
241C15460X	1	30 µin hard gold over min. 50 µin nickel 30 µin Gold über min. 50 µin Nickel

Index: a Original	Scale/Maßstab: 2:1		D-SUB C-Filter Male 25pos. with threaded rear spacer PCB-clip D-SUB C-Filter Stiftleiste 25pol. mit Gewinde Abstandsbolzen PCB-Clip	dwg no / Z.-nr.: 24K1A1804	DIN- A3
Status: InBearbeitung					
RoHS compliant/konform					

The reproduction, distribution and utilization of this document as well as the communication of its contents to others without express authorization is prohibited. Offenders will be held liable for the payment of damages. Wir bitten Sie, die Weitergabe und Nutzung dieses Dokuments sowie die Kommunikation seines Inhalts an Dritte ohne unsere ausdrückliche Genehmigung zu unterlassen. Zuwiderhandlungen werden mit Schadenersatz geahndet.