



FAN25800 500 mA, Low-I_Q, Low-Noise, LDO Regulator

Features

- V_{IN}: 2.3 V to 5.5 V
- V_{OUT} = 2.7 V, 3.3 V (I_{OUT} Max. = 500 mA)
- V_{OUT} = 2.8 V (I_{OUT} Max. = 250 mA)
- Output Noise Density at 250 mA and 10 kHz = 19 nV/√Hz (Integrated 8 μV_{RMS})
- Low I_Q of 17 μA in Regulation and Low-I_Q Dropout Mode with Optimized Dropout Transitions
- <70 mV Dropout Voltage at 250 mA Load
- Controlled Soft-Start to Reduce Inrush Current
- Thermal Shutdown Protection (TSD)
- Input Under-Voltage Lockout (UVLO)
- Short-Circuit Protection (SCP)
- Stable with Two 1.5 μF, 0201 Ceramic Capacitors at V_{OUT}
- 4-Ball WLCSP, 0.65 mm x 0.65 mm, 0.35 mm Pitch, Plated Solder, 330 μm Maximum Thickness

Description

The FAN25800 is a linear low-dropout regulator with a high PSRR (85 dB at 100 Hz) and low output noise (typically 8 μV_{RMS} over a 10 Hz to 100 kHz bandwidth). The LDO can provide up to 500 mA of output current.

The enable control pin can be used to shut down the device and disconnect the output load from the input. During shutdown, the supply current drops below 1 μA.

The FAN25800 is designed to be stable with space-saving ceramic capacitors as small as 0201 case size. The FAN25800 is available in a 4-bump, 0.35 mm pitch, WLCSP package.

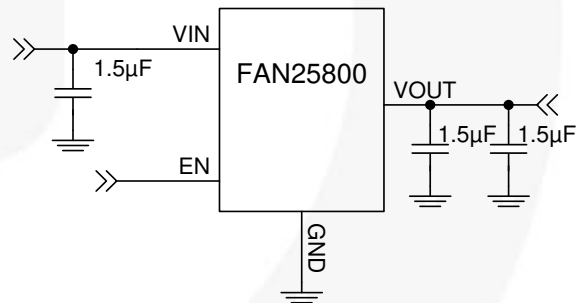

Figure 1. Typical Application

Applications

- WiFi Modules
- PDA Handsets
- Smart Phones, Tablets, Portable Devices

Ordering Information

Part Number ⁽¹⁾	V _{OUT}	I _{OUT_MAX}	Operating Temperature	Package	Packing Method
FAN25800AUC33X	3.3 V	500 mA	-40°C to 85°C	4-Bump, WLCSP, 0.65 x 0.65 mm, 0.35 mm Pitch	Tape & Reel
FAN25800AUC28X	2.8 V	250 mA			
FAN25800AUCF27X	2.7 V	500 mA			

Note:

1. For other trim options, please contact a Fairchild representative.

Block Diagram

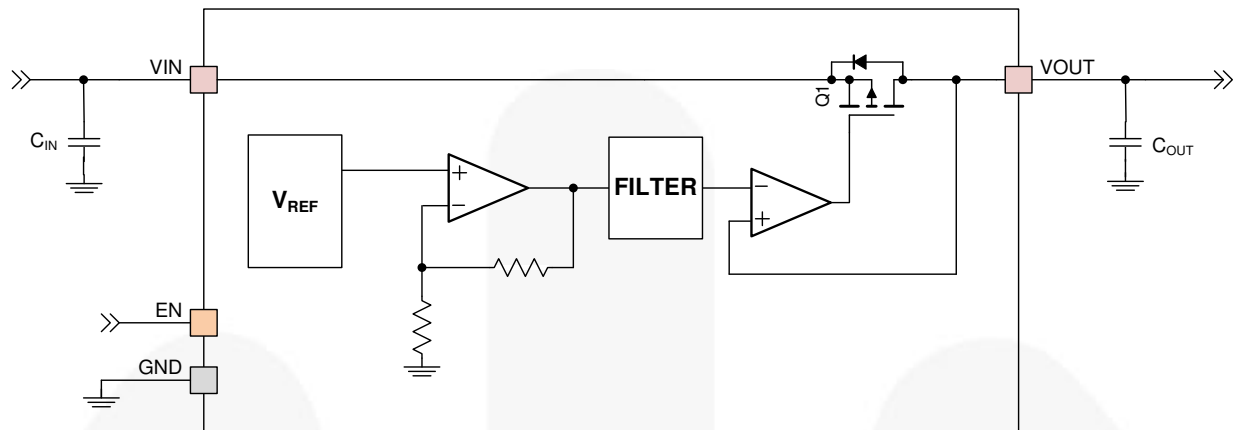

Figure 2. IC and System Block Diagram

Table 1. Recommended External Components

Component	Description	Vendor	Parameter	Typ.	Unit
C _{IN}	1.5 μF, 6.3 V, X5R, 0201	Murata GRM033R60J155M	C	1.5 ⁽²⁾	μF
C _{OUT}	2x1.5 μF, 6.3 V, X5R, 0201	Murata GRM033R60J155M		1.5 ⁽²⁾	μF
C _{Alternative} ⁽³⁾	1.0 μF, 6.3 V, X5R, 0201	Murata GRM033R60J105M		1.0 ⁽²⁾	μF

Notes:

- Capacitance value does not reflect effects of bias, tolerance, and temperature. See *Recommended Operating Conditions and Operation Description* sections for more information.
- C_{Alternative} can be used for both C_{IN} and C_{OUT}. FAN25800 is stable with one 1 μF at C_{IN} and one 1 μF at C_{OUT}.

Pin Configuration

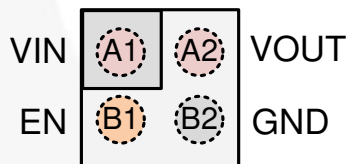

Figure 3. Top-Through View

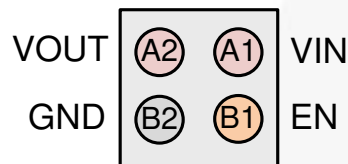

Figure 4. Bottom View

Pin Definitions

Pin #	Name	Description
A1	VIN	Input Voltage. Connect to input power source and C _{IN} .
A2	VOUT	Output Voltage. Connect to C _{OUT} and load.
B1	EN	Enable. The device is in Shutdown Mode when this pin is LOW. No internal pull-down. Do not leave this pin floating. Recommended to not tie EN pin directly to VIN. ⁽⁴⁾
B2	GND	Ground. Power and IC ground. All signals are referenced to this pin.

Note:

- Recommended to use logic voltage of 1.8 V to drive the EN pin.

Absolute Maximum Ratings

Stresses exceeding the absolute maximum ratings may damage the device. The device may not function or be operable above the recommended operating conditions and stressing the parts to these levels is not recommended. In addition, extended exposure to stresses above the recommended operating conditions may affect device reliability. The absolute maximum ratings are stress ratings only.

Symbol	Parameter	Min.	Max.	Unit
V _{IN}	Input Voltage with Respect to GND	-0.3	6.0	V
V _{CC}	Voltage on Any Other Pin (with Respect to GND)	-0.3	V _{IN} +0.3 ⁽⁵⁾	V
T _J	Junction Temperature	-40	+150	°C
T _{STG}	Storage Temperature	-65	+150	°C
T _L	Lead Soldering Temperature, 10 Seconds		+260	°C
ESD	Electrostatic Discharge Protection Level	Human Body Model, ANSI/ESDA/JEDEC JS-001-2012	4000	V
		Charged Device Model per JESD22-C101	1500	
LU	Latch Up	JESD 78D		

Note:

5. Lesser of 6.0 V or V_{IN} + 0.3 V.

Recommended Operating Conditions

The Recommended Operating Conditions table defines the conditions for actual device operation. Recommended operating conditions are specified to ensure optimal performance to the datasheet specifications. Fairchild does not recommend exceeding them or designing to absolute maximum ratings.

Symbol	Parameter	Min.	Typ.	Max.	Unit
V _{IN}	Supply Voltage	2.3		5.5 ⁽⁶⁾	V
I _{OUT_MAX} ⁽⁷⁾	Output Current (V _{OUT} = 2.7 V, 3.3 V)			500	mA
I _{OUT_Recommend}	Output Current (V _{OUT} = 3.3 V)			500	mA
	Output Current (V _{OUT} = 2.7 V, 2.8 V)			250	mA
C _{IN}	Input Capacitor (Effective Capacitance) ⁽⁸⁾	0.4	0.8		μF
C _{OUT}	Output Capacitor (Effective Capacitance) ⁽⁸⁾	0.4	0.8	15.0	μF
T _A	Ambient Temperature	-40		+85	°C
T _J	Junction Temperature	-40		+125	°C

Note:

6. For V_{IN} ≥ 3.4 V, thermal properties of the device must be taken into account at maximum load of 500 mA; refer to θ_{JA} thermal properties.
7. I_{OUT_MAX} is for V_{IN} = V_{OUT} + 0.3 V.
8. Effective capacitance, including the effects of bias, tolerance, and temperature. See the Operation Description section for more information.

Thermal Properties

Junction-to-ambient thermal resistance is a function of application and board layout. This data is measured with four-layer 2s2p boards in accordance to JEDEC standard JESD51. Special attention must be paid not to exceed junction temperature, T_{J(max)}, at a given ambient temperature, T_A.

Symbol	Parameter	Typ.	Unit
θ _{JA}	Junction-to-Ambient Thermal Resistance	180	°C/W

Electrical Specifications

Minimum and maximum values are at $V_{IN} = V_{OUT} + 0.3\text{ V}$; $T_A = -40^\circ\text{C}$ to $+85^\circ\text{C}$; and test circuit shown in Figure 1. Typical values are at $V_{IN} = V_{OUT} + 0.3\text{ V}$, $T_A = 25^\circ\text{C}$, $I_{LOAD} = 10\text{ mA}$, and $V_{EN} = 1.8\text{ V}$, unless otherwise noted.

Symbol	Parameter	Conditions	Min.	Typ.	Max.	Unit	
LDO							
I_{IN}	V_{IN} Supply Current	$V_{IN} = V_{OUT} + 0.3\text{ V}$ to 4.2 V , $I_{LOAD} = 0\text{ mA}$		17.0	25.0	μA	
		Dropout ⁽¹⁰⁾ , $I_{LOAD} = 0\text{ mA}$		18.5	30.0		
PSRR	Power Supply Rejection Ratio ⁽⁹⁾	$I_{OUT} = 10\text{ mA}$, $V_{IN} = 3.6\text{ V}$, $V_{OUT} = 3.3\text{ V}$	$f = 50\text{ Hz}$		84	dB	
			$f = 100\text{ Hz}$		85		
			$f = 1\text{ kHz}$		84		
			$f = 10\text{ kHz}$		79		
		$I_{OUT} = 250\text{ mA}$, $V_{IN} = 3.6\text{ V}$, $V_{OUT} = 3.3\text{ V}$	$f = 50\text{ Hz}$		68		
			$f = 100\text{ Hz}$		73		
			$f = 1\text{ kHz}$		75		
			$f = 10\text{ kHz}$		76		
e_n	Output Noise Voltage Density ⁽⁹⁾	$f = 10\text{ kHz}$, $V_{OUT} = 3.3\text{ V}$	$I_{OUT} = 10\text{ mA}$		20	40	nV/ $\sqrt{\text{Hz}}$
			$I_{OUT} = 250\text{ mA}$		19	39	
e_{n_bw}	Output Noise Voltage (Integrated) ⁽⁹⁾	$f = 10\text{ Hz} - 100\text{ kHz}$, $V_{OUT} = 3.3\text{ V}$	$I_{OUT} = 10\text{ mA}$		8	25	μV_{RMS}
			$I_{OUT} = 250\text{ mA}$		8	25	
V_{DO}	V_{OUT} Dropout Voltage ⁽¹⁰⁾	$V_{OUT} = V_{OUT_TARGET} - 100\text{ mV}$, $I_{OUT} = 250\text{ mA}$		70	130	mV	
ΔV_{OUT}	V_{OUT} Voltage Accuracy	$5\text{ mA} \leq I_{OUT} \leq I_{OUT_RECOMMEND}$, $V_{IN} = V_{OUT} + 0.3\text{ V}$ to 4.2 V	-1.9		+1.9	%	
ΔV_{OUT_LOAD}	Load Regulation	$I_{OUT} = 5\text{ mA}$ to I_{OUT_MAX}		12	35	$\mu\text{V}/\text{mA}$	
I_{LIM}	V_{OUT} Current Limit	$I_{OUT} = 0\text{ mA} \rightarrow$ Current Limit, $V_{OUT} = 3.3\text{ V}$, 2.7 V , V_{OUT} Drops by 2%	550	650	800	mA	
		$I_{OUT} = 0\text{ mA} \rightarrow$ Current Limit, $V_{OUT} = 2.8\text{ V}$, V_{OUT} Drops by 2%	275	323	400		
I_{SD}	Shutdown Supply Current	$V_{EN} = 0\text{ V}$, $V_{IN} = V_{OUT} + 0.3\text{ V}$ to 4.2 V		0.125	1.000	μA	
V_{UVLO}	Under-Voltage Lockout Threshold	Rising V_{IN}		2.1	2.3	V	
V_{UVHYS}	Under-Voltage Lockout Hysteresis			150		mV	
t_{START}	Startup Time	Rising EN to 95% V_{OUT} , $I_{OUT} = 10\text{ mA}$		250	500	μs	
TSD	Thermal Shutdown	Rising Temperature		150		$^\circ\text{C}$	
		Hysteresis		20			
Logic Levels: EN							
V_{IH}	Enable High-Level Input Voltage		1.05			V	
V_{IL}	Enable Low-Level Input Voltage				0.4	V	
I_{EN}	Input Bias Current	$V_{EN} = 1.8\text{ V}$		0.04	1.00	μA	

Notes:

9. Guaranteed by design; not tested in production.
10. Dropout voltage = $V_{IN} - V_{OUTX}$ when V_{OUT} drops more than 100 mV below the nominal regulated V_{OUT} level.

Typical Characteristics

Unless otherwise specified; $V_{IN} = 3.6\text{ V}$, $V_{OUT} = 3.3\text{ V}$, $T_A = +25^\circ\text{C}$, and test circuit per Figure 1.

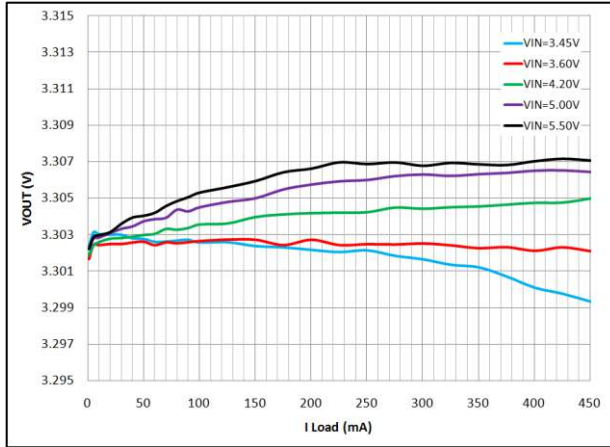

Figure 5. Output Regulation vs. Load Current and Input Voltage

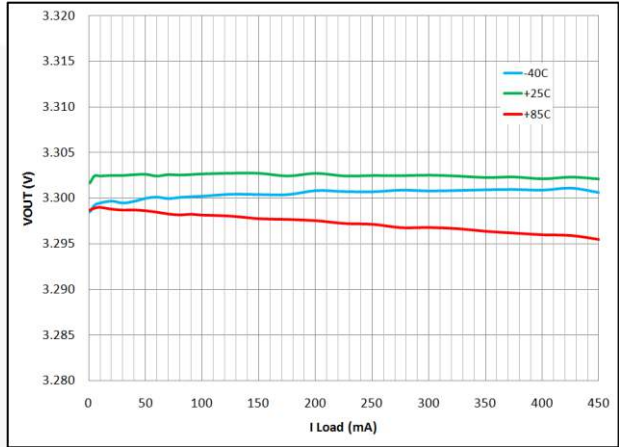

Figure 6 Output Regulation vs. Load Current and Temperature

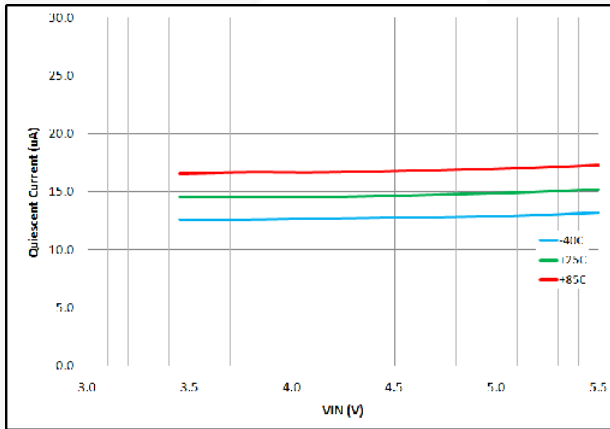

Figure 7. Quiescent Current vs. Input Voltage and Temperature

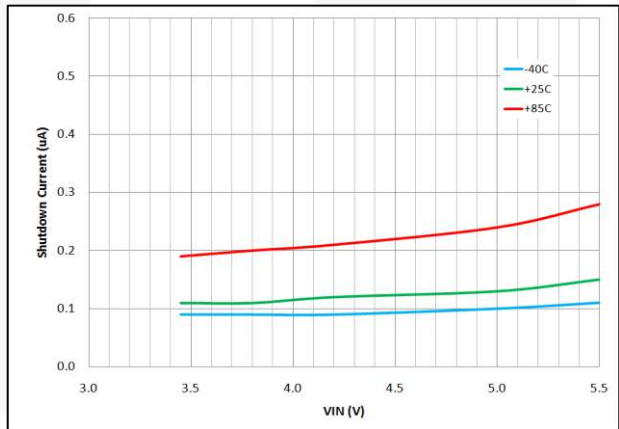

Figure 8. Shutdown Current vs. Input Voltage and Temperature

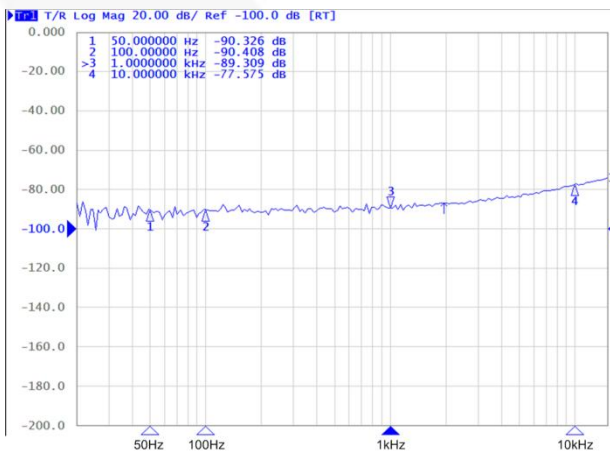

Figure 9. PSRR vs. Frequency, 10 mA Load

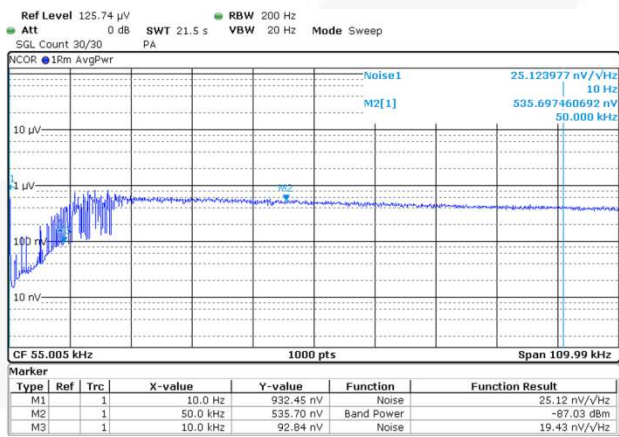

Figure 10. Output Noise Voltage vs. Frequency, 10 mA Load

Typical Characteristics

Unless otherwise specified; $V_{IN} = 3.6\text{ V}$, $V_{OUT} = 3.3\text{ V}$, $T_A = +25^\circ\text{C}$, and test circuit per Figure 1.

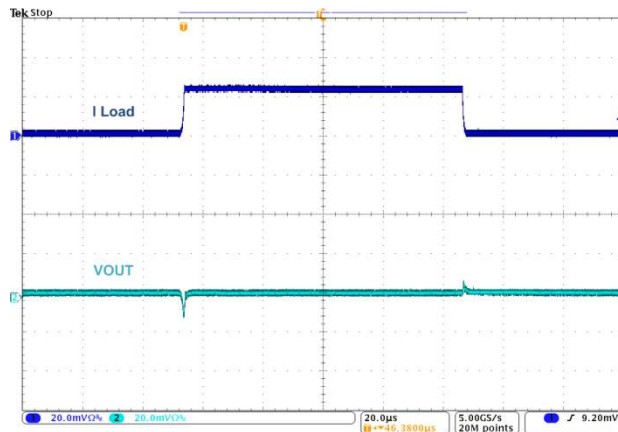

Figure 11. Load Transient, $I_{OUT} = 10 \rightarrow 250 \rightarrow 10\text{ mA}$, $V_{IN}=3.6\text{ V}$, 400 ns Edge

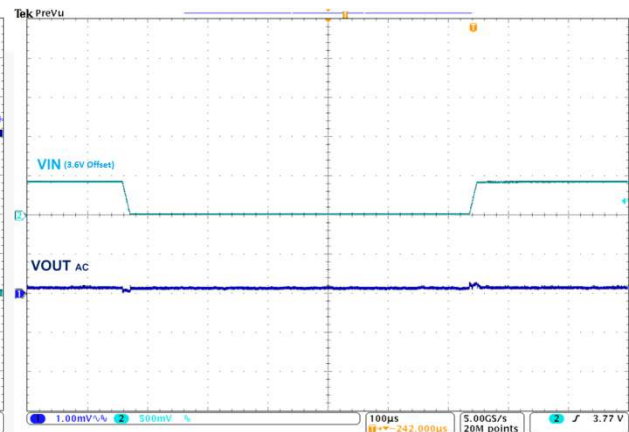

Figure 12. Line Transient, $V_{IN} = 4.0 \rightarrow 3.6 \rightarrow 4.0\text{ V}$, 10 μs Transitions, 10 mA Load

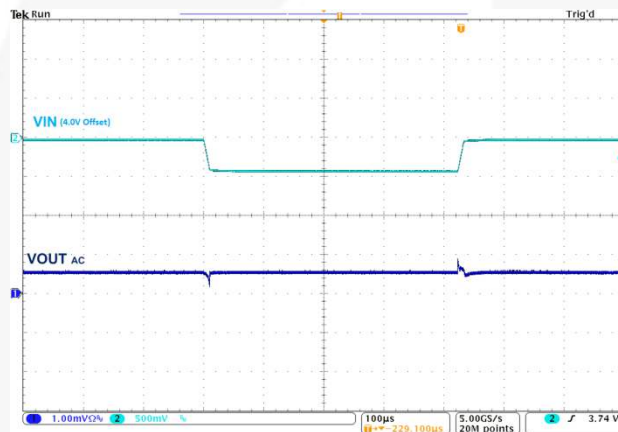

Figure 13. Line Transient, $V_{IN} = 4.0 \rightarrow 3.6 \rightarrow 4.0\text{ V}$, 10 μs Transitions, 250 mA Load

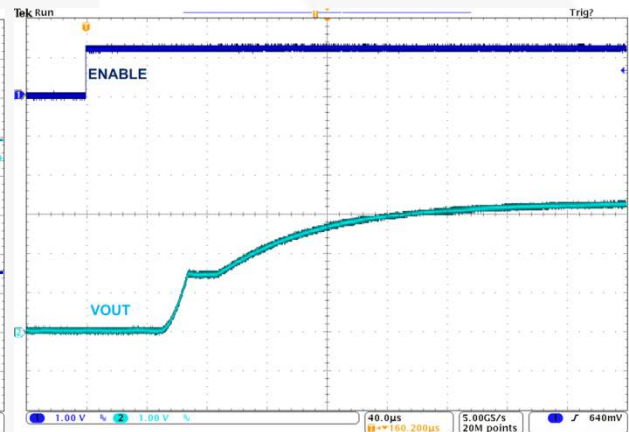

Figure 14. Startup, 10 mA Load

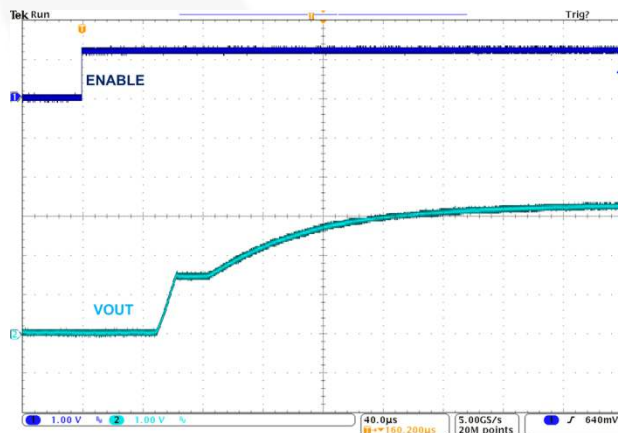

Figure 15. Startup, 250 mA Load

Circuit Description

The FAN25800 is a linear low-dropout (LDO) regulator that has high PSRR and low output noise. The enable control pin can be used to shut down the device and disconnect the output load from the input. During shutdown, the supply current drops below 1 μA. The LDO is designed to be stable with space-saving ceramic capacitors as small as 0201 case size.

Enable and Soft-Start

When EN is LOW, all circuits are off and the IC draws <550 nA of current. The EN pin does not have an internal pull-down resistor and must not be left floating. When EN is HIGH and V_{IN} is above the UVLO threshold, the regulator begins a soft-start cycle for the output. The soft-start cycle controls inrush current, limiting it to the I_{LIM} peak current limit.

Short-Circuit and Thermal Protection

The output current is short-circuit protected. When an output fault occurs, the output current is automatically limited to I_{LIM} and V_{OUT} drops. The resultant V_{OUT} is equal to I_{LIM} multiplied by the fault impedance.

Short-circuit fault or output overload may cause the die temperature to increase and exceed the maximum rating due to power dissipation. In such cases (depending upon the ambient temperature; the V_{IN}, load current, and thermal resistance (θ_{JB}) of the mounted die), the device may enter thermal shutdown.

If the die temperature exceeds the thermal shutdown temperature threshold, the onboard thermal protection disables the output until the temperature drops below its hysteresis value. At that point, the output is re-enabled and a new soft-start sequence occurs.

Thermal Considerations

For best performance, the die temperature and the power dissipated should be kept at moderate values. The maximum power dissipated can be evaluated based on the following relationship:

$$P_{D(max)} = \left\{ \frac{T_{J(max)} - T_A}{\Theta_{JA}} \right\} \quad (1)$$

where T_{J(max)} is the maximum allowable junction temperature of the die; T_A is the ambient operating temperature; and θ_{JA} is dependent on the surrounding PCB layout and can be improved by providing a heat sink of surrounding copper ground.

The addition of backside copper with through-holes, stiffeners, and other enhancements can help reduce θ_{JA}. The heat contributed by the dissipation of devices nearby must be included in design considerations.

Capacitor Selection

An output capacitor with an effective capacitance between 400 nF and 15 μF is required for loop stability. The ESR value should be within 3 to 100 mΩ. DC bias

characteristics of the capacitors must be considered when selecting the voltage rating and the case size of the capacitor. Figure 16 is a typical derating curve for a 0201 case size, 1.5 μF, 6.3 V, X5R capacitor.

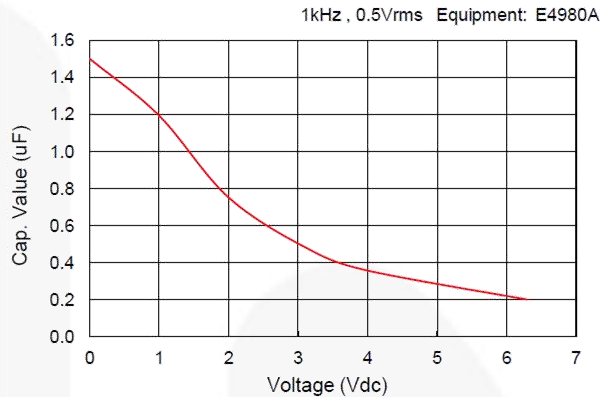

Figure 16. Capacitor DC Bias Characteristics

Typical Application for Post Regulation

Due to its high PSRR and low output noise, the FAN25800 can be used as a post-DC-DC regulator to reduce output ripple and output noise at high efficiency for noise-sensitive applications. Figure 17 shows a post-DC-DC regulation of the LDO with a buck converter. The capacitor on the output of the buck converter can be shared by the LDO as its input capacitor.

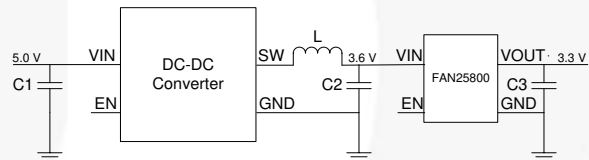

Figure 17. LDO as Post DC-DC Regulator

PCB Layout Recommendations

Capacitors should be placed as close to the IC as possible. All power and ground pins should be routed to their capacitors using top copper. The copper area connecting to the IC should be maximized to improve thermal performance.

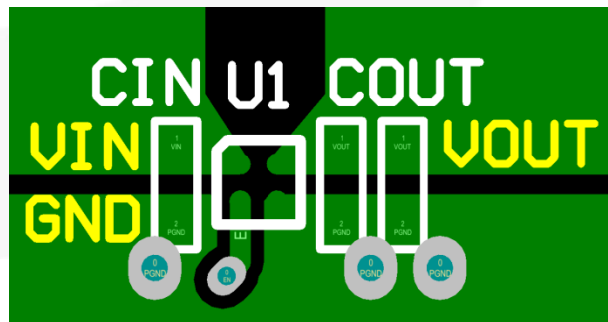
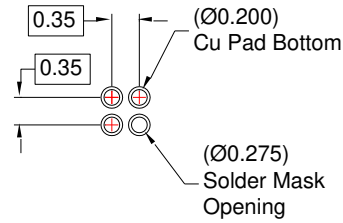
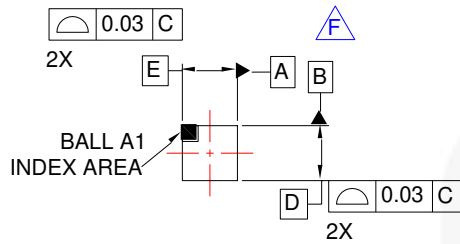

Figure 18. Recommended Layout

Physical Dimensions



TOP VIEW

RECOMMENDED LAND PATTERN (NSMD TYPE)

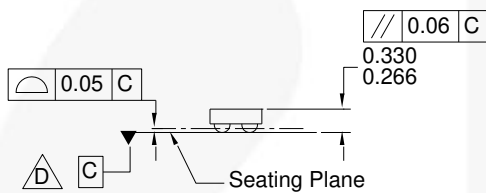

SIDE VIEWS

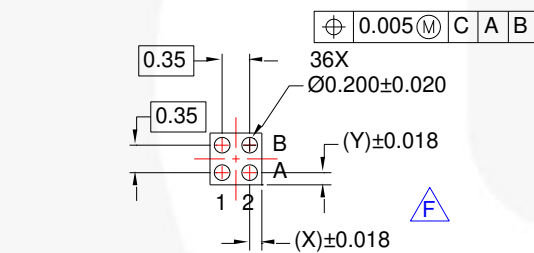
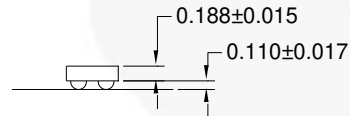

BOTTOM VIEW

NOTES

- A. NO JEDEC REGISTRATION APPLIES.
- B. DIMENSIONS ARE IN MILLIMETERS.
- C. DIMENSIONS AND TOLERANCE PER ASME Y14.5M, 2009.
- D. DATUM C IS DEFINED BY THE SPHERICAL CROWNS OF THE BALLS.
- E. PACKAGE NOMINAL HEIGHT IS 298 ± 32 MICRONS (266-330 MICRONS).
- F. FOR DIMENSIONS D, E, X, AND Y SEE PRODUCT DATASHEET.
- G. DRAWING FILNAME: MKT-UC004AK REV1

Figure 19. 4-Ball, Wafer-Level, Chip-Scale Package (WLCSP), 0.35 mm Pitch

Product-Specific Dimensions

D	E	X	Y
0.65 ±0.025 mm	0.65 ±0.025 mm	0.15 mm	0.15 mm

Package drawings are provided as a service to customers considering Fairchild components. Drawings may change in any manner without notice. Please note the revision and/or date on the drawing and contact a Fairchild Semiconductor representative to verify or obtain the most recent revision. Package specifications do not expand the terms of Fairchild's worldwide terms and conditions, specifically the warranty therein, which covers Fairchild products.

Always visit Fairchild Semiconductor's online packaging area for the most recent package drawings:
<http://www.fairchildsemi.com/dwg/UC/UC004AK.pdf>

For current packing container specifications, visit Fairchild Semiconductor's online packaging area:
http://www.fairchildsemi.com/packing_dwg/PKG-UC004AK.pdf



TRADEMARKS

The following includes registered and unregistered trademarks and service marks, owned by Fairchild Semiconductor and/or its global subsidiaries, and is not intended to be an exhaustive list of all such trademarks.

- | | | | |
|--------------------------------------|--|---------------------------------------|----------------------------|
| AccuPower™ | F-PFS™ | | |
| AX-CAP SM * | FRFET [®] | PowerTrench [®] | TinyBoost [®] |
| BitSiC™ | Global Power Resource SM | PowerXS™ | TinyBuck [®] |
| Build it Now™ | GreenBridge™ | Programmable Active Droop™ | TinyCalc™ |
| CorePLUS™ | Green FPS™ | QFET [®] | TinyLogic [®] |
| CorePOWER™ | Green FPS™ e-Series™ | QS™ | TINYOPTO™ |
| CROSSVOLT™ | Gmax™ | Quiet Series™ | TinyPower™ |
| CTL™ | GTO™ | RapidConfigure™ | TinyPVM™ |
| Current Transfer Logic™ | IntelliMAX™ | | TinyWire™ |
| DEUXPEED [®] | ISOPLANAR™ | Saving our world, 1mW/W/kW at a time™ | TranSiC™ |
| Dual Cool™ | Making Small Speakers Sound Louder and Better™ | SignalWise™ | TriFault Detect™ |
| EcoSPARK [®] | MegaBuck™ | SmartMax™ | TRUECURRENT [®] * |
| EfficientMax™ | MICROCOUPLER™ | SMART START™ | μSerDes™ |
| ESBC™ | MicroFET™ | Solutions for Your Success™ | |
| | MicroPak™ | SPM [®] | UHC [®] |
| Fairchild [®] | MicroPak2™ | STEALTH™ | Ultra FRFET™ |
| Fairchild Semiconductor [®] | MillerDrive™ | SuperFET [®] | UniFET™ |
| FACT Quiet Series™ | MotionMax™ | SuperSOT™-3 | VCX™ |
| FACT [®] | mWSaver [®] | SuperSOT™-6 | VisualMax™ |
| FAST [®] | OptoHiT™ | SuperSOT™-8 | VoltagePlus™ |
| FastvCore™ | OPTOLOGIC [®] | SupreMOS [®] | XS™ |
| FETBench™ | OPTOPLANAR [®] | SyncFET™ | 仙童™ |
| FPS™ | | Sync-Lock™ | |

* Trademarks of System General Corporation, used under license by Fairchild Semiconductor.

DISCLAIMER

FAIRCHILD SEMICONDUCTOR RESERVES THE RIGHT TO MAKE CHANGES WITHOUT FURTHER NOTICE TO ANY PRODUCTS HEREIN TO IMPROVE RELIABILITY, FUNCTION, OR DESIGN. FAIRCHILD DOES NOT ASSUME ANY LIABILITY ARISING OUT OF THE APPLICATION OR USE OF ANY PRODUCT OR CIRCUIT DESCRIBED HEREIN; NEITHER DOES IT CONVEY ANY LICENSE UNDER ITS PATENT RIGHTS, NOR THE RIGHTS OF OTHERS. THESE SPECIFICATIONS DO NOT EXPAND THE TERMS OF FAIRCHILD'S WORLDWIDE TERMS AND CONDITIONS, SPECIFICALLY THE WARRANTY THEREIN, WHICH COVERS THESE PRODUCTS.

LIFE SUPPORT POLICY

FAIRCHILD'S PRODUCTS ARE NOT AUTHORIZED FOR USE AS CRITICAL COMPONENTS IN LIFE SUPPORT DEVICES OR SYSTEMS WITHOUT THE EXPRESS WRITTEN APPROVAL OF FAIRCHILD SEMICONDUCTOR CORPORATION.

As used herein:

1. Life support devices or systems are devices or systems which, (a) are intended for surgical implant into the body or (b) support or sustain life, and (c) whose failure to perform when properly used in accordance with instructions for use provided in the labeling, can be reasonably expected to result in a significant injury of the user.
2. A critical component in any component of a life support, device, or system whose failure to perform can be reasonably expected to cause the failure of the life support device or system, or to affect its safety or effectiveness.

ANTI-COUNTERFEITING POLICY

Fairchild Semiconductor Corporation's Anti-Counterfeiting Policy. Fairchild's Anti-Counterfeiting Policy is also stated on our external website, www.fairchildsemi.com, under Sales Support.

Counterfeiting of semiconductor parts is a growing problem in the industry. All manufacturers of semiconductor products are experiencing counterfeiting of their parts. Customers who inadvertently purchase counterfeit parts experience many problems such as loss of brand reputation, substandard performance, failed applications, and increased cost of production and manufacturing delays. Fairchild is taking strong measures to protect ourselves and our customers from the proliferation of counterfeit parts. Fairchild strongly encourages customers to purchase Fairchild parts either directly from Fairchild or from Authorized Fairchild Distributors who are listed by country on our web page cited above. Products customers buy either from Fairchild directly or from Authorized Fairchild Distributors are genuine parts, have full traceability, meet Fairchild's quality standards for handling and storage and provide access to Fairchild's full range of up-to-date technical and product information. Fairchild and our Authorized Distributors will stand behind all warranties and will appropriately address any warranty issues that may arise. Fairchild will not provide any warranty coverage or other assistance for parts bought from Unauthorized Sources. Fairchild is committed to combat this global problem and encourage our customers to do their part in stopping this practice by buying direct or from authorized distributors.

PRODUCT STATUS DEFINITIONS

Definition of Terms

Datasheet Identification	Product Status	Definition
Advance Information	Formative / In Design	Datasheet contains the design specifications for product development. Specifications may change in any manner without notice.
Preliminary	First Production	Datasheet contains preliminary data; supplementary data will be published at a later date. Fairchild Semiconductor reserves the right to make changes at any time without notice to improve design.
No Identification Needed	Full Production	Datasheet contains final specifications. Fairchild Semiconductor reserves the right to make changes at any time without notice to improve the design.
Obsolete	Not In Production	Datasheet contains specifications on a product that is discontinued by Fairchild Semiconductor. The datasheet is for reference information only.

Rev. I68