

FSA859 — Dual-Voltage, 0.8Ω SPDT Analog Switch with Power-Off Isolation

Features

- Power-Off Isolation ($V_{CC}=0V$)
- 0.8Ω Maximum On Resistance (R_{ON}) for 4.5V V_{CC}
- 0.25Ω Maximum R_{ON} Flatness for 4.5V V_{CC}
- Broad V_{CC} Operating Range: 1.65V to 5.5V
- Fast Turn-On and Turn-Off Times
- Control Input Referenced to V_{IO}
- Break-Before-Make Enable Circuitry
- 0.5mm WLCSP packaging
- ESD Performance
 - HBM: JESD22-A114, I/O to GND 8kV
 - CDM: JESD22-C101 500V
 - IEC61000-4-2 Contact / Air 8kV / 15kV

Description

The FSA859 is a high-performance Single-Pole / Double-Throw (SPDT) analog switch for audio applications driven by low voltage (1.8V) baseband processors or ASICs. The device features ultra-low R_{ON} of 0.8Ω (maximum) at 4.5V V_{CC} and operates over the wide V_{CC} range of 1.65V to 5.5V. The device is fabricated with sub-micron CMOS technology to achieve fast switching speeds and is designed for break-before-make operation.

The FSA859 interfaces between the low-voltage ASIC and regular audio amplifiers and CODECs operating up to the supply range of 5.5V through the dual-voltage supplies of V_{IO} and V_{CC} . The V_{IO} supply operates the control circuitry, allowing for 1.8V (typical) signals on the control pin (Sel).

Applications

- Cellular Phone
- Portable Media Player
- PDA

IMPORTANT NOTE:

For additional performance information, please contact analogswitch@fairchildsemi.com.

Ordering Information

Part Number	Operating Temperature Range	Top Mark	Eco Status	Package	Packing Method
FSA859UCX	-40°C to +85°C	N2	Green	8-Ball WLCSP, 0.5mm pitch	Tape and Reel

For Fairchild's definition of "green" Eco Status, please visit: http://www.fairchildsemi.com/company/green/rohs_green.html.

Analog Symbols

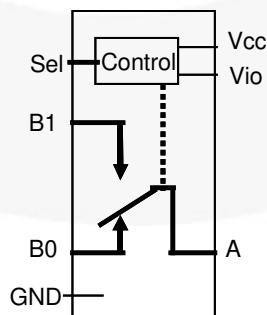
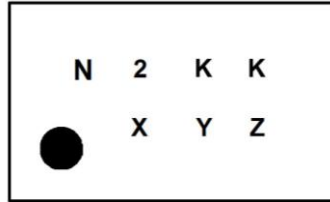

Figure 1. Analog Symbol

Marking Information



KK = Lot Run Code
 X = Year
 Y = Work Week
 Z = Assembly Site

Figure 2. Top Mark with Pin 1 Orientation

Pin Configuration

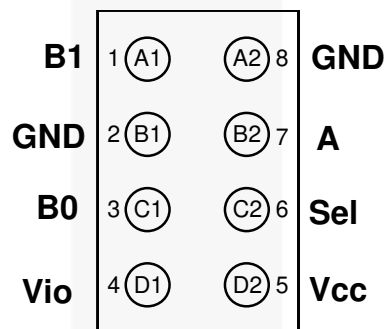

Figure 3. Pin Assignments (Top Through View)

Pin Definitions

Pin	Ball	Name	Description
1	A1	B1	Data Port (Normally Open)
2	B1	GND	Ground
3	C1	B0	Data Ports (Normally Closed)
4	D1	V _{IO}	Digital Control Supply
5	D2	V _{CC}	Supply Voltage
6	C2	Sel	Control Input
7	B2	A	Common Data Port
8	A2	GND	Ground

Truth Table

Control Input (Sel)	Function
LOW	B0 connected to A
HIGH	B1 connected to A

Absolute Maximum Ratings

Stresses exceeding the absolute maximum ratings may damage the device. The device may not function or be operable above the recommended operating conditions and stressing the parts to these levels is not recommended. In addition, extended exposure to stresses above the recommended operating conditions may affect device reliability. The absolute maximum ratings are stress ratings only.

Symbol	Parameter		Min.	Max.	Unit
V_{CC}	Supply Voltage		-0.5	6.5	V
V_{IO}	Digital Control Supply Voltage		-0.5	6.5	V
V_{SW}	Switch Voltage ⁽¹⁾		-0.5	$V_{CC} + 0.5$	V
V_{IN}	Input Voltage ⁽¹⁾		-0.5	6.5	V
I_{IK}	Input Diode Current			-50	mA
I_{SW}	Switch Current (Continuous)			200	mA
I_{SWPEAK}	Peak Switch Current	Pulsed at 1ms Duration, <10% Duty Cycle		400	mA
P_D	Power Dissipation at 85°C			180	mW
T_{STG}	Storage Temperature Range		-65	+150	°C
T_J	Maximum Junction Temperature			+150	°C
T_L	Lead Temperature (Soldering, 10 seconds)			+260	°C
ESD	Human Body Model (JEDEC: JESD22-A114)	I/O to GND: A		8	kV
		All Pins		2	
	Charged Device Model (JEDEC: JESD22-C101)			500	V
	Machine Model (JEDEC: JESD22-A115)			100	V
	IEC6100-4-2 Discharge system test performed on Fairchild's FSA859 applications testing board	Contact		8	kV
Air			15		

Note:

- The input and output negative ratings may be exceeded if the input and output diode current ratings are observed.

Recommended Operating Conditions

The Recommended Operating Conditions table defines the conditions for actual device operation. Recommended operating conditions are specified to ensure optimal performance to the datasheet specifications. Fairchild does not recommend exceeding them or designing to Absolute Maximum Ratings.

Symbol	Parameter	Min.	Max.	Unit
V_{CC}	Supply Voltage	1.65	5.50	V
V_{IO}	Digital Control Supply	1.65	1.95	V
Sel	Control Input Voltage ⁽²⁾	0	V_{IO}	V
V_{SW}	Switch Input Voltage	0	V_{CC}	V
T_A	Operating Temperature	-40	+85	°C
θ_{JA}	Thermal Resistance, Still Air		350	°C/W

Note:

- Control Input must be held HIGH or LOW; it must not float.

Electrical Characteristics

All typical values are at 25°C unless otherwise specified. $V_{IO}=1.65$ to $1.95V$.

Symbol	Parameter	V_{CC} (V)	Conditions	$T_A=+25^\circ C$			$T_A=-40$ to $+85^\circ C$		Unit
				Min.	Typ.	Max.	Min.	Max.	
V_{IHIO}	Input Voltage High - V_{IO}	1.95 to 5.50					$0.65 \cdot V_{IO}$	V_{IO}	V
V_{ILIO}	Input Voltage Low - V_{IO}	1.95 to 5.50					0	$0.35 \cdot V_{IO}$	V
I_{IN}	Control Input Leakage	1.95 to 5.50	$V_{SEL}=0$ or V_{IO}	-2		2	-20	20	nA
$I_{NO(OFF)}$, $I_{NC(OFF)}$	Off-Leakage Current of Port B0 and B1 ⁽⁶⁾	5.50	A=1V, 4.5V B0 or B1=4.5, 1V	-10		10	-50	50	nA
		3.60	A=1V, 3.0V B0 or B1=3.0, 1V	-10		10	-50	50	
		2.70	A=0.5V, 2.3V B0 or B1=2.3, 0.5V	-10		10	-50	50	
		1.95	A=0.3V, 1.65V B0 or B1=1.65, 0.3 V	-5		5	-20	20	
$I_{NO(ON)}$, $I_{NC(ON)}$	On-Leakage Current of Port B0 and B1 ⁽⁶⁾	5.50	A=float B0 or B1=4.5, 1V	-20		20	-100	100	nA
		3.60	A=float B0 or B1=3.0, 1V	-10		10	-20	20	
		2.70	A=float B0 or B1=2.3, 0.5V	-10		10	-20	20	
		1.95	A=float B0 or B1=1.65, 0.3V	-5		5	-20	20	
$I_{A(ON)}$	On Leakage Current of Port A ⁽⁶⁾	5.50	A=1V, 4.5V; B0 or B1=1V, 4.5V or floating	-20		20	-100	100	nA
		3.60	A=1V, 3.0V B0 or B1=1V, 3.0V or floating	-10		10	-20	20	
		2.70	A=0.5V, 2.3V, B0 or B1=0.5V, 2.3V, or floating	-10		10	-20	20	
		1.95	A=0.3V, 1.65V; B0 or B1=0.3V, 1.65V, or floating	-5		5	-20	20	
I_{OFF}	Power Off Leakage Current of Port A & Port B ⁽⁶⁾	0	A=0 to 5.5V B0 or B1=0 to 5.5V	-1.00	0.01	1.00	-5.00	5.00	μA
I_{CC}	Quiescent Supply Current	5.50	$V_{IN}=0$ or V_{CC} , $I_{OUT}=0$		10	50		500	nA
		3.60	$V_{IN}=0$ or V_{CC} , $I_{OUT}=0$		1.0	25.0		100.0	
		2.70	$V_{IN}=0$ or V_{CC} , $I_{OUT}=0$		0.5	20.0		50.0	
		1.95	$V_{IN}=0$ or V_{CC} , $I_{OUT}=0$		0.5	15.0		50.0	

Continued on the following page...

Electrical Characteristics (Continued)

All typical values are at 25°C unless otherwise specified. $V_{IO}=1.65$ to $1.95V$.

Symbol	Parameter	V_{CC} (V)	Conditions	$T_A=+25^\circ C$			$T_A=-40$ to $+85^\circ C$		Unit
				Min.	Typ.	Max.	Min.	Max.	
R_{ON}	Switch On Resistance ^(3,6)	4.50	$I_{OUT}=-100mA$, B0 or B1=2.5V		0.50	0.75		0.80	Ω
		3.00	$I_{OUT}=-100mA$, B0 or B1=2.0V		0.75	0.90		1.2	
		2.25	$I_{OUT}=-100mA$, B0 or B1=1.8V		1.0	1.3		1.6	
		1.65	$I_{OUT}=-100mA$, B0 or B1=1.2V		2.5	5.0		7.0	
ΔR_{ON}	On Resistance Matching Between Channels ^(4,6)	4.50	$I_{OUT}=-100mA$, B0 or B1=2.5V		0.05	0.10		0.10	Ω
		3.00	$I_{OUT}=-100mA$, B0 or B1=2.0V		0.10	0.15		0.15	
		2.25	$I_{OUT}=-100mA$, B0 or B1=1.8V		0.15	0.20		0.20	
		1.65	$I_{OUT}=-100mA$, B0 or B1=1.2V		0.15	0.40		0.40	
$R_{FLAT(ON)}$	On Resistance Flatness ^(5,6)	4.50	$I_{OUT}=-100mA$, B0 or B1=1.0V, 1.5V, 2.5V		0.075	0.250		0.250	Ω
		3.00	$I_{OUT}=-100mA$, B0 or B1=0.8V, 2.0V		0.1	0.3		0.3	
		2.25	$I_{OUT}=-100mA$, B0 or B1=0.8V, 1.8V		0.25	0.50		0.6	
		1.65	$I_{OUT}=-100mA$, B0 or B1=0.6V, 1.2V		3.5				

Notes:

3. On resistance is determined by the voltage drop between A and B pins at the indicated current through the switch.
4. $\Delta R_{ON}=R_{ON}$ maximum – R_{ON} minimum measured at identical V_{CC} , temperature, and voltage.
5. Flatness is defined as the difference between the maximum and minimum value of on resistance over the specified range of conditions.
6. Guaranteed by characterization, not production tested for $V_{CC}=1.65 - 1.95V$.

AC Electrical Characteristics

All typical value are at $V_{IO}=1.8V$ and $V_{CC}=1.8V, 2.5V, 3.0V,$ and $5.0V$ at $25^{\circ}C$ unless otherwise specified.

Symbol	Parameter	V_{CC} (V)	Conditions	$T_A=+25^{\circ}C$			$T_A=-40$ to $+85^{\circ}C$		Unit	Figure
				Min.	Typ.	Max.	Min.	Max.		
t_{ON}	Turn-On Time ⁽⁶⁾	4.50 to 5.50	$B0$ or $B1=V_{CC},$ $R_L=50\Omega,$ $C_L=35pF$	1.0	12.0	25.0	1.0	30.0	ns	Figure 4
		3.00 to 3.60		5.0	15.0	30.0	3.0	35.0		
		2.30 to 2.70		5.0	20.0	35.0	5.0	40.0		
		1.65 to 1.95		10.0	50.0	70.0	10.0	75.0		
t_{OFF}	Turn-Off Time ⁽⁶⁾	4.50 to 5.50	$B0$ or $B1=V_{CC},$ $R_L=50\Omega,$ $C_L=35pF$	1.0	9.5	20.0	1.0	25.0	ns	Figure 4
		3.00 to 3.60		1.0	9.0	20.0	1.0	25.0		
		2.30 to 2.70		2.0	10.0	20.0	2.0	25.0		
		1.65 to 1.95		2.0	28.0	40.0	2.0	50.0		
t_{BBM}	Break-Before-Make Time ⁽⁶⁾	4.50 to 5.50	$B0$ or $B1=V_{CC},$ $R_L=50\Omega,$ $C_L=35pF$	1.0	10.0	12.0	0.1	14.0	ns	Figure 5
		3.00 to 3.60		1.0	14.0	16.0	1.0	17.0		
		2.30 to 2.70		1.0	21.0	25.0	1.0	27.0		
		1.65 to 1.95			35.0		2.0	50.0		
Q	Charge Injection	5.50	$C_L=1.0nF,$ $V_{GEN}=0V,$ $R_{GEN}=0\Omega$		47				pC	Figure 7
		3.30			33					
		2.50			23					
		1.65			10					
OIRR	Off Isolation	1.8 to 5.0	$f=1MHz, R_L=50\Omega$		-60				dB	Figure 6
Xtalk	Crosstalk	1.8 to 5.0	$f=1MHz, R_L=50\Omega$		55				dB	Figure 6
BW	-3db Bandwidth	5.50	$R_L=50\Omega$		60				MHz	Figure 9
		3.30			60					
		2.50			55					
		1.65			50					
THD	Total Harmonic Distortion	1.80	$R_L=600\Omega,$ $V_{IN}=0.5V_{PP},$ $f=20Hz$ to $20kHz$.015				%	Figure 10
		5.00			.002					

Capacitance

Symbol	Parameter	V_{CC} (V)	Conditions	$T_A=+25^{\circ}C$			Unit
				Min.	Typ.	Max.	
C_{IN}	Control Pin Input Capacitance	0	$f=1MHz$		3.2		pF
C_{OFF}	B Port Off Capacitance	1.65 to 5.50	$f=1MHz$		50		pF
C_{ON}	A Port On Capacitance	1.65 to 5.50	$f=1MHz$		150		pF

Test Diagrams

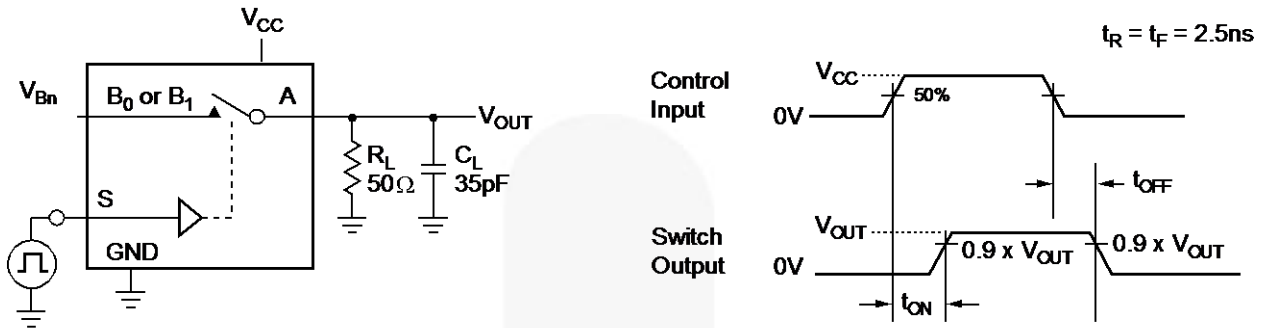

C_L includes fixture and stray capacitance.

Logic input waveforms inverted for switches that have the opposite logic sense.

Figure 4. Turn On / Off Timing

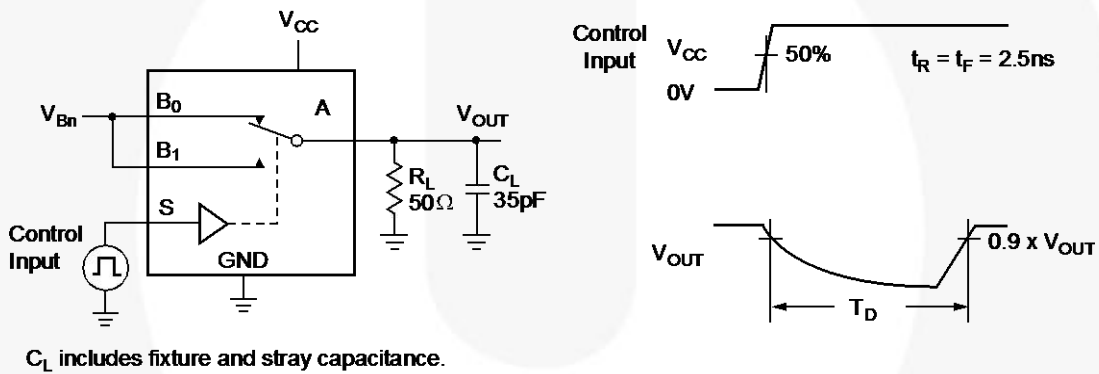

C_L includes fixture and stray capacitance.

Figure 5. Break-Before-Make Timing

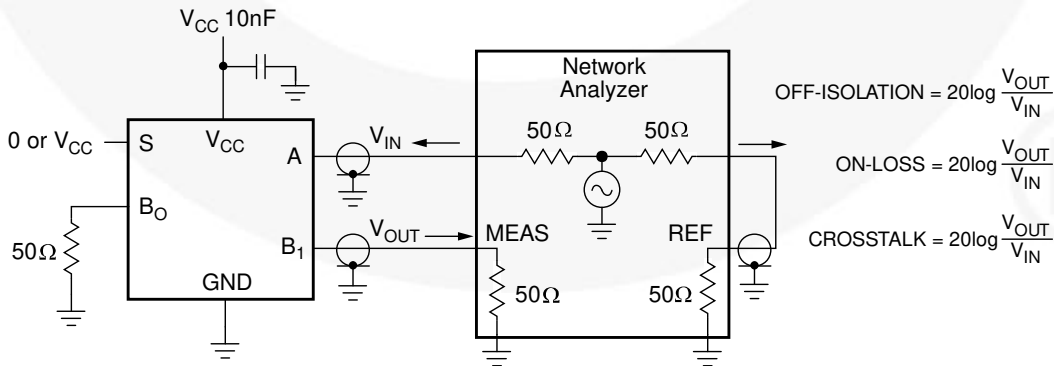

Figure 6. Off Isolation and Crosstalk

Test Diagrams (Continued)

Figure 7. Charge Injection

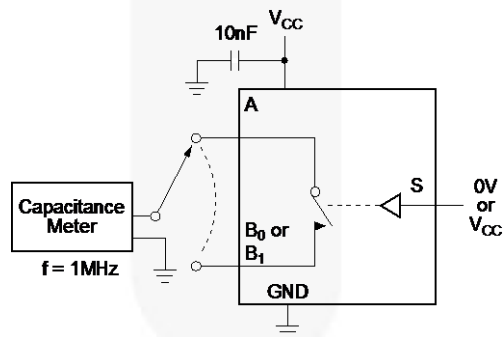

Figure 8. On / Off Capacitance Measurement Setup

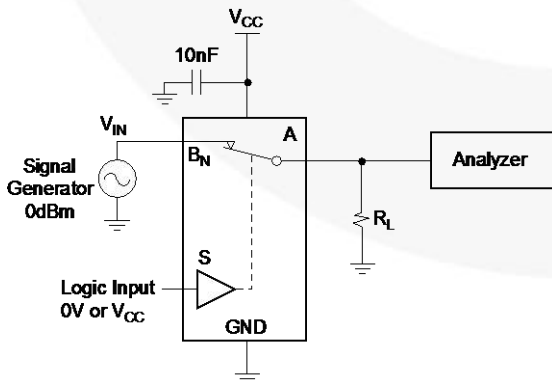

Figure 9. Bandwidth

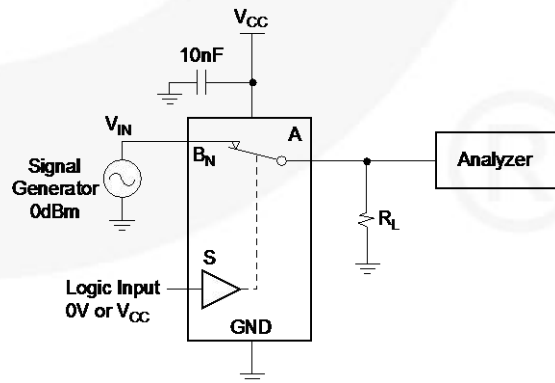

Figure 10. Harmonic Distortion

Physical Dimensions

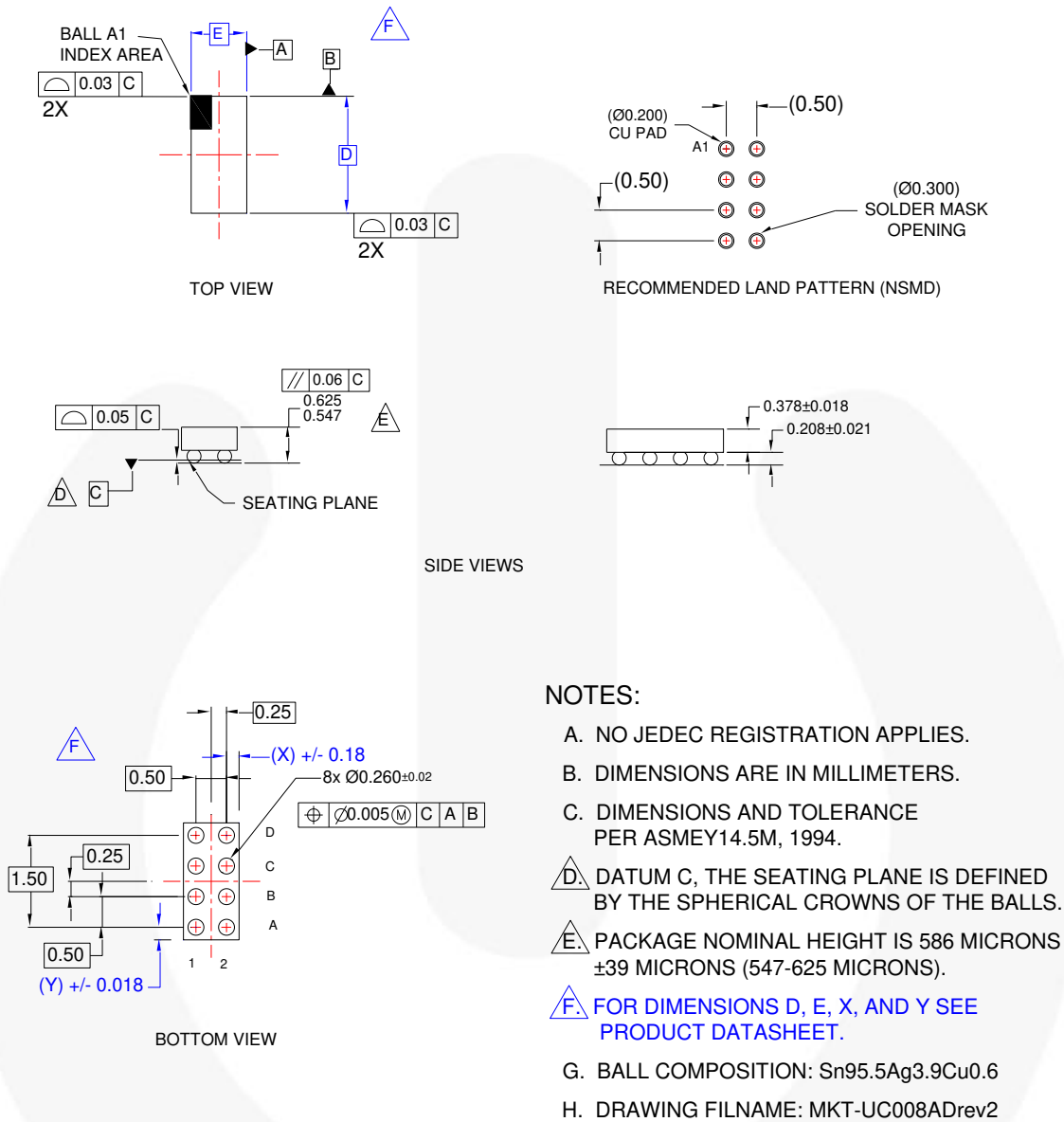

Figure 11. 8-Ball, WLCSP 0.5mm Pitch

Table 1. Product Specific Dimensions

Product	D	E	X	Y
FSA859UCX	1.910	0.910	0.205	0.205

Package drawings are provided as a service to customers considering Fairchild components. Drawings may change in any manner without notice. Please note the revision and/or date on the drawing and contact a Fairchild Semiconductor representative to verify or obtain the most recent revision. Package specifications do not expand the terms of Fairchild's worldwide terms and conditions, specifically the warranty therein, which covers Fairchild products.

Always visit Fairchild Semiconductor's online packaging area for the most recent package drawings:
<http://www.fairchildsemi.com/packaging/>



TRADEMARKS

The following includes registered and unregistered trademarks and service marks, owned by Fairchild Semiconductor and/or its global subsidiaries, and is not intended to be an exhaustive list of all such trademarks.

- | | | | |
|---|--------------------------|---|---|
| Build it Now™ | FPST™ | PDP SPM™ | The Power Franchise® |
| CorePLUS™ | F-PFST™ | Power-SPM™ | the power franchise |
| CorePOWER™ | FRFET® | PowerTrench® | TinyBoost™ |
| CROSSVOLT™ | Global Power Resource SM | Programmable Active Droop™ | TinyBuck™ |
| CTL™ | Green FPST™ | QFET® | TinyLogic® |
| Current Transfer Logic™ | Green FPST™ e-Series™ | QST™ | TINYOPTO™ |
| EcoSPARK® | GTO™ | Quiet Series™ | TinyPower™ |
| EfficientMax™ | IntelliMAX™ | RapidConfigure™ | TinyPWM™ |
| EZSWITCH™ * | ISOPLANAR™ | Saving our world, 1mW at a time™ | TinyWire™ |
|  ™ | MegaBuck™ | SmartMax™ | μSerDes™ |
|  ® | MICROCOUPLER™ | SMART START™ |  |
| Fairchild® | MicroFET™ | SPM® | UHC® |
| Fairchild Semiconductor® | MicroPak™ | STEALTH™ | Ultra FRFET™ |
| FACT Quiet Series™ | MillerDrive™ | SuperFET™ | UniFET™ |
| FACT® | MotionMax™ | SuperSOT™.3 | VCX™ |
| FAST® | Motion-SPM™ | SuperSOT™.6 | VisualMax™ |
| FastvCore™ | OPTOLOGIC® | SuperSOT™.8 | |
| FlashWriter® * | OPTOPLANAR® | SupreMOS™ | |
| | | SyncFET™ | |
| | |  | |

* EZSWITCH™ and FlashWriter® are trademarks of System General Corporation, used under license by Fairchild Semiconductor.

DISCLAIMER

FAIRCHILD SEMICONDUCTOR RESERVES THE RIGHT TO MAKE CHANGES WITHOUT FURTHER NOTICE TO ANY PRODUCTS HEREIN TO IMPROVE RELIABILITY, FUNCTION, OR DESIGN. FAIRCHILD DOES NOT ASSUME ANY LIABILITY ARISING OUT OF THE APPLICATION OR USE OF ANY PRODUCT OR CIRCUIT DESCRIBED HEREIN; NEITHER DOES IT CONVEY ANY LICENSE UNDER ITS PATENT RIGHTS, NOR THE RIGHTS OF OTHERS. THESE SPECIFICATIONS DO NOT EXPAND THE TERMS OF FAIRCHILD'S WORLDWIDE TERMS AND CONDITIONS, SPECIFICALLY THE WARRANTY THEREIN, WHICH COVERS THESE PRODUCTS.

LIFE SUPPORT POLICY

FAIRCHILD'S PRODUCTS ARE NOT AUTHORIZED FOR USE AS CRITICAL COMPONENTS IN LIFE SUPPORT DEVICES OR SYSTEMS WITHOUT THE EXPRESS WRITTEN APPROVAL OF FAIRCHILD SEMICONDUCTOR CORPORATION.

As used herein:

1. Life support devices or systems are devices or systems which, (a) are intended for surgical implant into the body or (b) support or sustain life, and (c) whose failure to perform when properly used in accordance with instructions for use provided in the labeling, can be reasonably expected to result in a significant injury of the user.
2. A critical component in any component of a life support, device, or system whose failure to perform can be reasonably expected to cause the failure of the life support device or system, or to affect its safety or effectiveness.

ANTI-COUNTERFEITING POLICY

Fairchild Semiconductor Corporation's Anti-Counterfeiting Policy. Fairchild's Anti-Counterfeiting Policy is also stated on our external website, www.fairchildsemi.com, under Sales Support.

Counterfeiting of semiconductor parts is a growing problem in the industry. All manufacturers of semiconductor products are experiencing counterfeiting of their parts. Customers who inadvertently purchase counterfeit parts experience many problems such as loss of brand reputation, substandard performance, failed applications, and increased cost of production and manufacturing delays. Fairchild is taking strong measures to protect ourselves and our customers from the proliferation of counterfeit parts. Fairchild strongly encourages customers to purchase Fairchild parts either directly from Fairchild or from Authorized Fairchild Distributors who are listed by country on our web page cited above. Products customers buy either from Fairchild directly or from Authorized Fairchild Distributors are genuine parts, have full traceability, meet Fairchild's quality standards for handling and storage and provide access to Fairchild's full range of up-to-date technical and product information. Fairchild and our Authorized Distributors will stand behind all warranties and will appropriately address any warranty issues that may arise. Fairchild will not provide any warranty coverage or other assistance for parts bought from Unauthorized Sources. Fairchild is committed to combat this global problem and encourage our customers to do their part in stopping this practice by buying direct or from authorized distributors.

PRODUCT STATUS DEFINITIONS

Definition of Terms

Datasheet Identification	Product Status	Definition
Advance Information	Formative / In Design	Datasheet contains the design specifications for product development. Specifications may change in any manner without notice.
Preliminary	First Production	Datasheet contains preliminary data; supplementary data will be published at a later date. Fairchild Semiconductor reserves the right to make changes at any time without notice to improve design.
No Identification Needed	Full Production	Datasheet contains final specifications. Fairchild Semiconductor reserves the right to make changes at any time without notice to improve the design.
Obsolete	Not In Production	Datasheet contains specifications on a product that is discontinued by Fairchild Semiconductor. The datasheet is for reference information only.

Rev. 135