

CUSTOMER DRAWING

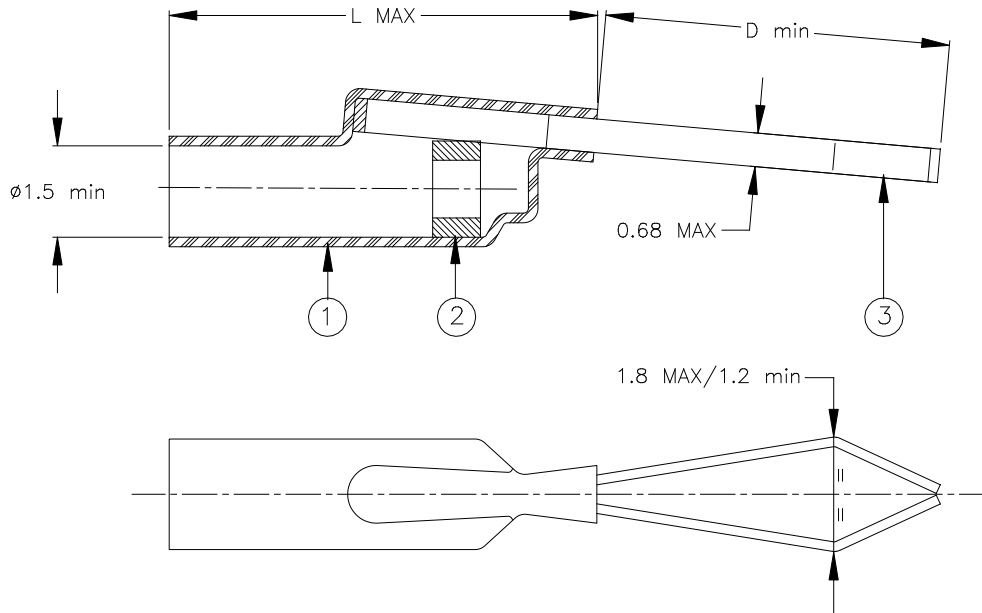

Product Name	AWG	D min	PCB Thickness min	PCB Thickness max	L max
B-801-10	20/28	7	3.15	5.60	11.4
B-801-11	20/28	5	1.20	3.15	13.4

MATERIAL

- INSULATION SLEEVE: Heat-shrinkable, radiation cross-linked modified polyvinylidene fluoride. Transparent blue.
- SOLDER PREFORM WITH FLUX:
SOLDER: TYPE Sn62 Pb36 Ag2 per ANSI J-STD-006.
FLUX: TYPE ROL0 per ANSI J-STD-004.
- PIN: Phosphor bronze coated with Sn60 Pb40 solder alloy.

APPLICATION

- These controlled soldering devices are designed to stay in position prior to soldering and to facilitate the strain-relieved termination of stranded wire to printed circuit boards with 1mm diameter holes. They will terminate the tin or silver plated copper conductor having an insulation rated for at least +125°C. Pre-tinning is required.
- Temperature range: -55°C to +150°C.

For best results, prepare the wire as shown:

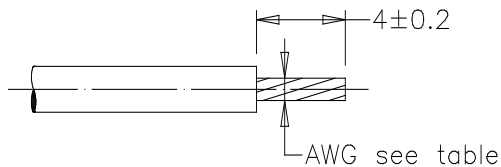

		Raychem THERMOFIT DEVICES		TITLE: PINPAK* DEVICE PCB TERMINATION	
Unless otherwise specified dimensions are in millimeters.				DOCUMENT NO.: B-801-10/-11	
TOLERANCES: 0.00 N/A 0.0 N/A 0 N/A	ANGLES: N/A ROUGHNESS IN MICRON	TE Connectivity reserves the right to amend this drawing at any time. Users should evaluate the suitability of the product for their application.		REV: 4	DATE: 09-Mar-2020
DRAWN BY: M. FORONDA	DATE: 22-Mar-1999	ECO: ECO-20-003687	SCALE: NTS	SIZE: A	SHEET: 1 of 1

© 09-Mar-2020 Tyco Electronics Corporation. All rights reserved.

If this document is printed it becomes uncontrolled. Check for the latest revision.

*TE Connectivity, TE connectivity (logo), Raychem, THERMOFIT, SolderSleeve are trademarks