

# DEVELOPMENT BOARD

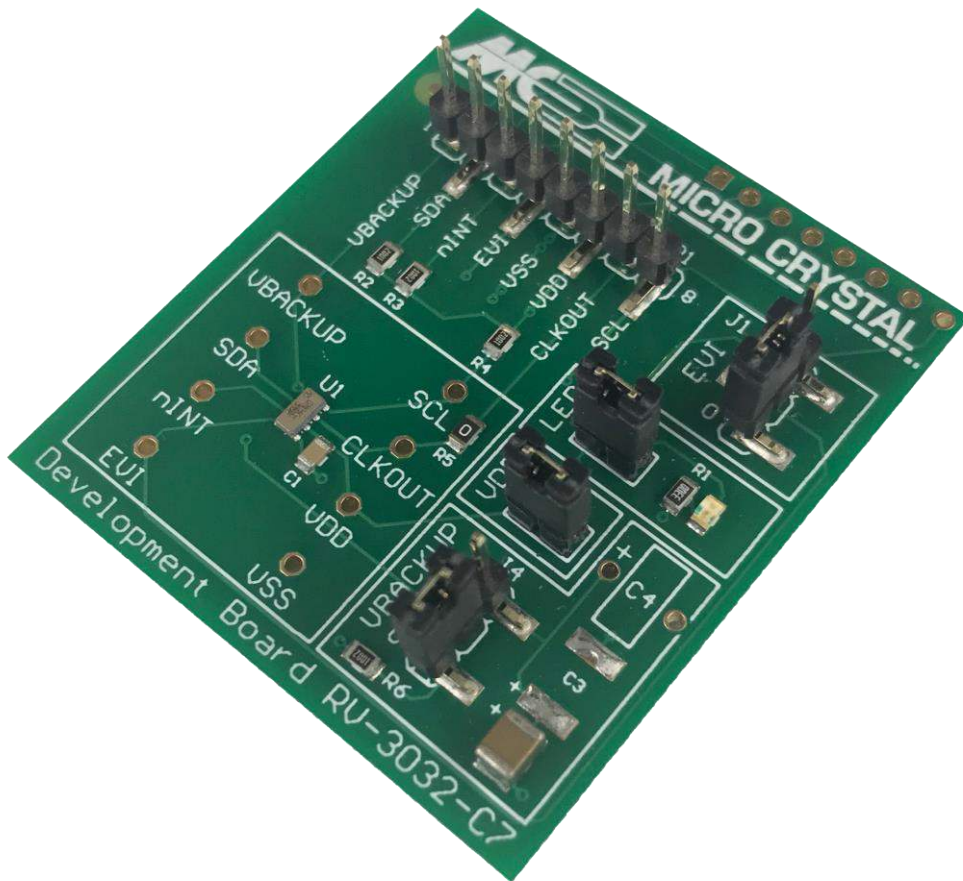

# TS-3032-C7

## Temperature Sensor & RTC Module

**PURPOSE:**

The development board RV-3032-C7 is used to test the part numbers listed here below:

- RV-3032-C7 TA QC
- RV-3032-C7 TA QA
- TS-3032-C7 TA QC
- TS-3032-C7 TA QA

**PINOUT TS-3032-C7**

		<table border="1"> <tr> <td># 1</td> <td>V<sub>BACKUP</sub></td> <td># 8</td> <td>SCL</td> </tr> <tr> <td># 2</td> <td>SDA</td> <td># 7</td> <td>CLKOUT</td> </tr> <tr> <td># 3</td> <td><math>\overline{\text{INT}}</math></td> <td># 6</td> <td>V<sub>DD</sub></td> </tr> <tr> <td># 4</td> <td>EVI</td> <td># 5</td> <td>V<sub>SS</sub></td> </tr> </table>		# 1	V <sub>BACKUP</sub>	# 8	SCL	# 2	SDA	# 7	CLKOUT	# 3	$\overline{\text{INT}}$	# 6	V <sub>DD</sub>	# 4	EVI	# 5	V <sub>SS</sub>
# 1	V <sub>BACKUP</sub>	# 8	SCL																
# 2	SDA	# 7	CLKOUT																
# 3	$\overline{\text{INT}}$	# 6	V <sub>DD</sub>																
# 4	EVI	# 5	V <sub>SS</sub>																

**PIN DESCRIPTION**

Symbol	Pin #	Description
V <sub>backup</sub>	1	Backup Supply Voltage. When the backup switchover function is not needed, V <sub>BACKUP</sub> must be tied to V <sub>SS</sub> with a 10 kΩ resistor.
SDA	2	I <sup>2</sup> C Serial Data Input-Output; open-drain; requires pull-up resistor. In VBACKUP Power state, the SDA pin is disabled (high impedance).
$\overline{\text{INT}}$	3	Interrupt Output; open-drain; active LOW; requires pull-up resistor; used to output Periodic Countdown Timer, Periodic Time Update, Alarm, Temperature Low, Temperature High, External Event, Voltage Low, Automatic Backup Switchover and Power On Reset Interrupt signals. Interrupt output also in VBACKUP Power state.
EVI	4	External Event Input; used for interrupt generation, interrupt driven clock output and time stamp function. Remains active also in VBACKUP Power state. This pin should not be left floating.
V <sub>SS</sub>	5	Ground
V <sub>DD</sub>	6	Backup Supply Voltage. When the backup switchover function is not needed, V <sub>BACKUP</sub> must be tied to V <sub>SS</sub> with a 10 kΩ resistor
CLKOUT	7	<p>Clock Output; push-pull; Normal and Interrupt driven clock output can be activated concurrently.</p> <ol style="list-style-type: none"> <li>1. Normal clock output is controlled by the NCLKE bit (EEPROM C0h). When NCLKE is set to 0 (default), the CLKOUT pin drives the square wave on the CLKOUT pin. When NCLKE bit is set to 1, the CLKOUT pin is LOW, if not enabled by the interrupt driven clock output.</li> <li>2. Interrupt driven clock output is controlled by an interrupt event. When CLKIE bit (11h) is set to 1 the occurrence of the interrupt selected in the Clock Interrupt Mask Register (14h) allows the square wave output on the CLKOUT pin [CLKOUT wake up for MCU]. Writing 0 to CLKIE will disable new interrupts from driving square wave on CLKOUT. When CLKF flag is cleared, the CLKOUT pin is LOW.</li> </ol> <ul style="list-style-type: none"> <li>• An Interrupt Delay after CLKOUT on can be enabled with bit INTDE (14h). [CLKOUT wake up for MCU]</li> <li>• A CLKOUT switch off delay after I<sup>2</sup>C STOP can be selected and enabled by bits CLKD and CLKDE (registers 14h and 15h). [Sleep mode command from MCU] (Delay not possible if CLKOUT was switched on normally) (MCU can go into sleep mode without a valid interrupt function being activated !!!)</li> </ul> <p>When OS bit is set to 0 (EEPROM C3h) and depending of the settings in the FD field (EEPROM C3h) the CLKOUT pin can drive the square wave of 32.768 kHz, 1024 Hz, 64 Hz or 1 Hz. When OS bit is set to 1 (EEPROM C3h) and depending on the settings in the HFD field (EEPROM C2h and C3h) the CLKOUT pin can drive the square wave of a frequency between 8192 Hz to 67.109 MHz in 8192 Hz steps. In VBACKUP Power state, the CLKOUT pin is LOW.</p>
SCL	8	I <sup>2</sup> C Serial Clock Input; requires pull-up resistor. In VBACKUP Power state, the SCL pin is disabled.

Datasheet and Application-Manual are available for download under:

<https://www.microcrystal.com/en/products/temperature-sensor-module/ts-3032-c7>

# TS-3032-C7

The TS-3032-C7 is soldered onto the Development Board.  
 Every pin is accessible at test pins 1 – 8 and at the test vias situated around the device.  
 The eight top-right vias (one-one copy of the test pins 1 – 8) can be used for angled connector.

The following passive components are already soldered on the board:

- C1 10 nF Decoupling capacitor between V<sub>SS</sub> and V<sub>DD</sub>
- C2 100uF Capacitor for Back-up power
- C3, C4 Option, to place alternative (super)-capacitors or battery/Ceracharge for back-up power
- R1 330 Ω Current limiting resistor for LED
- LED1 green Supply, current consumption of the LED has to be considered, J2 to switch off
- R2 10 kΩ Pull-up resistor SDA to V<sub>DD</sub>
- R3 10 kΩ Pull-up resistor INT to V<sub>DD</sub>
- R4 10 kΩ Pull-up resistor SCL to V<sub>DD</sub>
- R5 0 Ω Resistor to be unsoldered in case of high frequency signal issue
- R6 10 kΩ Pull-down resistor to define V<sub>BACKUP</sub> input in case it is not used

## DEVELOPMENT BOARD

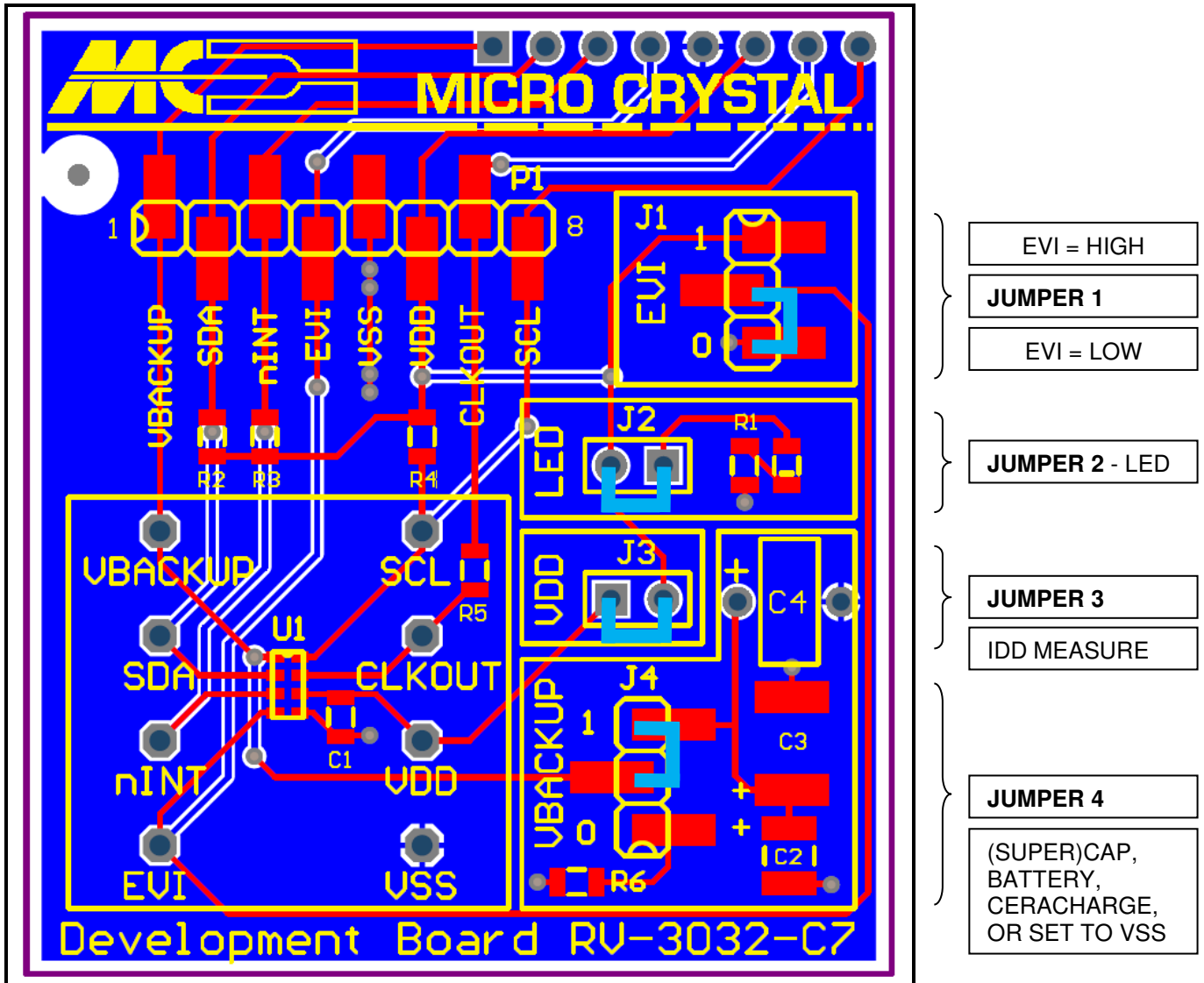

SCHEMATICS

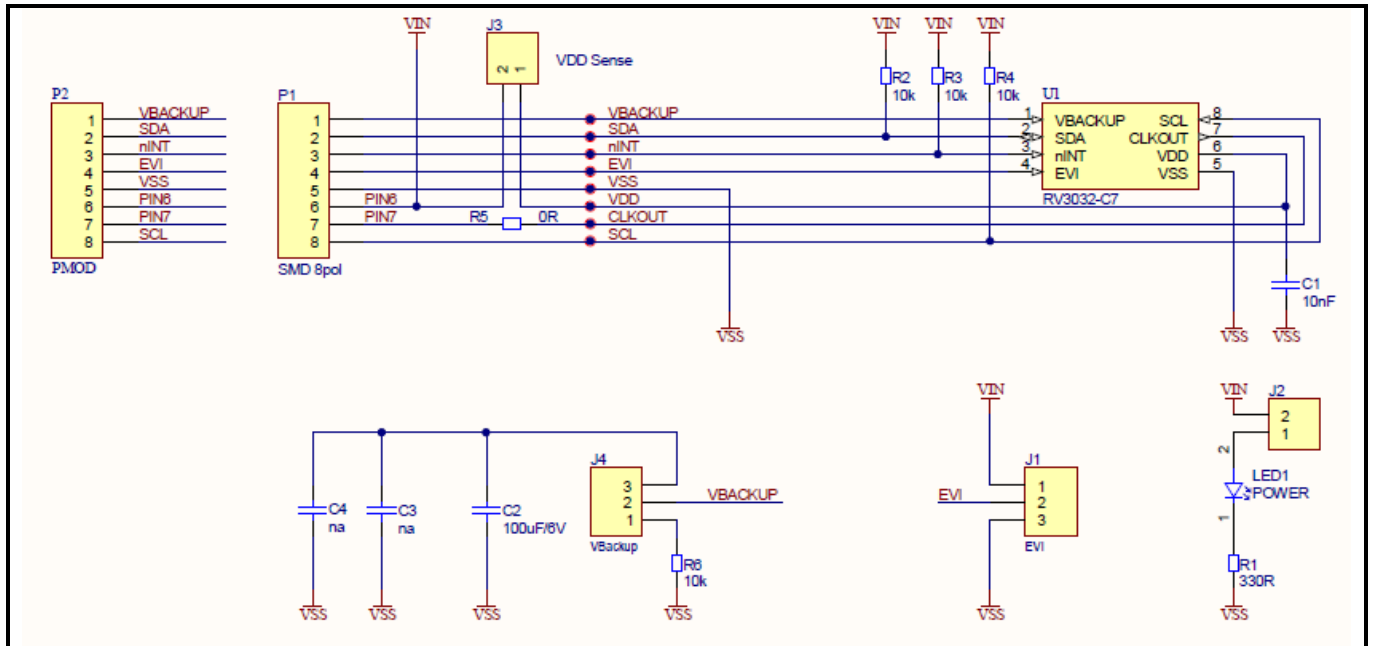

Datasheet and Application-Manual are available for download under:  
<https://www.microcrystal.com/en/products/temperature-sensor-module/ts-3032-c7>