

LOC	DIST	REVISIONS					
		P	LTN	DESCRIPTION	DATE	OWN	APVD
AD	00	A		INITIAL REVISION	13MAR2013	-	-

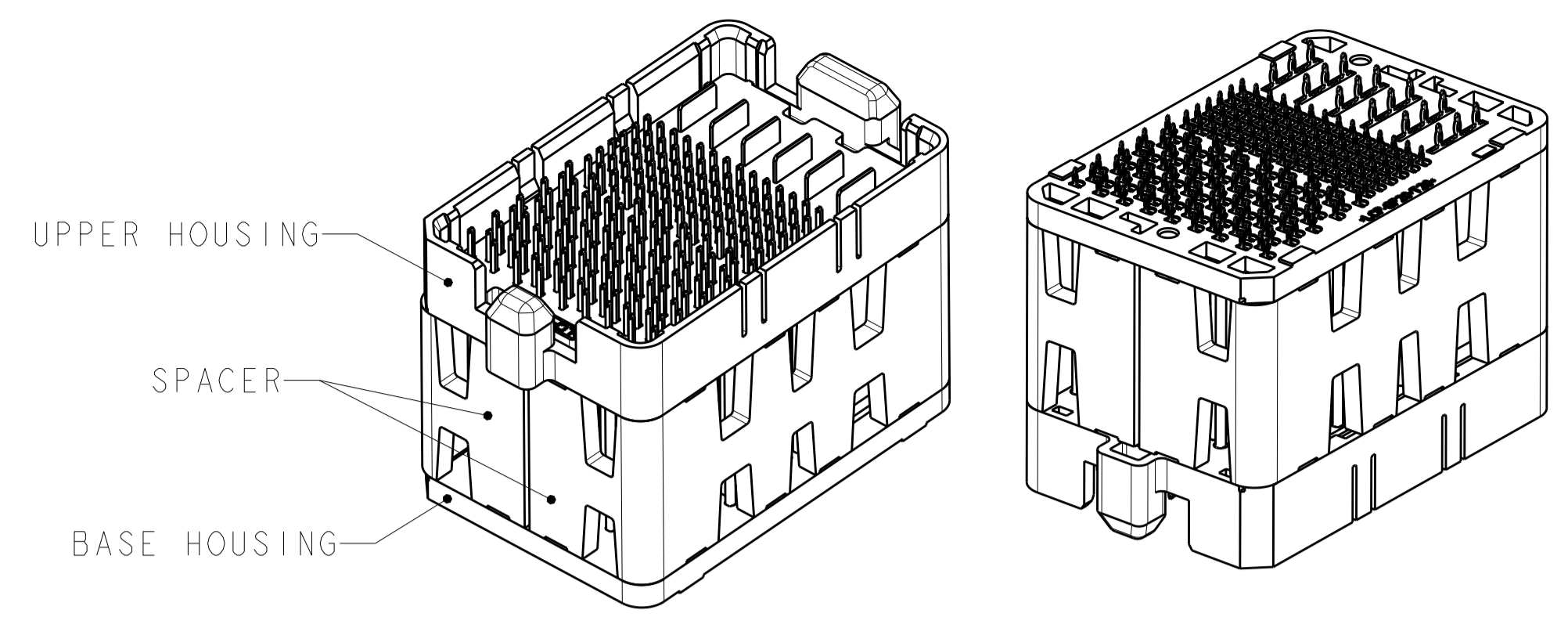

ISOMETRIC VIEW
TYPICAL CONFIGURATION FOR 14mm THRU 42mm
28mm SHOWN
SCALE 2:1

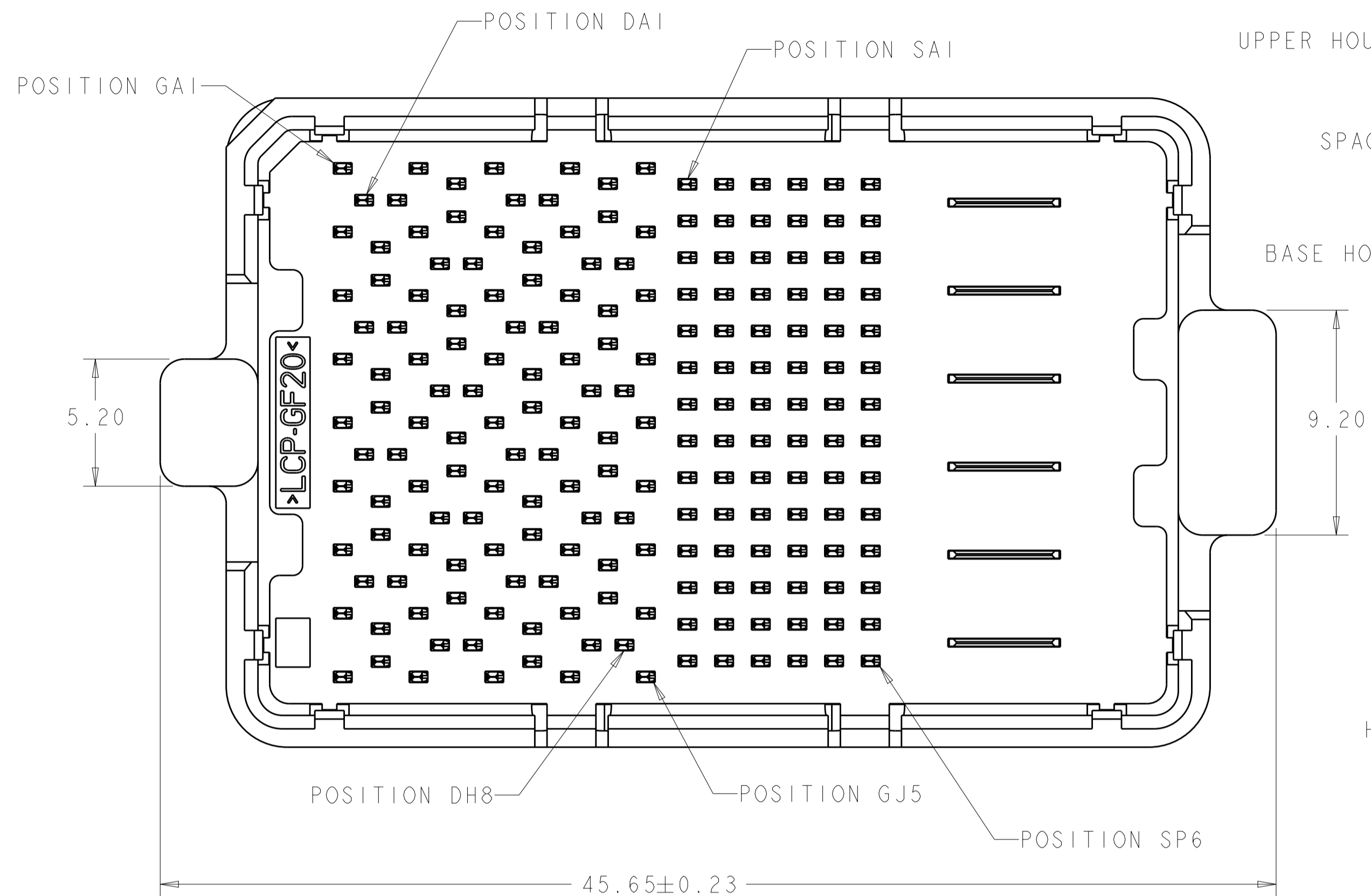
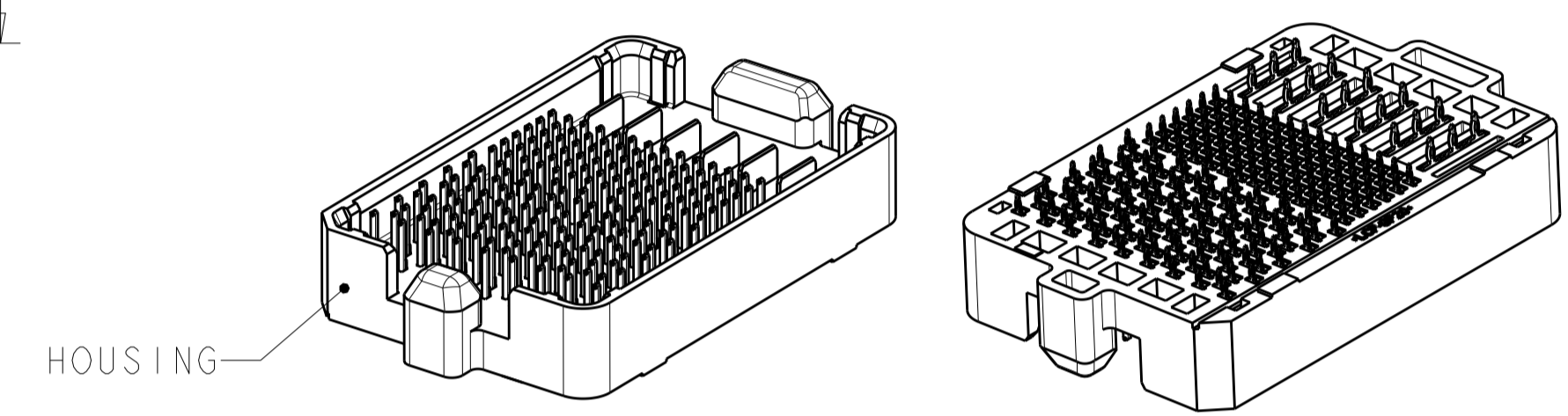

ISOMETRIC VIEW
TYPICAL CONFIGURATION FOR 8mm THRU 13mm
8mm SHOWN
SCALE 2:1

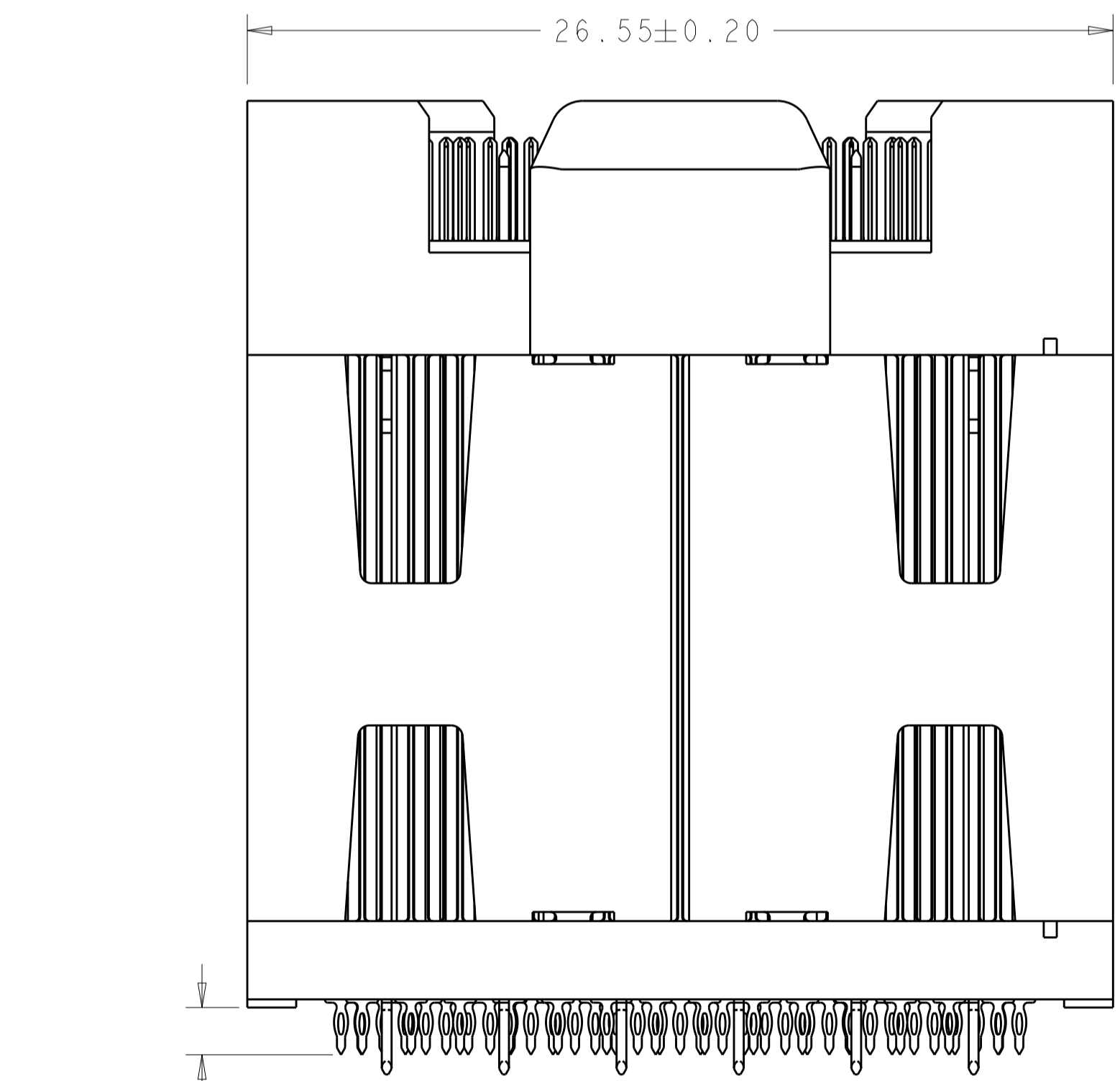
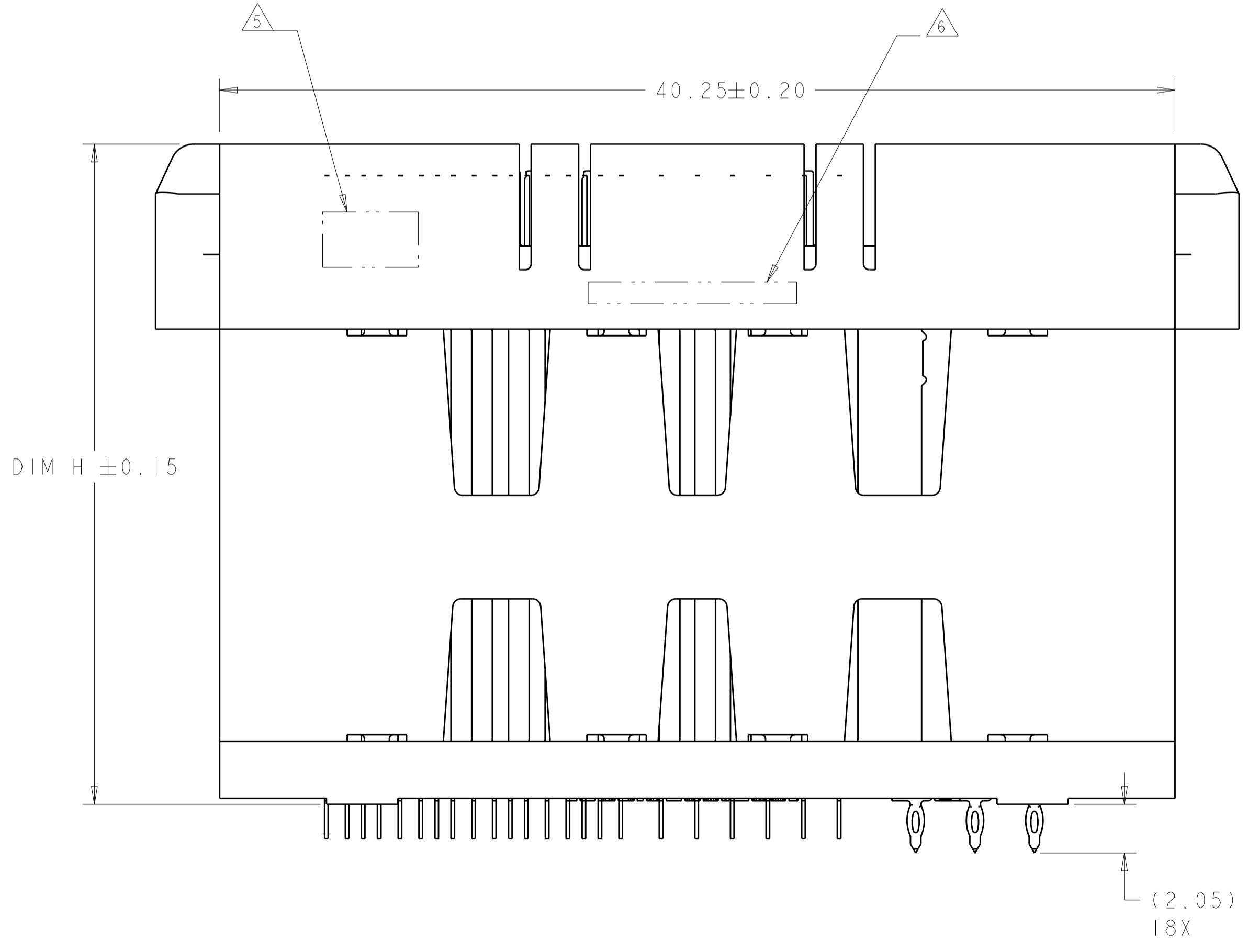

(1.45)
193X

- 1 MATERIAL:
BASE HOUSING, UPPER HOUSING, ORGANIZER,
AND SPACER: THERMOPLASTIC, FLAMMABILITY
RATING UL94-V0
CONTACT: COPPER ALLOY
- 2. CONFORMS TO THE REQUIREMENTS OF TE PRODUCT
SPECIFICATION, 108-2375; BASED ON TELCORDIA
GR-1217-CORE FOR SYSTEM QUALITY LEVEL III,
APPLICATIONS IN CONTROLLED ENVIRONMENTS
(CENTRAL OFFICE).
SEE TE PRODUCT SPECIFICATION 108-2375 FOR
TEST SEQUENCES.
- 3 ROWS GA THRU GJ (SHOWN DARKENED) ARE TYPICALLY
USED AS GROUNDS.
- 4 SPECIFIED POSITIONAL TOLERANCE DEFINES HOLE TO
HOLE LOCATION WITHIN HOLE PATTERN. POSITIONAL
TOLERANCE OF HOLE PATTERN TO FIDUCIAL MARKS
OR PCB DATUMS SHALL BE DEFINED BY CUSTOMER.
- 5 AREA RESERVED FOR TE CONNECTIVITY LOGO.
- 6 AREA RESERVED FOR PART NUMBER (X-XXXXXXX-X)
AND DATE CODE (YYWW).
- 7 USE CENTERLINES INDICATED ON PCB HOLE PATTERN
TO ESTABLISH ALIGNMENT BETWEEN HEADER AND
RECEPTACLE BOARDS.
- 8 PLATED THROUGH HOLE REQUIREMENTS - SIGNAL:
HOLE SIZE PRIOR TO PLATING = $\varnothing 0.420 \pm 0.013$
COPPER PLATING THICKNESS = 0.038 ± 0.013
CALCULATED FINISHED HOLE SIZE = $\varnothing 0.344 \pm 0.039$
THESE DIMENSIONS APPLY TO THE TOP 1.25mm OF
THE PCB THICKNESS FROM THE CONNECTOR MOUNTING
SIDE.
- 9 PLATED THROUGH HOLE REQUIREMENTS - POWER:
HOLE SIZE PRIOR TO PLATING = $\varnothing 0.700 \pm 0.025$
COPPER PLATING THICKNESS = 0.038 ± 0.013
CALCULATED FINISHED HOLE SIZE = $\varnothing 0.624 \pm 0.051$
THESE DIMENSIONS APPLY TO THE TOP 1.50mm OF
THE PCB THICKNESS FROM THE CONNECTOR MOUNTING
SIDE.

SIZE 2 HOUSING W/ GUIDE POSTS
32 DIFFERENTIAL PAIRS
84 HIGH-DENSITY GRID
193 TOTAL SIGNAL CONTACTS
6 POWER CONTACTS

10.8	11mm	MATTE Sn	6-2227706-1
DIM H	STACK HEIGHT	CONTACT TAIL PLATING	PART NUMBER

THIS DRAWING IS A CONTROLLED DOCUMENT.		OWN: M. HORNUNG	DATE: 13MAR2013
DIMENSIONS: mm		CHK: M. HORNUNG	DATE: 13MAR2013
TOLERANCES UNLESS OTHERWISE SPECIFIED:		APVD: -	NAME: -
0 PLC	±	PRODUCT SPEC	108-2375
2 PLC	±0.13	APPLICATION SPEC	114-13249
3 PLC	±0.013	SIZE	CAGE CODE DRAWING NO
4 PLC	±	WEIGHT	A100779C=2227706
ANGLES	±	Customer Drawing	SCALE 2:1 SHEET 1 OF 3 REV A
MATERIAL	FINISH	Customer Drawing	

LOC	DIST	REVISIONS			
P	LTN	DESCRIPTION	DATE	DWN	APVD
-	-	SEE SHEET 1	-	-	-

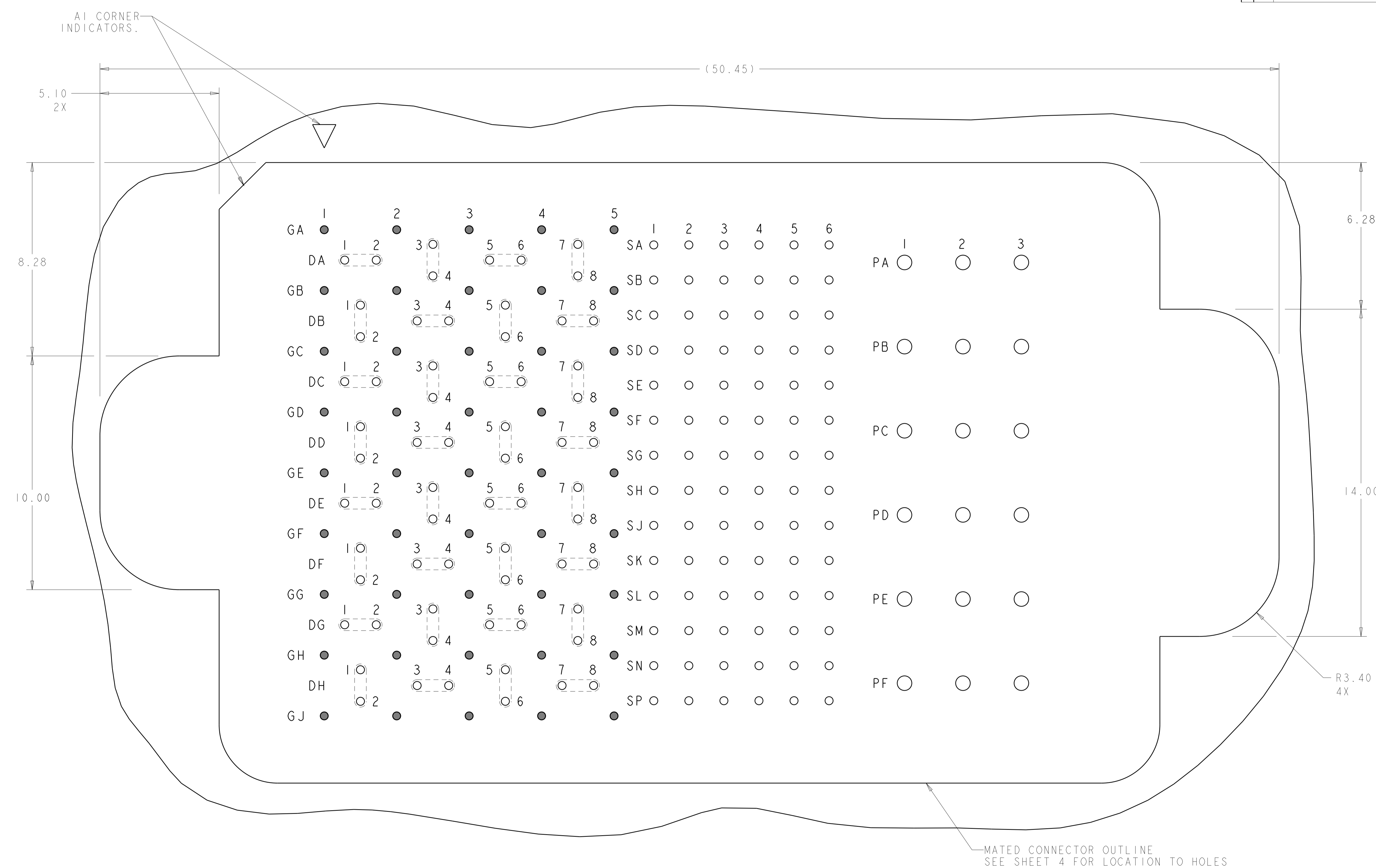

PCB LAYOUT AND PIN IDENTIFICATION
 SHOWN FROM CONNECTOR SIDE
 SCALE 12:1

THIS DRAWING IS A CONTROLLED DOCUMENT.		DWN M. HORNUNG TIMAR2013	TE Connectivity STE
DIMENSIONS:		CHK M. HORNUNG TIMAR2013	
mm	TOLERANCES UNLESS OTHERWISE SPECIFIED:	APVD	NAME
0 PLC ±	1 PLC ±	PRODUCT SPEC	HEADER ASSEMBLY
2 PLC ±0.13	3 PLC ±0.013	APPLICATION SPEC	32784/6P
4 PLC ±	ANGLES ±1	RESTRICTED TO	STRADA MESA MEZZANINE CONNECTOR
MATERIAL	FINISH	SIZE CAGE CODE DRAWING NO	A100779C=2227706
		WEIGHT	Customer Drawing
		SCALE	2:1
		SHEET	2 OF 3
		REV	A

