

Antenna Switch Control

The MDC5101 inputs TxE and RxE Logic Signals with an accessory input termination option and, allows positive and negative control voltages in accordance with the enclosed truth table. This device is primarily intended to control GaAs RF switches. It is also designed to interface with most HCMOS MCUs such as the ON Semiconductor MC68338.

The MDC5101 is intended to replace a circuit of up to 18 discrete components and is available in a Micro-8 package. This device, in combination with a compatible RF switch, can be used to achieve duplex isolation in any Time Division Duplex Radio like GSM and DCS1800 with staggered Transmit Receive Time Slots. It can also be used to control an RF switch in dual band radio applications.

This integrated solution in a Micro-8 package compared with a discrete solution will add a great value in performance with less board space consumption.

Features

- Miniature Micro-8 Surface Mount Package Saves Board Space
- Logic Level Control
- Designed to Interface with Microcontrollers

MAXIMUM RATINGS

Rating	Symbol	Value	Unit
Positive Power Supply Voltage ⁽¹⁾	V_{CC}	15	Vdc
Negative Power Supply Voltage ⁽²⁾	V_{EE}	-12	Vdc
Differential Power Supply Voltage	$V_{CC}-V_{EE}$	15	Vdc
Input Voltage ⁽³⁾	V_{in}	V_{CC}	Vdc
Output Current ⁽⁴⁾	I_1, I_2	5.0	mAdc
Operating Temperature Range	T_A	-40 to +85	°C
Storage Temperature Range	T_{stg}	-55 to +150	°C
Junction Temperature	T_J	150	°C

THERMAL CHARACTERISTICS

Characteristic	Symbol	Value	Unit
Total Power Dissipation Derate above 25°C	P_D	510 4.0	mW mW/°C
Thermal Resistance, Junction to Ambient	$R_{\theta JA}$	245	°C/W

Note 1: Pin 1 Referenced to Ground

Note 2: Pin 6 Referenced to Ground

Note 3: Pin 3, 4 Referenced to Ground

Note 4: Pin 5, 7 Referenced to Ground

DEVICE MARKING

5101

ORDERING INFORMATION

MDC5101R2 13 inch Reel, 4000 units

ESD Rating

ESD protection on each pin to ± 2500 V per MIL-STD6883 method 3015, using human body model of 100 pF, 1500 Ohms and using the machine model to ± 200 V at 100 pF and 0 Ohms. Parts must meet electrical requirement after testing.

MDC5101

ANTENNA SWITCH CONTROLLER



PLASTIC PACKAGE
CASE 846A-02
(Micro-8)

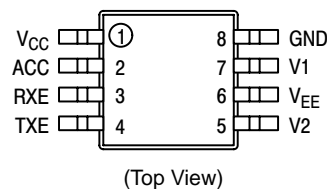

MDC5101

ELECTRICAL CHARACTERISTICS ($V_{CC} = 2.75\text{ V}$, $V_{EE} = -5.0\text{ V}$, $T_A = T_{low}$ to T_{high} unless otherwise noted)

Characteristic	Symbol	Min	Typ	Max	Unit
DC PARAMETERS					
Positive Power Supply Current V1, V2, ACC 10 k Ω to GND, RxE = V _{IH} , TxE = V _{IL}	I _{CC}	—	—	1.0	mA
Negative Power Supply Current V1, V2, ACC Open, RxE = V _{IL} , TxE = V _{IH}	I _{EE}	—	-50	—	μ A
Negative Power Supply Current V1, V2, ACC 10 k Ω to GND, RxE = V _{IL} , TxE = V _{IH}	I _{EE}	-1.5	—	—	mA
High Level Output Voltage I ₁ = I ₂ = 250 μ A, ACC Open RxE = V _{IL} , TxE = V _{IH} RxE = V _{IH} , TxE = V _{IL} I ₁ = I ₂ = 250 μ A, ACC 10 k Ω to GND RxE = V _{IL} , TxE = V _{IH} RxE = V _{IH} , TxE = V _{IL}	V _{OH} (V1) V _{OH} (V2) V _{OH} (V2) V _{OH} (V1)	V _{IH} -0.25 V _{IH} -0.25 V _{IH} -0.25 V _{IH} -0.25			Vdc
Low Level Output Voltage I ₁ = I ₂ = 250 μ A, ACC Open RxE = TxE = V _{IL} RxE = V _{IH} , TxE = V _{IL} I ₁ = I ₂ = 250 μ A, ACC 10 k Ω to GND RxE = TxE = V _{IL} RxE = V _{IH} , TxE = V _{IL}	V _{OL} (V1,V2) V _{OL} (V1) V _{OL} (V1,V2) V _{OL} (V2)	-0.5 -0.5 -0.5 -0.5	0 0	0.5 0.5	Vdc
Low Level Output Voltage I ₁ = I ₂ = 250 μ A, TxE = V _{IH} , RxE = V _{IL} ACC Open ACC 10 k Ω to GND	V _{OL} (V2) V _{OL} (V1)			-4.5 -4.5	Vdc

AC PARAMETERS

Propagation Delay RxE, TxE to V1, V2 ACC Open	t _{PLH} t _{PHL}	— —	— —	1.5 1.5	μ s
RxE, TxE to V1, V2 ACC 10 k Ω to GND	t _{PLH} t _{PHL}	— —	— —	1.5 1.5	
ACC to V1, V2	t _{PLH} t _{PHL}	— —	— —	5.0 5.0	

TRUTH TABLE

Input Logic			Output Logic		
RxE	TxE	ACC	V2	V1	
0	0	0	0	0	
0	0	1	0	0	
0	1	0	-5.0	2.7	
0	1	1	2.7	-5.0	
1	0	0	2.7	0	
1	0	1	0	2.7	
1	1	0	2.7	2.7	State not allowed in software
1	1	1	2.7	2.7	State not allowed in software

Note: ACC Logic Low = Open, ACC Logic High = 10 k Ω

Low Level Input Voltage RxE, TxE	V _{IL}	—	—	0.4	Vdc
High Level Input Voltage RxE, TxE	V _{IH}	2.5	—	—	
Maximum Voltage Differential	V _{CC} -V _{IH}	—	—	1.5	

MDC5101

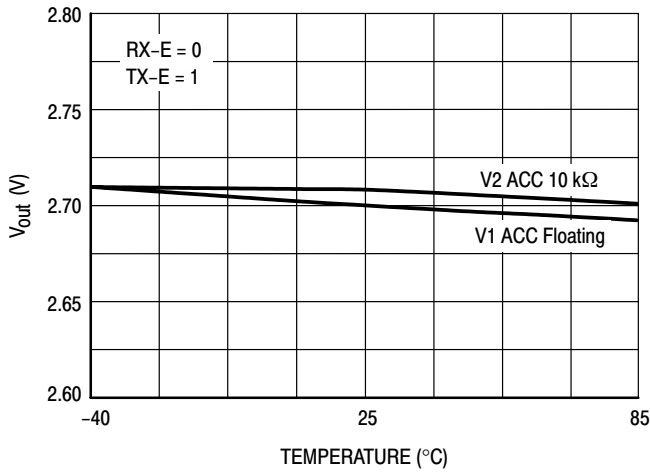

Figure 1. V_{out} (high) versus Temperature

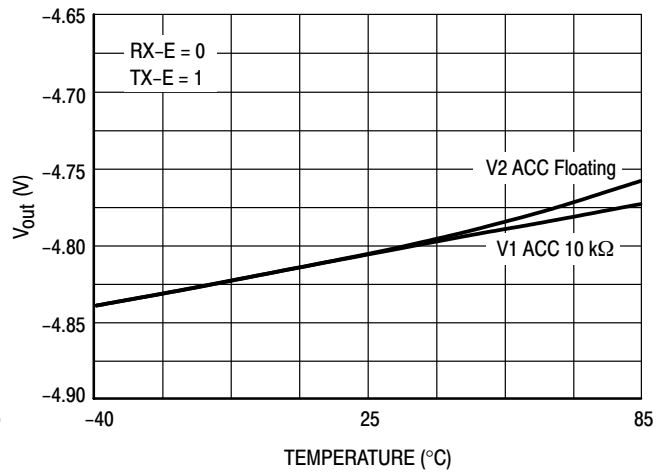

Figure 2. V_{out} (low) versus Temperature

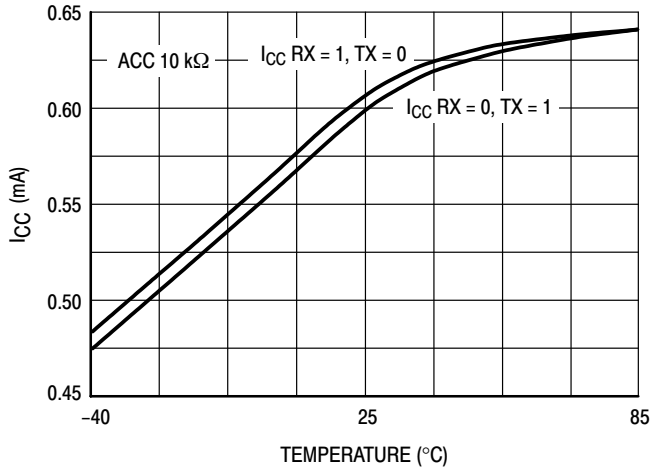

Figure 3. I_{CC} versus Temperature

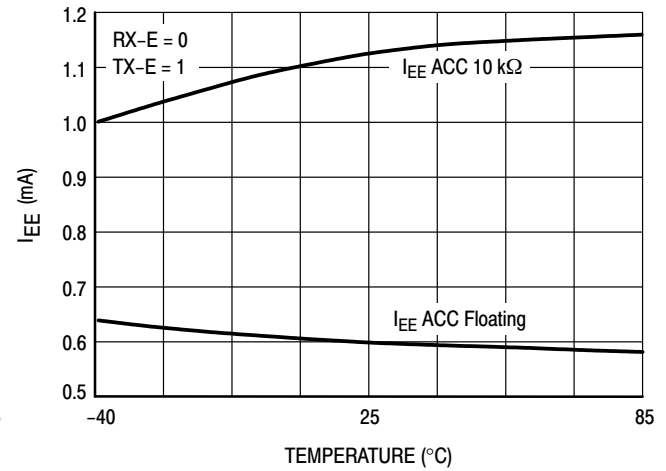

Figure 4. I_{EE} versus Temperature

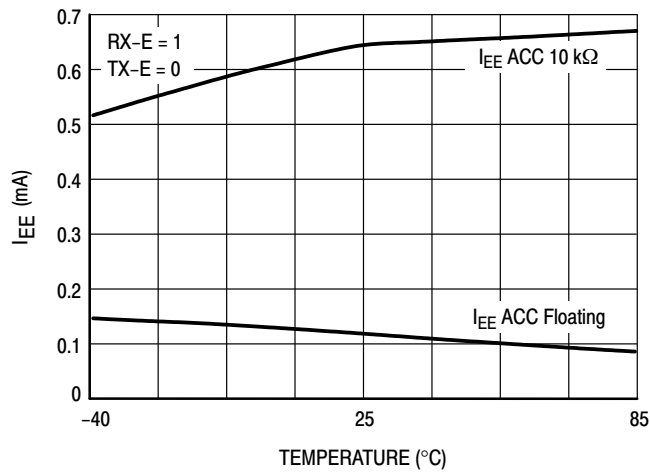

Figure 5. I_{EE} versus Temperature

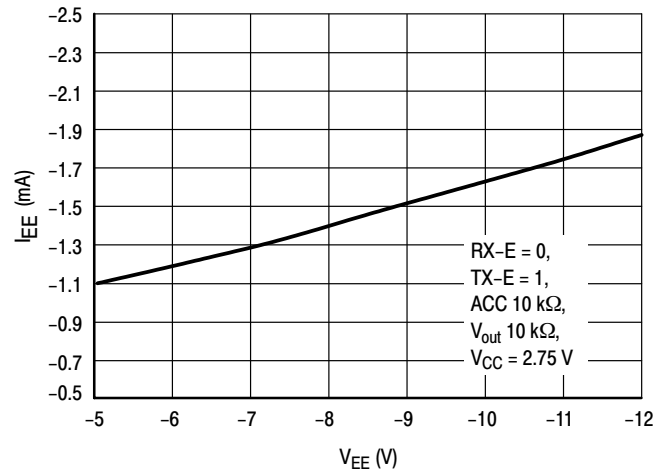

Figure 6. I_{EE} versus V_{EE}

MDC5101

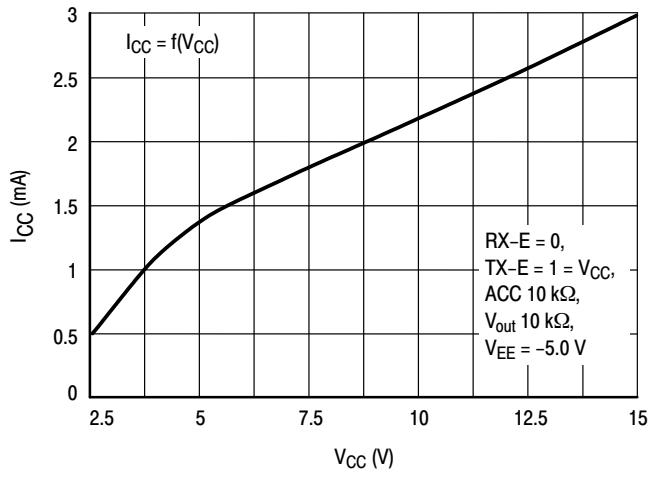

Figure 7. I_{CC} versus V_{CC}

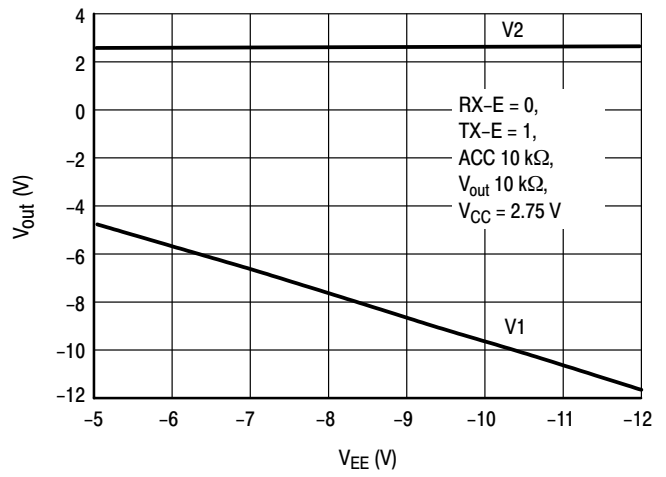

Figure 8. V_{out} versus V_{EE}

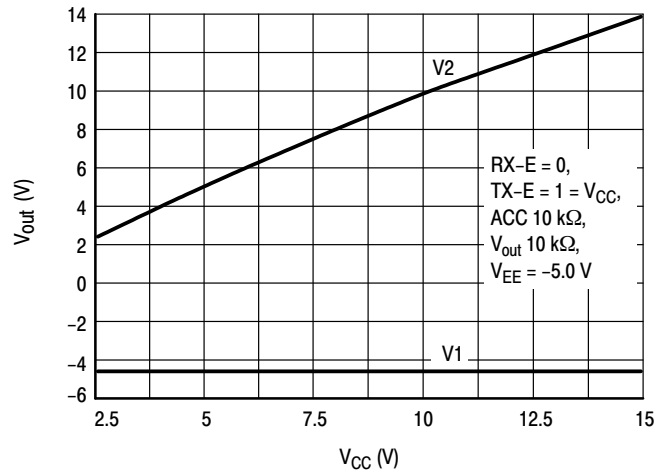

Figure 9. V_{out} versus V_{IH}/V_{CC}

MDC5101

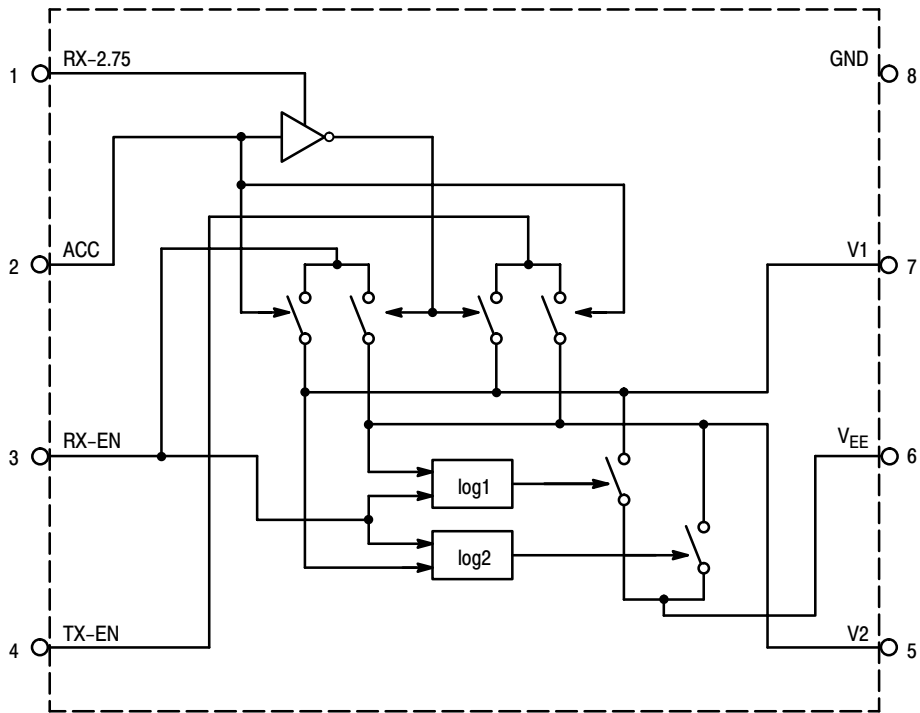

Figure 10. Antenna Switch Controller Block Diagram

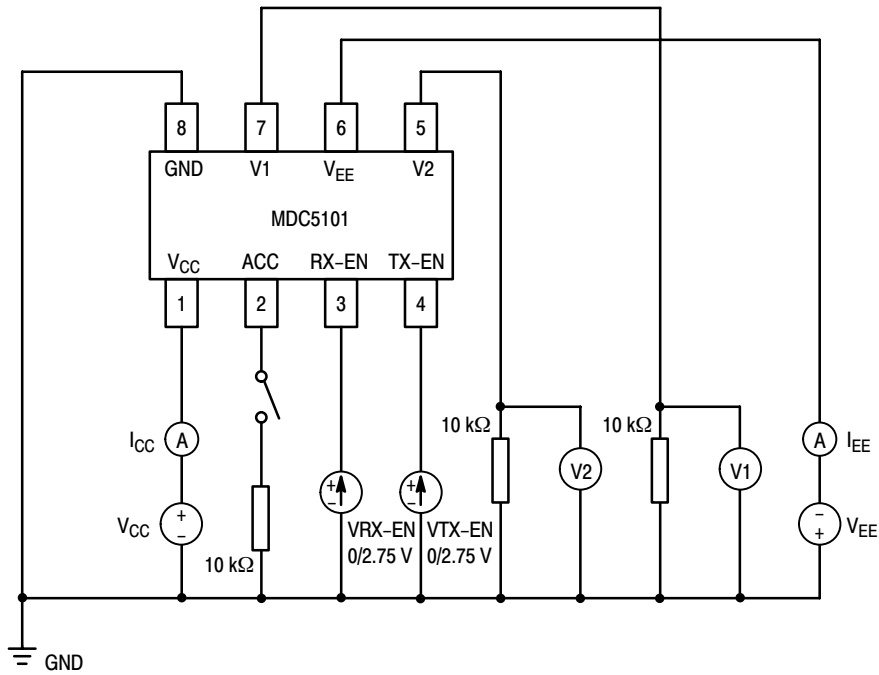

Figure 11. Temperature Measurement Schematic

MDC5101

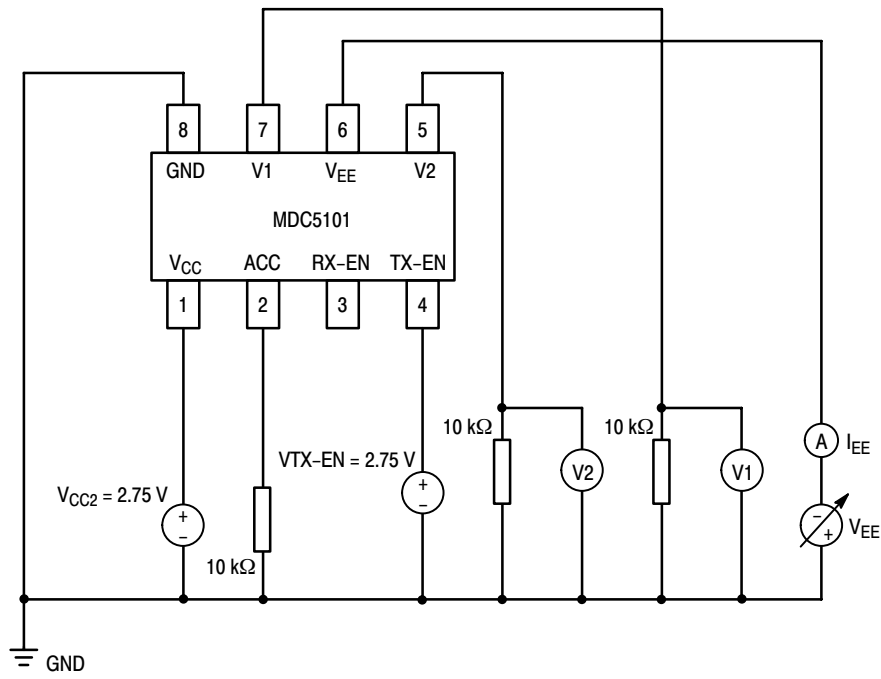

Figure 12. Measurement Schematic
V_{out} vs V_{EE} & I_{EE} vs V_{EE}

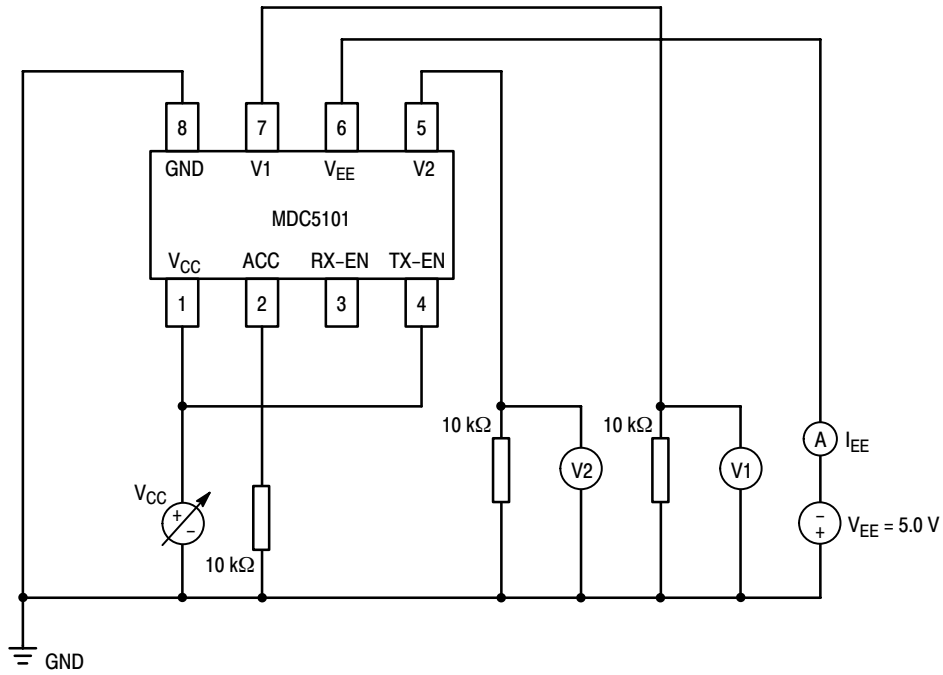
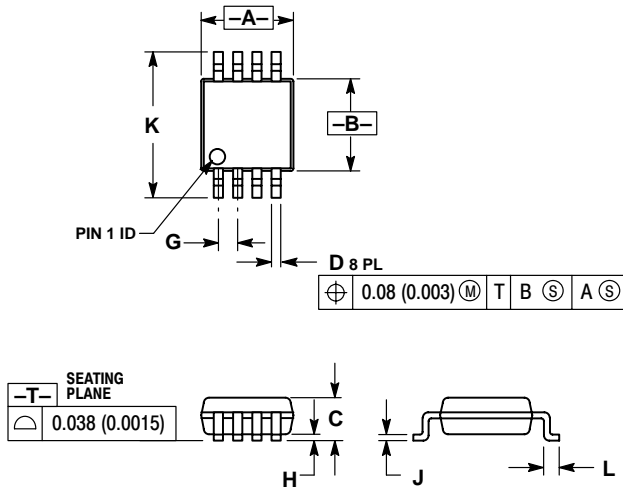

Figure 13. Measurement Schematic
V_{out} vs V_{CC}

MDC5101

PACKAGE DIMENSIONS

Micro8
CASE 846A-02
ISSUE E



NOTES:

1. DIMENSIONING AND TOLERANCING PER ANSI Y14.5M, 1982.
2. CONTROLLING DIMENSION: MILLIMETER.
3. DIMENSION A DOES NOT INCLUDE MOLD FLASH, PROTRUSIONS OR GATE BURRS. MOLD FLASH, PROTRUSIONS OR GATE BURRS SHALL NOT EXCEED 0.15 (0.006) PER SIDE.
4. DIMENSION B DOES NOT INCLUDE INTERLEAD FLASH OR PROTRUSION. INTERLEAD FLASH OR PROTRUSION SHALL NOT EXCEED 0.25 (0.010) PER SIDE.

DIM	MILLIMETERS		INCHES	
	MIN	MAX	MIN	MAX
A	2.90	3.10	0.114	0.122
B	2.90	3.10	0.114	0.122
C	---	1.10	---	0.043
D	0.25	0.40	0.010	0.016
G	0.65 BSC		0.026 BSC	
H	0.05	0.15	0.002	0.006
J	0.13	0.23	0.005	0.009
K	4.75	5.05	0.187	0.199
L	0.40	0.70	0.016	0.028

ON Semiconductor and  are trademarks of Semiconductor Components Industries, LLC (SCILLC). SCILLC reserves the right to make changes without further notice to any products herein. SCILLC makes no warranty, representation or guarantee regarding the suitability of its products for any particular purpose, nor does SCILLC assume any liability arising out of the application or use of any product or circuit, and specifically disclaims any and all liability, including without limitation special, consequential or incidental damages. "Typical" parameters which may be provided in SCILLC data sheets and/or specifications can and do vary in different applications and actual performance may vary over time. All operating parameters, including "Typicals" must be validated for each customer application by customer's technical experts. SCILLC does not convey any license under its patent rights nor the rights of others. SCILLC products are not designed, intended, or authorized for use as components in systems intended for surgical implant into the body, or other applications intended to support or sustain life, or for any other application in which the failure of the SCILLC product could create a situation where personal injury or death may occur. Should Buyer purchase or use SCILLC products for any such unintended or unauthorized application, Buyer shall indemnify and hold SCILLC and its officers, employees, subsidiaries, affiliates, and distributors harmless against all claims, costs, damages, and expenses, and reasonable attorney fees arising out of, directly or indirectly, any claim of personal injury or death associated with such unintended or unauthorized use, even if such claim alleges that SCILLC was negligent regarding the design or manufacture of the part. SCILLC is an Equal Opportunity/Affirmative Action Employer.

PUBLICATION ORDERING INFORMATION

Literature Fulfillment:

Literature Distribution Center for ON Semiconductor
P.O. Box 5163, Denver, Colorado 80217 USA
Phone: 303-675-2175 or 800-344-3860 Toll Free USA/Canada
Fax: 303-675-2176 or 800-344-3867 Toll Free USA/Canada
Email: ONlit@hibbertco.com

N. American Technical Support: 800-282-9855 Toll Free USA/Canada

JAPAN: ON Semiconductor, Japan Customer Focus Center
4-32-1 Nishi-Gotanda, Shinagawa-ku, Tokyo, Japan 141-0031
Phone: 81-3-5740-2700
Email: r14525@onsemi.com

ON Semiconductor Website: <http://onsemi.com>

For additional information, please contact your local Sales Representative.