



8 dBi Panel Antenna 902-928 MHz N Type Connector

Antennas Technical Data Sheet

PE51FP1005-1

Features

- Vertical or Horizontal Polarization
- Light Weight
- Low Loss
- 4 ft. Coax Lead
- Durable UV Stable
- UL Flame Rated Radome

Applications

- Cellular, GSM
- Wireless LAN Systems
- 900 MHz ISM Band
- LPWAN, LoRA, IoT, M2M Applications
- SCADA, RFID

Description

The Pasternack PE51FP1005-1 high gain flat panel antenna provides 8 dBi gain with broad coverage. It is suitable for both indoor and outdoor wireless LAN and wireless video applications in the 900MHz ISM band, GSM, 900MHz cellular, RFID, LPWAN, IoT, and M2M applications.

The N-male connectorized PE51FP1005-1 construction features sealed internal elements and an aesthetic UV-stable, UL flame rated white plastic radome. Can be wall or mast mounted using U-bolts.

This flat panel antenna, as well as our wide selection of superior quality RF devices, ships same day. Contact our knowledgeable and friendly technical support and sales staff for your answers on antennas or other Pasternack products.

Configuration

Design	Panel
Application Band	RFID SCADA LPWAN ISM
Band Type	Single
Radiation Pattern	Directional
Polarization	Vertical or Horizontal
Cable Type	Coax lead
Cable Length	48 in [121.92 cm]
Connector Type	N Male
Number of Ports	1

Electrical Specifications

Description	Minimum	Typical	Maximum	Units
Frequency Range	902		928	MHz
Input VSWR		1.5:1	1.5:1	
Impedance		50		Ohms
Gain		8		dBi
Horizontal (Azimuth) Beam Width		75		Degrees
Vertical (Elevation) Beam Width		65		Degrees

Click the following link (or enter part number in "SEARCH" on website) to obtain additional part information including price, inventory and certifications: [8 dBi Panel Antenna 902-928 MHz N Type Connector PE51FP1005-1](#)



8 dBi Panel Antenna 902-928 MHz N Type Connector

Antennas Technical Data Sheet

PE51FP1005-1

Specifications by Band

Description	Band 1	Band 2	Band 3	Band 4	Band 5	Units
Range	902-928					MHz
Gain	8					dBi
Horizontal Beam Width	75					Degrees
Vertical Beam Width	65					Degrees

Mechanical Specifications

Radome Material ASA

Size

Overall Length 8.5 in [215.9 mm]
 Width 8.5 in [215.9 mm]
 Height 1.2 in [30.48 mm]
 Weight 1.17 lbs [530.7 g]
 Color White

Environmental Specifications

Temperature

Operating Range -20 to +60 deg C

Environment UL-94HB

Wind Loading 150 MPH [241.4 KPH]

Compliance Certifications (see [product page](#) for current document)

Plotted and Other Data

Notes:

Click the following link (or enter part number in "SEARCH" on website) to obtain additional part information including price, inventory and certifications: [8 dBi Panel Antenna 902-928 MHz N Type Connector PE51FP1005-1](#)



8 dBi Panel Antenna 902-928 MHz N Type Connector

Antennas Technical Data Sheet

PE51FP1005-1

8 dBi Panel Antenna 902-928 MHz N Type Connector from Pasternack Enterprises has same day shipment for domestic and International orders. Our RF, microwave and millimeter wave products maintain a 99.4% availability and are part of the broadest selection in the industry.

Click the following link (or enter part number in "SEARCH" on website) to obtain additional part information including price, inventory and certifications: [8 dBi Panel Antenna 902-928 MHz N Type Connector PE51FP1005-1](#)

URL: <https://www.pasternack.com/single-antenna-902-928-mhz-8-dbi-gain-n-pe51fp1005-1-p.aspx>

The information contained in this document is accurate to the best of our knowledge and representative of the part described herein. It may be necessary to make modifications to the part and/or the documentation of the part, in order to implement improvements. Pasternack reserves the right to make such changes as required. Unless otherwise stated, all specifications are nominal. Pasternack does not make any representation or warranty regarding the suitability of the part described herein for any particular purpose, and Pasternack does not assume any liability arising out of the use of any part or documentation.

PE51FP1005-1 CAD Drawing

8 dBi Panel Antenna 902-928 MHz N Type Connector

REVISIONS			
REV.	DESCRIPTION	DATE	APPROVED
A	INITIAL RELEASE	8/5/2020	K.HIETPAS

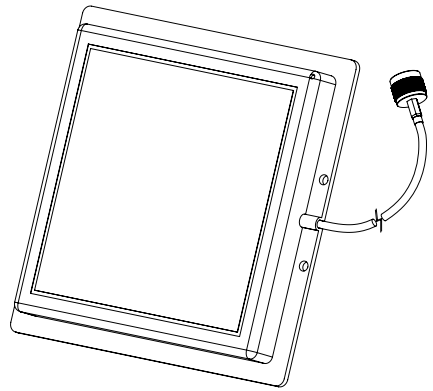
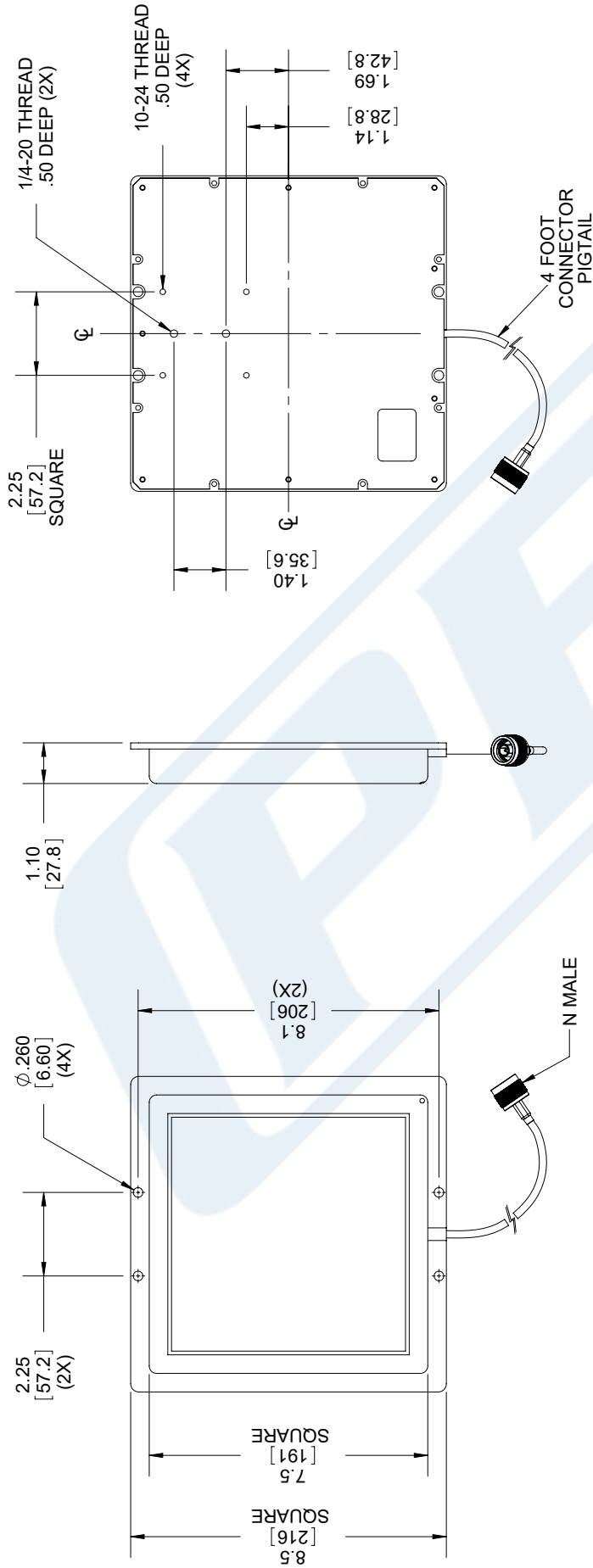

UNLESS OTHERWISE SPECIFIED LEADING DIMENSIONS ARE INCHES DIMENSIONS IN [] ARE MILLIMETERS

TOLERANCES:

.X = ± .2	[5.08]	FRACTIONS	± 1/32
.XX = ± .02	[.51]	ANGLES ± 1°	
.XXX = ± .005	[.13]	CABLE LENGTH (L) TOLERANCES:	
L ≤ 12 [305] = +1 [25] / -0			
12 [305] < L ≤ 60 [1524] = +2 [51] / -0			
60 [1524] < L ≤ 120 [3048] = +4 [102] / -0			
120 [3048] < L ≤ 300 [7620] = +6 [152] / -0			
300 [7620] < L = +5% / -0			

ALL DIMENSIONS SHOWN ARE FOR REFERENCE ONLY.

THIRD-ANGLE PROJECTION

THE INFORMATION AND DESIGN IN THIS DOCUMENT IS THE PROPERTY OF PASTERNAK CORPORATION ALL RIGHTS RESERVED.

SHEET 1 OF 1

SCALE N/A

Pasternack Enterprises, Inc.
 P. O. Box 16759, Irvine, CA 92623.
 Phone: 1.949.261.1920 | 1.866.727.8376
 Fax: 1.949.261.7451
 Website: www.pasternack.com
 E-mail: sales@pasternack.com

SIZE	CAGE CODE	DRAWN BY	ITEM NO
A	53919	K. DANG	PE51FP1005-1
REV			REV
			A

REGULATORY COMPLIANCE:
 EU ROHS DIRECTIVE (MOST RECENT RELEASED VERSION)

THESE COMMODITIES, TECHNOLOGY OR SOFTWARE WERE EXPORTED FROM THE UNITED STATES IN ACCORDANCE WITH THE EXPORT ADMINISTRATION REGULATIONS. DIVERSION CONTRARY TO U.S. LAW PROHIBITED.