

# SLIDE SWITCHES (SMD)

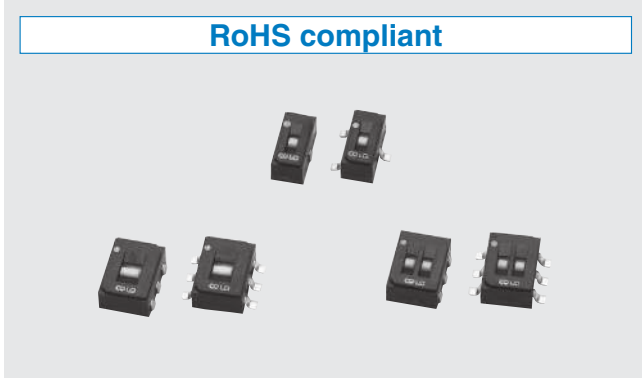

## RoHS compliant



## FEATURES

- RoHS compliant
- Compatible with most automatic pick & place machinery
- Compact and space saving SMD type
- Excellent contact stability by twin Gold-plated contact
- Low profile design of 2.5 mm

## INTERNAL STRUCTURE

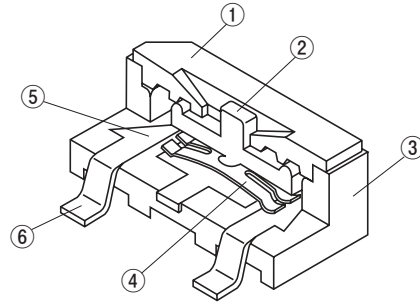

Part name	Material	Flammability
① Cover	Polyphenylenesulphide	UL94V-0
② Slider	Polyamide	
③ Housing	Polyphenylenesulphide	
④ Slider contact	Copper alloy, Gold-plated	—
⑤ Fixed contact		
⑥ Terminal pin		

## PART NUMBER DESIGNATION

**C A S - 1 2 0 T B 1**

Series name

No. of poles

1 : (SPDT) 1 pole, 2 : (2PDT) 2 poles  
D : (Dual SPDT) Dual

No. of contacts

2 : 2 contacts

Setting position

0 : Top setting

Form of packaging

T : Taping (Reel)  
Blank : Bulk in plastic bag

Structure

1 : Non-washable type (Without seal tape)  
Standard type  
2 : Non-washable type (With seal tape)  
Blank : Washable type (With seal tape)

Shape of terminal

A : J-hook  
B : Gull wing

SPDT : Single Pole Double Throw    2PDT : Two Poles Double Throw

※ Please refer to the LIST OF PART NUMBERS when placing orders.

# CAS

## SLIDE SWITCHES (SMD)

### LIST OF PART NUMBERS

No. of poles	No. of contacts	Setting position	Form of packaging	Non-washable type (Without seal tape)		Non-washable type (With seal tape)		Pieces in package
				A ( J-hook )	B ( Gull wing )	A ( J-hook )	B ( Gull wing )	
1	2	Top setting	Taping	CAS-120TA1	CAS-120TB1	CAS-120TA2	CAS-120TB2	1000pcs./reel
			Plastic bag	CAS-120A1	CAS-120B1	CAS-120A2	CAS-120B2	100pcs./pack
2			Taping	CAS-220TA1	CAS-220TB1	CAS-220TA2	CAS-220TB2	1000pcs./reel
			Plastic bag	CAS-220A1	CAS-220B1	CAS-220A2	CAS-220B2	100pcs./pack
Dual			Taping	CAS-D20TA1	CAS-D20TB1	CAS-D20TA2	CAS-D20TB2	1000pcs./reel
			Plastic bag	CAS-D20A1	CAS-D20B1	CAS-D20A2	CAS-D20B2	100pcs./pack

No. of poles	No. of contacts	Setting position	Form of packaging	Washable type (With seal tape)		Pieces in package
				A ( J-hook )	B ( Gull wing )	
1	2	Top setting	Taping	CAS-120TA	CAS-120TB	1000pcs./reel
			Plastic bag	CAS-120A	CAS-120B	100pcs./pack
2			Taping	CAS-220TA	CAS-220TB	1000pcs./reel
			Plastic bag	CAS-220A	CAS-220B	100pcs./pack
Dual			Taping	CAS-D20TA	CAS-D20TB	1000pcs./reel
			Plastic bag	CAS-D20A	CAS-D20B	100pcs./pack

※ Verify the above part numbers when placing orders.  
Taping version can be supplied only in reel unit.

## STANDARD SPECIFICATIONS

Operating temp. range	- 40 ~ 85 °C
Storage temp. range	
Sealing	Washable type available with seal tape
Net weight	Approx. 0.05g (CAS-120) Approx. 0.08g (CAS-220/D20)

## ELECTRICAL CHARACTERISTICS

Contact rating Non-switching Switching Minimum	DC50 V 100 mA DC6 V, 100 mA DC24 V, 25 mA DC20 mV 1 $\mu$ A
Contact resistance	50 m $\Omega$ maximum
Insulation resistance	1000 M $\Omega$ (DC100 V) minimum
Dielectric strength	AC500 V, 60 s

## MECHANICAL CHARACTERISTICS

Operating force	0.5 ~ 5 N {0.05 ~ 0.51 kgf}
Stop strength	10 N {1.02 kgf}, 60 s
Solderability	245 $\pm$ 3 °C, 2 ~ 3 s
Soldering heat	Reflow : 255 °C (Peak temperature) (Please refer to the profile below)
	Manual soldering : 350 $\pm$ 10 °C, 3 ~ 4 s
Shear (Adhesion)	5 N {0.51 kgf} 10 s
Substrate bending	Width 90 mm, bend 3 mm, 5 s, 1 time
Pull-off strength	5 N {0.51 kgf} 10 s

{ } : Reference only

## ENVIRONMENTAL CHARACTERISTICS

Vibration	(Amplitude) 1.5 mmor (Acceleration) 98 m/s <sup>2</sup> , 10-500 Hz, 3 directions for 10 cycles each
Shock	490 m/s <sup>2</sup> , 11 ms 6 directions for 3 times each
Load life	Continuous load 2000 cycles, DC6 $\pm$ 0.5 V, 100 $\pm$ 10 mA
Humidity	- 10 ~ 65 °C, Relative humidity 0 ~ 96 %, 24 h for 10 cycles
High temp. exposure	85 °C, 96 h
Low temp. exposure	- 40 °C, 96 h
Thermal shock	- 40 (0.5 h) ~ 85 °C (0.5 h), 5 cycles

### <Reflow profile for soldering heat evaluation>

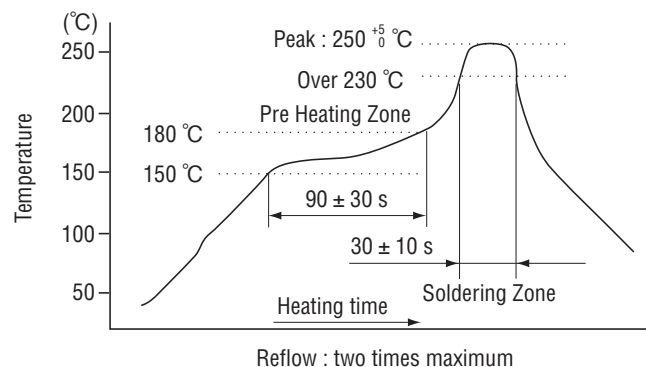

# CAS

## SLIDE SWITCHES (SMD)

### OUTLINE DIMENSIONS

Unless otherwise specified, tolerance :  $\pm 0.3$  (Unit : mm)

#### CAS-120A1

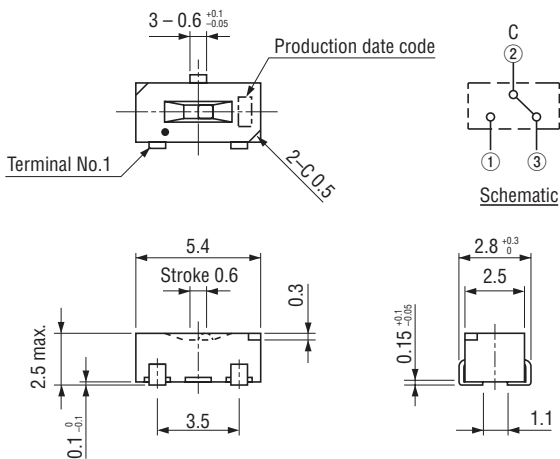

#### CAS-120B1

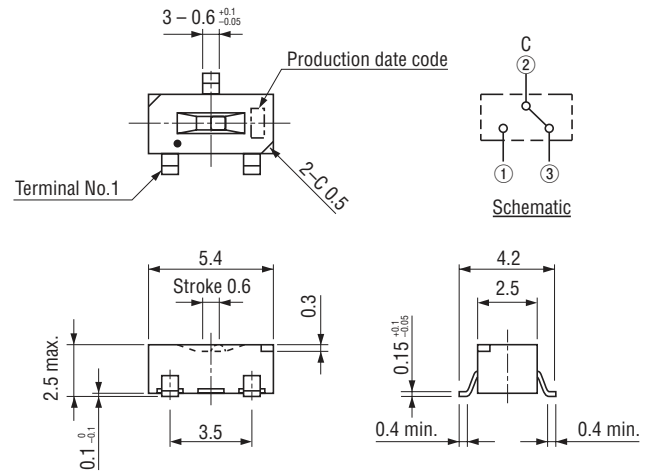

#### CAS-220A1

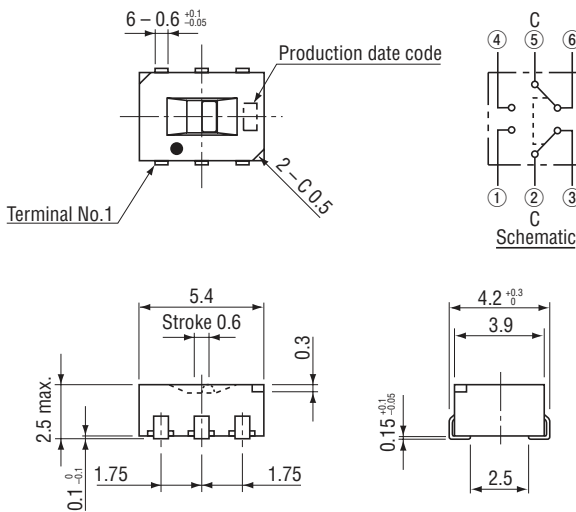

#### CAS-220B1

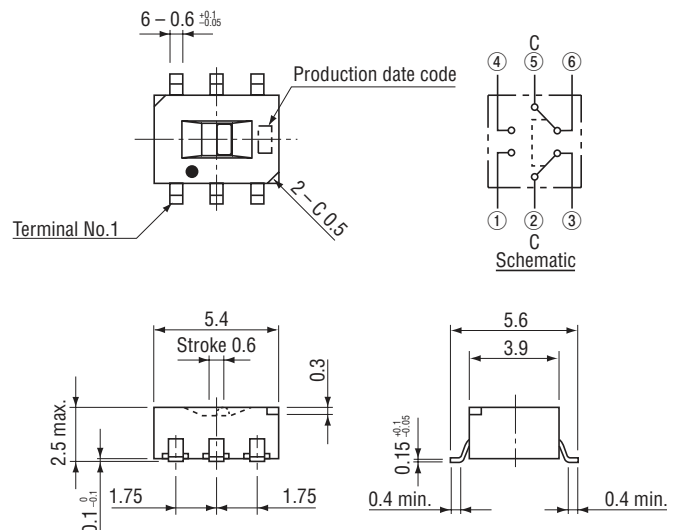

#### CAS-D20A1

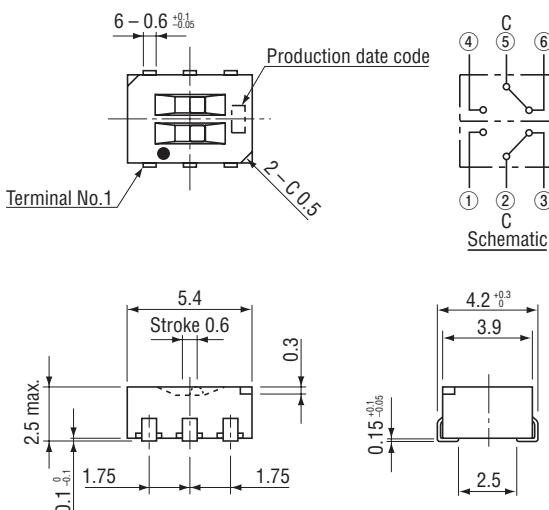

#### CAS-D20B1

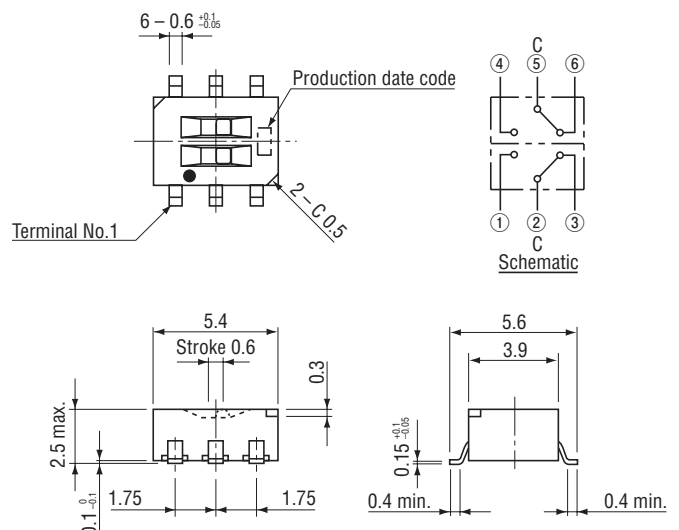

## RECOMMENDED P.C.B. PAD OUTLINE DIMENSIONS

### ● CAS-120

(Unit : mm)

#### A type

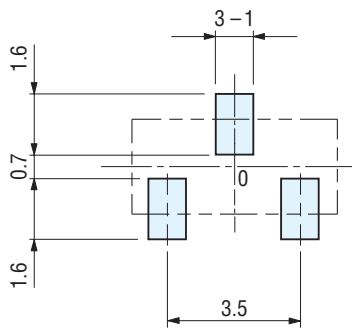

#### B type

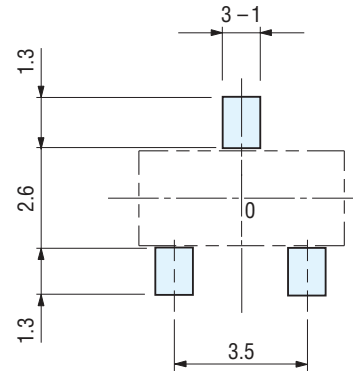

### ● CAS-220 • D20

#### A type

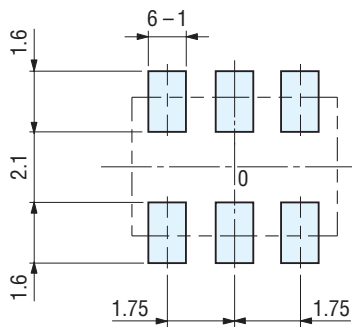

#### B type

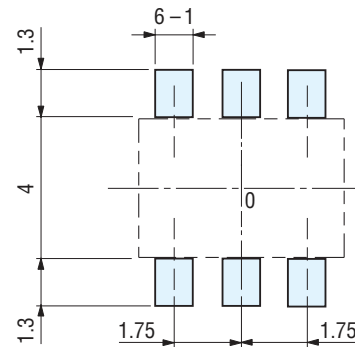

Note) The zero point is the center of mounting.

# CAS

## SLIDE SWITCHES (SMD)

### PACKAGING SPECIFICATIONS

#### <Taping packaging specifications>

- Taping version is packaged in 1000 pcs. per reel.  
Orders will be accepted for units of 1000 pcs., i.e., 1000, 2000, 3000 pcs., etc.
- Taping version is boxed with two reels (2000 pcs.).

Maximum number of consecutive missing pieces=2  
Leader length and reel dimension are shown in the diagrams below:

#### ● Embossed tape dimensions

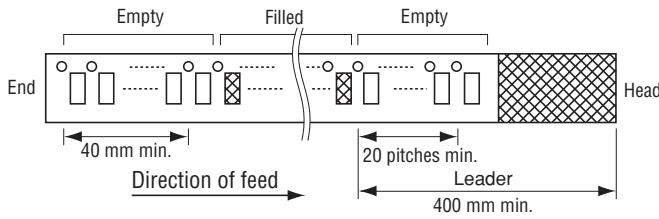

#### ● Reel dimensions

(Unit: mm)  
(Conforms to JIS C 0806-3)

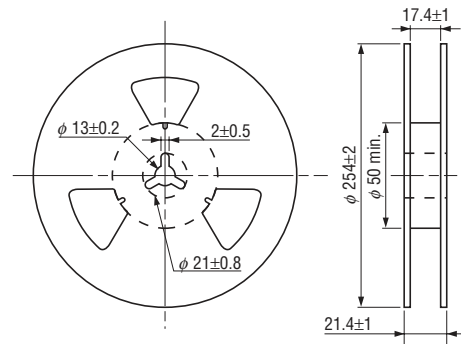

#### ● CAS-120TA, TB

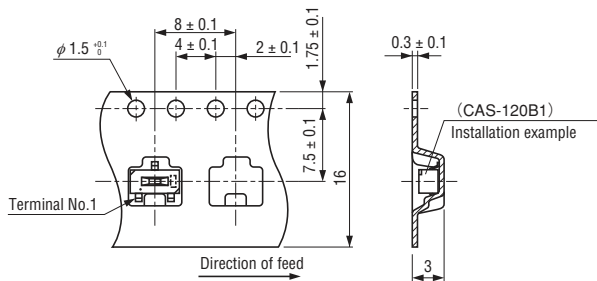

#### ● CAS-220TA, TB • D20TA, TB

(Conforms to JIS C 0806-3)  
(In accordance with EIAJ ET-7200A)

(Unit: mm)

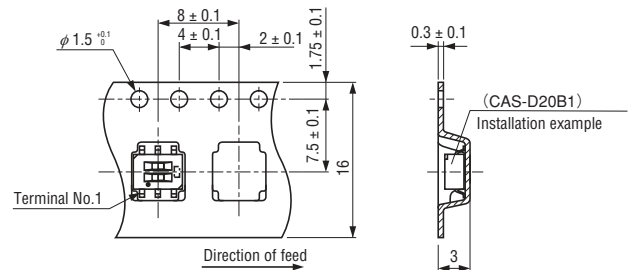

#### <Bulk pack specifications>

- Boxing of bulk pack in a plastic bag is performed with 100 pcs. (standard 500 pcs.) per box.