

# DATA SHEET

For a complete data sheet, please also download:

- The IC06 74HC/HCT/HCU/HCMOS Logic Family Specifications
- The IC06 74HC/HCT/HCU/HCMOS Logic Package Information
- The IC06 74HC/HCT/HCU/HCMOS Logic Package Outlines

## **74HC/HCT173**

**Quad D-type flip-flop; positive-edge trigger; 3-state**

Product specification  
File under Integrated Circuits, IC06

December 1990

## Quad D-type flip-flop; positive-edge trigger; 3-state

## 74HC/HCT173

## FEATURES

- Gated input enable for hold (do nothing) mode
- Gated output enable control
- Edge-triggered D-type register
- Asynchronous master reset
- Output capability: bus driver
- I<sub>CC</sub> category: MSI

## GENERAL DESCRIPTION

The 74HC/HCT173 are high-speed Si-gate CMOS devices and are pin compatible with low power Schottky TTL (LSTTL). They are specified in compliance with JEDEC standard no. 7A.

The 74HC/HCT173 are 4-bit parallel load registers with clock enable control, 3-state buffered outputs (Q<sub>0</sub> to Q<sub>3</sub>) and master reset (MR).

When the two data enable inputs ( $\bar{E}_1$  and  $\bar{E}_2$ ) are LOW, the data on the D<sub>n</sub> inputs is loaded into the register

synchronously with the LOW-to-HIGH clock (CP) transition. When one or both  $\bar{E}_n$  inputs are HIGH one set-up time prior to the LOW-to-HIGH clock transition, the register will retain the previous data. Data inputs and clock enable inputs are fully edge-triggered and must be stable only one set-up time prior to the LOW-to-HIGH clock transition.

The master reset input (MR) is an active HIGH asynchronous input. When MR is HIGH, all four flip-flops are reset (cleared) independently of any other input condition.

The 3-state output buffers are controlled by a 2-input NOR gate. When both output enable inputs ( $\bar{OE}_1$  and  $\bar{OE}_2$ ) are LOW, the data in the register is presented to the Q<sub>n</sub> outputs. When one or both  $\bar{OE}_n$  inputs are HIGH, the outputs are forced to a high impedance OFF-state. The 3-state output buffers are completely independent of the register operation; the  $\bar{OE}_n$  transition does not affect the clock and reset operations.

## QUICK REFERENCE DATA

GND = 0 V; T<sub>amb</sub> = 25 °C; t<sub>r</sub> = t<sub>f</sub> = 6 ns

SYMBOL	PARAMETER	CONDITIONS	TYPICAL		UNIT
			HC	HCT	
t <sub>PHL</sub> / t <sub>PLH</sub>	propagation delay CP to Q <sub>n</sub> MR to Q <sub>n</sub>	C <sub>L</sub> = 15 pF; V <sub>CC</sub> = 5 V	17	17	ns
			13	17	ns
f <sub>max</sub>	maximum clock frequency		88	88	MHz
C <sub>I</sub>	input capacitance		3.5	3.5	pF
C <sub>PD</sub>	power dissipation capacitance per flip-flop	notes 1 and 2	20	20	pF

## Notes

1. C<sub>PD</sub> is used to determine the dynamic power dissipation (P<sub>D</sub> in μW):

$$P_D = C_{PD} \times V_{CC}^2 \times f_i + \sum (C_L \times V_{CC}^2 \times f_o) \text{ where:}$$

f<sub>i</sub> = input frequency in MHz

f<sub>o</sub> = output frequency in MHz

∑ (C<sub>L</sub> × V<sub>CC</sub><sup>2</sup> × f<sub>o</sub>) = sum of outputs

C<sub>L</sub> = output load capacitance in pF

V<sub>CC</sub> = supply voltage in V

2. For HC the condition is V<sub>I</sub> = GND to V<sub>CC</sub>  
For HCT the condition is V<sub>I</sub> = GND to V<sub>CC</sub> - 1.5 V

## ORDERING INFORMATION

See "74HC/HCT/HCU/HCMOS Logic Package Information".

Quad D-type flip-flop; positive-edge trigger; 3-state

74HC/HCT173

PIN DESCRIPTION

PIN NO.	SYMBOL	NAME AND FUNCTION
1, 2	$\overline{OE}_1, \overline{OE}_2$	output enable input (active LOW)
3, 4, 5, 6	$Q_0$ to $Q_3$	3-state flip-flop outputs
7	CP	clock input (LOW-to-HIGH, edge-triggered)
8	GND	ground (0 V)
9, 10	$\overline{E}_1, \overline{E}_2$	data enable inputs (active LOW)
14, 13, 12, 11	$D_0$ to $D_3$	data inputs
15	MR	asynchronous master reset (active HIGH)
16	$V_{CC}$	positive supply voltage

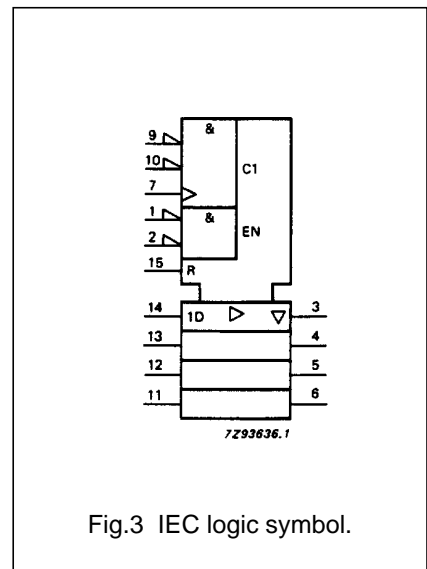
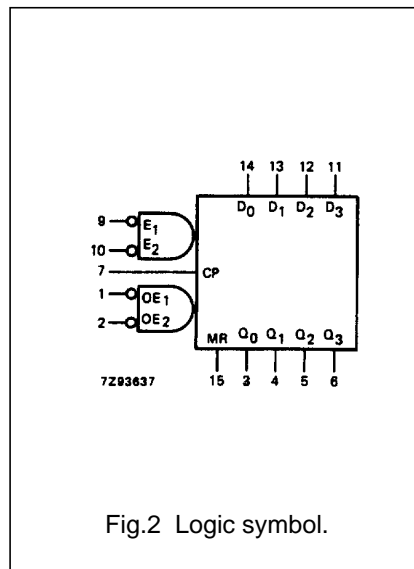
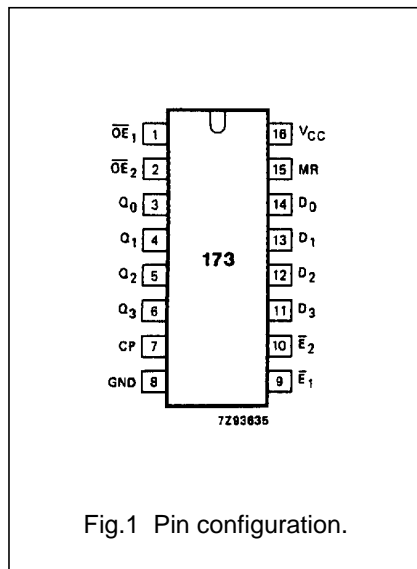

Quad D-type flip-flop; positive-edge trigger; 3-state

74HC/HCT173

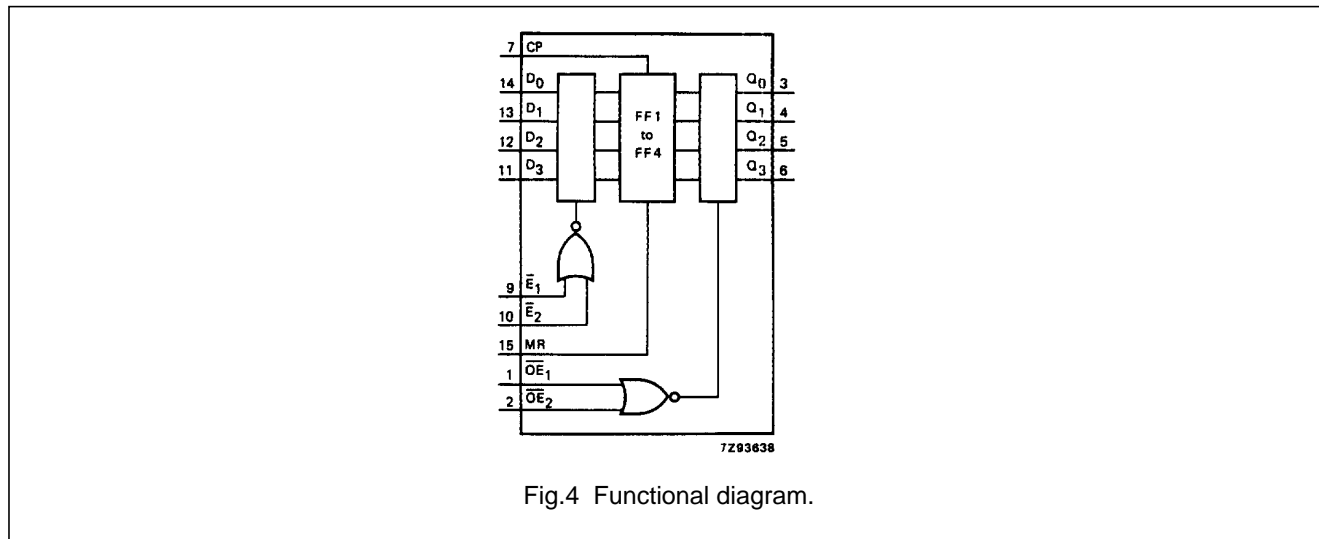

Fig.4 Functional diagram.

FUNCTION TABLE

REGISTER OPERATING MODES	INPUTS					OUTPUTS
	MR	CP	$\bar{E}_1$	$\bar{E}_2$	$D_n$	$Q_n$ (register)
reset (clear)	H	X	X	X	X	L
parallel load	L	$\uparrow$	l	l	l	L
	L	$\uparrow$	l	l	h	H
hold (no change)	L	X	h	X	X	$q_n$
	L	X	X	h	X	$q_n$

3-STATE BUFFER OPERATING MODES	INPUTS			OUTPUTS			
	$Q_n$ (register)	$\overline{OE}_1$	$\overline{OE}_2$	$Q_0$	$Q_1$	$Q_2$	$Q_3$
read	L	L	L	L	L	L	L
	H	L	L	H	H	H	H
disabled	X	H	X	Z	Z	Z	Z
	X	X	H	Z	Z	Z	Z

Notes

- H = HIGH voltage level  
 h = HIGH voltage level one set-up time prior to the LOW-to-HIGH CP transition  
 L = LOW voltage level  
 l = LOW voltage level one set-up time prior to the LOW-to-HIGH CP transition  
 q = lower case letters indicate the state of the referenced input (or output)  
 one set-up time prior to the LOW-to-HIGH CP transition  
 X = don't care  
 Z = high impedance OFF-state  
 $\uparrow$  = LOW-to-HIGH CP transition

Quad D-type flip-flop; positive-edge trigger; 3-state

74HC/HCT173

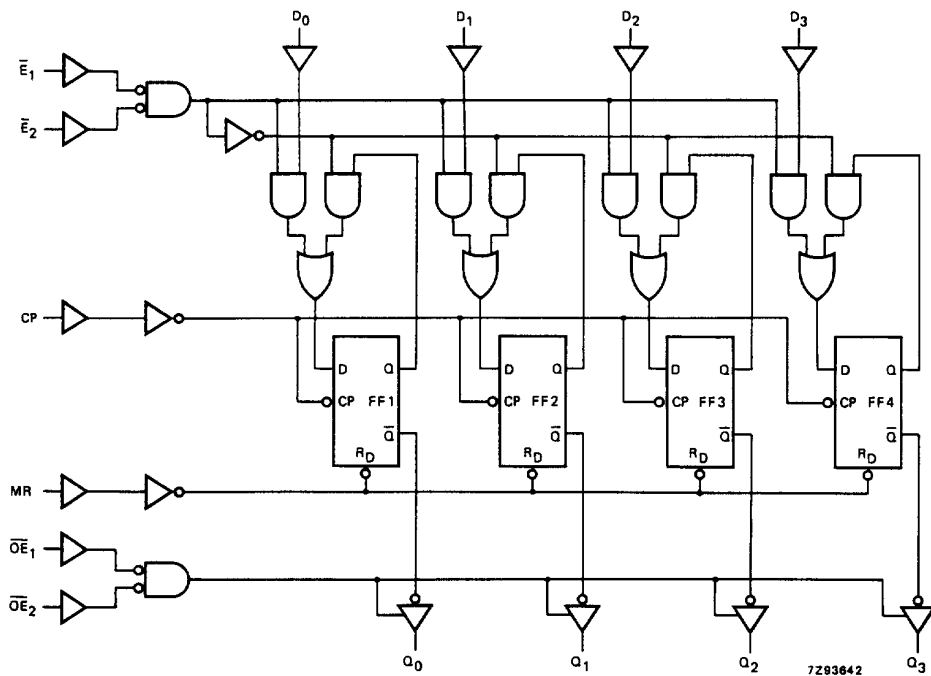

Fig.5 Logic diagram.

## Quad D-type flip-flop; positive-edge trigger; 3-state

## 74HC/HCT173

**DC CHARACTERISTICS FOR 74HC**

For the DC characteristics see *"74HC/HCT/HCU/HCMOS Logic Family Specifications"*.

Output capability: bus driver

I<sub>CC</sub> category: MSI

**AC CHARACTERISTICS FOR 74HC**

GND = 0 V; t<sub>r</sub> = t<sub>f</sub> = 6 ns; C<sub>L</sub> = 50 pF

SYMBOL	PARAMETER	T <sub>amb</sub> (°C)						UNIT	TEST CONDITIONS		
		74HC							V <sub>CC</sub> (V)	WAVEFORMS	
		+25			-40 to +85		-40 to +125				
		min.	typ.	max.	min.	max.	min.				max.
t <sub>PHL</sub> / t <sub>PLH</sub>	propagation delay CP to Q <sub>n</sub>		55 20 16	175 35 30		220 44 37		265 53 45	ns	2.0 4.5 6.0	Fig.6
t <sub>PHL</sub>	propagation delay MR to Q <sub>n</sub>		44 16 13	150 30 26		190 38 33		225 45 38	ns	2.0 4.5 6.0	Fig.7
t <sub>PZH</sub> / t <sub>PZL</sub>	3-state output enable time $\overline{OE}_n$ to Q <sub>n</sub>		52 19 15	150 30 26		190 38 33		225 45 38	ns	2.0 4.5 6.0	Fig.8
t <sub>PHZ</sub> / t <sub>PLZ</sub>	3-state output disable time $\overline{OE}_n$ to Q <sub>n</sub>		52 19 15	150 30 26		190 38 33		225 45 38	ns	2.0 4.5 6.0	Fig.8
t <sub>THL</sub> / t <sub>TLH</sub>	output transition time		14 5 4	60 12 10		75 15 13		90 18 15	ns	2.0 4.5 6.0	Fig.6
t <sub>w</sub>	clock pulse width HIGH or LOW	80 16 14	14 5 4		100 20 17		120 24 20		ns	2.0 4.5 6.0	Fig.6
t <sub>w</sub>	master reset pulse width; HIGH	80 16 14	14 5 4		100 20 17		120 24 20		ns	2.0 4.5 6.0	Fig.7
t <sub>rem</sub>	removal time MR to CP	60 12 10	-8 -3 -2		75 15 13		90 18 15		ns	2.0 4.5 6.0	Fig.7
t <sub>su</sub>	set-up time $\overline{E}_n$ to CP	100 20 17	33 12 10		125 25 21		150 30 26		ns	2.0 4.5 6.0	Fig.9
t <sub>su</sub>	set-up time D <sub>n</sub> to CP	60 12 10	17 6 5		75 15 13		90 18 15		ns	2.0 4.5 6.0	Fig.9

## Quad D-type flip-flop; positive-edge trigger; 3-state

## 74HC/HCT173

SYMBOL	PARAMETER	T <sub>amb</sub> (°C)							UNIT	TEST CONDITIONS	
		74HC								V <sub>CC</sub> (V)	WAVEFORMS
		+25			-40 to +85		-40 to +125				
		min.	typ.	max.	min.	max.	min.	max.			
t <sub>h</sub>	hold time E <sub>n</sub> to CP	0	-17		0		0		ns	2.0	Fig.9
		0	-6		0		0			4.5	
		0	-5		0		0			6.0	
t <sub>h</sub>	hold time D <sub>n</sub> to CP	1	-11		1		1		ns	2.0	Fig.9
		1	-4		1		1			4.5	
		1	-3		1		1			6.0	
f <sub>max</sub>	maximum clock pulse frequency	6.0	26		4.8		4.0		MHz	2.0	Fig.6
		30	80		24		20			4.5	
		35	95		28		24			6.0	

## Quad D-type flip-flop; positive-edge trigger; 3-state

74HC/HCT173

**DC CHARACTERISTICS FOR 74HCT**

For the DC characteristics see *"74HC/HCT/HCU/HCMOS Logic Family Specifications"*.

Output capability: bus driver

I<sub>CC</sub> category: MSI

**Note to HCT types**

The value of additional quiescent supply current ( $\Delta I_{CC}$ ) for a unit load of 1 is given in the family specifications. To determine  $\Delta I_{CC}$  per input, multiply this value by the unit load coefficient shown in the table below.

INPUT	UNIT LOAD COEFFICIENT
$\overline{OE}_1, \overline{OE}_2$	0.50
MR	0.60
$\overline{E}_1, \overline{E}_2$	0.40
D <sub>n</sub>	0.25
CP	1.00



## Quad D-type flip-flop; positive-edge trigger; 3-state

## 74HC/HCT173

**AC CHARACTERISTICS FOR 74HCT**GND = 0 V;  $t_r = t_f = 6$  ns;  $C_L = 50$  pF

SYMBOL	PARAMETER	T <sub>amb</sub> (°C)						UNIT	TEST CONDITIONS		
		74HCT							V <sub>CC</sub> (V)	WAVEFORMS	
		+25			-40 to +85		-40 to +125				
		min.	typ.	max.	min.	max.	min.				max.
t <sub>PHL</sub> / t <sub>PLH</sub>	propagation delay CP to Q <sub>n</sub>		20	40		50		60	ns	4.5	Fig.6
t <sub>PHL</sub>	propagation delay MR to Q <sub>n</sub>		20	37		46		56	ns	4.5	Fig.7
t <sub>PZH</sub> / t <sub>PZL</sub>	3-state output enable time $\overline{OE}_n$ to Q <sub>n</sub>		20	35		44		53	ns	4.5	Fig.8
t <sub>PHZ</sub> / t <sub>PLZ</sub>	3-state output disable time $\overline{OE}_n$ to Q <sub>n</sub>		19	30		38		45	ns	4.5	Fig.8
t <sub>THL</sub> / t <sub>TLH</sub>	output transition time		5	12		15		19	ns	4.5	Fig.6
t <sub>W</sub>	clock pulse width HIGH or LOW	16	7		20		24		ns	4.5	Fig.6
t <sub>W</sub>	master reset pulse width; HIGH	15	6		19		22		ns	4.5	Fig.7
t <sub>rem</sub>	removal time MR to CP	12	-2		15		18		ns	4.5	Fig.7
t <sub>su</sub>	set-up time $\overline{E}_n$ to CP	22	13		28		33		ns	4.5	Fig.9
t <sub>su</sub>	set-up time D <sub>n</sub> to CP	12	7		15		18		ns	4.5	Fig.9
t <sub>h</sub>	hold time $\overline{E}_n$ to CP	0	-6		0		0		ns	4.5	Fig.9
t <sub>h</sub>	hold time D <sub>n</sub> to CP	0	-3		0		0		ns	4.5	Fig.9
f <sub>max</sub>	maximum clock pulse frequency	30	80		24		20		MHz	4.5	Fig.6

Quad D-type flip-flop; positive-edge trigger;  
3-state

74HC/HCT173

AC WAVEFORMS

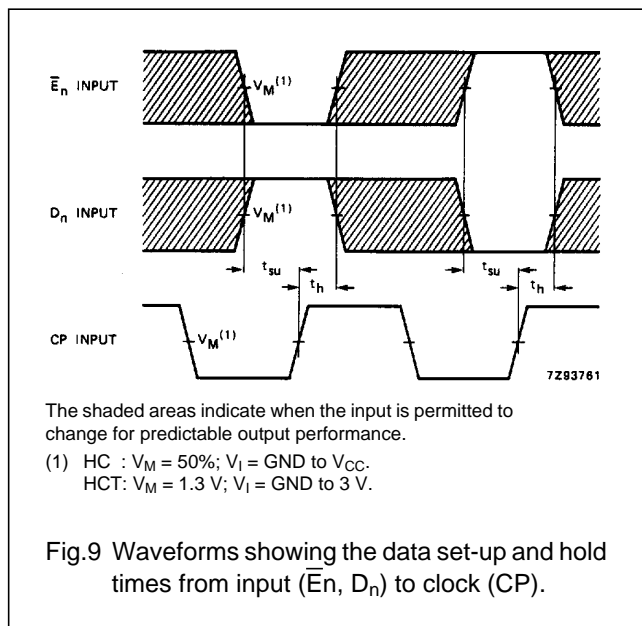
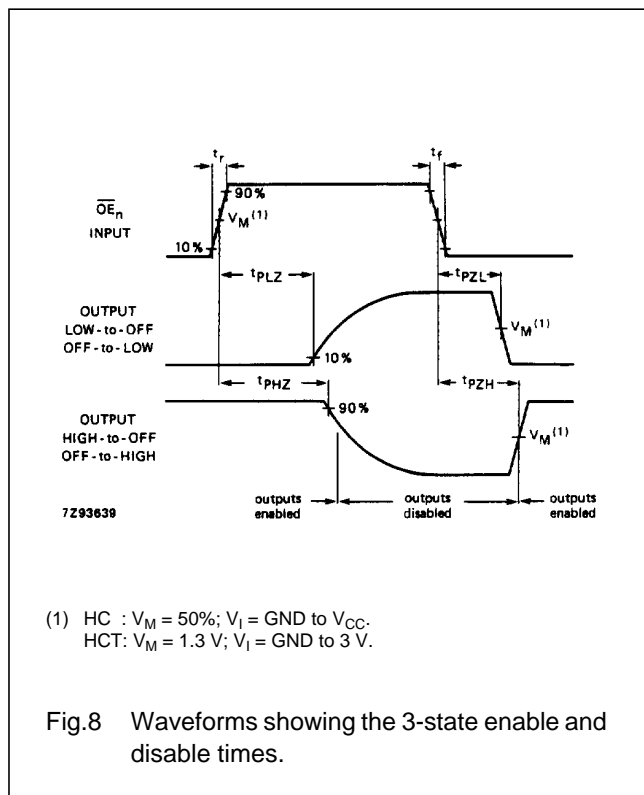
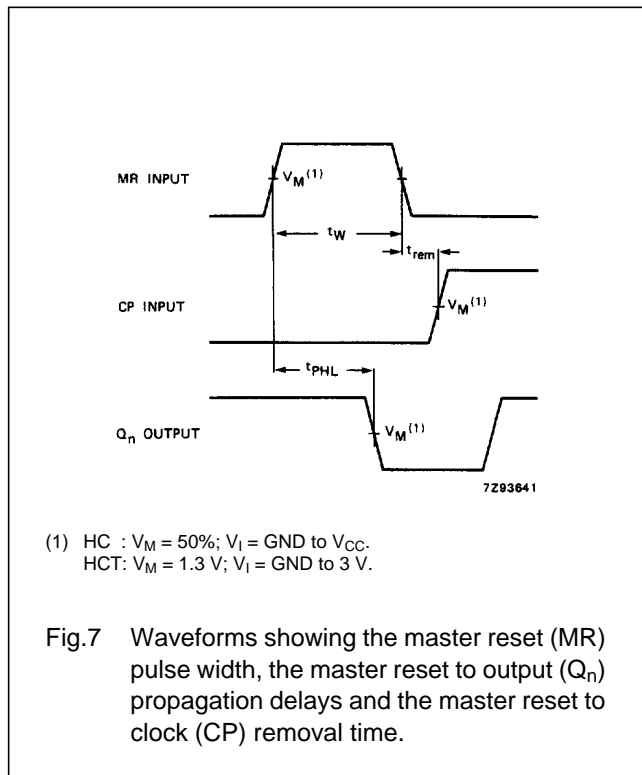
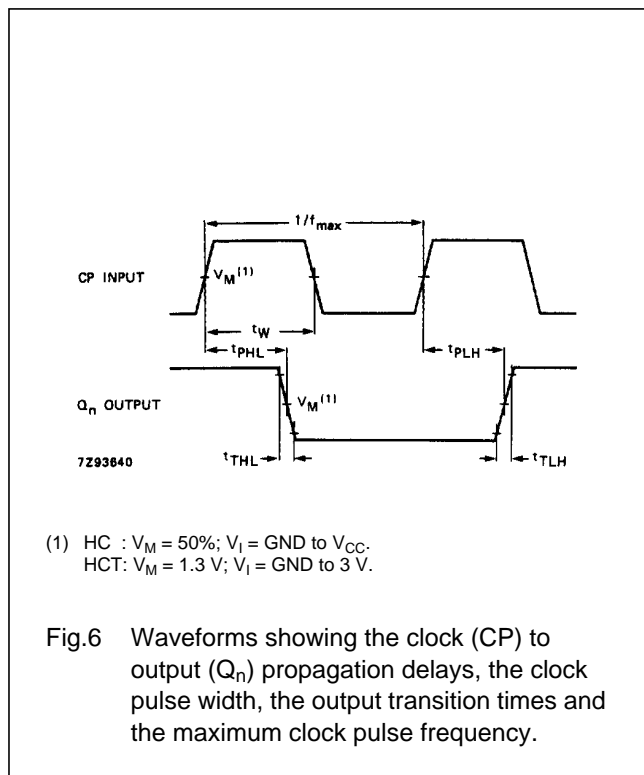

PACKAGE OUTLINES

See "74HC/HCT/HCU/HCMOS Logic Package Outlines".

Information as of 2003-04-22

My.Semiconductors.COM.  
Your personal service from  
Philips Semiconductors.  
Please register now !

Use right mouse button to  
download datasheet

Download datasheet

Stay informed

# 74HC/HCT173; Quad D-type flip-flop; positive-edge trigger; 3-state

## Products

[MultiMarket](#)

[Semiconductors](#)

[Product Selector](#)

[Catalog by](#)

[Function](#)

[Catalog by](#)

[System](#)

[Cross-reference](#)

[Packages](#)

[End of Life](#)

[information](#)

[Distributors Go](#)

[Here!](#)

[Models](#)

[SoC solutions](#)

[General description](#) [Features](#) [Applications](#) [Datasheet](#)

[Block diagram](#) [Buy online](#) [Support & tools](#) [Email/translate](#)

[Products & packages](#) [Parametrics](#) [Similar products](#)

## General description

The 74HC/HCT173 are high-speed Si-gate CMOS devices and are pin compatible with low power Schottky TTL (LSTTL). They are specified in compliance with JEDEC standard no. 7A.

The 74HC/HCT173 are 4-bit parallel load registers with clock enable control, 3-state buffered outputs ( $Q_0$  to  $Q_3$ ) and master reset (MR).

When the two data enable inputs ( $E_1$  and  $E_2$ ) are LOW, the data on the  $D_n$  inputs is loaded into the register synchronously with the LOW-to-HIGH clock (CP) transition. When one or both  $E_n$  inputs are HIGH one set-up time prior to the LOW-to-HIGH clock transition, the register will retain the previous data. Data inputs and clock enable inputs are fully edge-triggered and must be stable only one set-up time prior to the LOW-to-HIGH clock transition.

The master reset input (MR) is an active HIGH asynchronous input. When MR is HIGH, all four flip-flops are reset (cleared) independently of any other input condition.

The 3-state output buffers are controlled by a 2-input NOR gate. When both output enable inputs ( $OE_1$  and  $OE_2$ ) are LOW, the data in the register is presented to the  $Q_n$  outputs. When one or both  $OE_n$  inputs are HIGH, the outputs are forced to a high impedance OFF-state. The 3-state output buffers are completely independent of the register operation; the  $OE_n$  transition does not affect the clock and reset operations.

## Features



- Gated input enable for hold (do nothing) mode
- Gated output enable control
- Edge-triggered D-type register
- Asynchronous master reset
- Output capability: bus driver
- $I_{CC}$  category: MSI

## □ Datasheet

<u>Type number</u>	<u>Title</u>	<u>Publication release date</u>	<u>Datasheet status</u>	<u>Page count</u>	<u>File size (kB)</u>	<u>Datasheet</u>
74HC/HCT173	Quad D-type flip-flop; positive-edge trigger; 3-state	12/1/1990	Product specification	10	65	 <a href="#">Download</a>

## Additional datasheet info

To complete the device datasheet with package and family information, also download the following PDF files. The "Logic Package Information" document is required to determine in which package(s) this device is available.

<u>Document</u>	<u>Description</u>
1  <a href="#">HCT FAMILY SPECIFICATIONS</a>	HC/T Family Specifications, The IC06 74HC/HCT/HCMOS Logic Family Specifications
2  <a href="#">HCT PACKAGE INFO</a>	HC/T Package Info, The IC06 74HC/HCT/HCMOS Logic Package Information
3  <a href="#">HCT PACKAGE OUTLINES</a>	HC/T Package Outlines, The IC06 74HC/HCT/HCMOS Logic Package Outlines

## □ Parametrics

<u>Type number</u>	<u>Package</u>	<u>Description</u>	<u>Propagation Delay(ns)</u>	<u>Voltage</u>	<u>No. of Pins</u>	<u>Power Dissipation Considerations</u>	<u>Logic Switching Levels</u>	<u>Output Drive Capability</u>
74HC173D	<a href="#">SOT109</a> (SO16)	Quad D-Type Flip-Flop; Postive-Edge Trigger; 3-State	15	5 Volts +	16	Low Power or Battery Applications	CMOS	Low
74HC173DB	<a href="#">SOT338-1</a> (SSOP16)	Quad D-Type Flip-Flop; Postive-Edge Trigger; 3-State	15	5 Volts +	16	Low Power or Battery Applications	CMOS	Low
74HC173N	<a href="#">SOT38-1</a> (DIP16)	Quad D-Type Flip-Flop; Postive-Edge Trigger; 3-State	15	5 Volts +	16	Low Power or Battery Applications	CMOS	Low

74HC173PW	<a href="#">SOT403-1</a> (TSSOP16)	Quad D-Type Flip-Flop; Positive-Edge Trigger; 3-State	15	5 Volts +	16	Low Power or Battery Applications	CMOS	Low
74HCT173D	<a href="#">SOT109</a> (SO16)	Quad D-Type Flip-Flop; Positive-Edge Trigger; TTL Enabled (3-State)	15	5 Volts +	16	Low Power or Battery Applications	TTL	Low
74HCT173DB	<a href="#">SOT338-1</a> (SSOP16)	Quad D-Type Flip-Flop; Positive-Edge Trigger; TTL Enabled (3-State)	15	5 Volts +	16	Low Power or Battery Applications	TTL	Low
74HCT173N	<a href="#">SOT38-1</a> (DIP16)	Quad D-Type Flip-Flop; Positive-Edge Trigger; TTL Enabled (3-State)	15	5 Volts +	16	Low Power or Battery Applications	TTL	Low

## ▣ Products, packages, availability and ordering

<u>Type number</u>	<u>North American type number</u>	<u>Ordering code (12NC)</u>	<u>Marking/Packing</u> <a href="#">Discretes packing info</a>	<u>Package</u>	<u>Device status</u>	<u>Buy online</u>
74HC173D	74HC173D	9337 145 60652	Standard Marking * Bulk Pack, CECC	<a href="#">SOT109</a> (SO16)	Full production	<a href="#">order this</a> <input type="checkbox"/>
	74HC173D-T	9337 145 60653	Standard Marking * Reel Pack, SMD, 13", CECC	<a href="#">SOT109</a> (SO16)	Full production	<a href="#">order this</a> <input type="checkbox"/>
74HC173DB	74HC173DB	9351 892 50112	Standard Marking * Bulk Pack	<a href="#">SOT338-1</a> (SSOP16)	Full production	<a href="#">order this</a> <input type="checkbox"/>
	74HC173DB-T	9351 892 50118	Standard Marking * Reel Pack, SMD, 13"	<a href="#">SOT338-1</a> (SSOP16)	Full production	<a href="#">order this</a> <input type="checkbox"/>
74HC173N	74HC173N	9336 694 20652	Standard Marking * Bulk Pack, CECC	<a href="#">SOT38-1</a> (DIP16)	Full production	<a href="#">order this</a> <input type="checkbox"/>

74HC173PW	74HC173PW	9351 895 50112	Standard Marking * Bulk Pack	<a href="#">SOT403-1</a> (TSSOP16)	Full production	<input type="text" value="order this"/> <input type="text" value="-"/>
	74HC173PW-T	9351 895 50118	Standard Marking * Reel Pack, SMD, 13"	<a href="#">SOT403-1</a> (TSSOP16)	Full production	<input type="text" value="order this"/> <input type="text" value="-"/>
74HCT173D	74HCT173D	9337 150 40652	Standard Marking * Bulk Pack, CECC	<a href="#">SOT109</a> (SO16)	Full production	<input type="text" value="order this"/> <input type="text" value="-"/>
	74HCT173D-T	9337 150 40653	Standard Marking * Reel Pack, SMD, 13", CECC	<a href="#">SOT109</a> (SO16)	Full production	<input type="text" value="order this"/> <input type="text" value="-"/>
74HCT173DB	74HCT173DB	9351 897 10112	Standard Marking * Bulk Pack	<a href="#">SOT338-1</a> (SSOP16)	Full production	<input type="text" value="order this"/> <input type="text" value="-"/>
	74HCT173DB-T	9351 897 10118	Standard Marking * Reel Pack, SMD, 13"	<a href="#">SOT338-1</a> (SSOP16)	Full production	<input type="text" value="order this"/> <input type="text" value="-"/>
74HCT173N	74HCT173N	9336 700 50652	Standard Marking * Bulk Pack, CECC	<a href="#">SOT38-1</a> (DIP16)	Full production	<input type="text" value="order this"/> <input type="text" value="-"/>

Products in the above table are all in production. Some variants are discontinued; [click here](#) for information on these variants.

## Similar products

[74HC/HCT173](#) links to the similar products page containing an overview of products that are similar in function or related to the type number(s) as listed on this page. The similar products page includes products from the same catalog tree(s), relevant selection guides and products from the same functional category.

## Support & tools

[HC/T Family Specifications, The IC06 74HC/HCT/HCMOS Logic Family Specifications](#)(date 01-Mar-98)

[HC/T User Guide](#)(date 01-Nov-97)

## Email/translate this product information

- [Email this product information.](#)
- Translate this product information page from English to:



The English language is the official language used at the [semiconductors.philips.com](#) website and webpages. All translations on this website are created through the use of [Google Language Tools](#) and are provided for convenience purposes only. No rights can be derived from any translation on this website.

[About this Web Site](#)

| Copyright © 2003 Koninklijke Philips N.V. All rights reserved. | [Privacy Policy](#) |

| Koninklijke Philips N.V. | Access to and use of this Web Site is subject to the following [Terms of Use](#). |