

PRODUCT NO
SEE TABLE

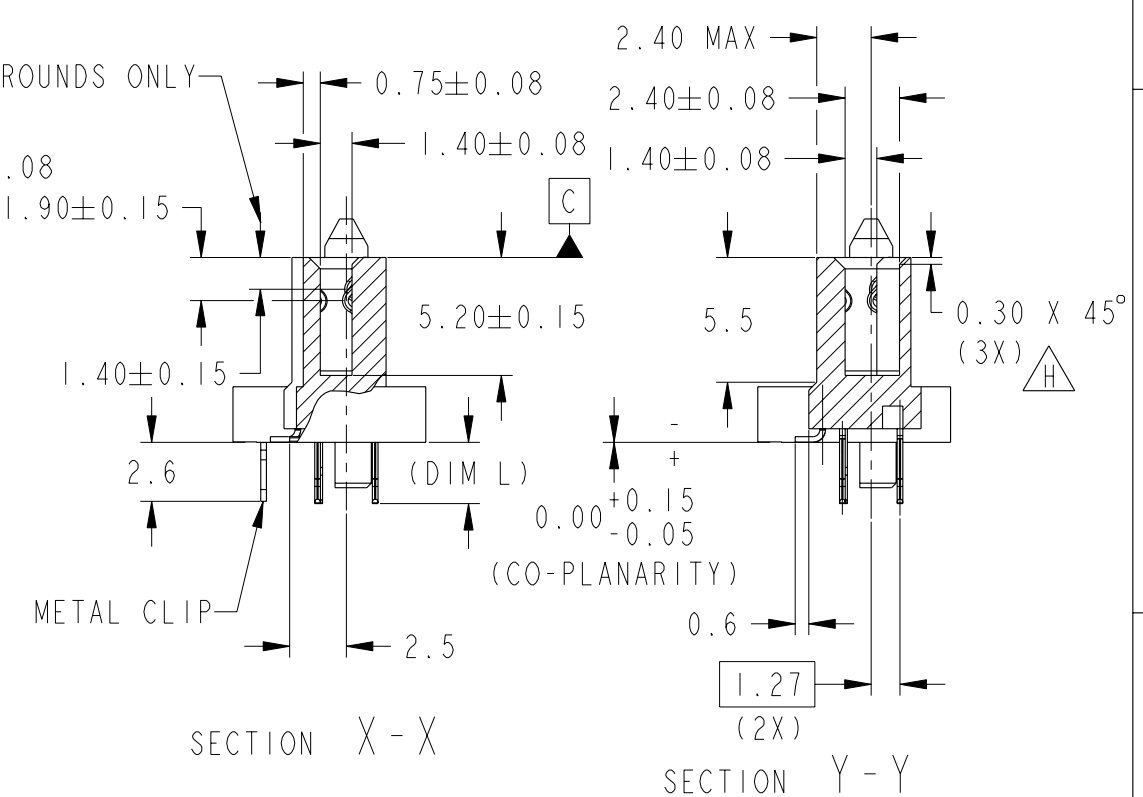
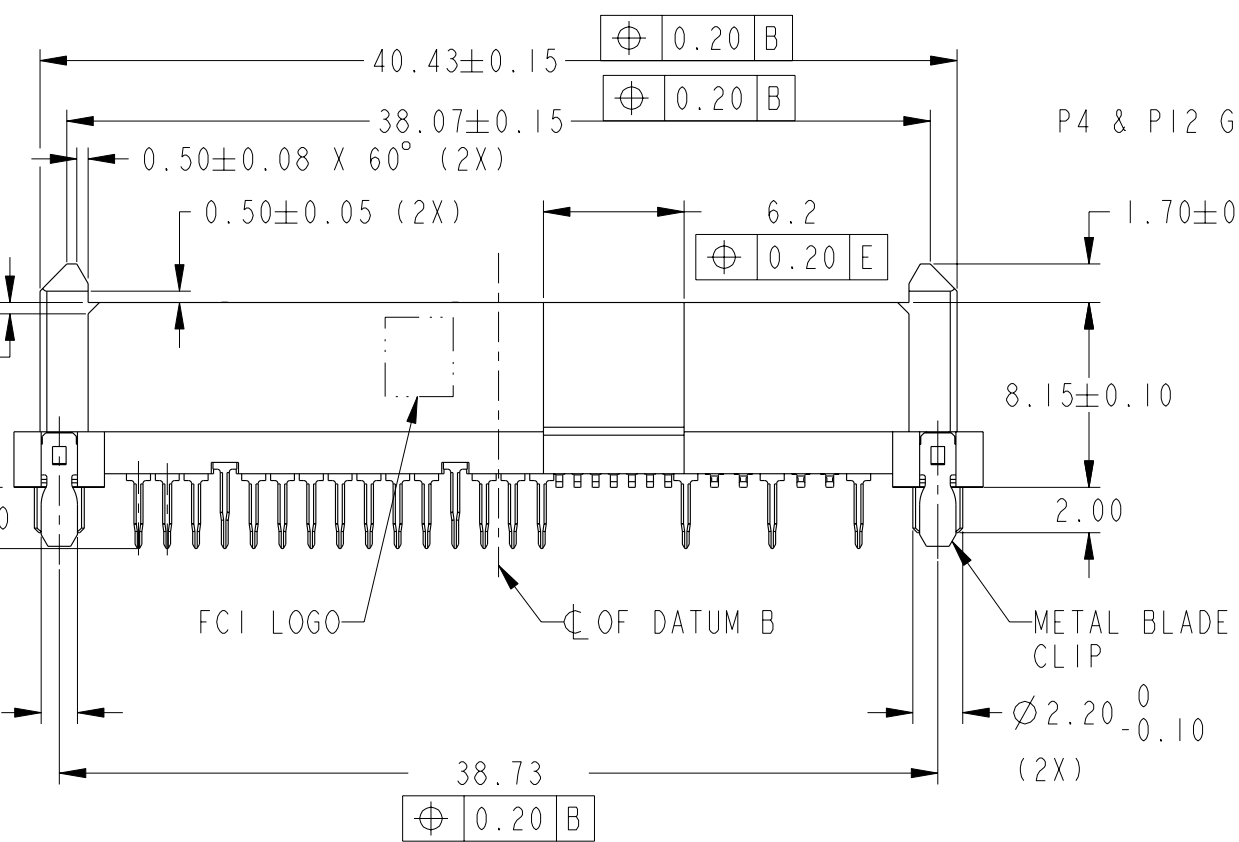
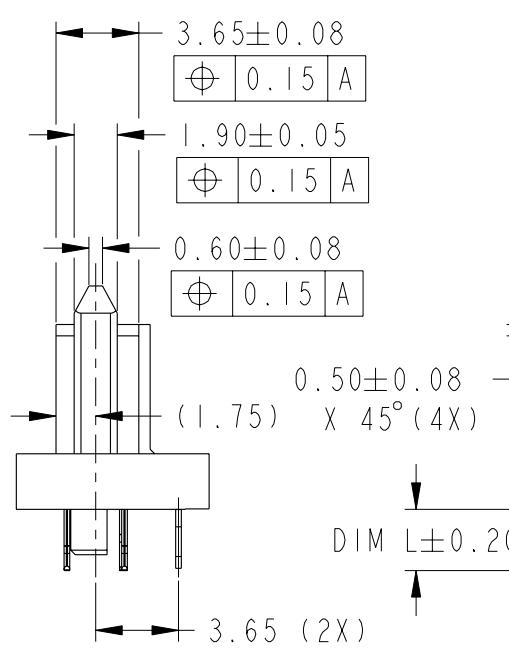
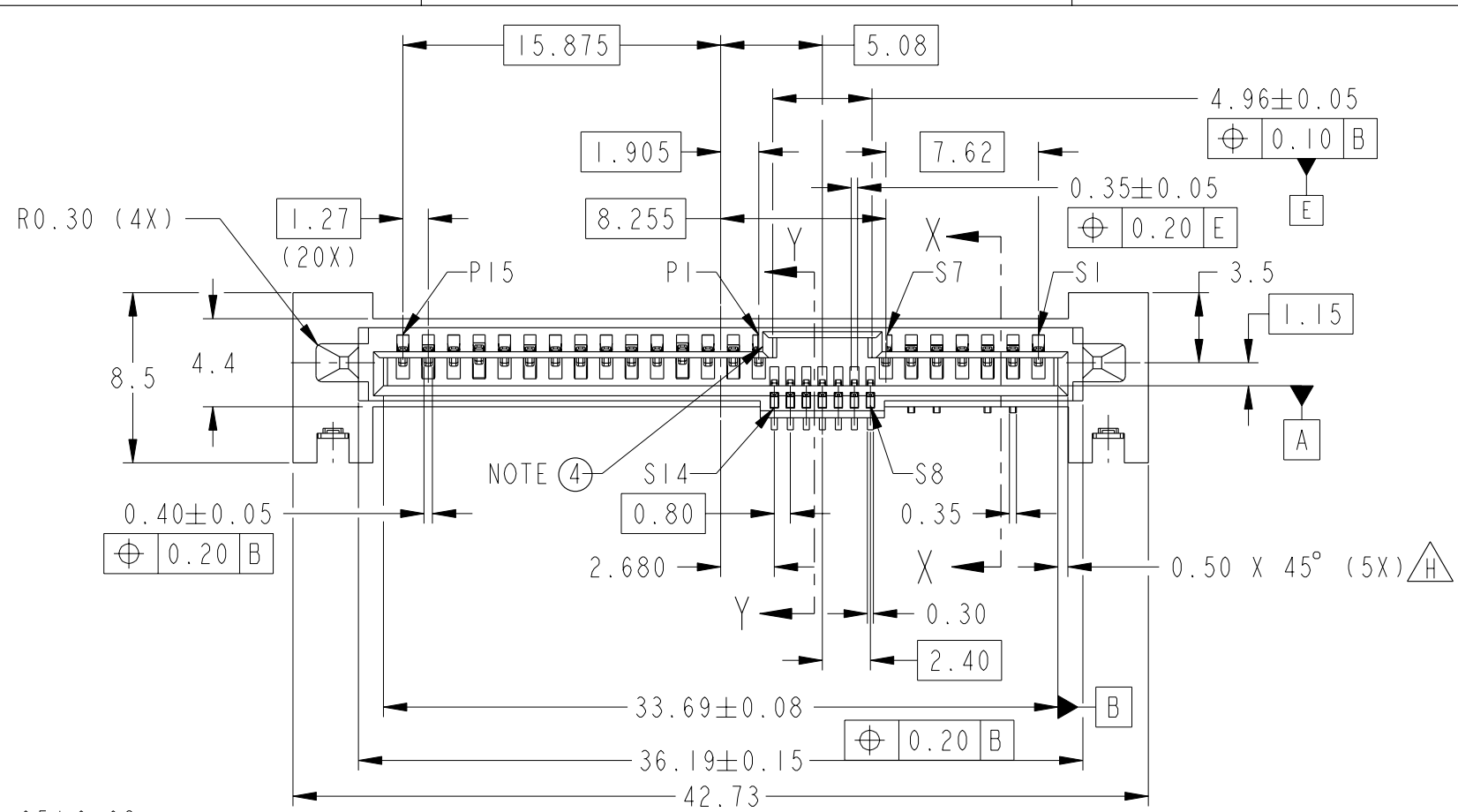

Copyright FCI.

spec ref	-	dr	GL LOO	2005-02-23	projection	MM	size	A3	scale	3:1
tolerance std	ISO 406 ISO 1101	eng	GL LOO	2005-02-23			ecn no	S10-0228	rel level	-
TOLERANCES UNLESS OTHERWISE SPECIFIED		chr	GL LOO	2010-10-28						
surface	ISO 1302	appr	JOEY NG	2010-10-28	SAS RECEPTACLE WIDE BASE HYBRID TYPE ASSY		dwg no	10036876	rev	H
					cat. no.	-	Product - Customer Drw	sheet 1 of 3		

PRODUCT NO	DIM L (SOLDER TAIL)	PICK-UP CAP	RECOMMENDED P.C. BOARD THICKNESS	TYPE OF CLIP	PACKAGING
10036876-003LF	2.70	NO	1.57mm (0.062") / 2.36mm (0.093")	METAL BLADE	TRAY
10036876-003CLF		YES			TAPE & REEL
10036876-003C-TRLF		YES			
10036876-013LF	3.70	NO	2.36mm (0.093")	METAL BLADE	TRAY
10036876-013CLF		YES			TAPE & REEL
10036876-013C-TRLF		YES			
10036876-004LF	2.70	NO	2.36mm (0.093")	FORK LOCK	TRAY
10036876-014LF	3.70	NO	2.36mm (0.093")	FORK LOCK	TRAY

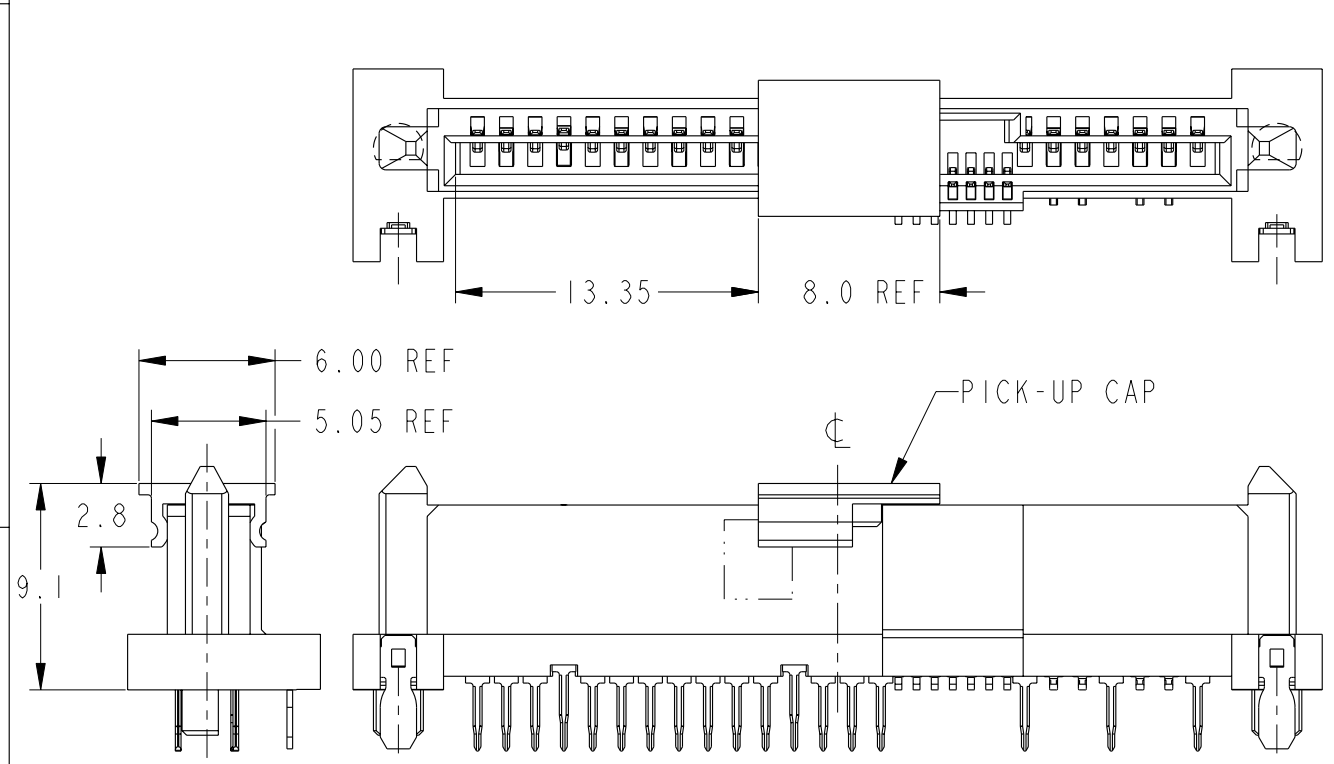

PART WITH PICK-UP CAP, SEE NOTE ⑤

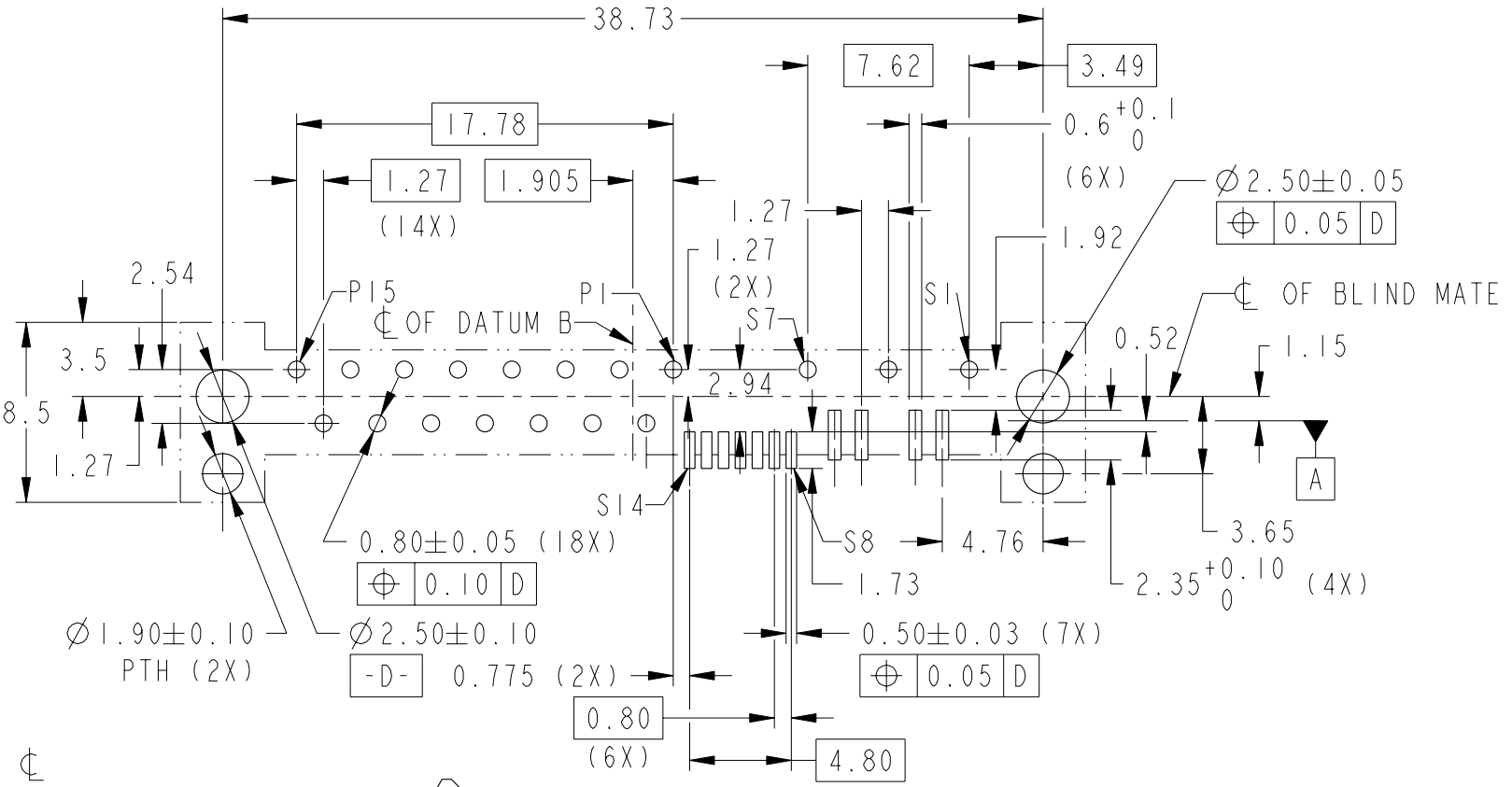

RECOMMENDED PCB LAYOUT

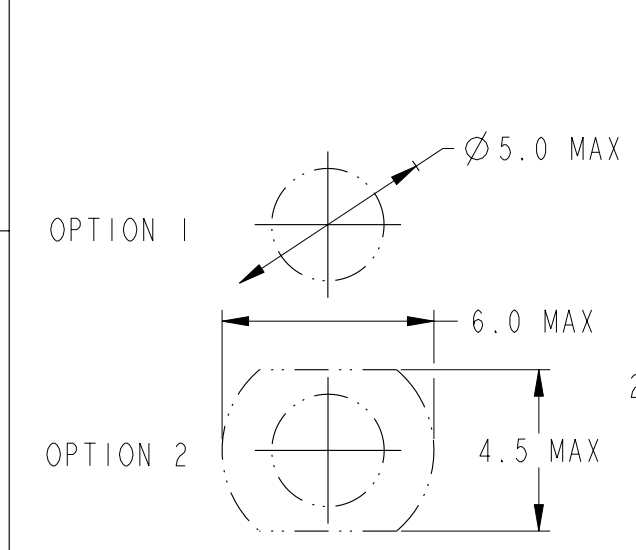

RECOMMENDED SUCTION HEAD SIZE

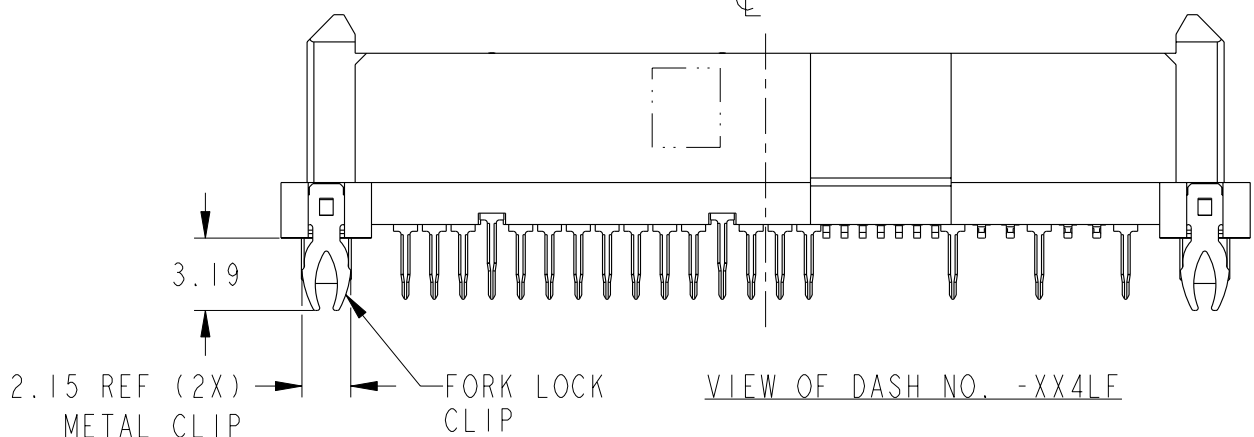

VIEW OF DASH NO. -XX4LF

spec ref	-	dr	GL LOO	2005-02-23	projection	MM	size	A3	scale	3:1
tolerance std	ISO 406 ISO 1101	eng	GL LOO	2005-02-23			ecn no	S10-0228	rel level	-
TOLERANCES UNLESS OTHERWISE SPECIFIED		chr	GL LOO	2010-10-28						
surface	ISO 1302	appr	JOEY NG	2010-10-28			rel level	-		
	linear	0.X	±-				dwg no	10036876	rev	H
		0.XX	±0.20				cat. no.	-	Product - Customer Drw	sheet 2 of 3
	angular	0°	±2°							

Copyright FCI.





NOTES:

1. MATERIAL:
 - 1) HOUSING : HIGH TEMP TERMOPLASTIC, UL 94V-0
COLOUR : BLACK
 - 2) TERMINAL : COPPER ALLOY
 - 3) HOLD DOWN : COPPER ALLOY
2. FINISH :
 - 1) TERMINAL : 30µ" Au PLATING (CONTACT POINT) OVER 50µ" NICKEL
 - 2) SOLDER TAIL : 50µ" MIN Sn OVER 50µ" NICKEL
 - 3) HOLD DOWN : 50µ" MIN Sn OVER 50µ" NICKEL
3. -
4. PER SFF REV 1.3
- ⑤ PART WITH PICK-UP CAP, P/N XXXXXXXX-XXXC LF
- ⑥ THE STD PACKAGING IS IN TRAY
7. FOR TAPE & REEL PACKAGING, SUFFIX "-TR" ADDED.
P/N XXXXXXXX-XXXC-TR LF
8. THE HOUSING WILL WITHSTAND EXPOSURE TO 260°C PEAK TEMPERATURE FOR 10 SECONDS IN A CONVECTION, INFRA-RED OR VAPOR PHASE REFLOW OVEN
- ⑨ THIS PRODUCT MEETS EUROPEAN UNION DIRECTIVES AND OTHER COUNTRY REGULATIONS AS DESCRIBED IN GS-22-008
- ⑩ PART NUMBERS ENDING IN "LF" MEANS FOR NOTE 8 LEAD FREE IDENTIFICATION
 - (i) ~~XXXXXXXX-XXXLF IS EQUIVALENT TO PREVIOUS P/N XXXXXXXX-XXX-~~
 - (ii) ~~XXXXXXXX-XXXCLF IS EQUIVALENT TO PREVIOUS P/N XXXXXXXX-XXXC-~~
11. A  SYMBOL WILL BE NEXT TO ANY DIMENSION, VIEW, OR NOTE WHICH HAS BEEN MODIFIED WITH THE CURRENT DRAWING REVISION.

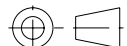
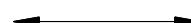

Copyright FCI.

spec ref -		dr	GL LOO	2005-02-23	projection 	MM 	size	A3	scale	3:1	
tolerance std ISO 406 ISO 1101		TOLERANCES UNLESS OTHERWISE SPECIFIED					eng	GL LOO	2005-02-23	ecn no S10-0228	
		chr	GL LOO	2010-10-28			appr	JOEY NG	2010-10-28	product family	S-ATA
surface 	linear	0.X	± -		SAS RECEPTACLE WIDE BASE HYBRID TYPE ASSY			dwg no	10036876		rev H
		0.XX	±0.20								
		0.XXX	± -								
ISO 1302	angular	0°	±2°	www.fci.com	cat. no.	-	Product - Customer Drw			sheet 3 of 3	