



USBF TV (USB-A)

USB Connection System for Harsh Environment



With USB Field, you can insert a standard USB 2.0 cordset into a metallic plug which will protect it from shocks, dust and fluids.

No hazardous on-field cabling and grounding!

This metallic plug is connected into a receptacle, using a Tri Start Thread coupling mechanism (MIL-DTL-38999 series III type) with anti-decoupling device for high vibrations.

Applications

- Embedded Computers
- Data Acquisition and transmission in harsh environment
- Railways
- Battelfield Communication Systems
- Navy Systems

Data Transmission

USB Specification 2.0
Data Rate: Up to 480 Mb/s for High Speed USB

MAIN CHARACTERISTICS

- Sealed against fluids and dusts (IP68)
- Shock, Vibration and Traction resistant
- No cabling operation in field and no tools required
- Improved EMI protection
- Tri Start Thread coupling mechanism (MIL-DTL-38999 series III type) with anti-decoupling device
- 2 mechanical Coding / Polarization possibilities by the user (receptacle insert rotation)
- USBF TV plug retention in the receptacle: 100 N in the axis
- Mating cycles: 500 to 1500

Environmental Protection

- Sealing (when mated): IP68 (Temporary immersion)
- Salt Spray: 48 h with Nickel plating
> 500 h with Olive Drab Cadmium
1000 h with marine bronze shell
- Fire Retardant / Low Smoke: UL94 V0 and NF F 16 101 & 16 102
- Vibrations: 10 – 500 Hz, 10 g, 3 axes: no discontinuity > 1micro s
- Shocks: IK06: weight of 250 g drop from 40 cm [15.75 in] onto connectors (mated pair)
- Humidity: 21 days, 43°C, 98% humidity
- Temperature Range: - 40°C / +85°C

Part Number Code

Series USB Field TV	USBF TV	2	1	G
Shell Type				
6:	Plug			
2:	Square flange receptacle			
2PE:	Square flange receptacle with metal backshell (type 1) & with metal backshell + plastic gland (type 2)			
2PEM:	Square flange receptacle with backshell + metal gland (only for back termination type 2 = Solder)			
7:	Jam nut receptacle			
7PE:	Jam nut receptacle with metal backshell (type 1) & with metal backshell + plastic gland (type 2)			
7PEM:	Jam nut receptacle with backshell + metal gland (only for back termination type 2 = Solder)			
Back Terminations (Receptacles only)				
1:	Female USB-A			
2:	Solder (4 tinned holes)			
Shells Material & Finish				
N:	Aluminium shell - Nickel plating - ROHS compliant			
G:	Aluminium shell - Olive Drab Cadmium plating			
BZ:	Marine bronze shell - ROHS compliant			

- Examples:
- Olive Drab Cadmium Plug: USBF TV 6G
 - Olive Drab Cadmium Square Flange Receptacle, USB-A back terminat°: USBF TV 21G
 - Olive Drab Cadmium Jam Nut Receptacle, USB-A receptacle back terminat°: USBF TV 71G
 - Nickel Jam Nut Receptacle, solder termination: USBF TV 72N

Amphenol USBF TV

Plug

- Shell type 6

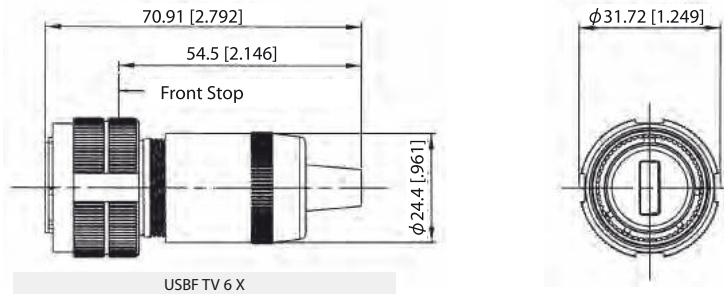

Receptacles

- Square flange receptacle
4 mounting holes: Shell type 2

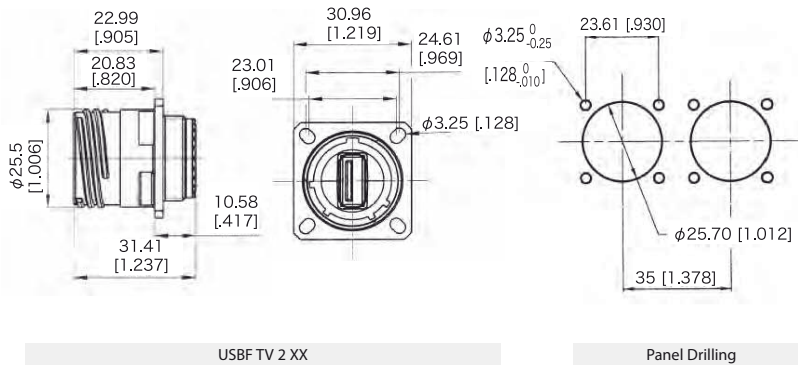

- Jam nut receptacle
Hexagonal Nut mounting:
Shell type 7

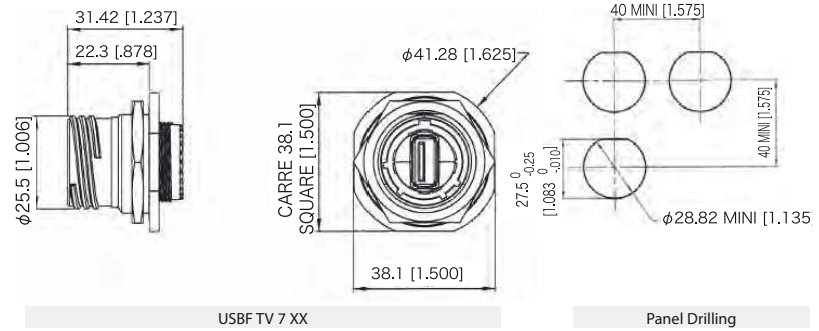

- Receptacles with backshell
Shell type 2PE and 7PE

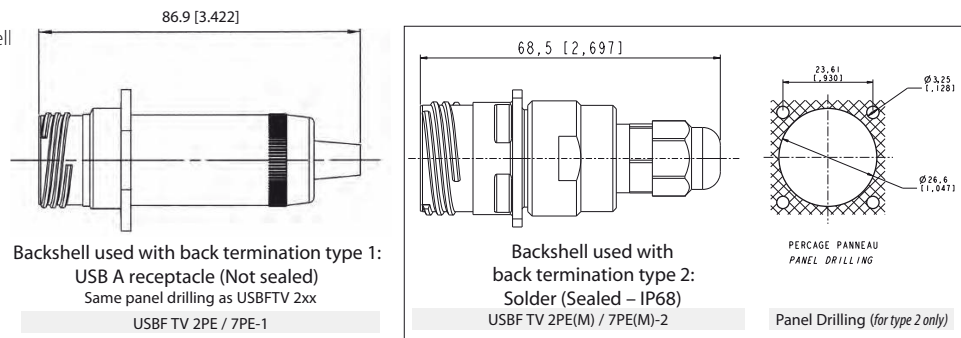

Back Terminations

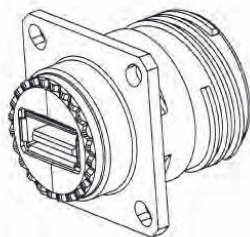

Type 1: Female USB-A

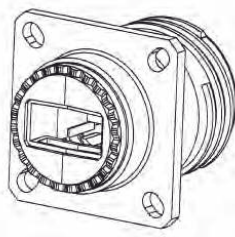

Type 2: Solder 4 Tinned holes to solder your cable

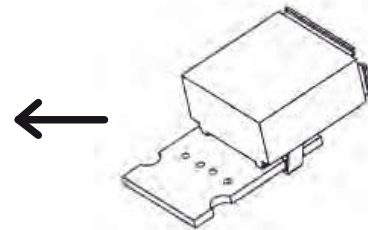

View of the PCB of the Type 2 version with 4 tinned holes for solder termination

Assembly Instructions

Can be used with most the USB cordset brands: No tools required!

Plug Assembly

1. Only if you need a full sealing (IP68): Install the white sticker around the plug, covering the 4 little holes of the overmolding
2. Insert the black O Ring around the front face of the USB A plug. This O Ring will ensure connection sealing
3. Insert the USB cordset into the metallic backshell
4. Insert the retention spacer laterally to the cable (this spacer is soft, in order to adapt to different shapes of overmolding) and slide the overmolding of the USB-A plug into this retention spacer
5. Insert the friction ring laterally to the cable
6. Choose the right coding (2 positions) and insert the USB-A plug into the protective plug. Note at this step, the main key is used for polarization.

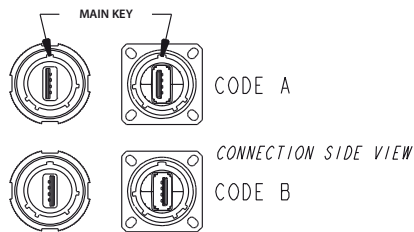

7. Screw the backshell on the plug body. A wrench can be necessary to fully tighten it, and the connection to the receptacle can help

IMPORTANT NOTE

The connection sealing is not done by the black retention spacer (which is slotted), but by the front face ORing (fig. 2)

Receptacle Assembly

Insert the USB module from the rear. Reference is main key. Beware to have a coding compatible with the coding you used for the plug: on front view, the white shapes in the USBs must be on the same side.

To remove the USB module, insert the removal tool **USBF ODE** from the front, and push back the module.

Accessories

■ Metallic Caps

	USBF TVC	2	G
Connector Type			
6:	Plug		
2:	Square Flange Receptacle		
7:	Jam Nut Receptacle		
Shells Material & Finish			
N:	Aluminium shell - Nickel - ROHS compliant		
G:	Aluminium shell - Olive Drab Cadmium		
BZ:	Marine bronze shell - ROHS compliant		

- Panel Gasket for square flange receptacle (Thickness: 0,8 mm [.031]): JE15



- Receptacle Insert removal tool: USBF ODE

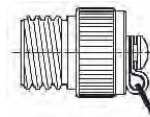

Plug Cap

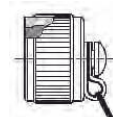

Receptacle Cap

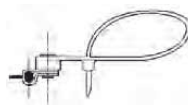

Plug Cap end

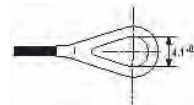

Square flange receptacle cap end

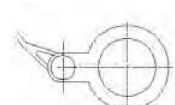

Jam Nut receptacle cap end