

THIS DRAWING IS UNPUBLISHED. RELEASED FOR PUBLICATION
 © COPYRIGHT BY TYCO ELECTRONICS CORPORATION. ALL RIGHTS RESERVED.

LOC	DIST	REVISIONS					
AD	00	P	LTR	DESCRIPTION	DATE	DWN	APVD
			E	REV PER EC 0S12-0458-02	10MAR03	BC	WM

- △1 0.000762 [.000030] MIN GOLD OVER 0.00127 [.000050] MIN NICKEL.
- △2 0.00508 [.000200] MIN SILVER OVER 0.00254 [.000100] MIN COPPER.
- △3 0.00127 [.000050] MIN GOLD OVER 0.00127-0.00254 [.000050-.000100] NICKEL.
- △4 0.00127-0.00254 [.000050-.000100] NICKEL.

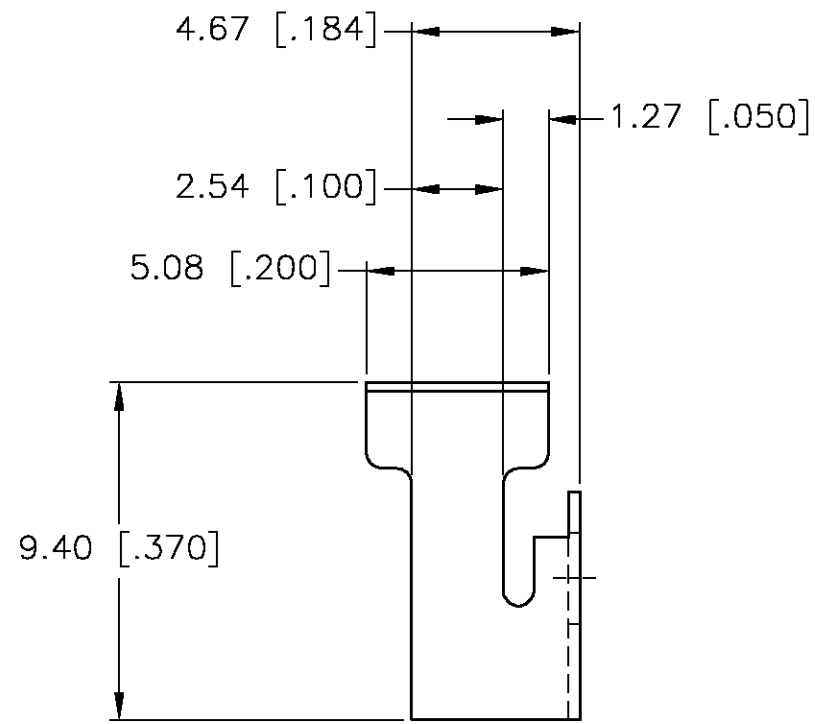
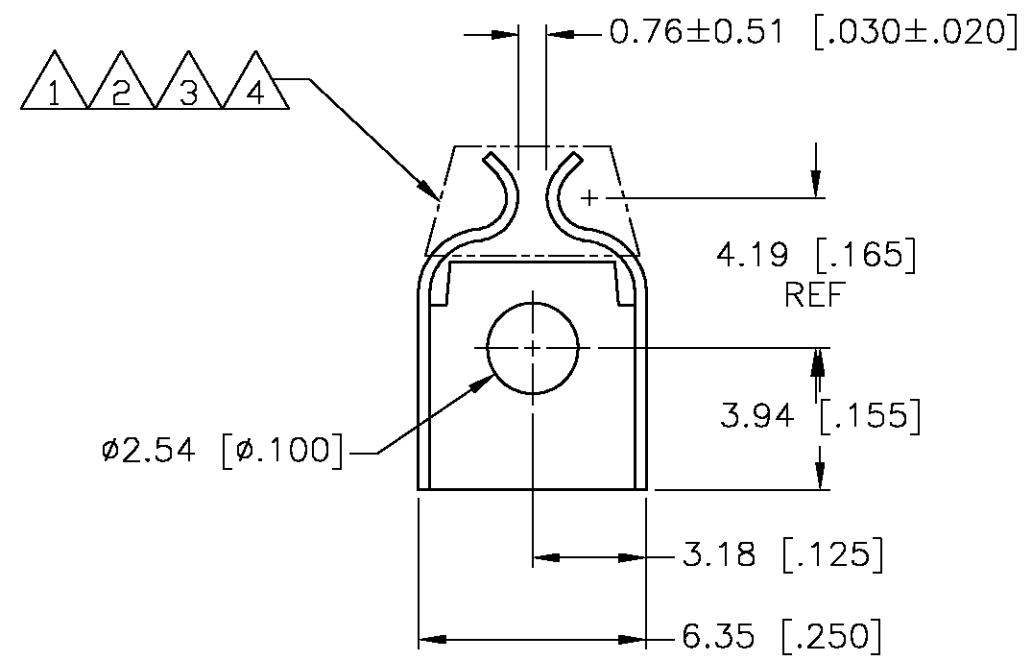

	△4	532900-8
OBSOLETE	△3 L.P.	532900-7
	△3	532900-6
OBSOLETE	△2	532900-5
	△1	532900-3
	FINISH	PART NO

THIS DRAWING IS A CONTROLLED DOCUMENT.		DWN D.EVANS	10-27-82	tyco Electronics		Tyco Electronics Corporation Harrisburg, PA, 17105-3608	
DIMENSIONS: MM [INCHES]		CHK -	-	NAME POWER CONTACT, HDI, ESD			
TOLERANCES UNLESS OTHERWISE SPECIFIED:		APVD -	-	PRODUCT SPEC -			
0 PLC ± -		APPLICATION SPEC -		SIZE A3	CAGE CODE 00779	DRAWING NO 532900	RESTRICTED TO -
1 PLC ± -		WEIGHT -		CUSTOMER DRAWING		SCALE 10:1	SHEET 1 OF 1
2 PLC ± -		MATERIAL PHOS BRONZE		FINISH SEE TABLE		REV E	
3 PLC ± -							
4 PLC ± -							
ANGLES ± -							