

H
G
F
E
D
C
B
A

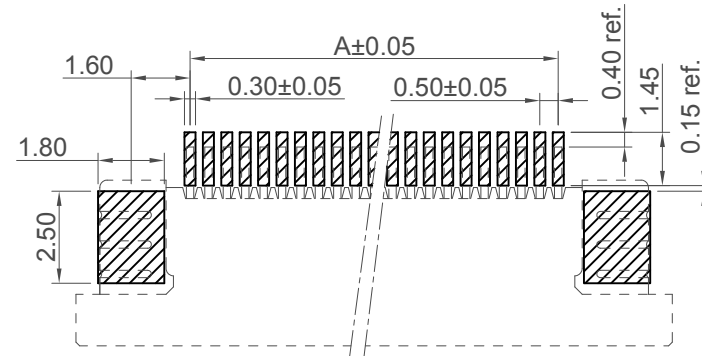

Recommended PCB Layout
as viewed from component side

▨ Solder Area □ Component Outline

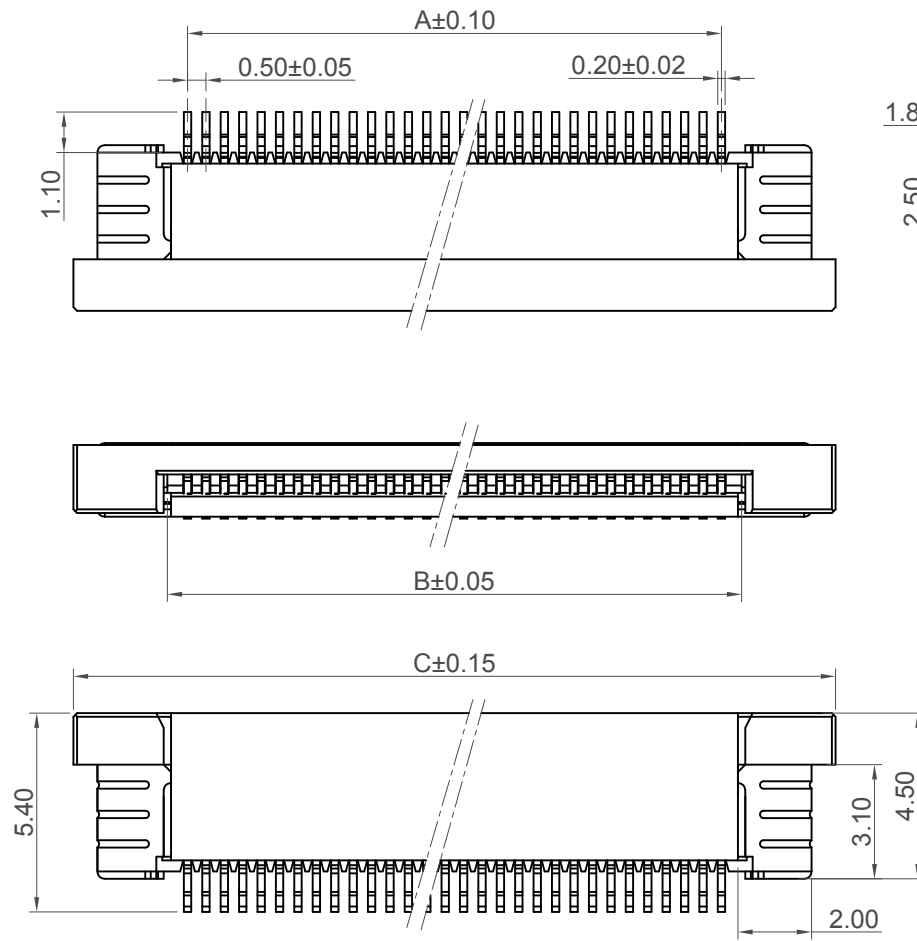
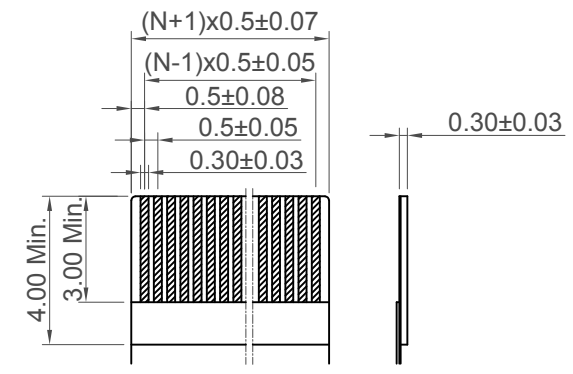
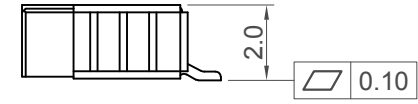
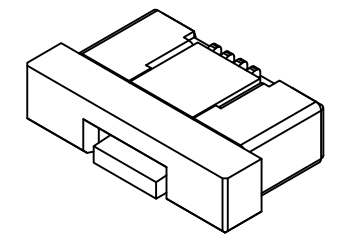

Recommended FFC/FPC Dimensions
Thickness 0.30±0.03

No. of Contacts	Dimensions		
	A	B	C
* 4	1.50	2.60	7.7
* 5	2.00	3.10	8.2
* 6	2.50	3.60	8.7
* 7	3.00	4.10	9.2
* 8	3.50	4.60	9.7
* 9	4.00	5.10	10.2
* 10	4.50	5.60	10.7
* 11	5.00	6.10	11.2
* 12	5.50	6.60	11.7
* 13	6.00	7.10	12.2
* 14	6.50	7.60	12.7
* 15	7.00	8.10	13.2
* 16	7.50	8.60	13.7
* 17	8.00	9.10	14.2
* 18	8.50	9.60	14.7
19	9.00	10.10	15.2
* 20	9.50	10.60	15.7
* 21	10.00	11.10	16.2
* 22	10.50	11.60	16.7
* 23	11.00	12.10	17.2
* 24	11.50	12.60	17.7
* 25	12.00	13.10	18.2
* 26	12.50	13.60	18.7
* 27	13.00	14.10	19.2
* 28	13.50	14.60	19.7
29	14.00	15.10	20.2
* 30	14.50	15.60	20.7
31	15.00	16.10	21.2
* 32	15.50	16.60	21.7
33	16.00	17.10	22.2
* 34	16.50	17.60	22.7
* 35	17.00	18.10	23.2
* 36	17.50	18.60	23.7
37	18.00	19.10	24.2
* 38	18.50	19.60	24.7
39	19.00	20.10	25.2
* 40	19.50	20.60	25.7

Specification:

Material:

Housing Material: Thermoplastic, UL 94V-0
Actuator: Thermoplastic, UL 94V-0
Contact: Phosphor Bronze
Fitting Nail: Brass

Plating:

Contact: see ordering grid
Fitting Nail: Matte Tin Plating over Nickel

Electrical:

Voltage Rating (Max.): 50V AC/DC
Current Rating (Max.): 0.4A AC/DC
Dielectric Strength: 250V AC for 1 minute
Insulation Resistance: 50 MΩ Min.
Contact Resistance: 40 mΩ Max.

Mechanical & Environmental

Durability: 20 Cycles
Operating Temperature: -25°C to +85°C
Solder Profile:
Peak Temp 260°C (+0/-5°C) max. (5 seconds)

Ordering Grid

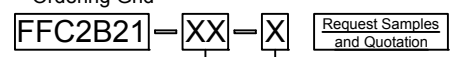

No. of Contacts
04 - 60
(see dimension table)

Contact Plating

T = Tin Plating over all (Standard)
G = Gold Flash over all

* = Tooled Parts
Please contact GCT for non-tooled parts

Part Number		Product Description	
FFC2B21		FPC 0.5mm Pitch Side Entry, Bottom Contact, SMT, Height=2.0mm, Slide Type	
Drawing Date		3rd December 2019	
By	CC	Tolerances (Except as Noted)	Units:
Detail	Drawing Release	Length	Metric (mm)
Revision	A1	Angle	± 1°
Date	28/11/20	X.X ± 0.15	
		X.XX ± 0.10	



This drawing is confidential and copyright of Global Connector Technology, Ltd (GCT). This drawing must not be copied or disclosed without written consent. E & OE



Not to Scale	Drawn By CC	Sheet No. 1/2
--------------	-------------	---------------

H
G
F
E
D
C
B
A

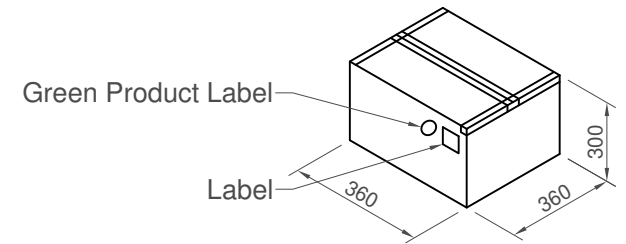
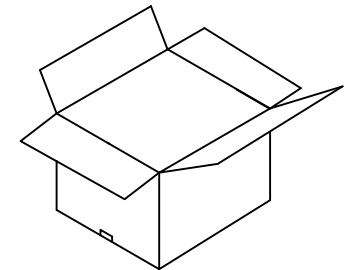
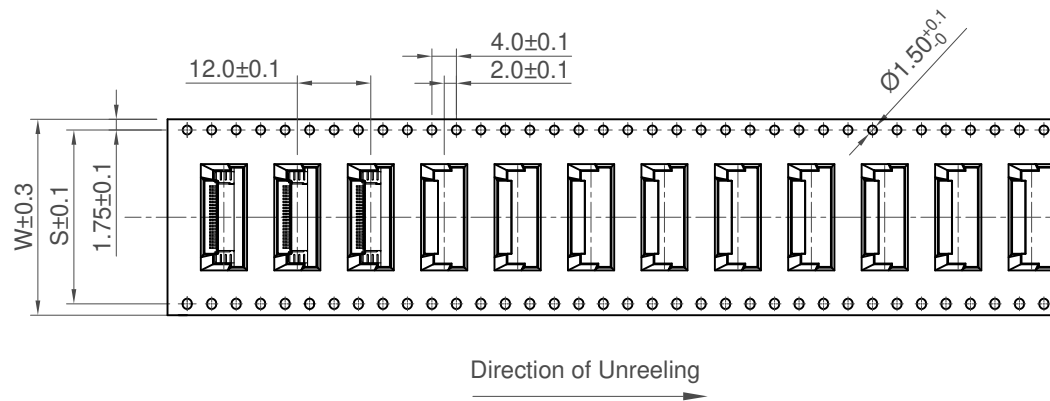
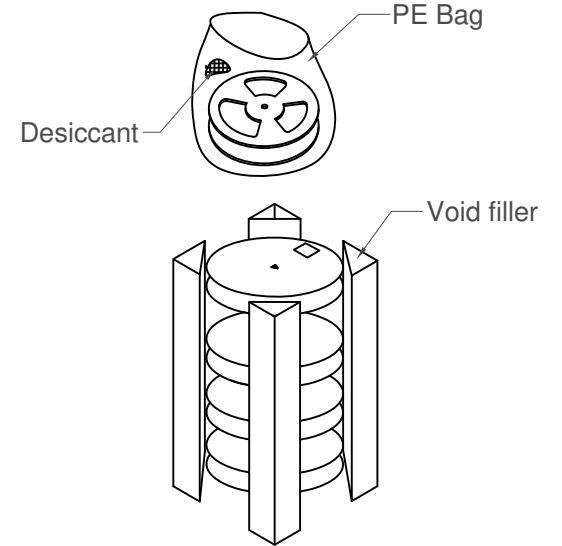
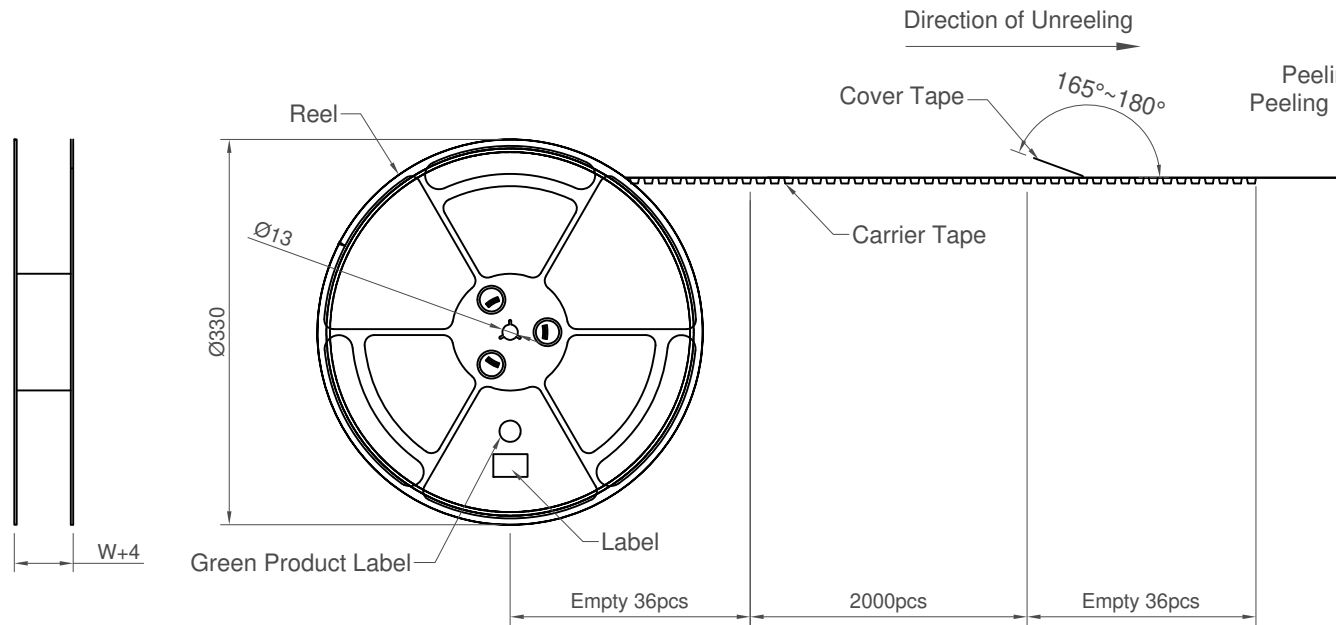

No. of Contacts	W	S	Pcs/Reel	Reel/Carton	Pcs/Carton
4 ~ 19	24	/	2000	10	20000
20 ~ 30	32	28.4	2000	8	16000
31 ~ 40	44	40.4	2000	6	12000

Part Number		Product Description	
FFC2B21		FFC 0.5mm Pitch Side Entry, Bottom Contact, SMT, Height=2.0mm, Slide Type	
Drawing Date		3rd December 2019	
By	CC	Tolerances (Except as Noted)	Units:
Detail	Drawing Release	Length	Metric (mm)
Revision	A1	Angle	
Date	28/11/20		



This drawing is confidential and copyright of Global Connector Technology, Ltd (GCT). This drawing must not be copied or disclosed without written consent. E & OE



Not to Scale	Drawn By CC	Sheet No. 2/2
--------------	----------------	------------------

1 2 3 4 5 6 7 8