

MATERIAL NO.	ENGR. NO.	FINISHED LENGTH
1303030001	130303-0001	39.37" +2.19 - 0 (1.00M +55.6mm - 0)
1303030002	130303-0002	78.74" +3.50 - 0 (2.00M +88.9mm - 0)
1303030009	130303-0009	196.85" +6.50 - 0 (5.00M +165.1mm - 0) (F)

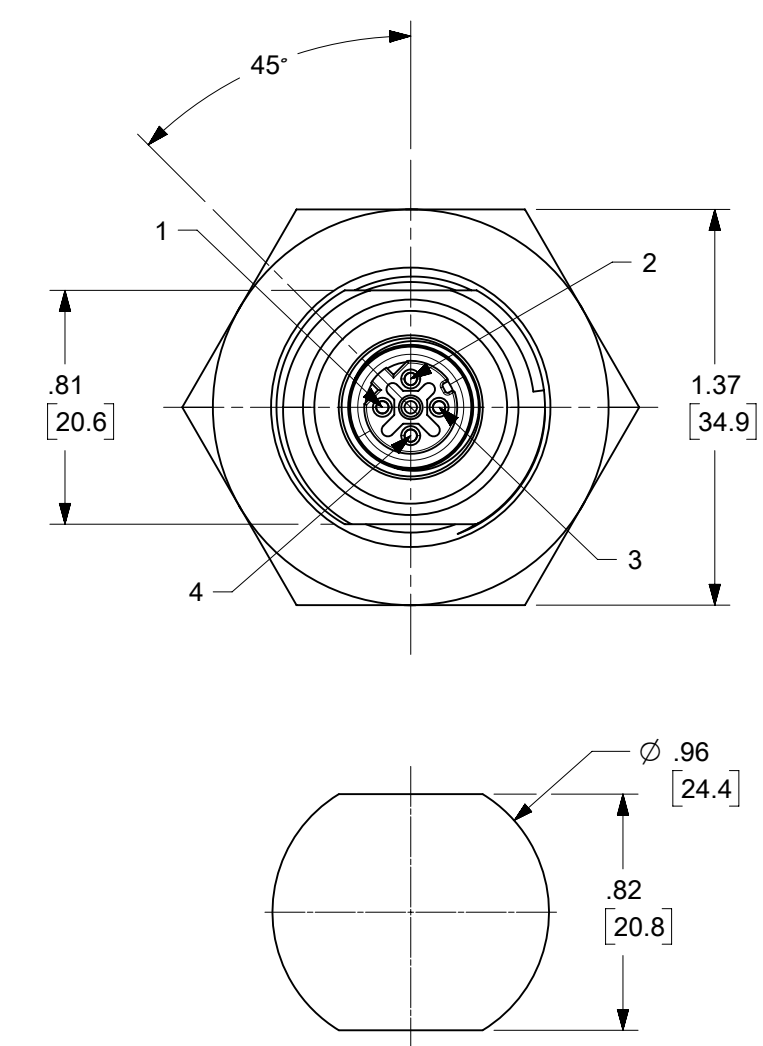

- NOTES:  
 1. ASSEMBLY IS FULLY SHIELDED  
 2. ELECTRICAL RATINGS:  
 VOLTAGE 125 V  
 CURRENT: 1.5 AMPS  
 3. MIN PANEL NUT TORQUE: 12 FT-LBS  
 4. MATERIALS: SEE TABLE  
 5. FINISHES: SEE TABLE  
 6. ASSEMBLY IS TO BE RoHS COMPLIANT  
 7. DIMENSIONS ARE REFERENCE UNLESS OTHERWISE SPECIFIED  
 8. MATES WITH M12 D-CODE MALE

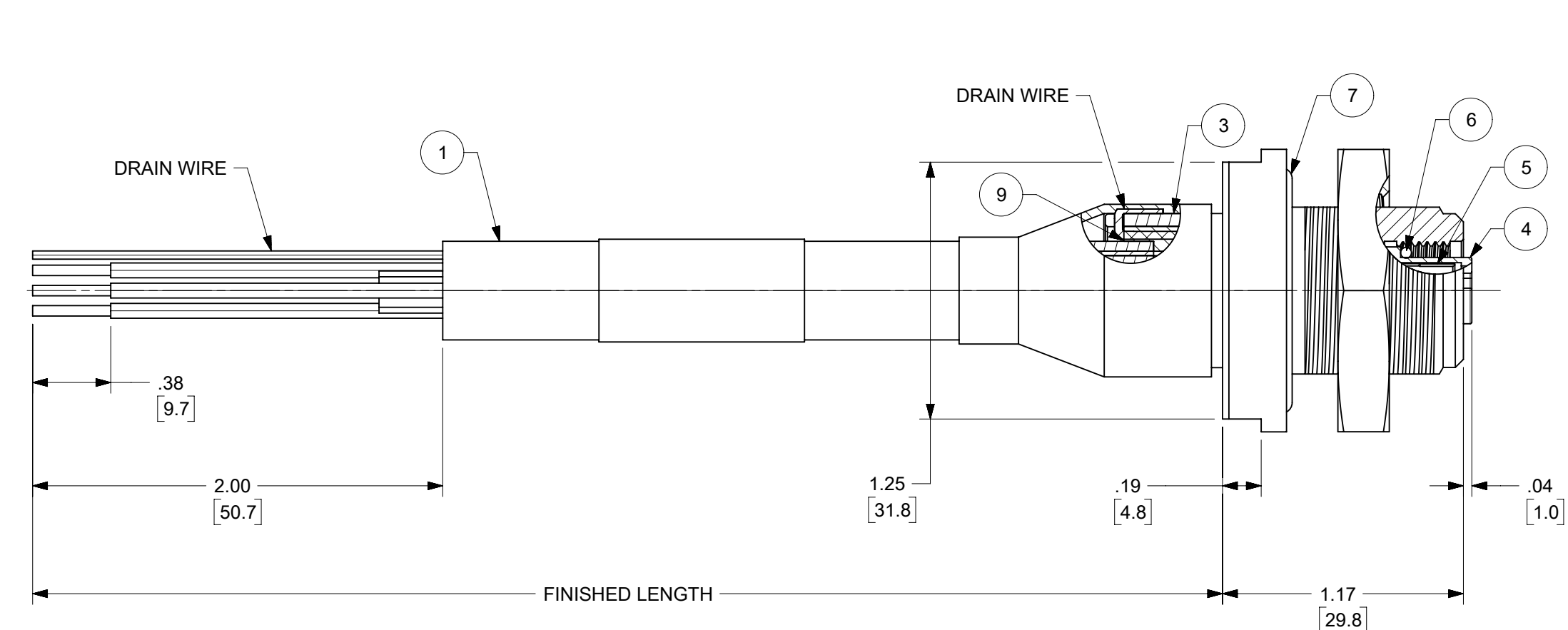
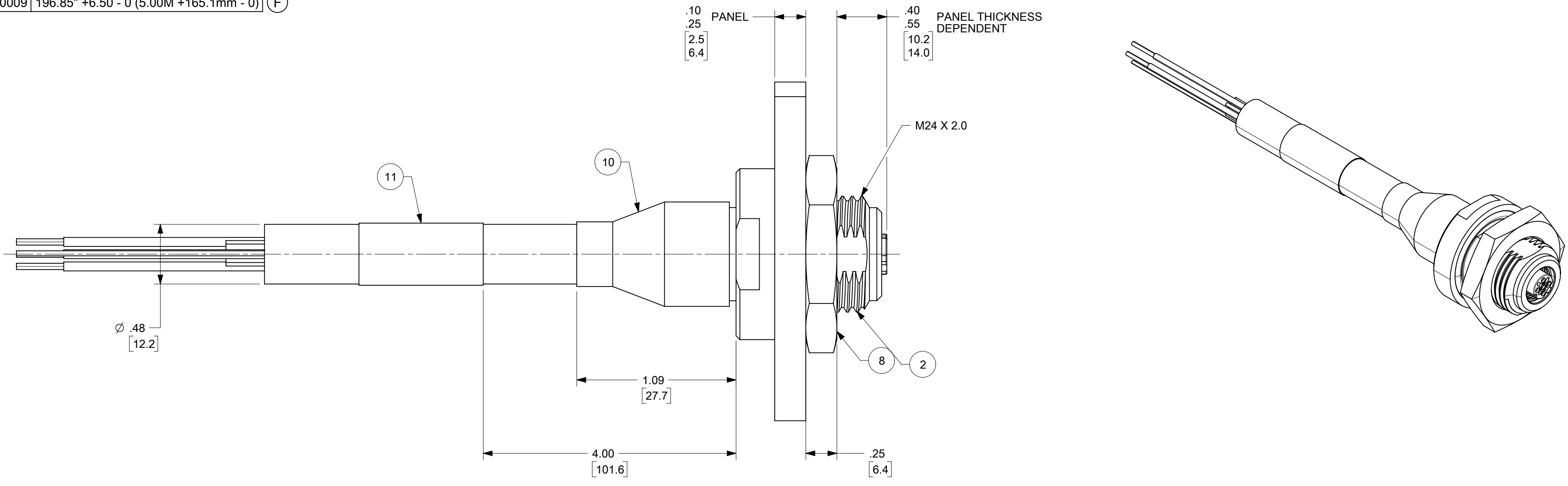
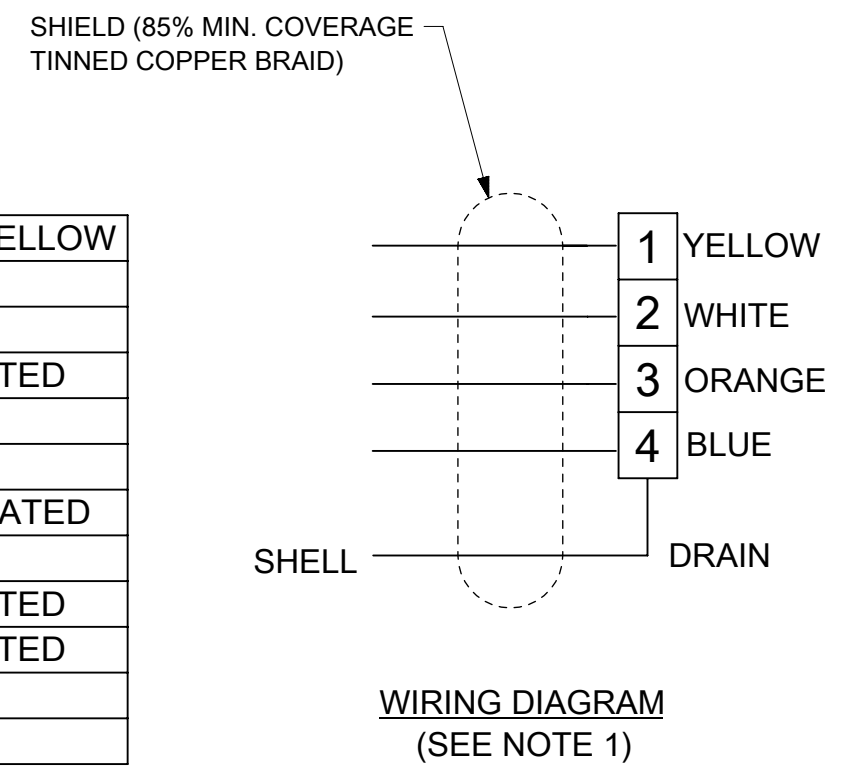

ITEM	DESCRIPTION	MATERIAL	FINISH
11	WRAP LABEL	VINYL	BLACK/YELLOW
10	SHRINK SLEEVE	POLYOLEFIN	BLACK
9	POTTING MATERIAL	PUR	BLUE
8	PANEL NUT, M24X2.0	STAINLESS STEEL	PASSIVATED
7	O-RING PANEL SEAL	VITON	RED
6	O-RING MATING SEAL	VITON	RED
5	FEMALE CONTACT SOCKET	Cu ALLOY	GOLD PLATED
4	FEM. INSULATOR, 4/C, D-CODE (ANTI-ROTATE)	NYLON	BLACK
3	RECEPTACLE SLEEVE	STAINLESS STEEL	PASSIVATED
2	RECEPTACLE SHELL (ANTI-ROTATE)	STAINLESS STEEL	PASSIVATED
1	CABLE, 18AWG SHIELDED WITH DRAIN	XLE	BLACK
ITEM	DESCRIPTION	MATERIAL	FINISH

FUNCTIONAL SYMBOLS		THIS DRAWING CONTAINS INFORMATION THAT IS PROPRIETARY TO MOLEX ELECTRONIC TECHNOLOGIES, LLC AND SHOULD NOT BE USED WITHOUT WRITTEN PERMISSION		CURRENT REV DESC: ADD NEW 5M LENGTH 1303030009, UPDATE TO LATEST DOC STANDARD	
FA = 0	DIMENSION UNITS	SCALE	EC NO: 642084		
EA = 0	INCH/MM	NTS	DRWN: MZIELINSKI 2020/07/21		
EP = 0	GENERAL TOLERANCES (UNLESS SPECIFIED)		CHK'D: ALEON01 2020/07/29		
DIVISIONAL SYMBOLS		ANGULAR TOL ± °	APPR: BWOODMAN 2020/07/31		
4 PLACES ±		INITIAL REVISION:			
3 PLACES ±		DRWN: RSTONE 2010/02/15			
2 PLACES ±		APPR: DTITUS 2010/03/23			
1 PLACE ±		DRAFT WHERE APPLICABLE MUST REMAIN WITHIN DIMENSIONS			
0 PLACES ±		THIRD ANGLE PROJECTION	DRAWING	SERIES	MATERIAL NUMBER
			C-SIZE	130303	SEE TABLE
		CUSTOMER		SHEET NUMBER	
		GENERAL MARKET		1 OF 1	

**molex**

MIC RECEPTACLE ASSEMBLY  
HDEX, FEM, D-CODE, M12 18 AWG, MAX LOAD FRONT

PRODUCT CUSTOMER DRAWING

DOCUMENT NUMBER: SD-130303-001  
 DOC TYPE: PSD  
 DOC PART: 001  
 REVISION: F

MATERIAL NUMBER: SEE TABLE  
 CUSTOMER: GENERAL MARKET  
 SHEET NUMBER: 1 OF 1