

Absolute maximum ratings

($T_a=25^\circ\text{C}$)

Symbol	Ratings		Unit
	N channel	P channel	
V_{DSS}	60	-60	V
V_{GSS}	± 20	∓ 20	V
I_D	4	-4	A
$I_D(\text{pulse})$	8 ($PW \leq 1\text{ms}$, $Duty \leq 25\%$)	-8 ($PW \leq 1\text{ms}$, $Duty \leq 25\%$)	A
P_T	5 ($T_a=25^\circ\text{C}$, with all circuits operating, without heatsink)		W
	30 ($T_c=25^\circ\text{C}$, with all circuits operating, with infinite heatsink)		W
θ_{j-a}	25 (Junction-Air, $T_a=25^\circ\text{C}$, with all circuits operating)		$^\circ\text{C/W}$
θ_{j-c}	4.17 (Junction-Case, $T_c=25^\circ\text{C}$, with all circuits operating)		$^\circ\text{C/W}$
Tch	150		$^\circ\text{C}$
Tstg	-40 to +150		$^\circ\text{C}$

Equivalent circuit diagram

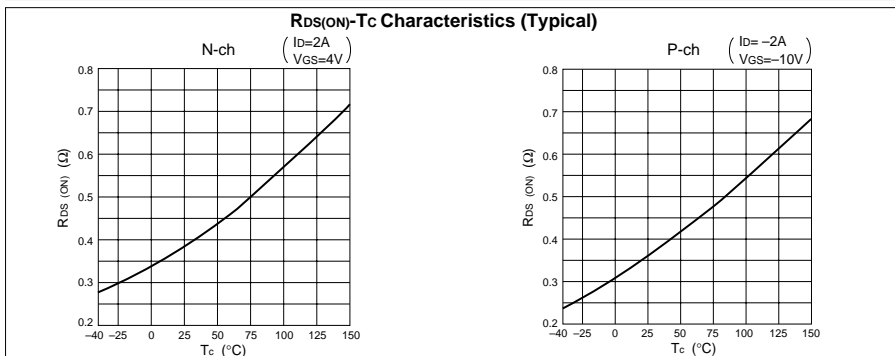
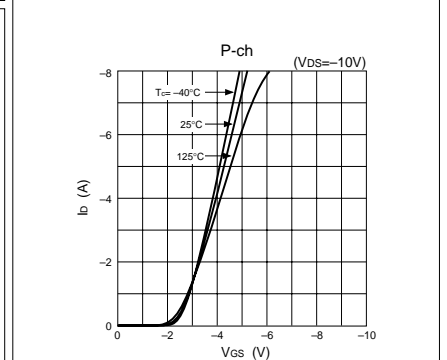
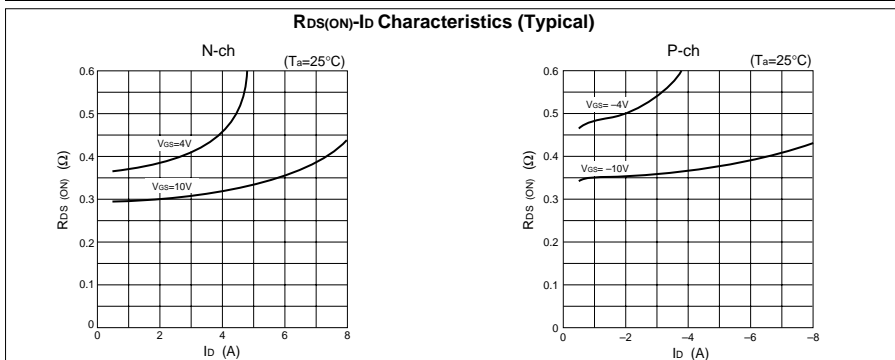
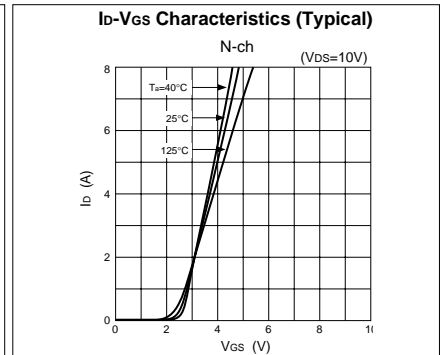
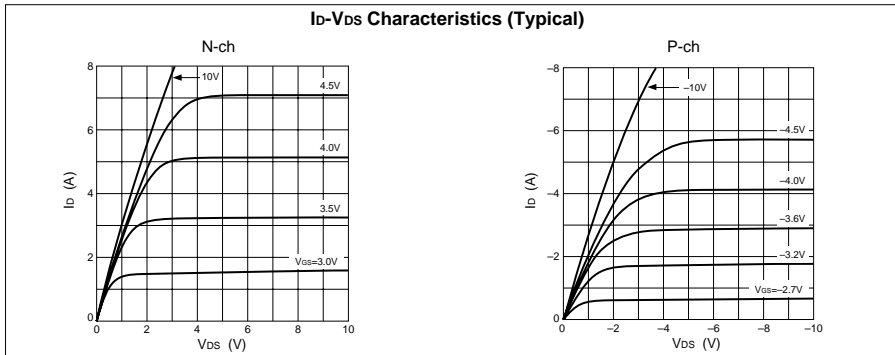
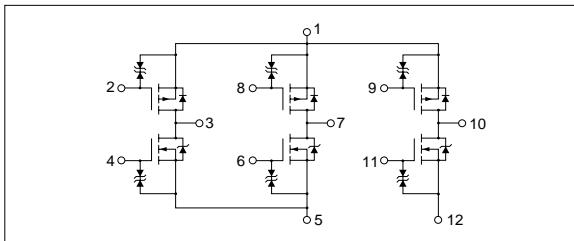

Electrical characteristics

($T_a=25^\circ\text{C}$)

Symbol	N channel					P channel				
	Specification			Unit	Conditions	Specification			Unit	Conditions
	min	typ	max			min	typ	max		
$V_{(BR)DSS}$	60			V	$I_D=100\mu\text{A}$, $V_{GS}=0\text{V}$	-60			V	$I_D=-100\mu\text{A}$, $V_{GS}=0\text{V}$
I_{GSS}			± 10	μA	$V_{GS}=\pm 20\text{V}$			∓ 10	μA	$V_{GS}=\mp 20\text{V}$
I_{DSS}			100	μA	$V_{DS}=60\text{V}$, $V_{GS}=0\text{V}$			-100	μA	$V_{DS}=-60\text{V}$, $V_{GS}=0\text{V}$
V_{TH}	1.0		2.0	V	$V_{DS}=10\text{V}$, $I_D=250\mu\text{A}$	-1.0		-2.0	V	$V_{DS}=-10\text{V}$, $I_D=-250\mu\text{A}$
$R_{e(yfs)}$		2.5		S	$V_{DS}=10\text{V}$, $I_D=2\text{A}$		3		S	$V_{DS}=-10\text{V}$, $I_D=-2\text{A}$
$R_{DS(ON)}$			0.55	Ω	$V_{GS}=4\text{V}$, $I_D=2\text{A}$			0.55	Ω	$V_{GS}=-10\text{V}$, $I_D=-2\text{A}$
C_{iss}		150		pF	$V_{DS}=10\text{V}$, $f=1.0\text{MHz}$, $V_{GS}=0\text{V}$		320		pF	$V_{DS}=-10\text{V}$, $f=1.0\text{MHz}$, $V_{GS}=0\text{V}$
C_{oss}		70		pF			130		pF	
C_{rss}		15		pF			40		pF	
$t_{d(on)}$		12		ns	$I_D=2\text{A}$, $V_{DD}=20\text{V}$, $R_L=10\Omega$, $V_{GS}=5\text{V}$, see Fig. 3 on page 16.		20		ns	$I_D=-2\text{A}$, $V_{DD}=-20\text{V}$, $R_L=10\Omega$, $V_{GS}=-5\text{V}$, see Fig. 4 on page 16.
t_r		40		ns			95		ns	
$t_{d(off)}$		40		ns			70		ns	
t_f		25		ns			60		ns	
V_{SD}		1.2		V	$I_{SD}=4\text{A}$, $V_{GS}=0\text{V}$		-1.1		V	$I_{SD}=-4\text{A}$, $V_{GS}=0\text{V}$
t_{rr}		75		ns	$I_{SD}=2\text{A}$, $V_{GS}=0\text{V}$, $di/dt=100\text{A}/\mu\text{s}$		75		ns	$I_{SD}=-2\text{A}$, $V_{GS}=0\text{V}$, $di/dt=100\text{A}/\mu\text{s}$

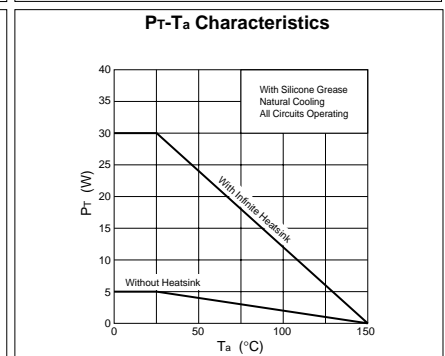
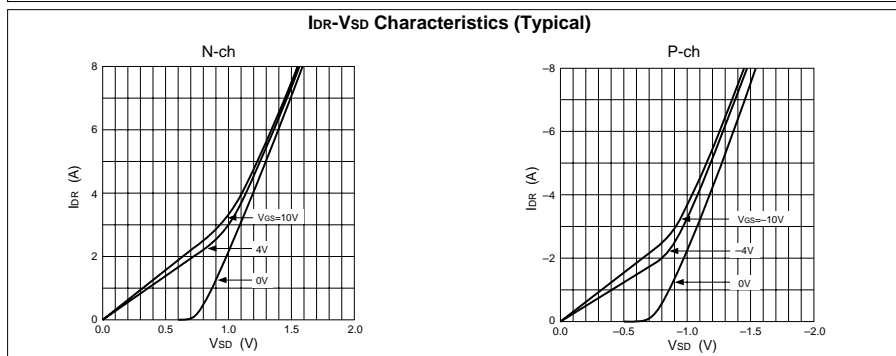
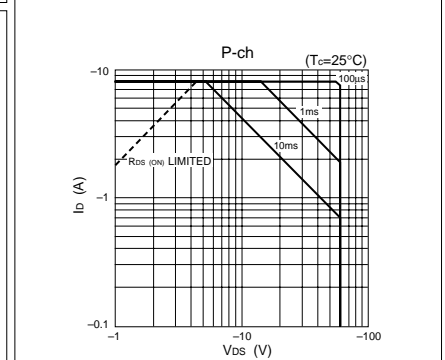
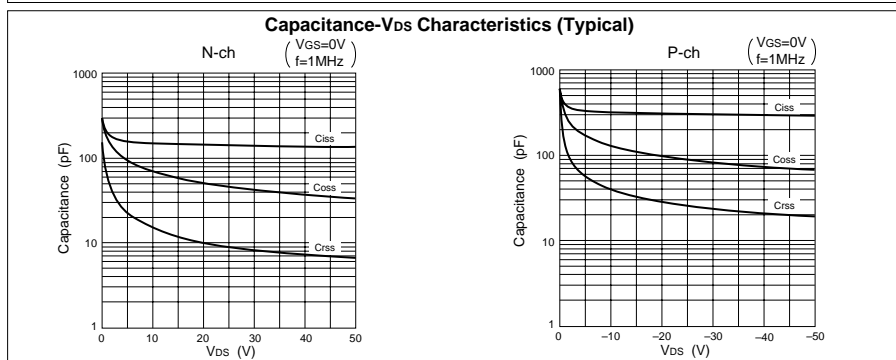
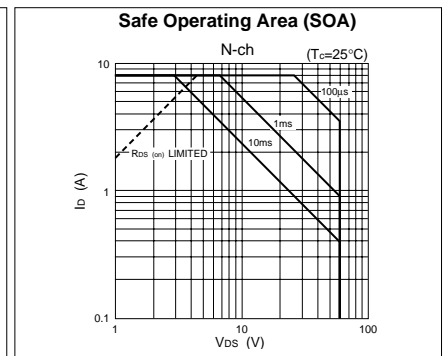
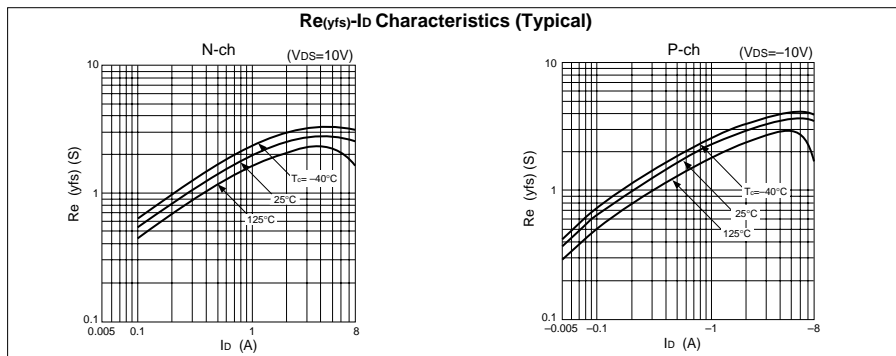

• SIP 8 (STA8Pin)

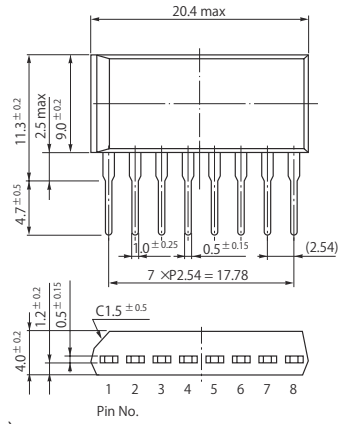

• SIP 10 (STA10Pin)

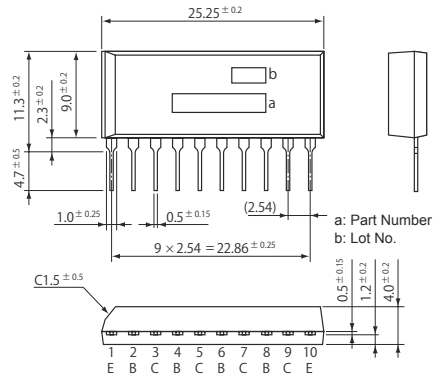

• SIP 12 (SMA12Pin)

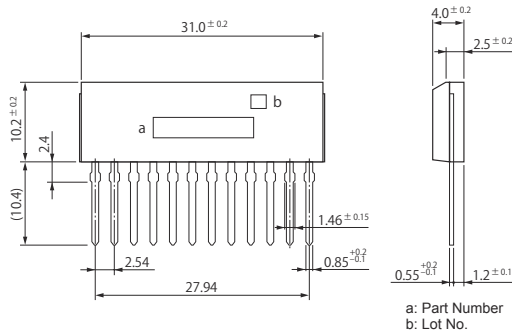

• SIP 15 (SMA15Pin)

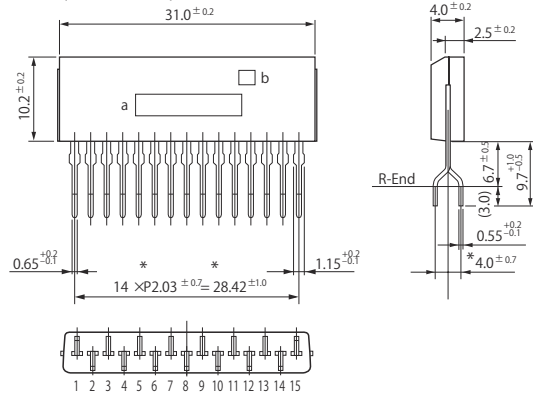

• SIP 12 with Fin (SLA12Pin)

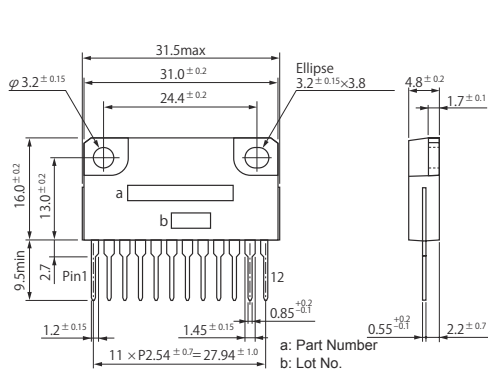

• SIP 15 with Fin (SLA15Pin)

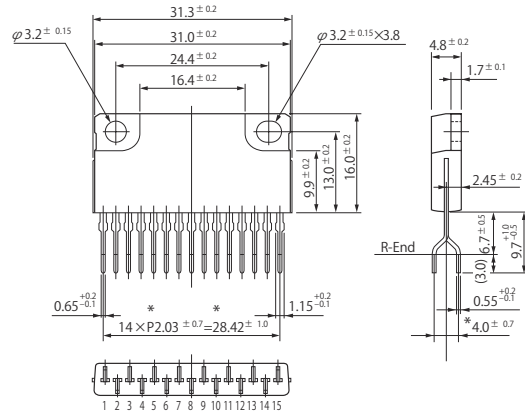

• SIP 21 with Fin (SLA21Pin)

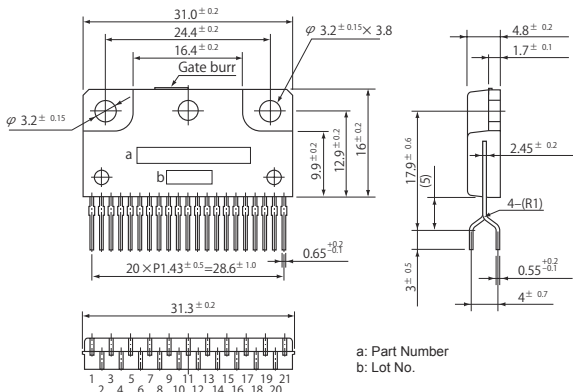

(Unit:mm)