

4

3

2

1

THIS DRAWING IS UNPUBLISHED. RELEASED FOR PUBLICATION ,19 .
 © COPYRIGHT 19 BY AMP INCORPORATED. ALL RIGHTS RESERVED.

| LOC | DIST | REVISIONS | | | | | |
|-----|------|-----------|-----|--------------------------|---------|-----|------|
| | | P | LTR | DESCRIPTION | DATE | DWN | APVD |
| G | 14 | | J | REDRAWN PER 0G3A-0249-01 | 03APR01 | JR | TM |

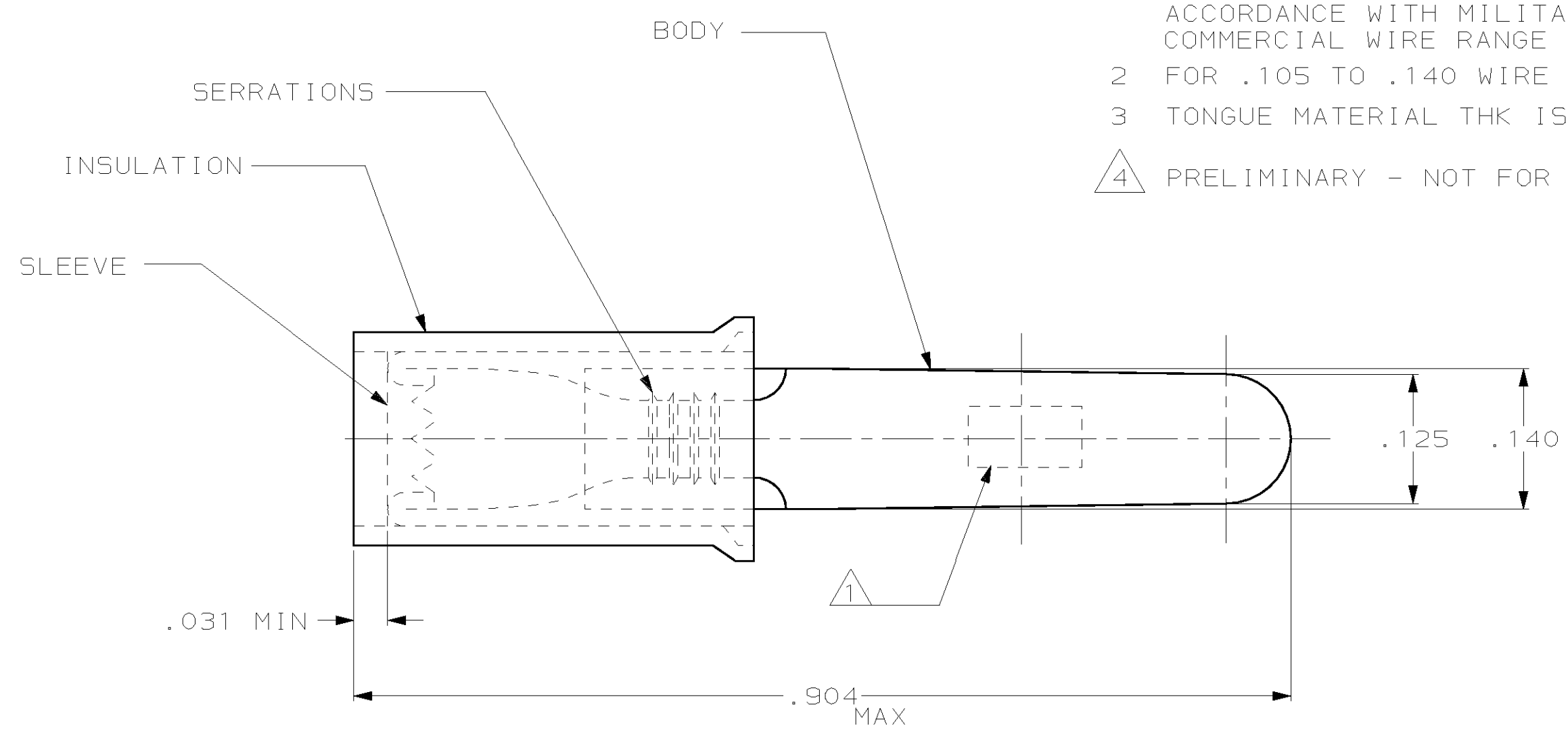

- 1 STAMPED AMP 22-18*, APPROX AS SHOWN. 22-16 TERMINALS ARE STAMPED 22-18 IN ACCORDANCE WITH MILITARY SPEC MIL-T-7928 COMMERCIAL WIRE RANGE 22-16
- 2 FOR .105 TO .140 WIRE INSULATION DIA.
- 3 TONGUE MATERIAL THK IS .031±.002.
- 4 PRELIMINARY - NOT FOR PRODUCTION

| | | | | | | |
|--|------------------|-----------|---|---|----------------------|--|
| 100 | LOOSE PIECE, BOX | 8-34294-1 | BODY: COPPER PER ASTM B152 TIN PLATE PER ASTM B545 | | | |
| 5000 | ON TAPE, REEL | 2-34294-1 | 4 | SLEEVE: COPPER PER ASTM B152 TIN PLATE PER ASTM B545 | | |
| 1000 | LOOSE PIECE | 34294 | INSULATION: NYLON, COLOR - RED | | | |
| QTY | PACKAGE TYPE | PART NO. | MATERIAL & FINISH | | | |
| THIS DRAWING IS A CONTROLLED DOCUMENT. | | | DWN | JR RUTH | 03APR01 | AMP AMP Incorporated Harrisburg, PA 17105-3608 |
| | | | CHK | MS FEHER | 03APR01 | |
| DIMENSIONS: INCHES | | | TOLERANCES UNLESS OTHERWISE SPECIFIED: | | NAME | |
| | | | 0 PLC ±- | | WIRE TERMINAL, PIDG, | |
| | | | 1 PLC ±- | | RECTANGULAR TAB, | |
| | | | 2 PLC ±- | | WIRE SIZE: 22-16 | |
| | | | 3 PLC ±.008 | | SIZE | |
| | | | 4 PLC ±- | | CAGE CODE | |
| | | | ANGLES ±5° | | DRAWING NO | |
| MATERIAL - | | | FINISH - | | RESTRICTED TO | |
| | | | | | A3 00779 C- 34294 | |
| CUSTOMER DRAWING | | | SCALE 8:1 | | SHEET 1 OF 1 | |
| | | | | | REV J | |