

Order Number
213069-4510

molex

Application Tooling Specification

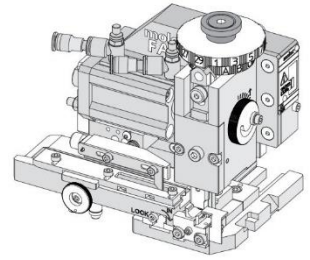

FEATURES

- Applicator designed to industry-standard mounting and 135.80mm (5.346") shut height
- Quick setup time; plus, the crimp height, track and feed adjustments can be set without removing the applicator from the press
- Fine adjustment allows users to achieve target with little effort by adjusting in increments of 0.015mm (.0006") for conductor crimp height and 0.025mm (.001") for insulation height
- Independent adjustment rings allow users to quickly adjust the conductor or insulation crimp height without affecting each other
- Directly adapts to most automatic wire processing machines
- This applicator is configured with a pneumatic feed, which requires a 4-way pneumatic valve for operation

SCOPE

Products: Micro-Lock Plus 2.0 Crimp Terminals, 22-24 AWG, UL1061 Wire.

Terminal Series No.	Terminal Order No.	Wire		Insulation Diameter		Strip Length	
		Wire Type	Size	mm	In.	mm	In.
213720	213720-1000	UL1061	22 AWG 24 AWG	0.90-1.50	.079-.110	4.30-4.80	.169-.189

CAUTION: To operate the pneumatic feed, a 4-way pneumatic valve is required.

DEFINITION OF TERMS

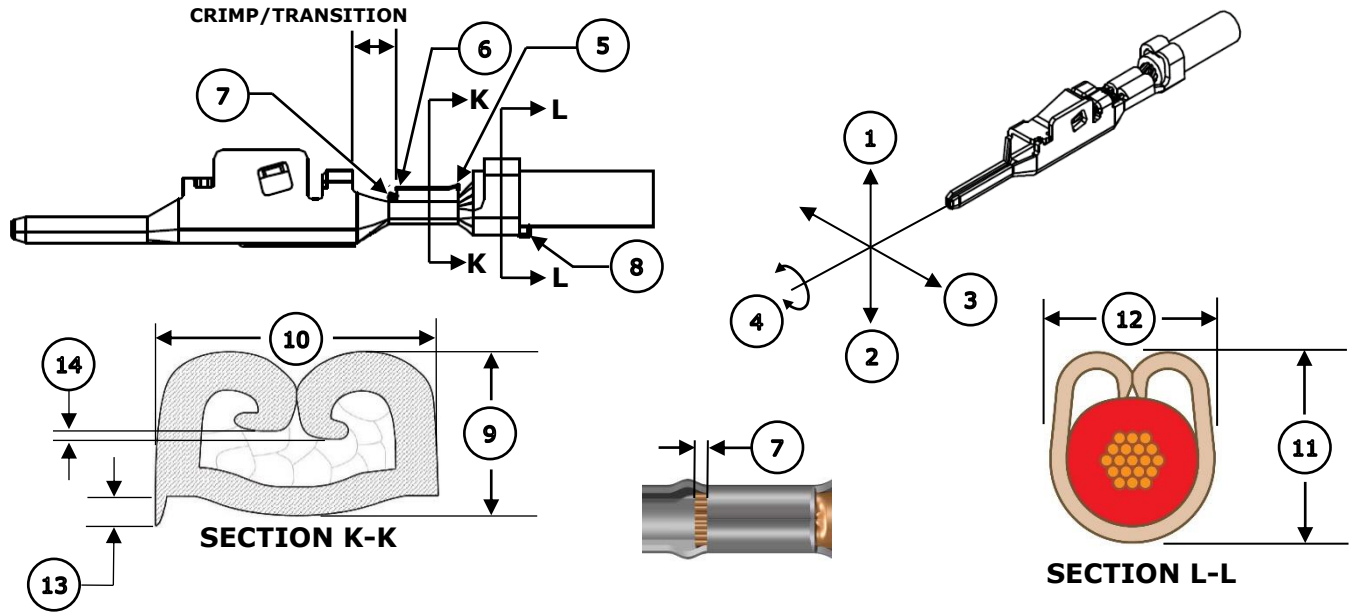

CRIMP SPECIFICATIONS

Feature	Requirement				
1. Bend Up	3° Max				
2. Bend Down	3° Max				
3. Twist	2° Max				
4. Roll	4° Max				
5. Bell Mouth Rear	0.10-0.45mm (.004-.018")				
6. Bell Mouth Front	Not Applicable				
7. Conductor Brush	0.10-0.65mm (.004-.026")				
8. Cut-Off Tab	0.10mm (.004") Max				
Conductor Crimp	Wire Size	9. Crimp Height		10. Crimp Width	
	22 AWG	0.78-0.83mm	.031-.033 in.	1.18-1.28mm	.046-.050 in.
24 AWG	0.70-0.75mm	.028-.030 in.			
Insulation Crimp	Wire Size	11. Crimp Height		12. Crimp Width	
	22 AWG	1.69-1.79mm	.067-.070 in.	1.54-1.64mm	.061-.065 in.
24 AWG	1.61-1.79mm	.063-.070 in.			
Pull Force	Wire Size	Minimum Force		To be measured with no influence from the insulation crimp.	
	22 AWG	39.2 N	8.8 lb.		
24 AWG	29.4 N	6.6 lb.			
13. Conductor Anvil Flash	0.075mm (.003") Max				
14. Wing Dissymmetry	0.20mm (.008") Max				

NOTES

Specification Notes

- It is very important that the brush length is consistently within specification for this sealed connector system to work properly.
- This applicator should only be run in a properly set up wire processor to consistently achieve the brush length.

General Notes

1. Molex recommends that an extra perishable tooling kit be maintained at your facility.
2. Verify tooling alignment by hand cycling the press and applicator before crimping under power. Check that all screws are tight.
3. Slugs, terminals, dirt and oil should be kept clear of the work area.
4. Wear safety glasses at all times.
5. For recommended maintenance, refer to the FA2 manual (TM-638080200).
6. Molex recommends crimping stranded copper wire only.

WARNINGS

CAUTION: This applicator must be installed in a press with a standard shut height of 135.80mm (5.346"). Tooling damage could result at a lower setting.

CAUTION: To prevent injury, never operate this applicator without the guards supplied with the press or wire-processing machine in place. Reference the press or wire processing manufacturer's instruction manual.

CAUTION: Molex tooling crimp specifications are valid only when used with Molex terminals and tooling manufactured by Molex and sold by Molex or authorized distributors ("Molex Tooling"). When using tooling other than Molex Tooling with Molex-specific connector systems listed in our ATS documents, the Molex Tooling qualification does not apply, and the responsibility for full qualification of the connector system is that of the customer. Molex accepts no liability for connector performance or tooling support where tooling other than Molex Tooling is used or where Molex Tooling is modified.

PARTS LIST

FA2 Applicator 213069-4510				
Item	Order No.	Engineering No.	Description	Quantity
Perishable Tooling				
	213069-4570	213069-4570	Tool Kit (All "Y" Items)	Ref
1	200220-1510	200220-1510	Insulation Punch	1 Y
2	200216-1202	200216-1202	Conductor Punch	1 Y
3	200221-1402	200221-1402	Insulation Anvil	1 Y
4	200217-1207	200217-1207	Conductor Anvil	1 Y
5	63443-0136	63443-0136	Cut-Off Plunger	1 Y
6	63443-0119	63443-0119	Cutting Insert	1 Y
Non-Perishable Components				
7	63443-0118	63443-0118	Front Plunger Retainer	1
8	01124-1067	4996-4	Cut-Off Plunger Spring	1
9	63443-0117	63443-0117	Front Scrap Chute	1
10	63443-2207	63443-2207	Coarse Spacer	1
11	63443-2807	63443-2807	Front Plunger Striker	1
12	63443-2905	63443-2905	Wire Hold Down Plunger	1
13	63600-0021	63600-0021	Wire Hold Down Spring	1
14	63600-5775	63600-5775	Nose Hold Down Shank	1
15	63700-0992	63700-0992	Terminal Hold Down Plunger Spring	1
16	63443-7338	63443-7338	Terminal Hold Down	1
17	63443-4716	63443-4716	Terminal Guide	1
18	63808-0220	63808-0220	Hold Down Block	1
19	63808-0229	63808-0229	Bend Adjust Dial	1
20	63443-7315	63443-7315	Terminal Hold Down Plunger	1
21	63443-7316	63443-7316	Terminal Hold Down Retainer	1
22	63443-7317	63443-7317	Terminal Hold Down Plate	1
23	63808-0249	63808-0249	Feed Pawl	1
24	203045-0030	203045-0030	Feed Pawl Spring	1
Frame				
25	63808-0200	63808-0200	Applicator Core	1
26	63808-0196	63808-0196	Pneumatic Feed Assembly	1
27	63808-0191	63808-0191	Track Assembly	1
Hardware				
28	—	—	M2.5 x 4 SHCS	2*
29	—	—	M3 Hex Nut	1*
30	—	—	M3 Flat Washer Hard	1*
31	—	—	M3 Inner Tooth Lock Washer	1*
32	—	—	M3 x 6 BHCS	2*
33	—	—	M3 x 10 SHCS	2*
34	—	—	M3 x 12 SHCS	4*
35	—	—	M4 x 5 SSS	1*
36	—	—	M4 x 6 SHCS	1*
37	—	—	M4 x 45 SHCS	2*
38	—	—	M5 Hex Jam Nut	1*
39	—	—	M5 x 12 Long Cup Point SSS	1*
*Fastener parts can be purchased through most industrial suppliers by using the description in the table above.				

ASSEMBLY DRAWING

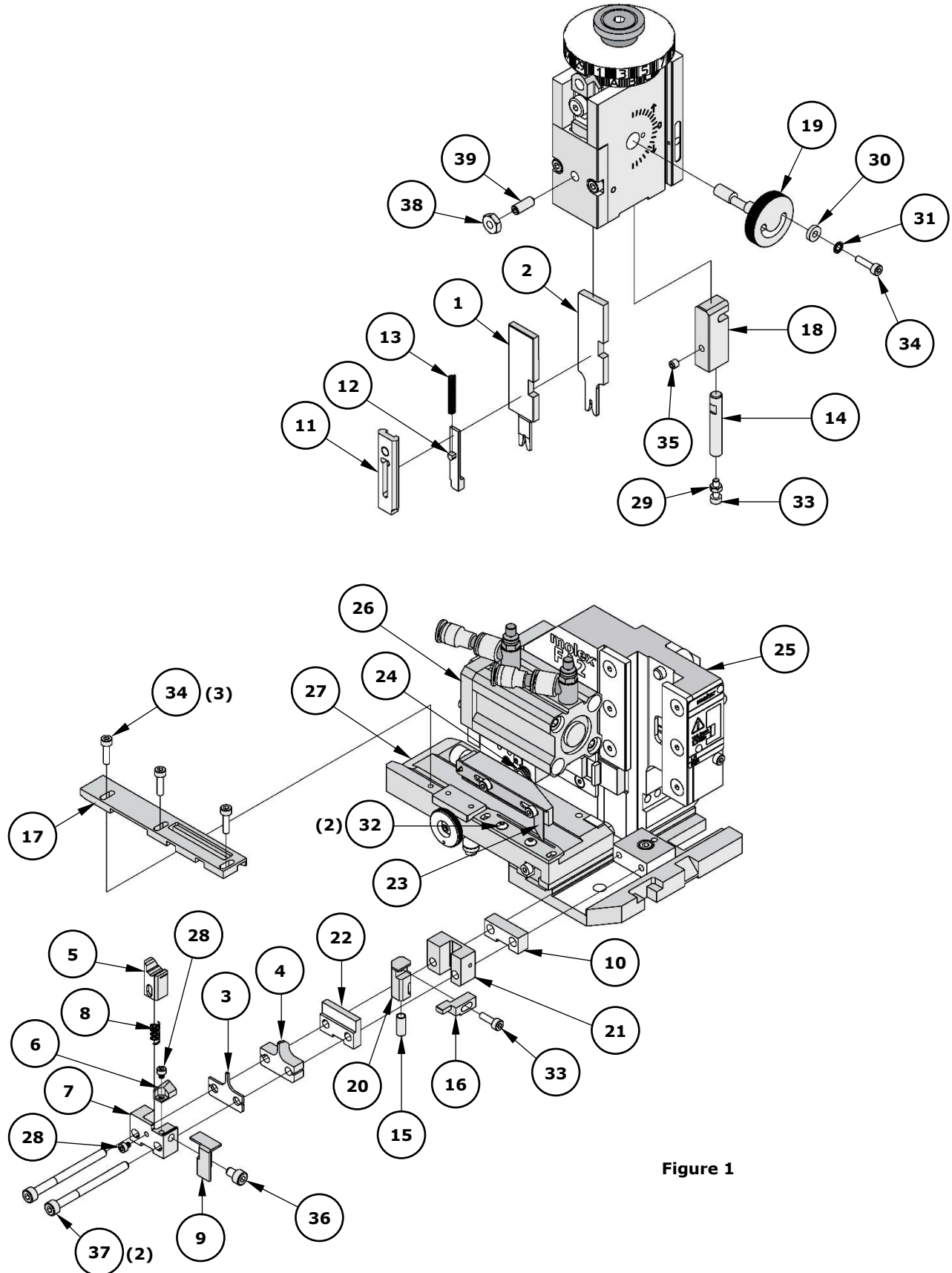

Figure 1

FACTORY SETTINGS

Feed Pawl Assembly

The FA2 applicator number 213069-4510 ships with the following factory settings. See Figure 2:

- The feed pawl shaft and M3 screw that holds the feed pawl spring are in position 2.
- The pin is in position B.

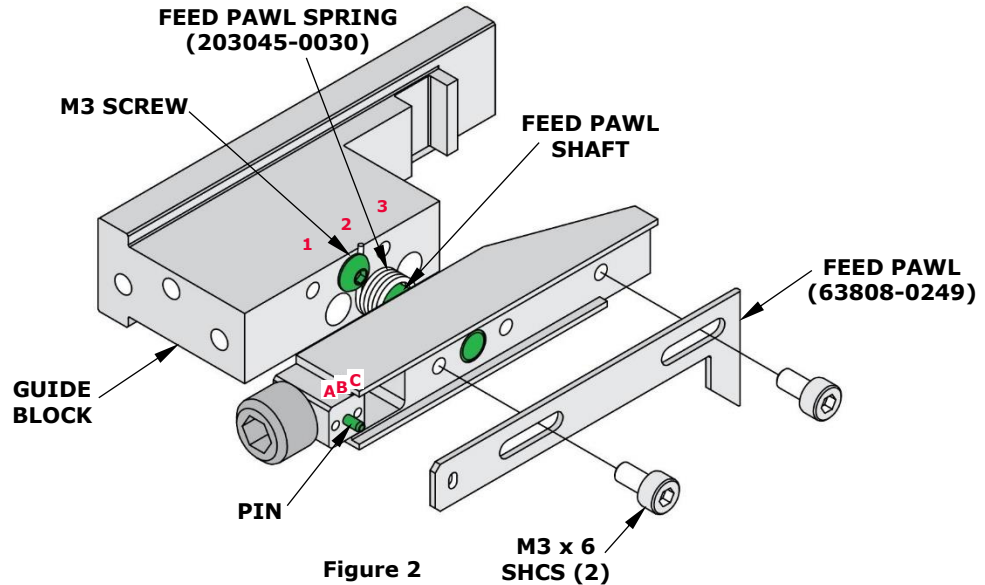

Note: Each applicator is configured and tested by Molex prior to shipping, and the above settings were used to produce the included sample crimps.

Third Dial/Ram Assembly

○ Indicates item number on the Parts List and Assembly Drawing

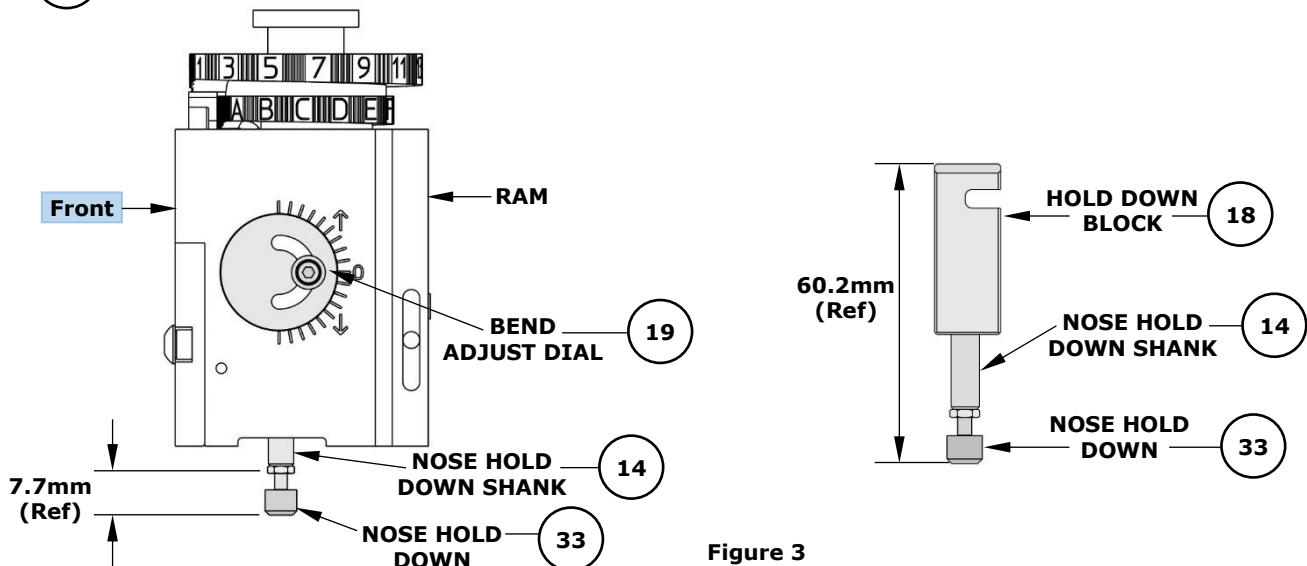

Note: The above dimensions were measured during setup and are included as a reference only. Additional adjustments may be required before crimping for production.

Mounting Datum Location

This applicator was assembled and tested by Molex with the mounting datum in the location shown in Figure 4. Do not remove the mounting datum.

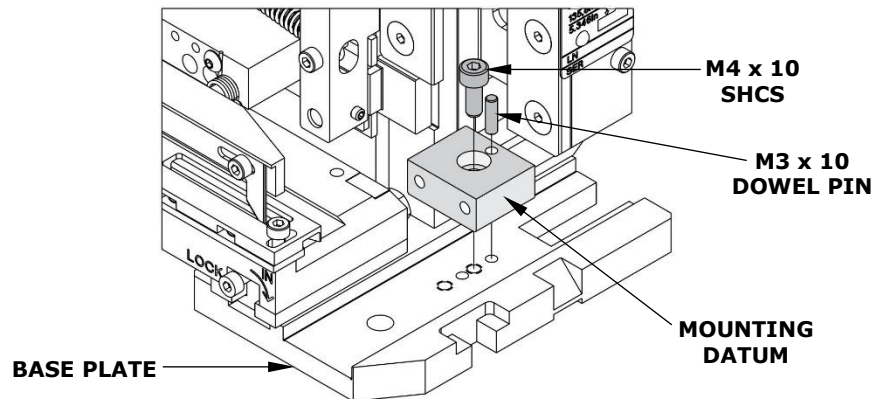

Figure 4

PNEUMATIC CONNECTION (AIR FEED)

- The pneumatic feed applicator uses a double-acting air cylinder that must be actuated by a 4-way pneumatic valve.
- The air cylinder is equipped with push-in fittings for 6mm diameter vinyl or Nylon tube. Adapters are included for 1/4" diameter and 4mm diameter vinyl or Nylon tube.

Note: The TM-3000 and TM-4000 presses have pneumatic valves with 1/4" diameter tube fittings. Be sure to install the 1/4" diameter adapters in the air cylinder fittings and use 1/4" diameter vinyl or Nylon tube.

- Pneumatic tubes must be connected as shown in Figure 5. Tubes are typically connected so the terminal feed is forward when the applicator ram is up.
- When using the TM-3000 or TM-4000 presses, connect the tubes to the press pneumatic valve as shown in Figure 6.

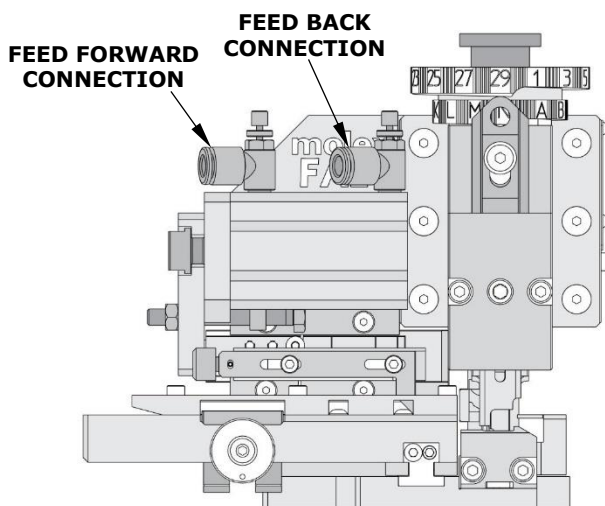

Figure 5

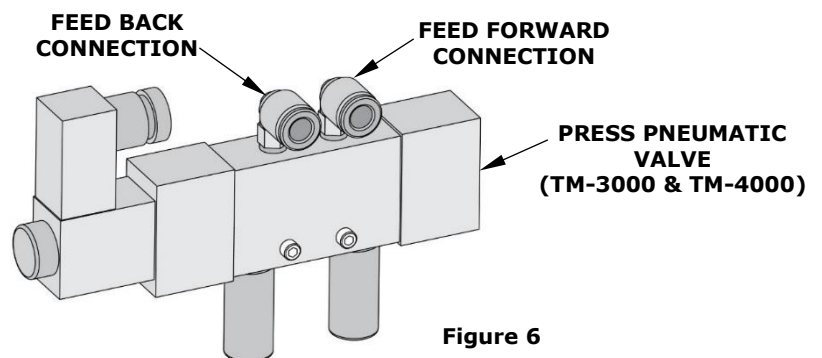

Figure 6

Application Tooling Support

Phone: (402) 458-TOOL (8665)

E-Mail: toolingsupport@molex.com

Website: www.molex.com/applicationtooling

Molex is a registered trademark of Molex, LLC in the United States of America and may be registered in other countries; all other trademarks listed herein belong to their respective owners.