

THIS DRAWING IS UNPUBLISHED. RELEASED FOR PUBLICATION  
 © COPYRIGHT 2010 BY TYCO ELECTRONICS CORPORATION. ALL RIGHTS RESERVED.

LOC	DIST	REVISIONS			
P	LTR	DESCRIPTION	DATE	DWN	APVD
	C2	ECO-20-002959	02MAR2020	RR	SH

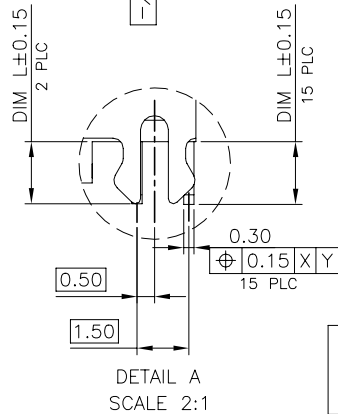

- NOTES:
- MATERIAL:
    - 1.1 HOUSING: LCP WITH 30% GF, UL 94V-0, COLOR: BLACK.
    - 1.2 CAP: LCP WITH 30% GF, UL 94V-0, COLOR: BLACK.
    - 1.3 CONTACTS: BRASS.
    - 1.4 SHELL: SPCC.
  - FINISH:
    - 2.1 CONTACTS: GOLD FLASH ON CONTACT AREA, 2.54um [100u"] MIN. MATTE-TIN PLATED ON SOLDER TAIL, 1.27um [50u"] MIN. NICKEL UNDERPLATED OVERALL.
    - 2.2 SHELL: 2.54um [100u"] MIN. NICKEL PLATED OVERALL.
  - REFLOW SOLDER CAPABLE TO 260°C PER TEC-109-201, METHOD B, CONDITION B.
  - LOW HALOGEN SPECIFICATION:
    - CHLORINE(Cl): 900ppm MAX.
    - BROMINE(Br): 900ppm MAX.
    - CHLORINE(Cl)+BROMINE(Br): 1500ppm MAX.

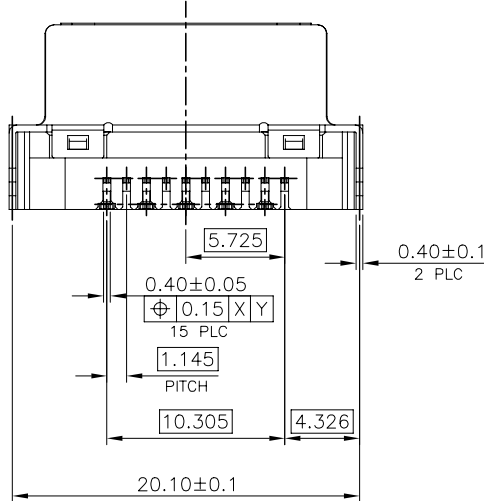
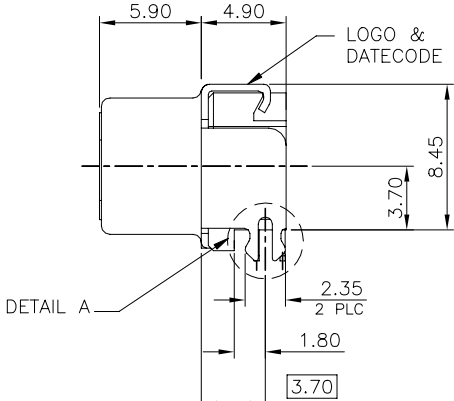
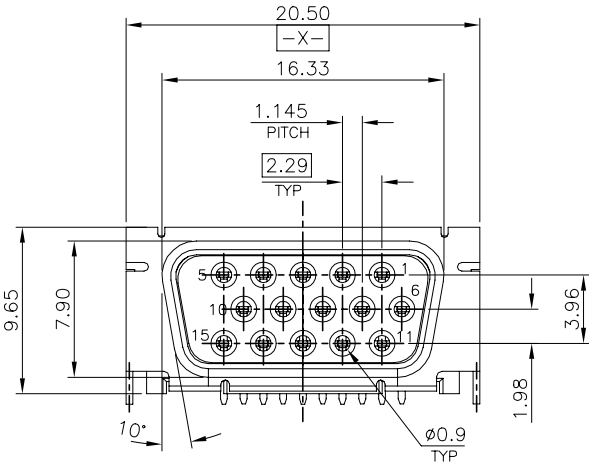
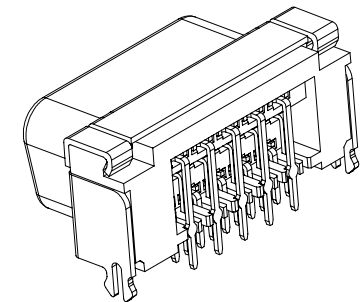
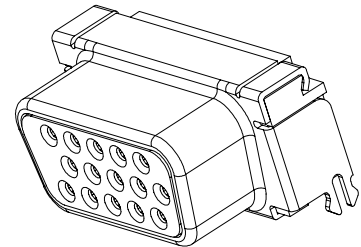

OBSOLETE

OBSOLETE	1.20	<del>2041372-2</del>
OBSOLETE	1.80	<del>2041372-1</del>
	DIM L	PART NUMBER

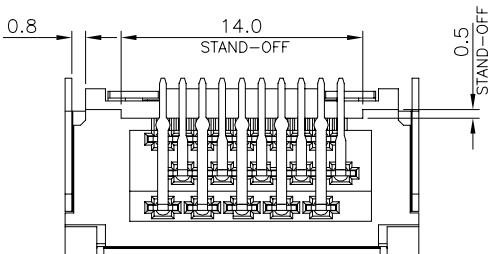

THIS DRAWING IS A CONTROLLED DOCUMENT.		DWN J. CHEN 27JUL2011		
DIMENSIONS: mm		CHK S. CHIEN 27JUL2011		
TOLERANCES UNLESS OTHERWISE SPECIFIED:		APVD W. KODAMA 27JUL2011	NAME	
0 PLC ± -		PRODUCT SPEC	D-SUB CONNECTOR, RECEPTACLE ASSEMBLY, 15P, SLIM, RIGHT ANGLE, DIP TYPE, H=8.45mm	
1 PLC ± 0.3		APPLICATION SPEC	108-57868	
2 PLC ± 0.2		WEIGHT	SIZE	CAGE CODE
3 PLC ± 0.15		3.575 GRAMS	A3	00779
4 PLC ± -		CUSTOMER DRAWING	DRAWING NO	RESTRICTED TO
ANGLES ± 3'			C=2041372	
MATERIAL SEE NOTE	FINISH SEE NOTE	SCALE	SHEET	REV
			1 OF 4	C2

4

3

2

1

THIS DRAWING IS UNPUBLISHED.

RELEASED FOR PUBLICATION

© COPYRIGHT 2010

BY TYCO ELECTRONICS CORPORATION.

ALL RIGHTS RESERVED.

LOC DW

DIST

REVISIONS

P	LTR	DESCRIPTION	DATE	DWN	APVD
		SEE SHEET 1.			

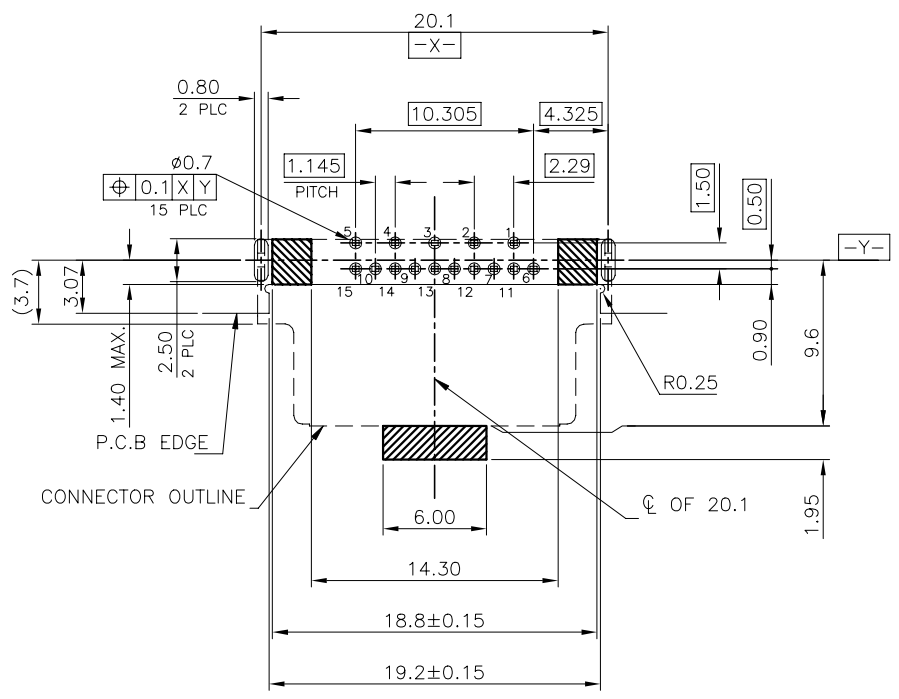
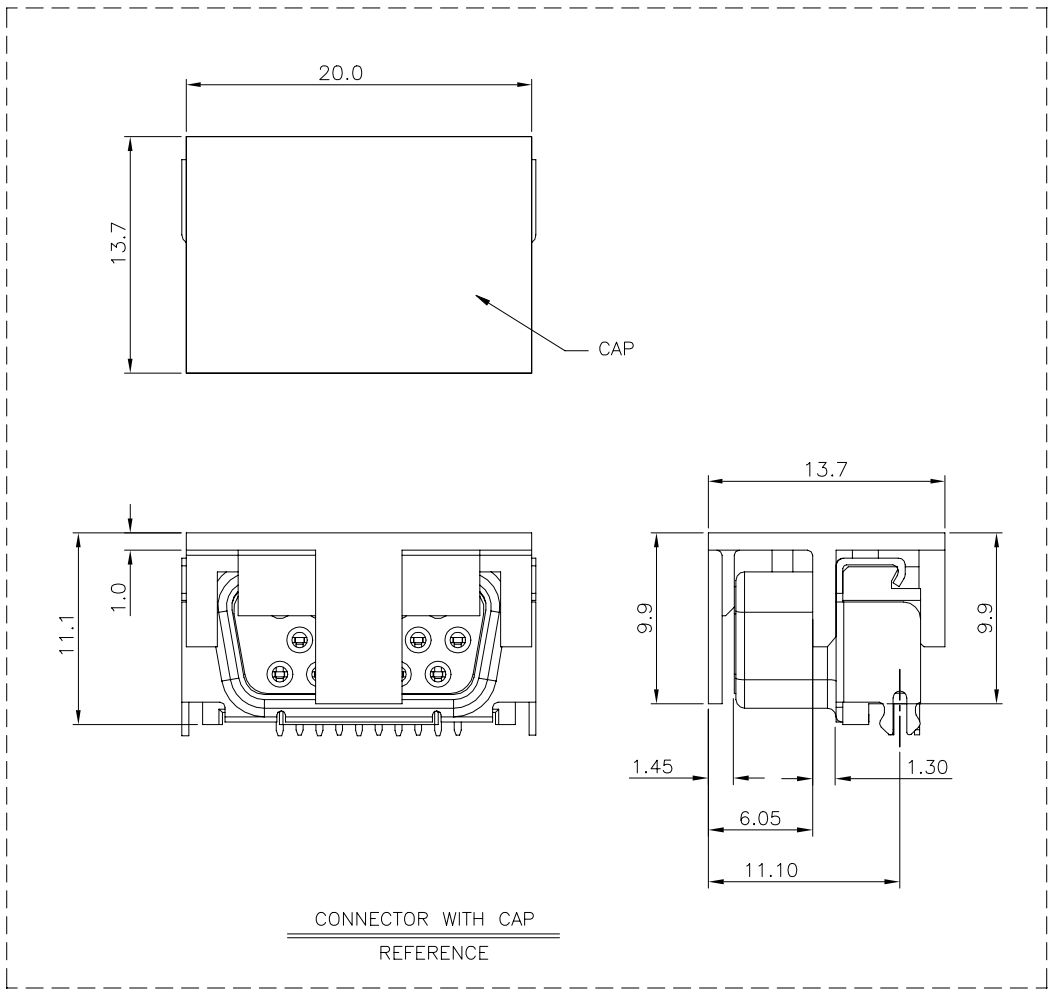

PCB THICKNESS : 1.2mm, TOLERANCE: ±0.03  
 ▨ KEEP OUT AREA FOR CAP STAND AREA  
 ▩ KEEP OUT FOR CONNECTOR STAND AREA

THIS DRAWING IS A CONTROLLED DOCUMENT.		DWN		TE Connectivity	
DIMENSIONS: mm		CHK			
TOLERANCES UNLESS OTHERWISE SPECIFIED:		APVD		NAME	
0 PLC ± - 1 PLC ± - 2 PLC ± - 3 PLC ± - 4 PLC ± - ANGLES ± -		PRODUCT SPEC		D-SUB CONNECTOR, RECEPTACLE ASSEMBLY, 15P, SLIM, RIGHT ANGLE, DIP TYPE, H=8.45mm	
MATERIAL		FINISH		DRAWING NO	
				A3 00779 C=2041372	
		WEIGHT		RESTRICTED TO	
		CUSTOMER DRAWING		SCALE	
				SHEET 2 OF 4	
				REV C2	

THIS DRAWING IS UNPUBLISHED. RELEASED FOR PUBLICATION  
 © COPYRIGHT 2010 BY TYCO ELECTRONICS CORPORATION. ALL RIGHTS RESERVED.

LOC	DIST	REVISIONS			
P	LTR	DESCRIPTION	DATE	DWN	APVD
DW		SEE SHEET 1.			

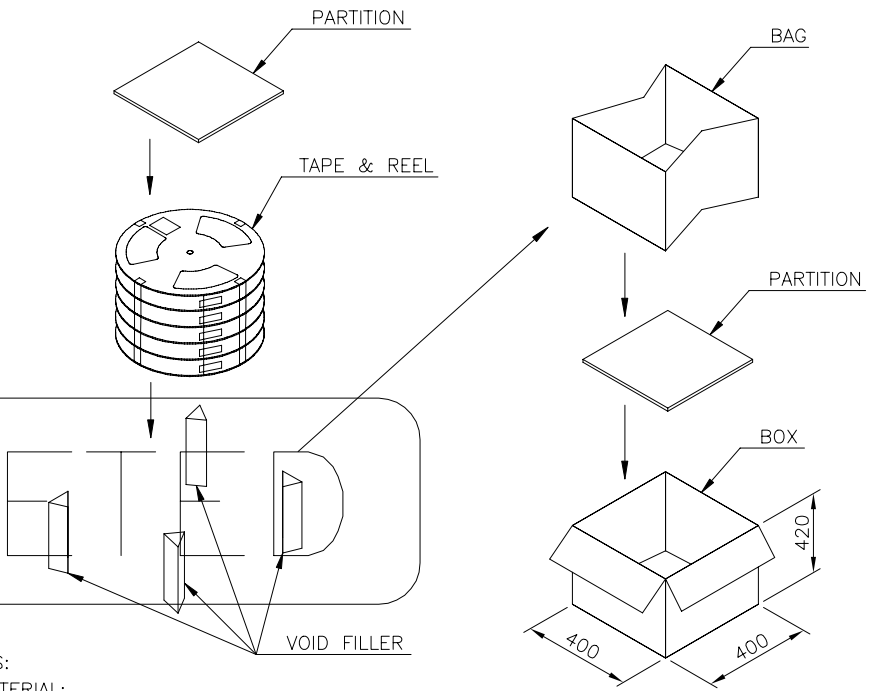
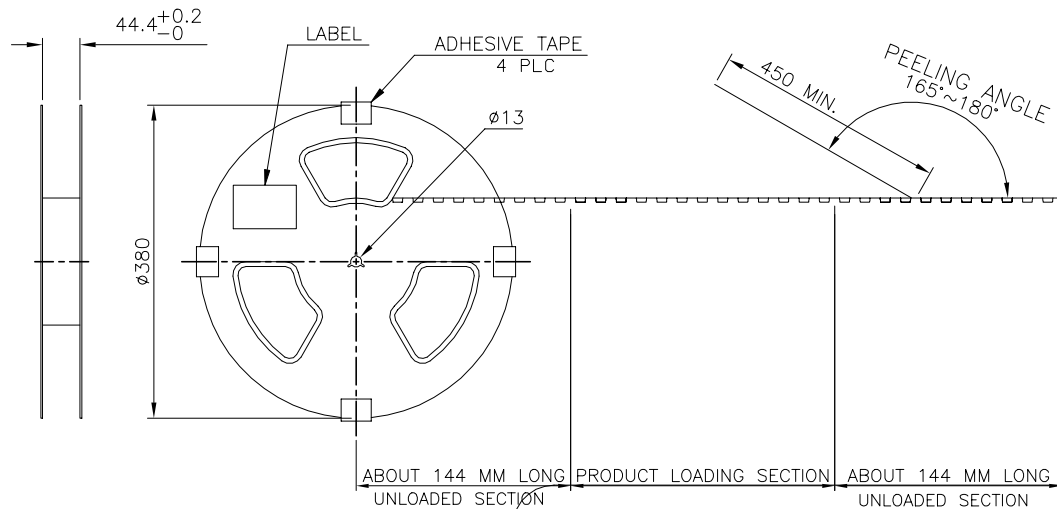

**SOLE MOUNTED**

PULL OUT DIRECTION

$\phi 2.0$  EMBOSS MARK IS INSIDE

$\phi 1.5^{+0.1}$ /<sub>-0</sub>

- NOTES:
- MATERIAL:  
 CARRIER TAPE: PS.  
 COVER TAPE: PET.  
 REEL: PS.  
 SHIPPING BOX: CORRUGATED FIBERBOARD.
  - PEELING RESISTANCE : 10gf~130gf
  - PEELING SPEED : 300mm/MINUTE

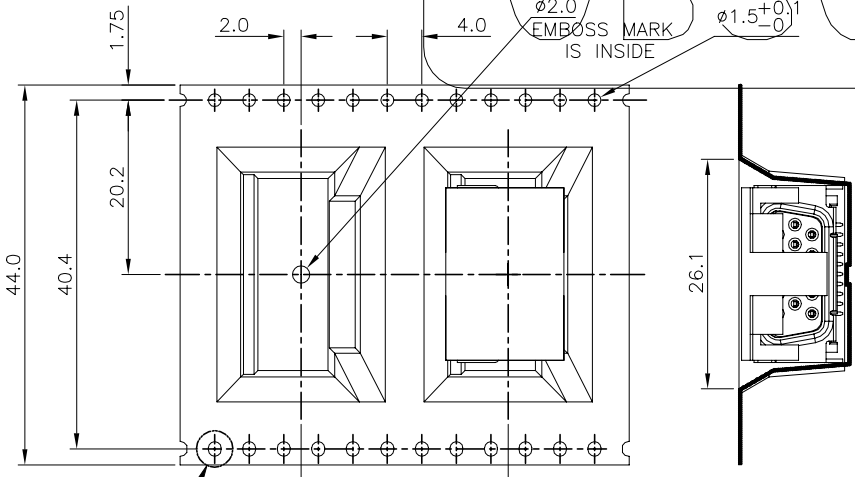

OBSELETE	12.25 KG	8.87 KG	310	8	2480	<del>2041372</del>
	GROSS WEIGHT	NET WEIGHT	PCS/ REEL	REELS/ BOX	PCS/ BOX	PART NUMBER

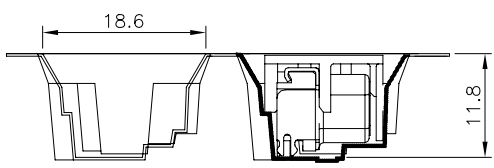
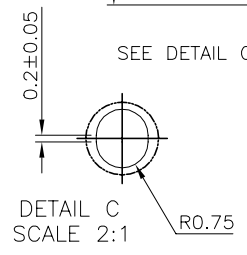

THIS DRAWING IS A CONTROLLED DOCUMENT.

DIMENSIONS: mm	TOLERANCES UNLESS OTHERWISE SPECIFIED:	DWN	TE Connectivity	
	0 PLC ±	CHK	NAME	
	1 PLC ±	APVD	D-SUB CONNECTOR, RECEPTACLE ASSEMBLY, 15P, SLIM, RIGHT ANGLE, DIP TYPE, H=8.45mm	
	2 PLC ±	PRODUCT SPEC	SIZE	CAGE CODE
	3 PLC ±	APPLICATION SPEC	A3	00779
	4 PLC ±	WEIGHT	DRAWING NO	RESTRICTED TO
	ANGLES ±	CUSTOMER DRAWING	C=2041372	
MATERIAL	FINISH	SCALE	SHEET	REV
			3 OF 4	C2

THIS DRAWING IS UNPUBLISHED. RELEASED FOR PUBLICATION  
 © COPYRIGHT 2010 BY TYCO ELECTRONICS CORPORATION. ALL RIGHTS RESERVED.

LOC	DIST	REVISIONS			
P	LTR	DESCRIPTION	DATE	DWN	APVD
DW		SEE SHEET 1.			

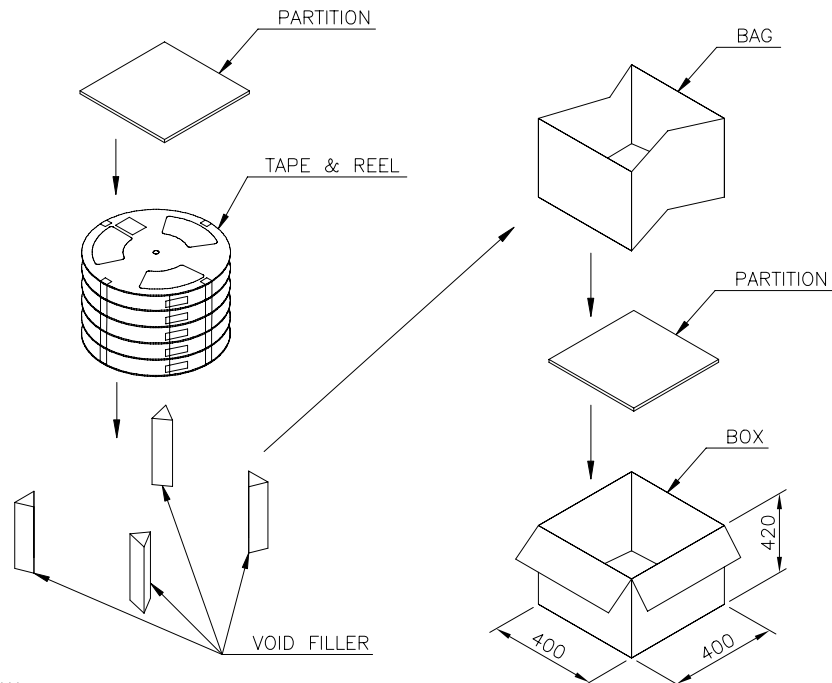
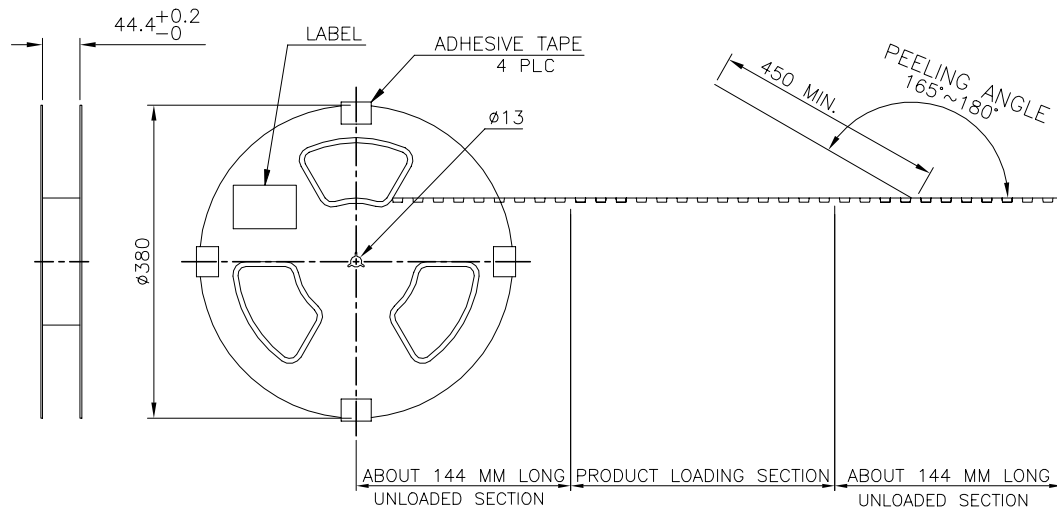

PULL OUT DIRECTION

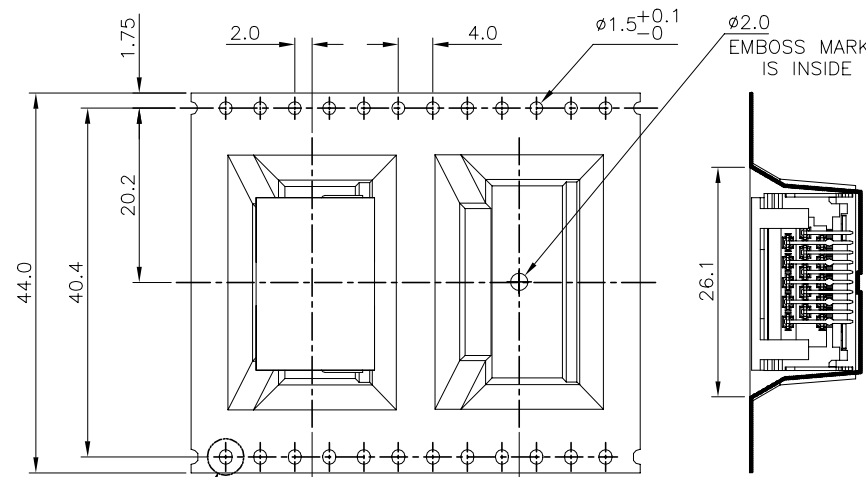

- NOTES:
- MATERIAL:  
 CARRIER TAPE: PS.  
 COVER TAPE: PET.  
 REEL: PS.  
 SHIPPING BOX: CORRUGATED FIBERBOARD.
  - PEELING RESISTANCE : 10gf~130gf
  - PEELING SPEED : 300mm/MINUTE

12.25 KG	8.87 KG	310	8	2480	2041372-2
GROSS WEIGHT	NET WEIGHT	PCS/ REEL	REELS/ BOX	PCS/ BOX	PART NUMBER

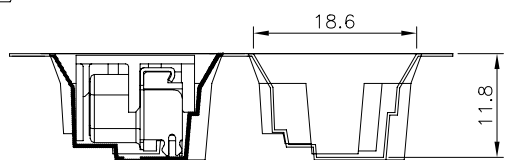
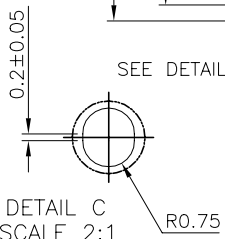

THIS DRAWING IS A CONTROLLED DOCUMENT.

DIMENSIONS: mm	TOLERANCES UNLESS OTHERWISE SPECIFIED:	DWN	TE Connectivity	
	0 PLC ± -	CHK	NAME	
	1 PLC ± -	APVD	D-SUB CONNECTOR, RECEPTACLE ASSEMBLY, 15P, SLIM, RIGHT ANGLE, DIP TYPE, H=8.45mm	
	2 PLC ± -	PRODUCT SPEC	SIZE	CAGE CODE
	3 PLC ± -	APPLICATION SPEC	A3	00779
	4 PLC ± -	WEIGHT	DRAWING NO	RESTRICTED TO
	ANGLES ± -	CUSTOMER DRAWING	C=2041372	
MATERIAL	FINISH	SCALE	SHEET	REV
			4 OF 4	C2