

GN 235

Zinc Die-Cast / Stainless Steel

Hinges

Adjustable



JWWINCO
A Ganter Company

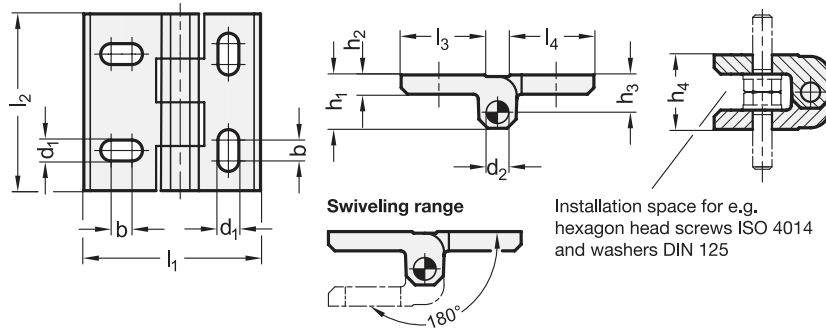

Swiveling range

Installation space for e.g. hexagon head screws ISO 4014 and washers DIN 125



Metric

SS Stainless Steel

4 Type

- H** Vertical slots
- B** Horizontal slots
- HB** Horizontal and vertical slots
- D** With through holes
- DH** With through holes and vertical slots
- DB** With through holes and horizontal slots

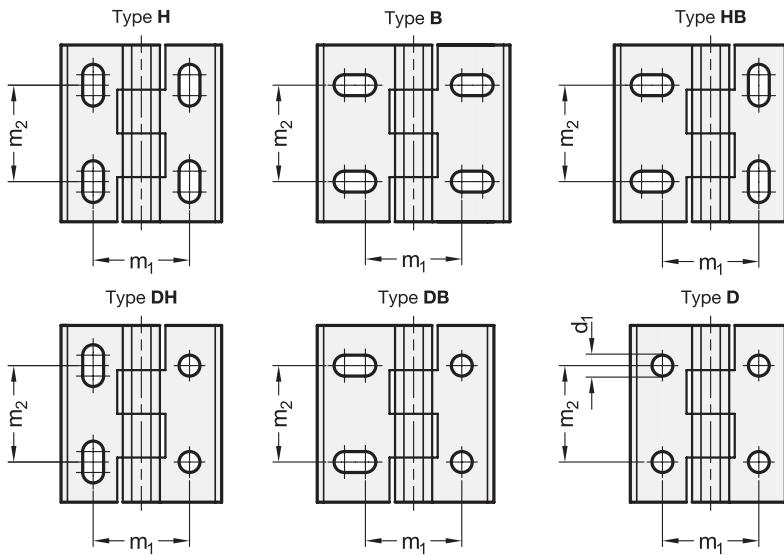

Metric table

2

3

Dimensions in: millimeters - inches

l ₁			l ₂	b	d ₁	d ₂	h ₁	h ₂	h ₃	h ₄	l ₃	l ₄		m ₁	m ₂	
Type D, DH, H	Type DB, HB	Type B										Type D, DH, H	Type DB, HB, B			Type D, DH, H, DB, HB
40 1.57	45 1.77	50 1.97	45 1.77	5.3 0.21	5.3 0.21	4 0.16	13 0.51	5 0.20	9.5 0.37	19 0.75	16 0.63	21 0.83	16 0.63	21 0.83	25 0.98	25 0.98
50 1.97	55 2.17	60 2.36	55 2.17	6.5 0.26	6.5 0.26	6 0.24	16.6 0.65	6 0.24	11.6 0.46	23.2 0.91	21 0.83	26 1.02	21 0.83	26 1.02	30 1.18	30 1.18
60 2.36	68 2.68	76 2.99	65 2.56	8.3 0.33	8.3 0.33	8 0.31	21.4 0.84	8 0.31	14.9 0.59	29.8 1.17	26 1.02	33.5 1.32	26 1.02	33.5 1.32	36 1.42	36 1.42

Specification

1

5

- Body
Zinc die-cast **ZD**
Powder coated
Black, RAL 9005, textured finish **SW**
Silver, RAL 9006, textured finish **SR**
- Stainless steel AISI CF-8 **NI**
Matte shot-blasted finish **GS**
- Pin
Stainless steel AISI 316Ti
- Load Rating Information → page 2088
- Stainless Steel Characteristics → page 2143
- RoHS compliant

Information

GN 235 hinges are adjustable vertically or horizontally along the slots, depending on the design, and are fastened with hexagon head, oval head or socket cap screws with a low head.

Sufficient space (installation space) is available for screw heads (with low heads) and washers, which allows the hinges to be opened the full range of 180°.

The hinge drill pattern corresponds with that of the GN 237 hinge family, which allows the hinges to be exchangeable.

see also...

- List of Hinge Types → page 1324
- Hinges GN 237 (Non Lift-Off) → page 1330

Accessory

- Spacer plates GN 2370 → page 1380
- Spacer plates with tapped holes GN 2372 → page 1381

How to order

GN 235-ZD-45-45-DB-SR

- 1 Material
- 2 Width l₁
- 3 Length l₂
- 4 Type
- 5 Finish

3.1
3.2
3.3
3.4
3.5
3.6
3.7
3.8
3.9
3.10