

MENSCH™



Microcomputer

WDC reserves the right to make changes at any time without notice in order to improve design and supply the best possible product. Information contained herein is provided gratuitously and without liability, to any user. Reasonable efforts have been made to verify the accuracy of the information but no guarantee whatsoever is given as to the accuracy or as to its applicability to particular uses. In every instance, it must be the responsibility of the user to determine the suitability of the products for each application. WDC products are not authorized for use as critical components in life support devices or systems. Nothing contained herein shall be construed as a recommendation to use any product in violation of existing patents or other rights of third parties. The sale of any WDC product is subject to all WDC Terms and Conditions of Sales and Sales Policies, copies of which are available upon request.

Copyright (C) 1978-2019 by The Western Design Center, Inc. All rights reserved, including the right of reproduction in whole or in part in any form.



DOCUMENT REVISION HISTORY

Version	Date	Author	Description
1.0	17-Mar-03	David Gray and Bill Mensch	Initial Document Entry
1.1	17-Mar-05/06	David Gray and Bill Mensch	Page 1 Microcomputer Datasheet changed to Microcomputer, Schematic page location changed, Internal Memory Map added, Header updated, Expansion Connectors table centered and Revision History resized.
1.2	17-Mar-13	Bill Mensch	Updated Internal Memory Map on page 9.
1.3	17-April-08	Bill Mensch and David Gray	Added Internal RAM Memory Map
1.4	17-July-31	Bill Mensch and David Gray	Updated Internal RAM Memory Map
1.5	19-Oct-16	David Gray	Correct J5 Pinout



Contents

DOCUMENT REVISION HISTORY..... 2

Introduction 4

Features 5

1.1 Feature List..... 5

1.2 Functional Block Diagram 5

1.3 Board Diagram 6

1.4 Schematic..... 7

1.5 W65C265S 16MB System Memory Map..... 8

1.6 W65C265S Internal On-Chip Memory Map 9

1.7 Internal User SRAM Memory Map..... 10

1.8 Expansion Connectors..... 11

1.9 8 LEDs..... 12

Connector Descriptions..... 12

2.1 TGx Connector (J1)..... 12

2.2 Control Connector (J2)..... 12

2.3 Left IO Connector – P2x/P50-P53/P60-P63 (J3)..... 12

2.4 Right IO Connector – P0x/P1x (J4) 12

2.5 Serial Port (J5) 12

Notices and Ordering Information..... 13

3.1 FCC Compliance..... 13

3.2 Ordering Information 13



Introduction

The MENSCH™ microcomputer (Part No. W65C265QBX) is a small single board computer (SBC), 1.25" x 2.25", using the System on a Chip (SoC) W65C265S MCU. The W65C265S was invented and designed by Bill Mensch WDC's founder after he invented and designed the 65816 microprocessor.

As a recognized pioneer of the microprocessor industry. Mr. Mensch's twenty two patented inventions were/are used on the original Motorola 6800 Microprocessor Family, MOS Technology 6502 Microprocessor Family, and WDC's 65C02 and 65816 Microprocessor Families. As an electrical engineer, 1971 BSEE from The University of Arizona (UA), having taught graduate level classes at Arizona State University (ASU) on SOC design for five years, advisor to four university colleges of engineering for over two decades, the MENSCH™ was designed in hopes that it will attract learners to consider a career based on an Electrical and Computer Engineering (ECE) education, hardware and software engineering.

The MENSCH™ can be used to learn about all kinds of electronic components and all kinds of state-of-the-art programmable logic. Operating at 3.3 volts provides for easy connectivity with various state-of-the-art electronic components and modules such as sensors and actuators. Operating at 5.0 volts provides easy connectivity to 5.0 volts electronic components and modules.

Learning to code in Machine language, Assembly Language, and C language as well as learning to describe hardware with software using Verilog HDL for use in different types of FPGA boards from Altera/Intel, Lattice, Microsemi, and Xilinx already at colleges of engineering provides an excellent basis for a future as an engineer. Describing hardware with software supports further retargeting to low cost and high performance ASICs for high volume commercial use.

Exploring the fundamentals of Electrical and Computer Engineering (ECE) with the MENSCH™ provides a strong foundation for understanding of all kinds of electronics and computer technologies such as the x86 microprocessors from Intel, used on PCs and Macs, and ARM microprocessors, used in all kinds of Android Tablets and iOS and Android Smartphones.

The MENSCH™ has a simple connector arrangement that can be used as stand alone, plugged into a bread board or plugged into your own custom "daughterboard" for your favorite Maker project. The MENSCH™ has a built in operating system called a "Monitor". The Mensch Monitor™ interfaces through a USB cable providing power and development through all kinds of "Terminal Emulators" found in most computers, PCs, Macs, tablets, and Smartphones.

Features

1.1 Feature List

- W65C265S MCU operating at 3.6864 MHz
- Works at 3.3V or 5V (Cable not provided), giving access to a wider range of sensors, memories, FPGAs, etc.
- 2 – 18 pin connectors plug into standard breadboards for quick prototyping. Signals accessed are Ports P0x (A0-A7), P1x(A8-A15), P3x (D0-D7), Serial Ports S0 and S1
- 8 LEDs connected to P7x
- 1 x 4 pin Connector with PHI2, WEB, NMIB and IRQB signals for expansion.
- 1 x 4 pin Twin Tone Generator Connector (Driven by TG0/1)
- Serial Terminal Programming Interface Serial Port #3 (P66/P67/P56/P57) NOTE: Requires external FTDI FT232 or similar cable/board (not included)

1.2 Functional Block Diagram

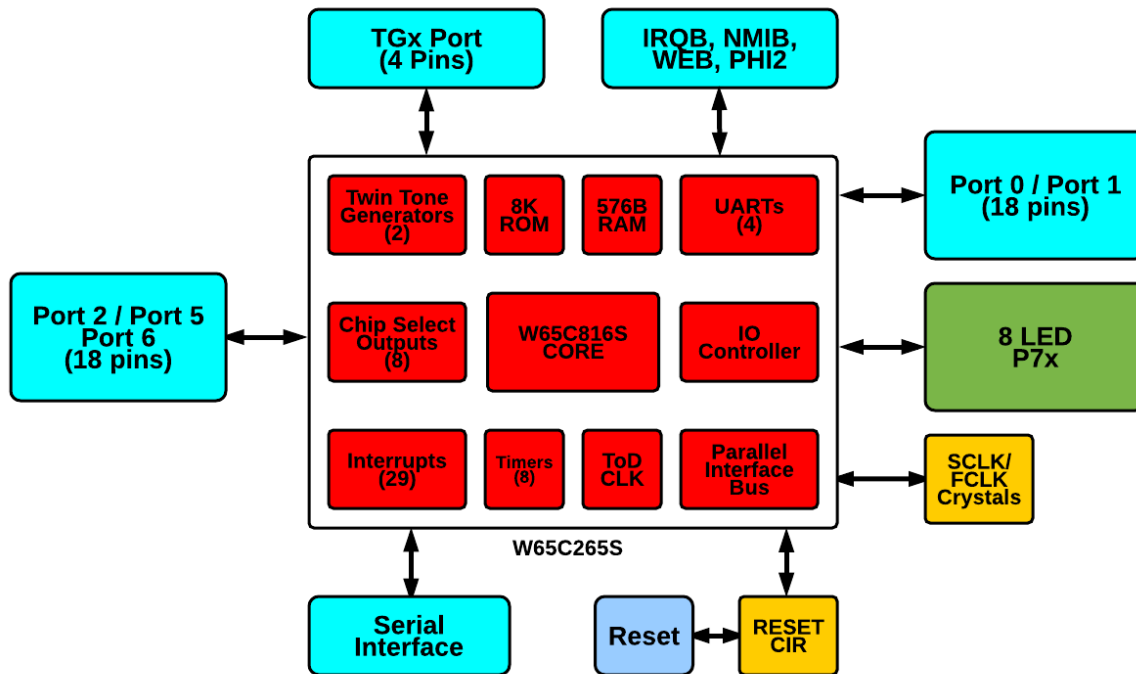

1.3 Board Diagram

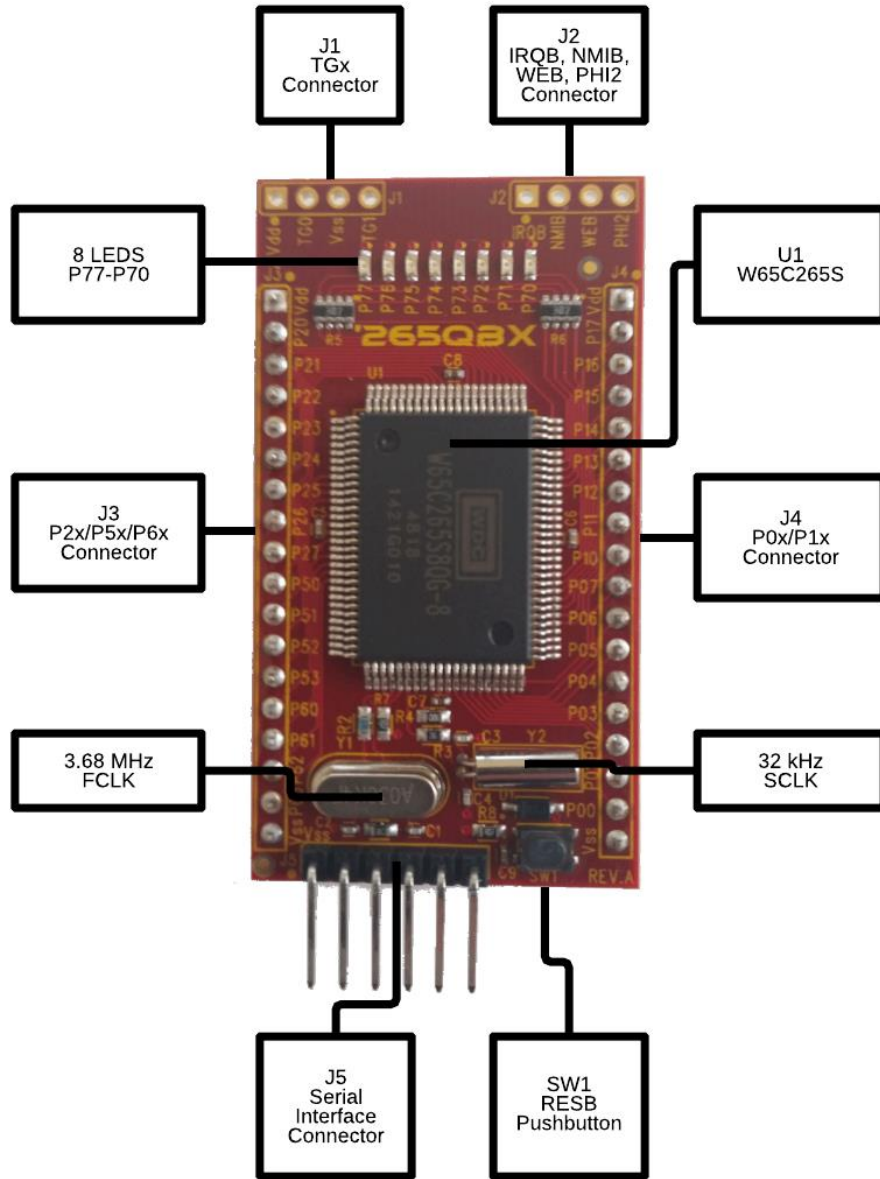

1.25" x 2.25" PCB

1.4 Schematic

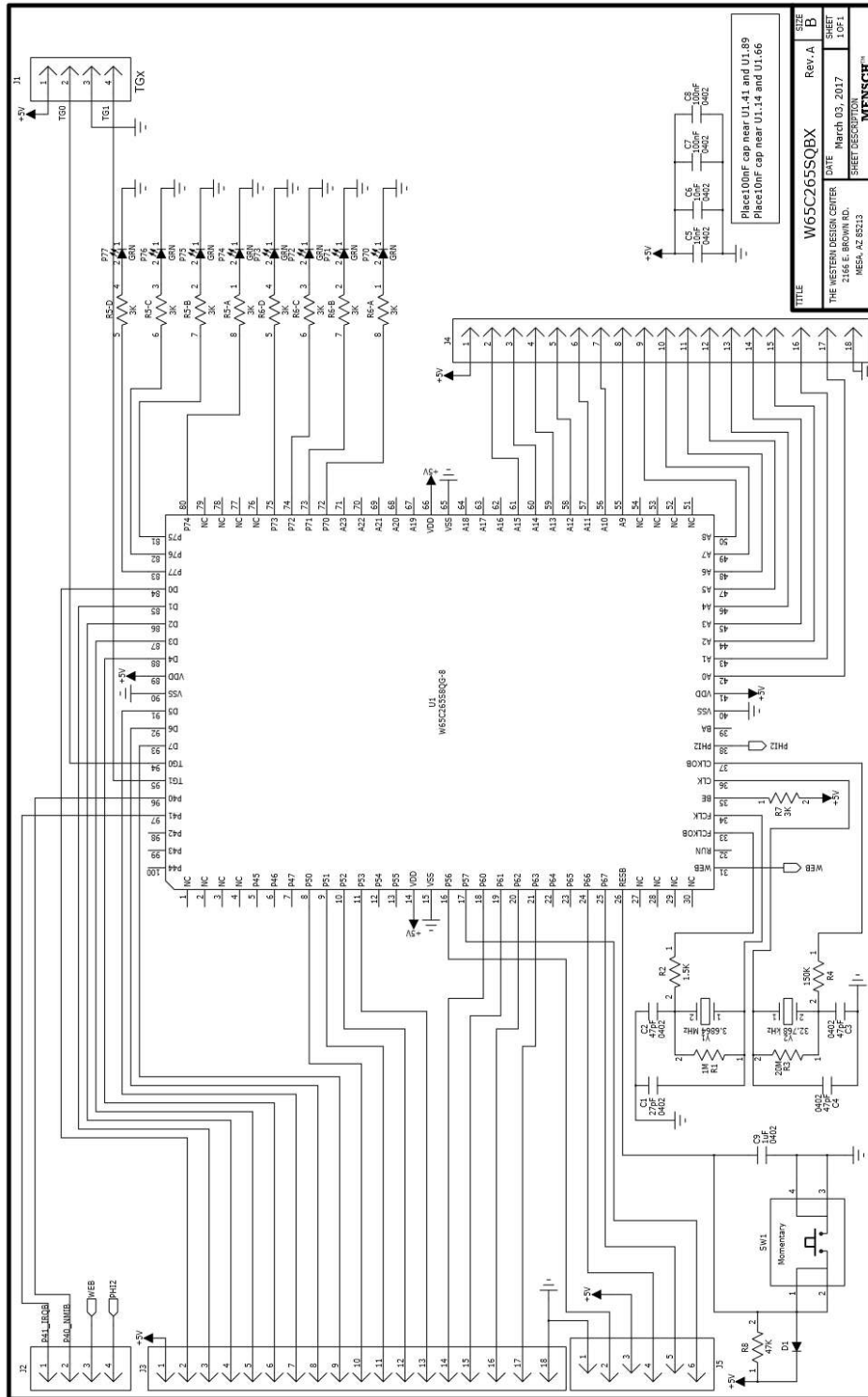

TITLE	W65C265SQBX	Rev. A	B
THE WESTERN DESIGN CENTER	2156 E. BROWN RD.	MEHA, AZ 85213	www.WDC65xx.com
DATE	March 02, 2017	SHEET	1 OF 1
SHEET DESCRIPTION		MENSCH™	

1.5 W65C265S 16MB System Memory Map

W65C265S 16MB System Memory Map				
Start	End	Size	Chip Select	Description
(C0)	(FF)	4 MB	CS7B	USER MEMORY (FOR EXPANSION)
(40)	(BF)	8 MB	CS6B	USER MEMORY (FOR EXPANSION)
(00)	(3F)	4 MB	CS5B	MEMORY <i>See Note 2</i>
(00)E000	(00)FFFF	8192 B	CS4B	ROM MEMORY (<i>Note 1</i>)
(00)8000	(00)DEFF	24320 B		ROM MEMORY (<i>Note 1</i>)
(00)0200	(00)7FFF	32256	CS3B	Cache Memory <i>See Note 3</i>
(00)FF00	(00)FFFF	256 B	CS2B	On Chip Interrupt Vectors
(00)E000	(00)FEFF	7936 B		On-Chip ROM
(00)DF80	(00)DFBF	64 B		On-Chip RAM
(00)DF70	(00)DF7F	16 B		On-Chip Comm. Registers
(00)DF50	(00)DF6F	32 B		On-Chip Timer Registers
(00)DF40	(00)DF4F	16 B		On-Chip Control Registers
(00)DF20	(00)DF27	8 B		On-Chip IO Registers
(00)DF00	(00)DF07	8 B		On-Chip IO Registers
(00)0000	(00)01FF	512 B		On-Chip RAM
(00)DFC0	0xDFFF	64 B		CS1B
(00)DF00	0xDF1F	32 B	CS0B	External Chip Select 0 (P70) <i>See Note 4</i>

Note 1 - When on-chip 8K bytes of ROM are enabled:

- a.) Addresses (00)E000-FFFF will not appear in CS4B chip select decode.
- b.) On Chip addresses (00)DF00-DFFF never appear in CS4B or CS5B chip select decode.

Note 2 - When on-chip ROM, CS3B and/or CS4B are enabled:

- a.) CS5B decode is reduced by the addresses used by same.
- b.) CS0B and CS1B address space never appears in CS2B, CS4B or CS5B decoded space.

Note 3 - When SSCR2 is "0" (internal RAM), then CS3B is active for addresses (00)0200-7FFF. When SSCR2 is "1" (external RAM), then CS3B is active for addresses (00)0000-7FFF.

Note 4 - CS0B is inactive when 00DF00-00DF07 are used for internal I/O register select (BCR0=0). When (BCR0=1) external memory bus is enabled CS0B is active for addresses 00DF00-00DF1F.

1.6 W65C265S Internal On-Chip Memory Map

See the [W65C265S Datasheet](#) for more details. Also, the demo code has a complete listing of labels for each of the register address locations for ease of coding in Assembly Language.

<i>Start</i>	<i>End</i>	<i>Size</i>	<i>Description</i>
(00)FF00	(00)FFFF	256B	Interrupt Vectors
(00)E000	(00)FEFF	7936B	MENSCH™ Monitor ROM
(00)DF80	(00)DFBF	64B	IO Page DF SRAM
(00)DF70	(00)DF7F	16B	Control Registers
(00)DF50	(00)DF6F	32B	UART Registers
(00)DF40	(00)DF4F	16B	Timer Registers
(00)DF27	(00)DF27	1B	Chip Select Register
(00)DF24	(00)DF26	3B	Data Direction Registers
(00)DF20	(00)DF23	4B	IO Registers
(00)DF04	(00)DF07	4B	Data Direction Registers
(00)DF00	(00)DF03	4B	IO Registers
(00)0100	(00)01FF	256B	65C02 Page One aka Stack Page SRAM
(00)0000	(00)00FF	256B	Page Zero SRAM

1.7 Internal User SRAM Memory Map

MENSCH™ Internal User SRAM																
Byte	0	1	2	3	4	5	6	7	8	9	A	B	C	D	E	F
Page 0	0	1	2	3	4	5	6	7	8	9	A	B	C	D	E	F
(00)0000	Y	Y	Y	Y	Y	Y	Y	Y	Y	Y	Y	Y	Y	Y	Y	Y
(00)0010	Y	Y	Y	Y	Y	Y	Y	N	N	N	N	N	N	N	N	N
(00)0020	Y	Y	Y	Y	Y	Y	Y	Y	Y	Y	Y	Y	Y	Y	Y	Y
(00)0030	Y	Y	Y	Y	Y	Y	Y	N	N	N	N	N	N	N	N	N
(00)0040	Y	Y	Y	N	N	N	N	N	N	N	N	N	N	N	N	N
(00)0050	Y	Y	Y	N	N	N	N	N	N	N	N	N	N	N	N	N
(00)0060	N	N	N	N	N	N	N	N	N	N	N	N	N	N	N	N
(00)0070	N	N	N	N	N	N	N	N	N	N	N	N	N	N	N	N
(00)0080	Y	Y	Y	Y	Y	N	Y	Y	Y	Y	Y	Y	Y	Y	Y	Y
(00)0090	Y	Y	Y	Y	Y	Y	Y	Y	Y	Y	Y	Y	Y	Y	Y	Y
(00)00A0	Y	Y	Y	Y	Y	Y	Y	Y	Y	Y	Y	Y	Y	Y	Y	Y
(00)00B0	N	N	N	N	N	N	Y	Y	Y	Y	Y	Y	Y	Y	Y	Y
(00)00C0	Y	Y	Y	Y	Y	Y	Y	Y	Y	Y	Y	Y	Y	Y	Y	Y
(00)00D0	Y	Y	Y	Y	Y	Y	Y	Y	Y	Y	Y	Y	Y	Y	Y	Y
(00)00E0	Y	Y	Y	Y	Y	Y	Y	Y	Y	Y	Y	Y	Y	Y	Y	Y
(00)00F0	Y	Y	Y	Y	Y	Y	Y	Y	Y	Y	Y	Y	Y	Y	Y	Y
Page 1	0	1	2	3	4	5	6	7	8	9	A	B	C	D	E	F
(00)0100	C	C	C	C	C	C	C	C	C	C	C	C	C	C	C	C
(00)0110	C	C	C	C	C	C	C	C	C	C	C	C	C	C	C	C
(00)0120	C	C	C	C	N	N	N	N	N	N	N	N	N	N	N	N
(00)0130	C	C	C	C	C	C	C	N	Y	Y	Y	Y	Y	Y	Y	Y
(00)0140	Y	Y	Y	Y	Y	Y	Y	Y	Y	Y	Y	Y	Y	Y	Y	Y
(00)0150	Y	Y	Y	Y	Y	N	N	N	N	N	N	N	N	N	N	N
(00)0160	N	Y	Y	Y	Y	Y	Y	Y	Y	Y	Y	Y	Y	Y	Y	Y
(00)0170	Y	Y	Y	Y	Y	Y	Y	Y	Y	Y	Y	Y	Y	Y	Y	Y
(00)0180	Y	Y	Y	Y	Y	Y	N	N	N	N	N	N	N	N	N	N
(00)0190	Y	Y	Y	Y	Y	N	N	N	N	N	N	N	N	N	N	N
(00)01A0	Y	Y	Y	Y	Y	Y	Y	Y	Y	Y	Y	Y	Y	Y	Y	Y
(00)01B0	Y	Y	Y	Y	Y	Y	Y	Y	Y	Y	Y	Y	Y	Y	Y	Y
(00)01C0	Y	Y	Y	Y	Y	Y	Y	Y	Y	Y	Y	Y	Y	Y	Y	Y
(00)01D0	Y	Y	Y	Y	Y	Y	N	Y	Y	Y	Y	Y	Y	N	N	N
(00)01E0	Y	Y	Y	Y	N	N	N	N	N	N	N	N	N	N	N	N
(00)01F0	N	N	N	N	N	N	N	N	N	N	N	N	N	N	N	N
Page DF	0	1	2	3	4	5	6	7	8	9	A	B	C	D	E	F
(00)DF80	Y	Y	Y	Y	Y	Y	Y	Y	Y	Y	Y	Y	Y	Y	Y	Y
(00)DF90	Y	Y	Y	Y	Y	N	Y	Y	Y	Y	Y	Y	Y	Y	Y	Y
(00)DFA0	Y	Y	Y	N	Y	Y	Y	Y	Y	Y	Y	Y	Y	Y	Y	Y
(00)DF80	Y	Y	Y	Y	Y	Y	N	N	Y	Y	Y	Y	Y	Y	Y	Y

Legend

These areas are open RAM locations

These areas should not be used.

These areas are for USER use, but are reset when the reset button is pushed.

1.8 Expansion Connectors

<i>J1 – TGx Connector</i>			
<i>Pin</i>	<i>Signal Name</i>	<i>Pin</i>	<i>Signal Name</i>
1	VDD	2	TG0
3	VSS	4	TG1

<i>J2 – Bus Control Connector</i>			
<i>Pin</i>	<i>Signal Name</i>	<i>Pin</i>	<i>Signal Name</i>
1	P41-IRQB	2	P40-NMIB
3	WEB	4	PHI2

<i>J3 –Left Expansion Connector</i>		<i>J4 –Right Expansion Connector</i>	
<i>Pin</i>	<i>Signal Name</i>	<i>Pin</i>	<i>Signal Name</i>
1	VDD	1	VDD
2	P20-D0	2	P17-A15
3	P21-D1	3	P16-A14
4	P22-D2	4	P15-A13
5	P23-D3	5	P14-A12
6	P24-D4	6	P13-A11
7	P25-D5	7	P12-A10
8	P26-D6	8	P11-A9
9	P27-D7	9	P10-A8
10	P50-DTRB0	10	P07-A7
11	P51-DSRB0	11	P06-A6
12	P52-DTRB1	12	P05-A5
13	P53-DSRB1	13	P04-A4
14	P60-RXD0	14	P03-A3
15	P61-TXD0	15	P02-A2
16	P62-RXD1	16	P01-A1
17	P63-TXD1	17	P00-A0
18	VSS	18	VSS

<i>J5 – UART Serial Connector</i>			
<i>Pin</i>	<i>Signal Name</i>	<i>Pin</i>	<i>Signal Name</i>
1	VSS	2	P56-DTRB3
3	VDD	4	P66-RXD3
5	P67-TXD3	6	P57-DSRB3

1.9 8 LEDs

The MENSCH™ has 8 LEDs connected to the Port 7 chip select signals. The LED furthest to the left is connected to P77. The LED furthest to the right is connected to P70. Each LED is labeled for the appropriate signal on the board.

Connector Descriptions

Following are descriptions of main board connectors. For Port pins coming from the W65C265S chip, careful review of the [W65C265S Datasheet](#) is recommended.

2.1 TGx Connector (J1)

The Twin Tone Generator outputs (TGx) are synthesized 16 step cosine waveform outputs. Each Tone Generator is comprised of a 16 bit timer and a 16 step divider circuit that selects the proper Digital to Analog (DA) output level. The enable bits for the tone generators are located in bits 1 and 2 of the BCR registers. Refer to the [W65C265S Datasheet](#) (Section 1.11) for detailed operation information.

2.2 Control Connector (J2)

4 Control lines (P41-IRQB, P40-NMIB, WEB, PHI2) for external expansion.

2.3 Left IO Connector – P2x/P50-P53/P60-P63 (J3)

The J3 Left Connector has 16 IO lines that are connector to the P20-P27, P50-P53, and P60-P63 signals. This gives the user either 16 general purpose IO lines, the Data bus (P20-P27), or 2 serial UART ports (the signals are on both P5x and P6x). See Section 1.5 for connection information.

2.4 Right IO Connector – P0x/P1x (J4)

The J4 Right Connector has 16 IO lines that are connector to the P00-P07, and P10-P17 signals. This gives the user either 16 general purpose IO lines or the A0-A15 Address Bus of the W65C265S. See Section 1.5 for connection information.

2.5 Serial Port (J5)

The Serial Port connector is dual purpose. It is through this connector that you will generally power the board if you are hooking the board up to a PC, smartphone, etc. for serial communications. In addition to the power, the J5 has the signals from UART3. The built-in monitor has software to communicate through this port to a terminal. See Section 1.5 for connection information.



Notices and Ordering Information

3.1 FCC Compliance

The Western Design Center, Inc. (WDC) provides the enclosed product under the following conditions: This board is intended for use for Engineering Development or Evaluation Purposes ONLY and is not considered by WDC to be a finished consumer product. This board should be handled with caution using good electronics handling practices. This board is compliant per RoHS/Green directives. It does not fall within the scope of directives such as FCC, CE, and UL. It generates uses and can radiate radio frequency energy and has not been tested for compliance with the limits of computing devices pursuant to part 15 of FCC rules.

3.2 Ordering Information

The W65C265QBX is available from WDC Direct and our distribution partners. For information please visit: <http://wdc65xx.com/where-to-buy/>