



American Opto Plus LED Corp.

L196L-NWC-L

1.6 x 0.8 x 0.4 mm White SMD LED

PACKAGE OUTLINES

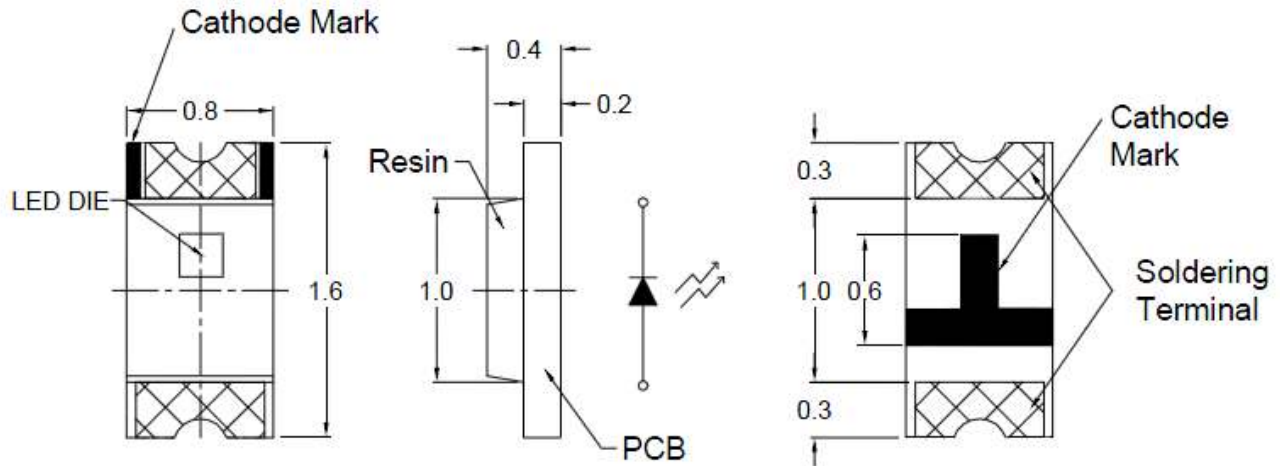

RECOMMEND PAD LAYOUT

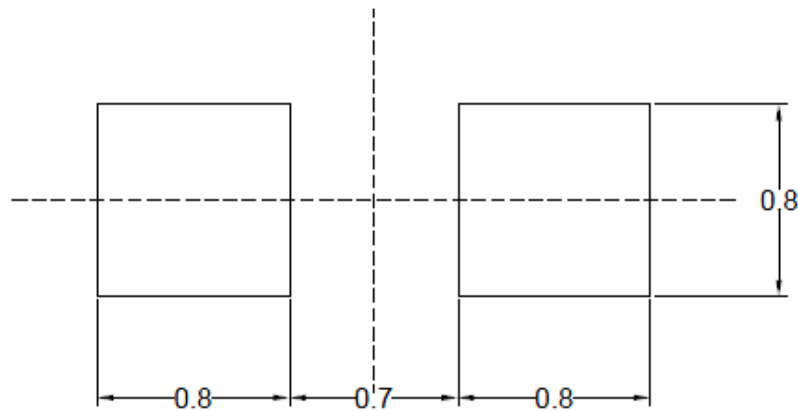

NOTES:

1. All dimensions are in millimeters tolerance is ± 0.1 mm unless otherwise noted, Angle $\pm 0.5^\circ$ / Unit=mm.
2. Specifications are subject to change without notice.

Part Number	Material	Lens Color	
		Emitted	Lens
L196L-NWC-L	InGan/GaN	White	Yellow Diffused



American Opto Plus LED Corp.

L196L-NWC-L

1.6 x 0.8 x 0.4 mm White SMD LED

ABSOLUTE MAXIMUM RATINGS

(Ta=25°C)

Parameter	Symbol	Ratings	Unit
Power Dissipation	Pd	96	mW
Peak Forward Current Duty 1/10@10KHz	I _{fp}	100	mA
Forward Current	I _f	30	mA
Reverse Current @ 5V	I _r	50	μA
Electrostatic Discharge	ESD	500	V
Operating temperature range	T _{opr}	-20~+85	°C
Storage temperature range	T _{stg}	-30~+100	°C
Soldering Temperature	T _{sol}	Max 260°C for 5 sec Max	

OPTICAL-ELECTRICAL CHARACTERISTICS

(Ta=25°C)

Parameter	Symbol	Test Condition	Min	Typ	Max	Unit
Luminous Intensity	I _v	I _F =5mA	80	150	--	mcd
Chromaticity Coordinates	X		0.21	--	0.35	--
	Y		0.15	--	0.4	--
Forward Voltage	V _f		2.6	--	3.2	V
Viewing angle	2θ ½		--	130	--	Deg

- Note: 1. The forward voltage data did not include ±0.1V testing tolerance.
2. The luminous intensity data did not include ±15% testing tolerance.



American Opto Plus LED Corp.

L196L-NWC-L

1.6 x 0.8 x 0.4 mm White SMD LED

LUMINOUS INTENSITY BIN TABLE

BIN CODE	Iv(mcd) @ 5mA	
	Min	Max
Q	80	125
R	125	200
S	200	320
T	320	500

FORWARD VOLTAGE BIN TABLE

BIN CODE	Vf(V) @ 5mA	
	Min	Max
1	2.6	2.7
2	2.7	2.8
3	2.8	2.9
4	2.9	3.0
5	3.0	3.1
6	3.1	3.2



American Opto Plus LED Corp.

L196L-NWC-L

1.6 x 0.8 x 0.4 mm White SMD LED

CHROMATICITY COORDINATES SPECIFICATIONS FOR BIN GRADING

BIN	X	Y	BIN	X	Y	BIN	X	Y
A1	0.21	0.190	B1	0.26	0.265	C1	0.31	0.340
	0.21	0.150		0.26	0.225		0.31	0.300
	0.22	0.165		0.27	0.240		0.32	0.315
	0.22	0.205		0.27	0.280		0.32	0.355
A2	0.22	0.205	B2	0.27	0.280	C2	0.32	0.355
	0.22	0.165		0.27	0.240		0.32	0.315
	0.23	0.180		0.28	0.255		0.33	0.330
	0.23	0.220		0.28	0.295		0.33	0.370
A3	0.23	0.220	B3	0.28	0.295	C3	0.33	0.370
	0.23	0.180		0.28	0.255		0.33	0.330
	0.24	0.195		0.29	0.270		0.34	0.345
	0.24	0.235		0.29	0.310		0.34	0.385
A4	0.24	0.235	B4	0.29	0.310	C4	0.34	0.385
	0.24	0.195		0.29	0.270		0.34	0.345
	0.25	0.210		0.30	0.285		0.35	0.360
	0.25	0.250		0.30	0.325		0.35	0.400
A5	0.25	0.250	B5	0.30	0.325			
	0.25	0.210		0.30	0.285			
	0.26	0.225		0.31	0.300			
	0.26	0.265		0.31	0.340			



American Opto Plus LED Corp.

L196L-NWC-L

1.6 x 0.8 x 0.4 mm White SMD LED

CIE CHROMATICITY DIAGRAM

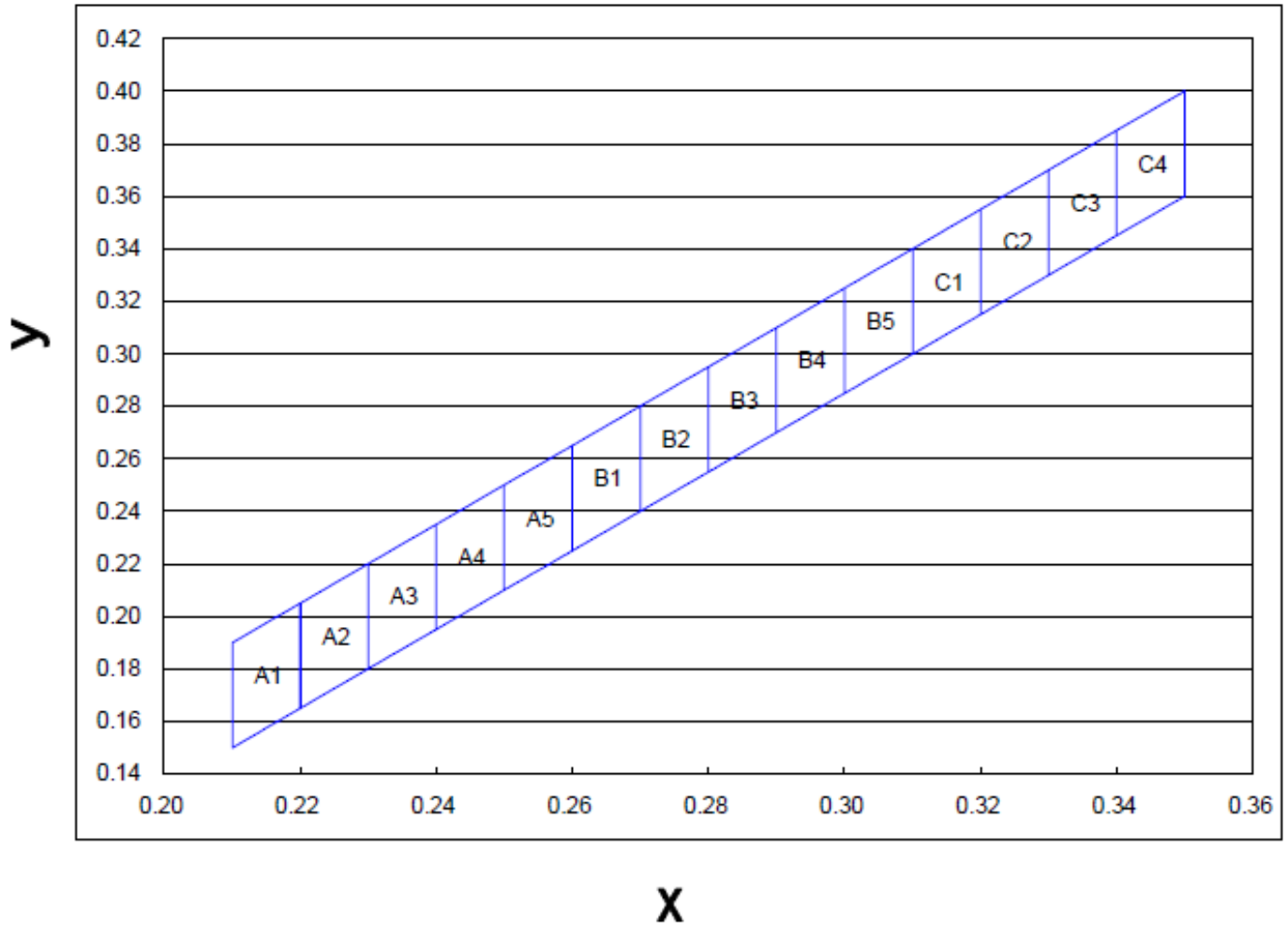



American Opto Plus LED Corp.

L196L-NWC-L

1.6 x 0.8 x 0.4 mm White SMD LED

TYPICAL ELECTRO-OPTICAL CHARACTERISTIC CURVES

Fig.1 Forward current vs. Forward Voltage

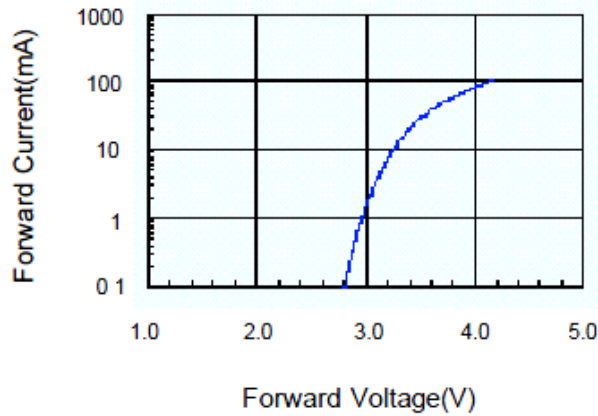

Fig.2 Relative Intensity vs. Forward Current

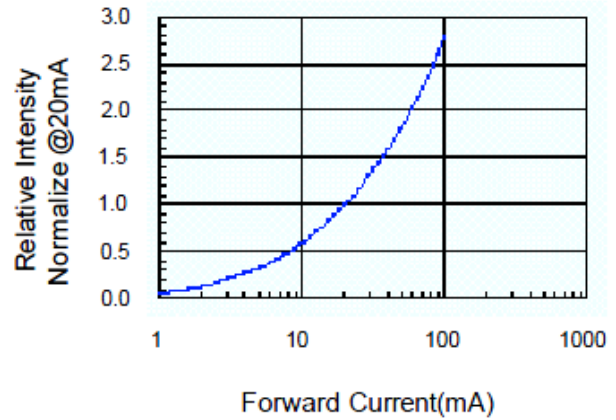

Fig.3 Forward Voltage vs. Temperature

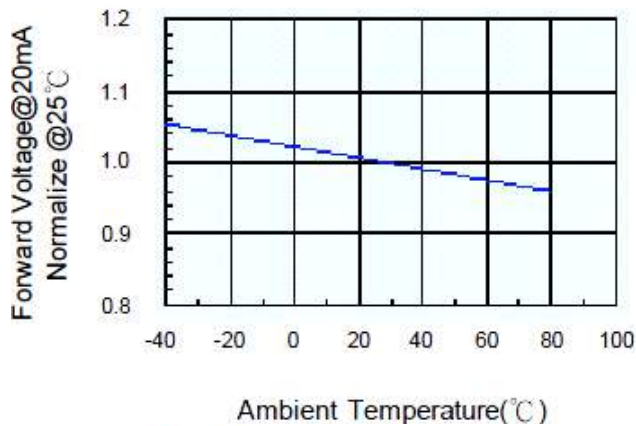

Fig.4 Relative Intensity vs. Temperature

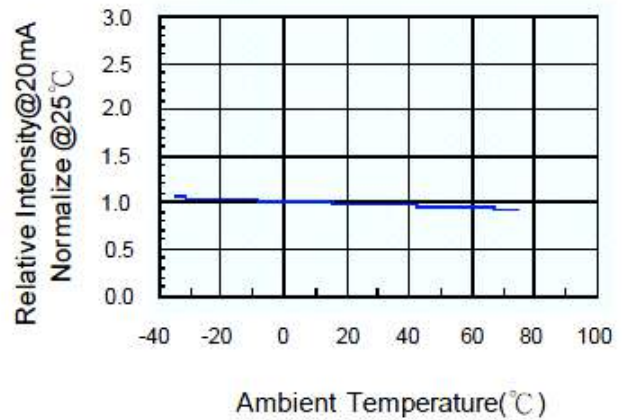

Fig.5 Luminous Spectrum (Ta=25°C)

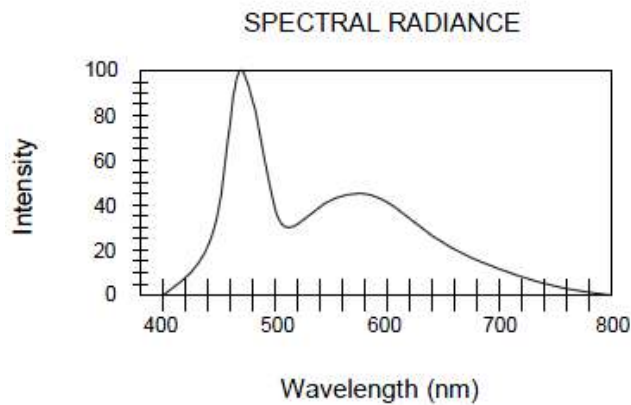
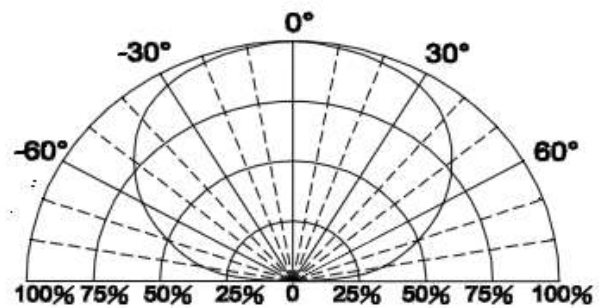

Fig.6 Directive Radiation





American Opto Plus LED Corp.

L196L-NWC-L

1.6 x 0.8 x 0.4 mm White SMD LED

CARRIER TAPE DIMENSION

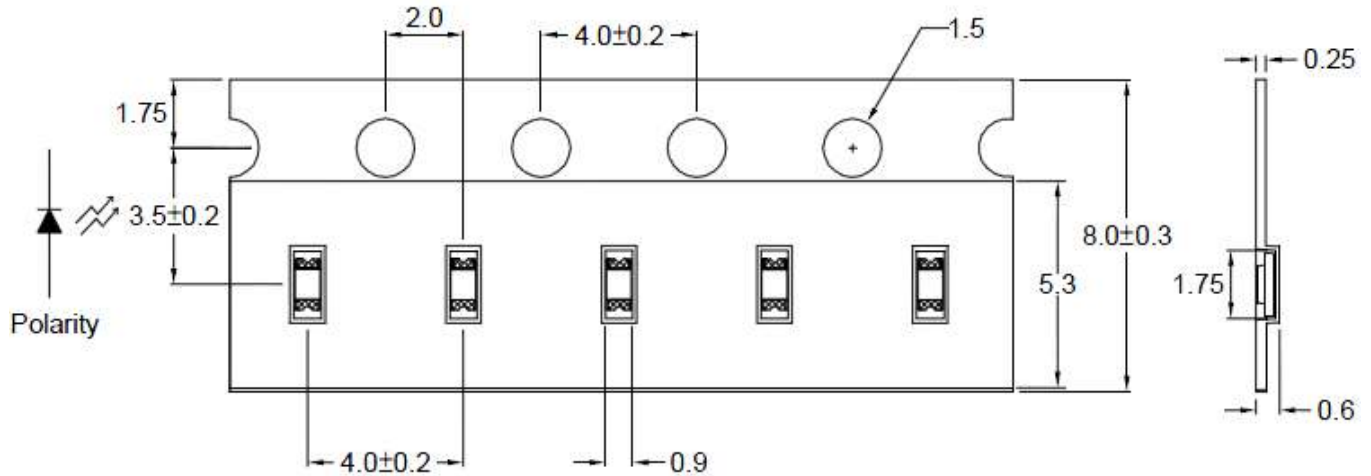

Note: The tolerances unless mentioned are ± 0.1 mm, Angle ± 0.5 ; Unit=mm

REEL DIMENSIONS

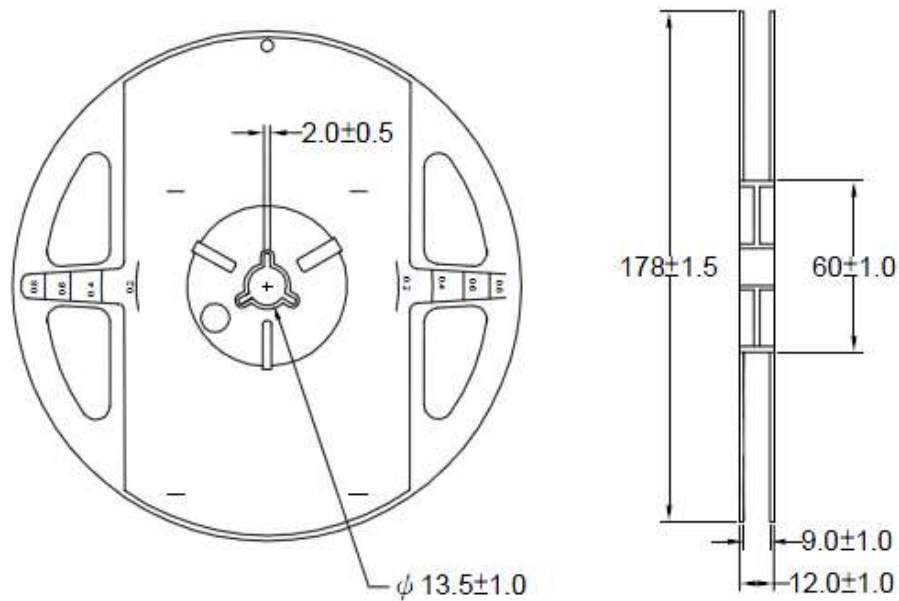

Notes:

1. 4000 pieces per reel.



American Opto Plus LED Corp.

L196L-NWC-L

1.6 x 0.8 x 0.4 mm White SMD LED

RECOMMENDED SOLDERING CONDITIONS

1. Hand Solder

Basic spec is $\leq 280^{\circ}\text{C}$ 3 sec one time only.

2. Wave Solder

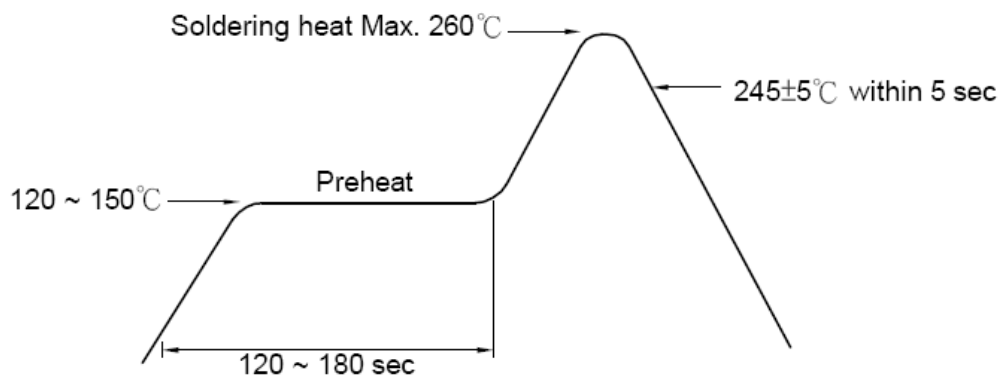

3. LEAD Reflow Solder

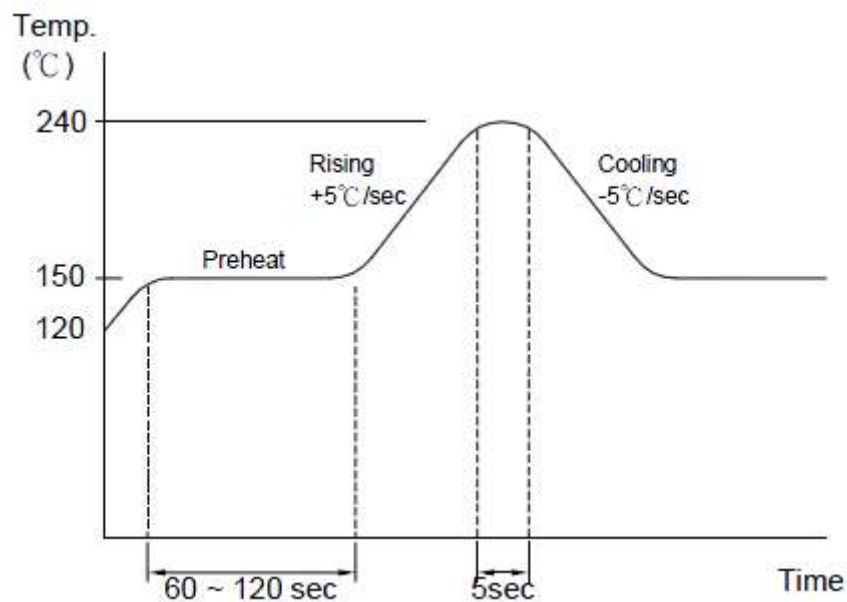



American Opto Plus LED Corp.

L196L-NWC-L

1.6 x 0.8 x 0.4 mm White SMD LED

4. PB-Free Reflow Solder

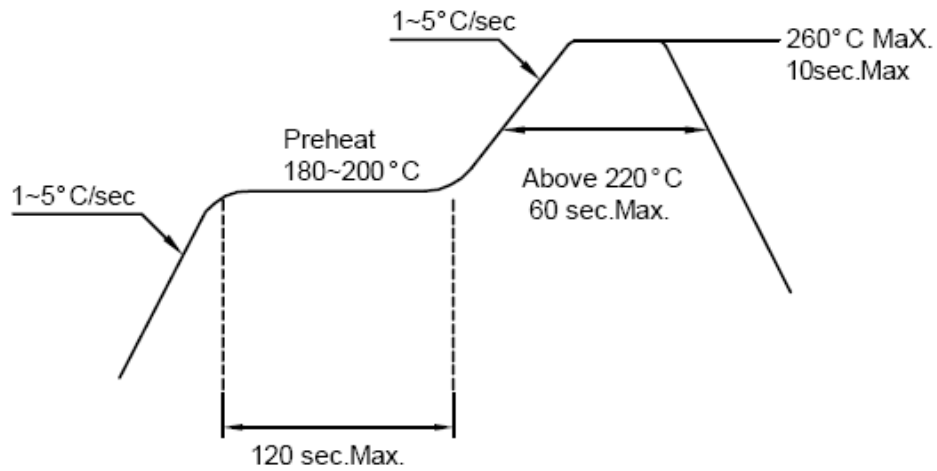

Notes:

1. Reflow soldering should not be done more than two times.
2. When soldering, do not put stress on the LEDs during heating.



American Opto Plus LED Corp.

L196L-NWC-L

1.6 x 0.8 x 0.4 mm White SMD LED

PRECAUTIONS FOR USE

Storage Time:

1. The operation of temperatures and RH are: 5°C~35°C, RH60%.
2. Once the package is opened, the products should be used within a week. Otherwise, they should be kept in a damp proof box with desiccating agent. Considering the tape life, we suggest our customers to use our products within a year (from production date).
3. If opened more than one week in an atmosphere 5°C~35°C, RH60%, they should be treated at 60°C±5°C for 15hrs.

Drive Method:

LED is a current operated device, and therefore, require some kind of current limiting incorporated into the driver circuit. This current limiting typically takes the form of a current limiting resistor placed in a series with the LED.

Consider worst case voltage variations that could occur across the current limiting resistor. The forward current should not be allowed to change by more than 40% of its desired value.

Circuit model A

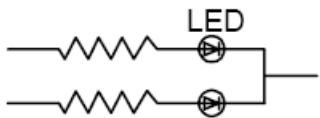

Circuit model B

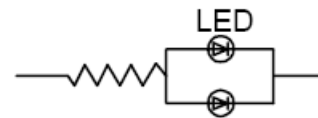

(A) Recommended circuit.

(B) The difference of brightness between LED could be found due to the VF-IF characteristics of LED.

Cleaning:

Use alcohol-based cleaning solvents such as isopropyl alcohol to clean the LED.

ESD(Electrostatic Discharge):

Static Electricity or power surge will damage the LED. Use of a conductive wrist band or anti-electrostatic glove is recommended when handling these LEDs. All devices and machinery must be properly grounded.



American Opto Plus LED Corp.

L196L-NWC-L

1.6 x 0.8 x 0.4 mm White SMD LED

RELIABILITY TEST:

Classification	Test Item	Test Conditions	Reference Standard
Endurance Test	Operating Life Test	1. Ta=under room temperature as per data sheet maximum rating 2. If=20mA 3. t=1000 hrs (-24hrs, +72hrs)	MIL-STD-750D:1026 MIL-STD-883D:1005 JIS C 7021:B-1
	High Temperature Storage Test	1. Ta=105°C±5°C 2. t=1000 hrs (-24hrs, +72hrs)	MIL-STD-883D:1008 JIS C 7021:B-10
	Low Temperature Storage Test	1. Ta=40°C±5°C 2. t=1000 hrs (-24hrs, +72hrs)	JIS C 7021:B-12
	High Temperature High Humidity Storage Test	1. Ta=65°C±5°C 2. RH=90%~95% 4. t=1000hrs±2hrs	MIL-STD-202F:103B JIS C 7021:B-11
	Special Operating Life Test	1. Ta = 70°C 2. If=20mA 3. 50000hrs (-24hrs, +72hrs)	Retain ≥ 70% of its luminance
Environmental Test	Thermal Shock Test	1. Ta=105°C±5°C & -40°C±5°C (10min) (10min) 2. Total 10 cycles	MIL-STD-202F:107D MIL-STD-750D:1051 MIL-STD-883D:1011
	Solderability Test	1. Tsol=235°C±5°C 2. Immersion time 2±0.5sec 3. Coverage ≥95% of the dipped surface	MIL-STD-202F:208D MIL-STD-750D:2026 MIL-STD-883D:2003 IED 68 PART 2-20 JIS C 7021:A-2
	Temperature Cycling	1. 105°C ~ 25°C ~ -55°C ~ 25°C 30 mins 5 mins 30 mins 5 mins 2. 10 cycles	MIL-STD-202F:107D MIL-STD-750D:1051 MIL-STD-883D:1010 JIS C 7021:A-4
	IR Reflow	1. T=260°C Max. 10 sec Max 2. 6 Min	MIL-STD-750D:2031.2 J-STD-020