



Features

- 35A switching capability.
- NO type and CO type are available
- Satisfy RoHS and ELV

Contact Capacity

Model	SARS
Max. continuous current ⁽¹⁾	35A
Max. switching current	connect (NO):150A ⁽²⁾ , disconnect(NO):35A
Max. switching voltage	see performance curve

Contact Data

Contact Voltage	Load Type		Contact Current(A)		duty factor		endurance (cycles)	contact material	test ambient temperature
			1C, 1A		ON S	OFF S			
			NO	NC					
14VDC	resistive	on	35	20	2	2	1x10 ⁵	AgSnO ₂	23°C
		off	35	20					
	lamp load	on	150	—	2	2	1x10 ⁵	AgSnO ₂	
		off	30	—					
	general	on	80	—	2	2	1x10 ⁵	AgSnO ₂	
		off	30	—					

Note: If the load condition is not in the table. Please contact SANYOU with load details to get more support

Characteristic Data

Contact material	Silver alloy	
contact voltage drop	200mv/at 10A (max)	
Operate time	10msec. Max.	
Release time ⁽³⁾	10msec. Max.	
Initial insulation resistance	100MΩ Min.(DC500V)	
Initial dielectric strength ⁽⁴⁾	Between open contacts : AC500V , 50/60Hz 1min.	
	Between coil and contact : AC500V , 50/60Hz 1min.	
Vibration resistance ⁽⁵⁾	10~25Hz 1.27mm double-amplitude	
	25~500Hz 98m/s ²	
Shock resistance	NO 20G/ NC 5G	
Endurance	Mechanical (at 10,800 ops./h)	1x10 ⁷
	Electrical	see contact parameter table
mechanical behavior	Cover retentivity : (pull and press) ≥200N	
	Terminals retentivity : (pull and press) ≥100N	
	Terminals bending stiffness : (all directios) ≥10N ⁽⁶⁾	
Ambient temperature	-40°C ~ +125°C (no condensation)	
Unit weight	Approx.17.5 g	

Note : (1) For the normally open contact , the measurement of the 100% rated voltage is applied to the coil
 (2) surge current in lamp load , 14VDC ;
 (3) Rated voltage step up to 0VDC , And measurement without coil suppression circuit ;
 (4) The leakage current is less than 1mA ;
 (5) When the excitation is excited,the opening time of the normally open contact is less than 1ms;when no excitation,the normally closed contact time is less than 1ms,at the same time,the normally open contact can not be closed ;
 (6) Test point for the distance 2mm from the end foot,when the test force is removed,the lead foot should be less than 0.5mm ;

Coil Data (at 20°C)

Nominal voltage (VDC)	Nominal operating current ±10% (mA)	Coil resistance ± 10%(Ω)	Parallel resistance (Ω)	Equivalent resistance (Ω)	Pick-up voltage (VDC)	Drop-out voltage (Min.)	Max. Allowable voltage (VDC)	Nominal operating power (W)
12	100	120	---	---	≤7.2	≥1.2	15.6	1.2
12	100	120	680	102	≤7.2	≥1.2	15.6	1.4
24	50	120	---	---	≤14.4	≥2.4	31.2	1.2
24	50	480	2700	407.5	≤14.4	≥2.4	31.2	1.4

Ordering Information

Nomenclature							
SARS	-S	-1	12	D	M	R	-XX
Special Parameter : Nil-Standard type, Letter or number-Special requirement							
Accessory Form : Nil-Without accessory, With resistor, D-With diode, DC-With diodes(see wiring diagram)							
Contact Form : Nil-Form C, M-Form A							
Coil Power : D-1.2W/1.4W							
Coil Voltage (VDC) : 12,24							
Number of Poles : 1-1 Pole							
Protective Construction : Nil-Dust cover S-Flux proofed SH-Sealed type washable							
Type Designation : SARS							

Outline Dimensions, Wiring Diagram (unit : mm)

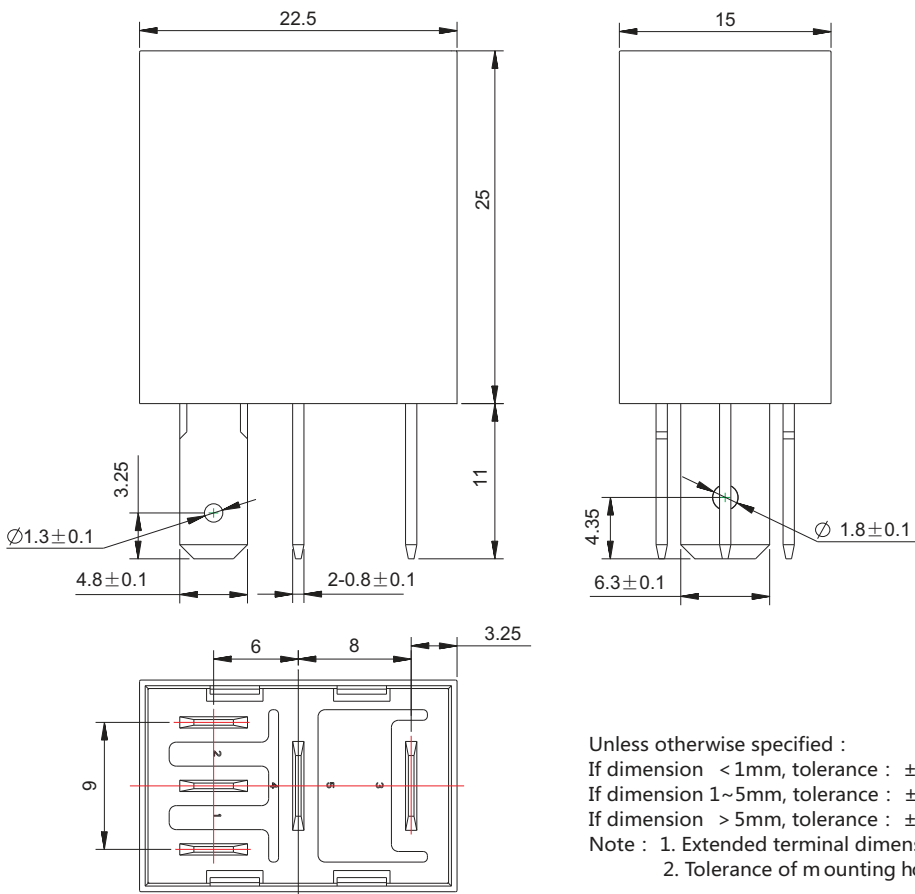

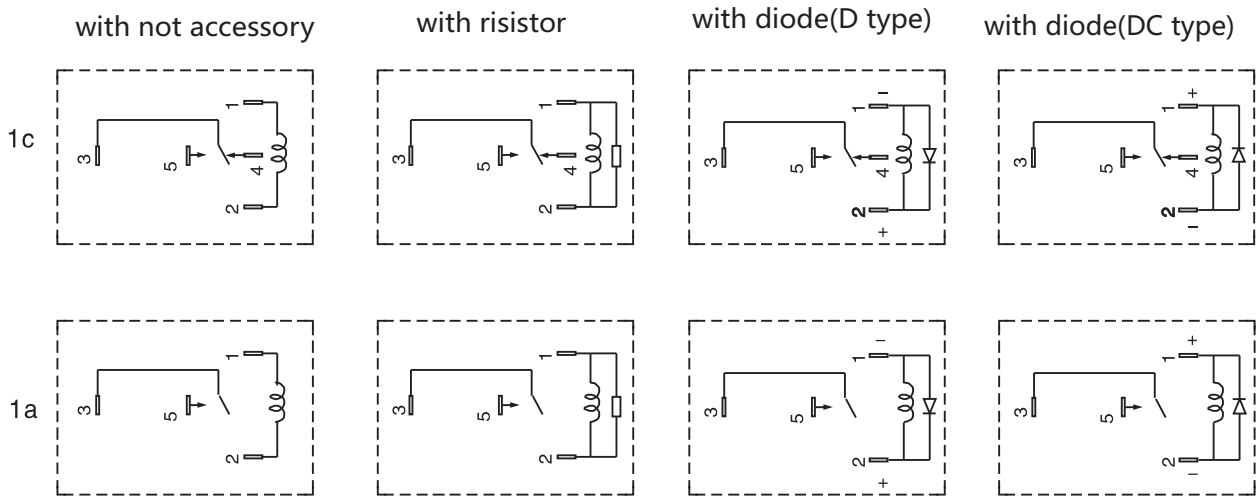

Wiring Diagram (bottom view)

Typical Applications

- Heater, fan control, fuel pump control, wiper control, headlight control.
- Car air conditioner, electromagnet control, lighting control, interlocks, office equipment, etc.

Characteristic Curves

1、Max. Allowable load range

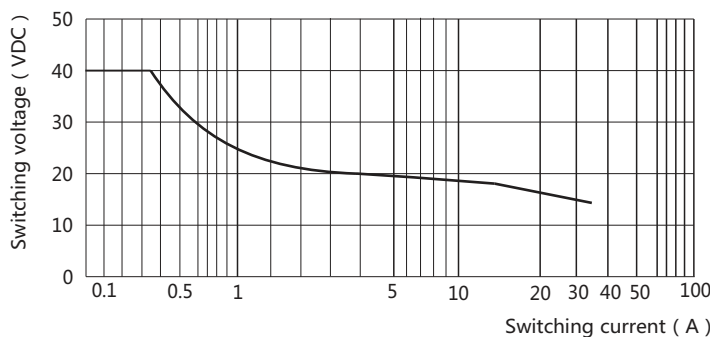

instruction : This figure is a case study of the NO open side

2.coil continuous voltage range

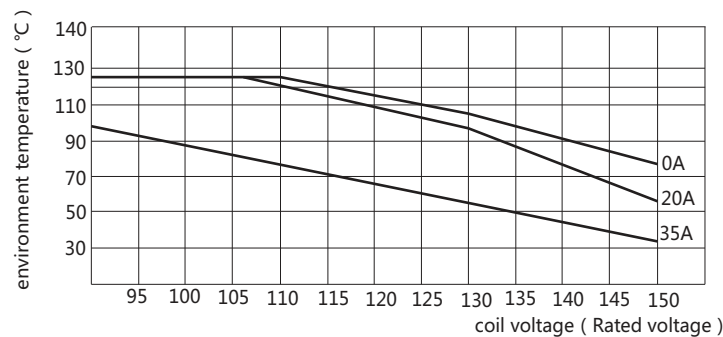

instruction : when the relay coil is applied to the maximum continuous operating voltage,the contact should not be loaded

Disclaimer:

This datasheet is the customers' reference. All the specification are subject to change without notice. We could not evaluate all the performance and all the parameters for every possible application. Thus the user should in a right position to choose the suitable product for their own application. If there is any query, please contact Sanyou for the technical service. However it is the user's responsibility to determine which product should be used only.