

used for:

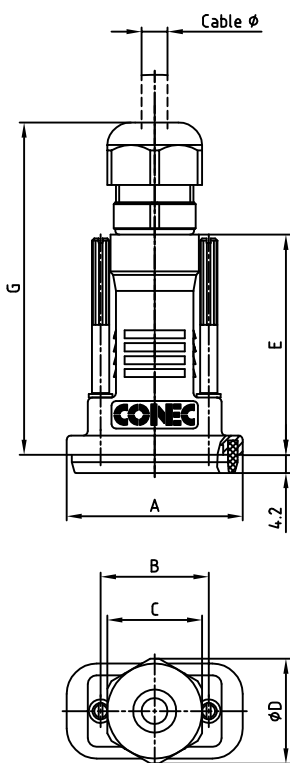

9pos.

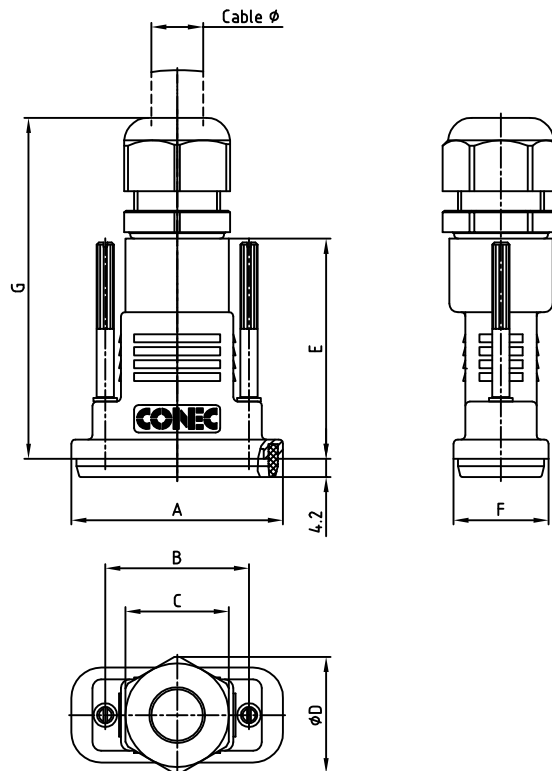

15pos.

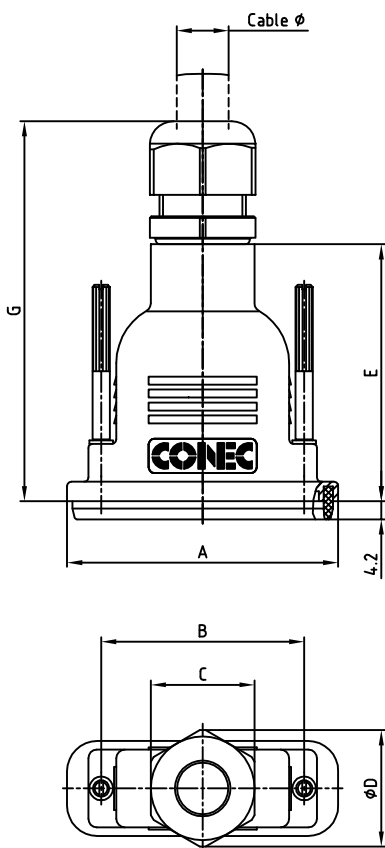

25-50pos.

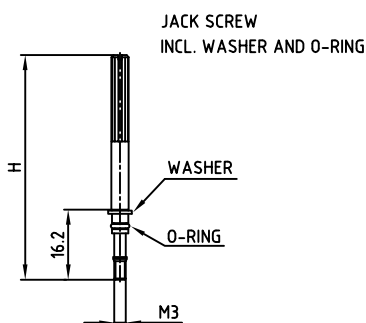

NOTES: (b)

1. HOOD: PBT GF UL 94 V0, BLACK
TEMPERATURE RANGE -30°C TO +90°C
2. FRONTSEALING: TPE UL 94 V0
TEMPERATURE RANGE -30°C TO +90°C
3. O-RING: NBR
TEMPERATURE RANGE -30°C TO +90°C
4. SCREWS: STAINLESS STEEL
5. RECOMMENDED TORQUE FOR JACK SCREW 30N cm

(b)

Shell-size	A	B	C	ØD	E	F	G ₋₁₋₃	H	Cable Ø	Part NO. Bulk package	Part NO. Single package
1	40.76	25.0	SW 22	24.6	51.0	22.0	77.0	44.0	5 - 10	165X15119X	165X15119XE
2	49.06	33.3	SW 24	26.5	51.0	22.0	79.0	52.0	6 - 12	165X15129X	165X15129XE
3	62.80	47.04	SW 24	26.5	59.5	22.0	87.5	52.0	6 - 12	165X15139X	165X15139XE
4	78.86	63.5	SW 33	36.2	67.0	22.0	99.0	52.0	9 - 16	165X15149X	165X15149XE
5	76.46	61.1	SW 42	47.0	67.0	24.8	107.0	52.0	13 - 20	165X15159X	165X15159XE

Directive 2002/95/EC RoHS compliant

THIS DRAWING MAY NOT BE COPIED OR REPRODUCED IN ANY WAY, AND MAY NOT BE PASSED ON TO A THIRD PARTY, WITHOUT WRITTEN PERMISSION. OWNERSHIP AND COPYRIGHT OF CONEC GmbH DO NOT ALTER CAD DRAWING BY HAND

tolerance		 dim. in mm	scale: 1:1	
			material: SEE NOTES	
2001	date	title:		
drawn	06.11.	WATER RESISTANT D-SUB HOOD		
appd.	06.11.	9-50 pos.		
norm		with M3 thread		
d-old		dwg no:		DIN-A
2 x b	Ä3842	20.12.10	K.H.	3
a	Origin			sh: 1/1
rev.	description	date	name	part no: SEE TABLE

