

PART NUMBER	ITEM ①		ITEM ②
	HANDLE	COLOR	
105-0301-001	NYLON	WHITE	BRASS
105-0302-001		RED	NICKEL PL .0001 MIN
105-0303-001		BLACK	
105-0304-001		GREEN	
105-0305-001			
105-0306-001		ORANGE	
105-0307-001		YELLOW	
105-0308-001		BROWN	
105-0309-001			
105-0310-001		BLUE	
105-0311-001			
105-0312-001		VIOLET	
105-0313-001		GRAY	
105-0314-001			
105-0315-001			
105-0316-001			
105-0317-001			
105-0318-001			
105-0319-001			
105-0320-001			

DRAWING NO.
B - 105-0301/0320-001

0	REVISIONS
---	-----------

REVISED AND REDRAWN. DRAWING WAS "C" SIZE 105-0301/0320-001/150 DATED 3-28-88. CREATED SHEET 2.

* REVISION NUMBER FOLLOWED BY AN ALPHA *
* CHARACTER INDICATES DRAWING CLARIFICATION OR PART NUMBER ADDITION ONLY. *

14b	1-7-03	R H	R J B			10-16-03	ECN 48699
-----	--------	--------	-------------	--	--	----------	-----------

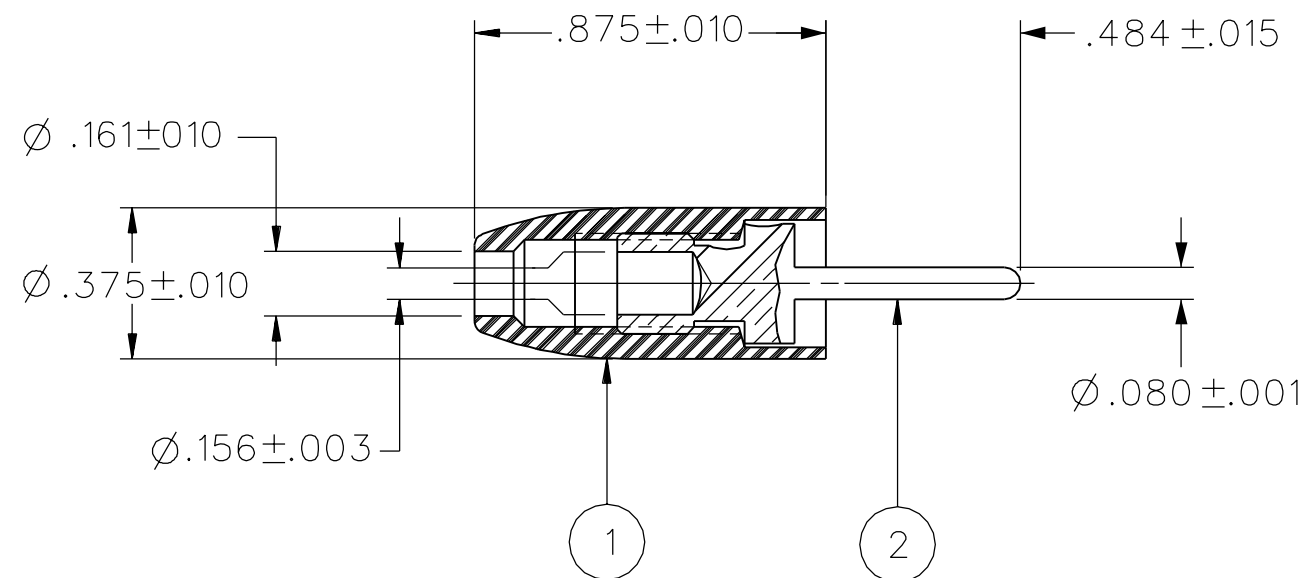

NOTES:

1. SPECIFICATIONS:

ELECTRICAL:

CURRENT RATING: 10 AMPS DC MINIMUM
 DIELECTRIC WITHSTANDING VOLTAGE: 3500 VRMS MIN AT SEA LEVEL
 RECOMMENDED WORKING VOLTAGE: 1750 VRMS MAX AT SEA LEVEL
 INSULATION RESISTANCE: 5000 MEGOHMS MIN
 CONTACT RESISTANCE: 10 MILLIOHMS MAXIMUM

MECHANICAL:

WIRE ACCEPTABILITY: 16 AWG OR SMALLER
 WIRE ATTACHMENT: SOLDER OR SOLDERLESS, SCREW DOWN HANDLE
 DURABILITY: 1000 CYCLES MINIMUM

ENVIRONMENTAL:

(MEETS OR EXCEEDS THE APPLICABLE PARAGRAPH OF MIL-PRF-39024)
 OPERATING TEMPERATURE: -55 DEG C TO 85 DEG C.
 TEMPERATURE RISE AT RATED CURRENT: 10 DEG C MAXIMUM
 CORROSION: MIL-STD-1344, METHOD 1001, CONDITION B
 SHOCK: MIL-STD-1344, METHOD 2004, CONDITION G
 VIBRATION: MIL-STD-1344, METHOD 2005, CONDITION I
 HUMIDITY: MIL-STD-1344, METHOD 1002, CONDITION B

CUSTOMER DRAWING

THIS DRAWING TO BE INTERPRETED PER ASME Y 14.5M - 1994

"μ STATION"

COMPANY CONFIDENTIAL

TOLERANCE UNLESS OTHERWISE SPECIFIED		DRAWN BY	DATE
DECIMALS	mm	RJB	12-16-02
.XX	_____	CHECKED BY	DATE
.XXX	_____		
MATL	_____	APPROVED BY	DATE
		RJB	10-16-03
FINISH	_____	RELEASE DATE	10-16-03
		U/M	INCH
		SCALE	4:1



Cinch Connectivity Solutions
 P.O. Box 1732
 Waseca, MN 56093
 1-800-247-8256

TITLE
 ASSEMBLY, .080 (2.0mm) TIP PLUG, INSULATED HANDLE, ROUND BODY, SOLDER OR SOLDERLESS BACKHOLE

SHEET
 2 OF 2

DRAWING NO.
 B - 105-0301/0320-001