

REVISIONS					
P	LTR	DESCRIPTION	DATE	DMN	APVD
M	REV PER ECO	16-018281	1-11-17	CT	DM

RAISED CAVITY IDENTIFICATION NUMBERS

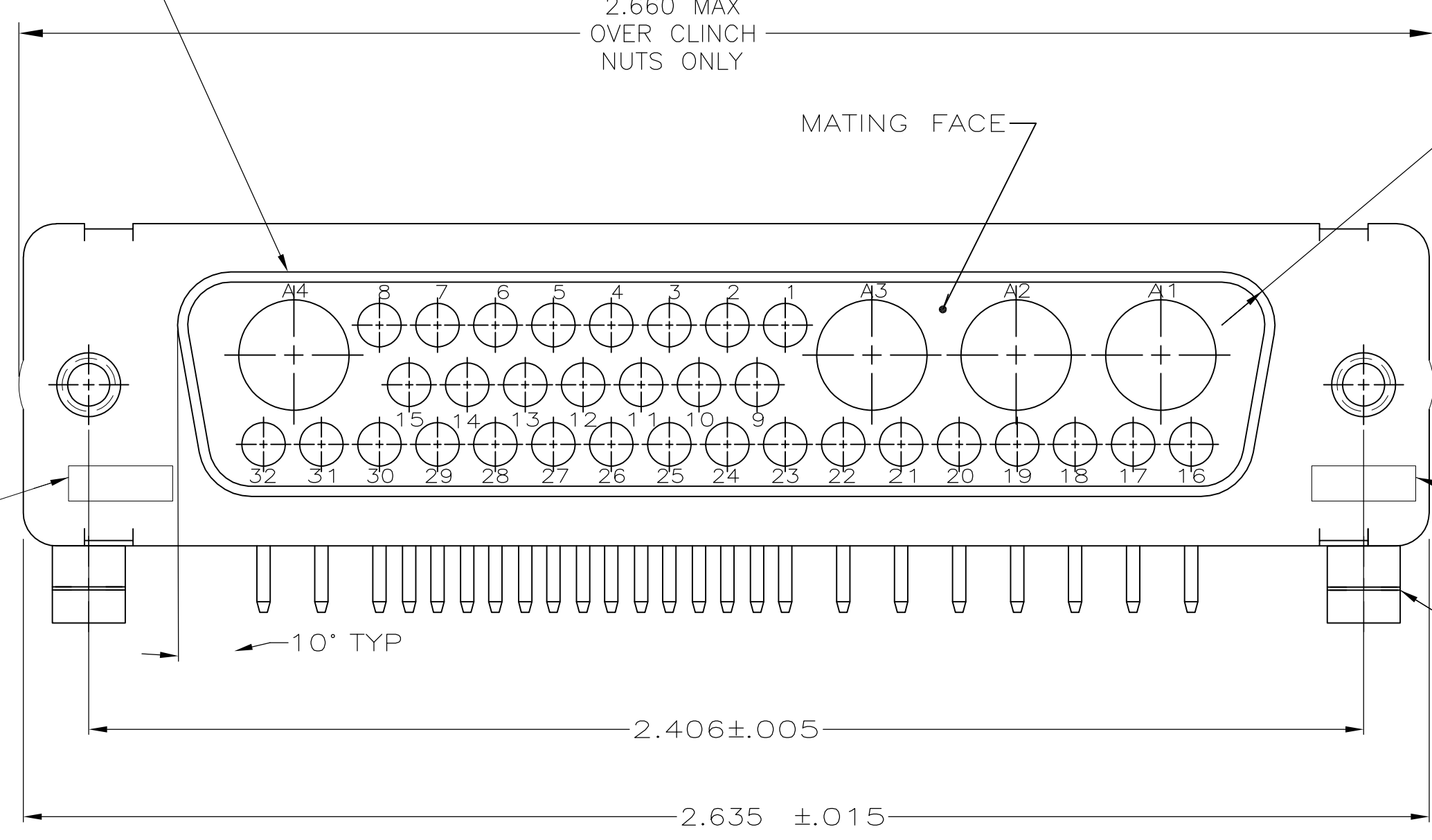

$\phi .045 \pm .002$   
 $\phi \varnothing 010$  (M) A (M) B (M)  
 32 PLC

$\phi .120 \pm .005$   
 $\phi \varnothing 010$  (M) A (M) B (M)  
 2 PLC

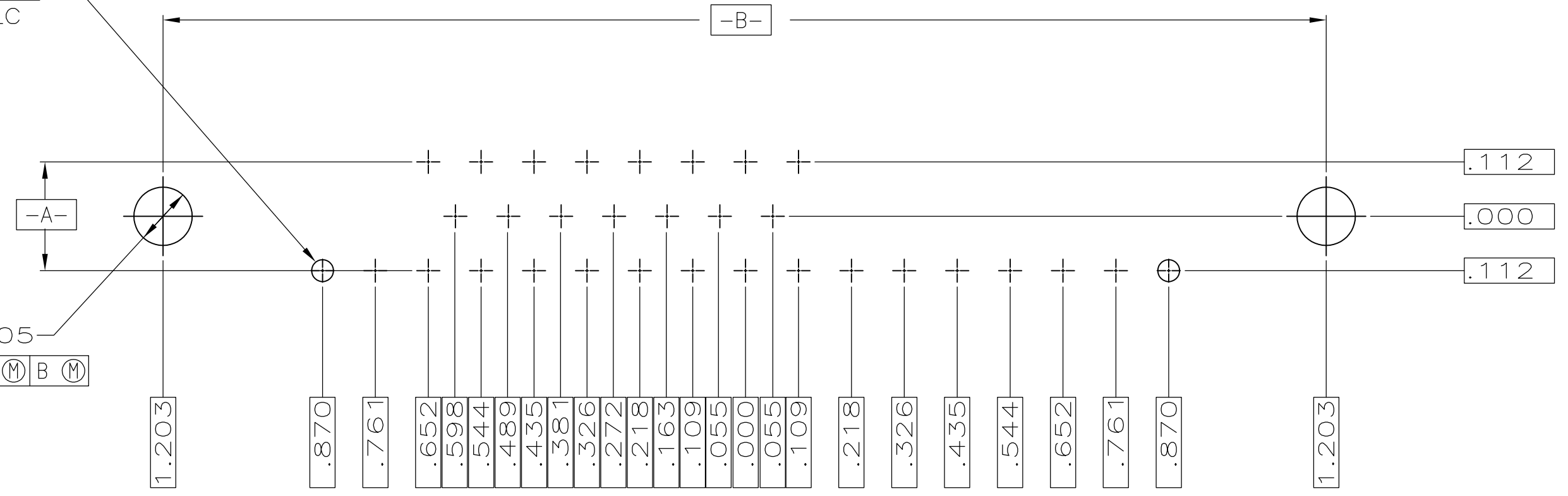

RECOMMENDED P.C. BOARD LAYOUT

BOARDLOCK (QTY = 2)  
 MAT'L: BRASS  
 FINISH: SEE TABLE  
 NO ORIENTATION OF BOARDLOCK REQD

AMP, AMP PART NO. & DATE  
 CODE MARKED ON FAR SIDE

FRONT & REAR SHELL  
 MAT'L: STEEL PER ASTM-A-109  
 FINISH: SEE TABLE

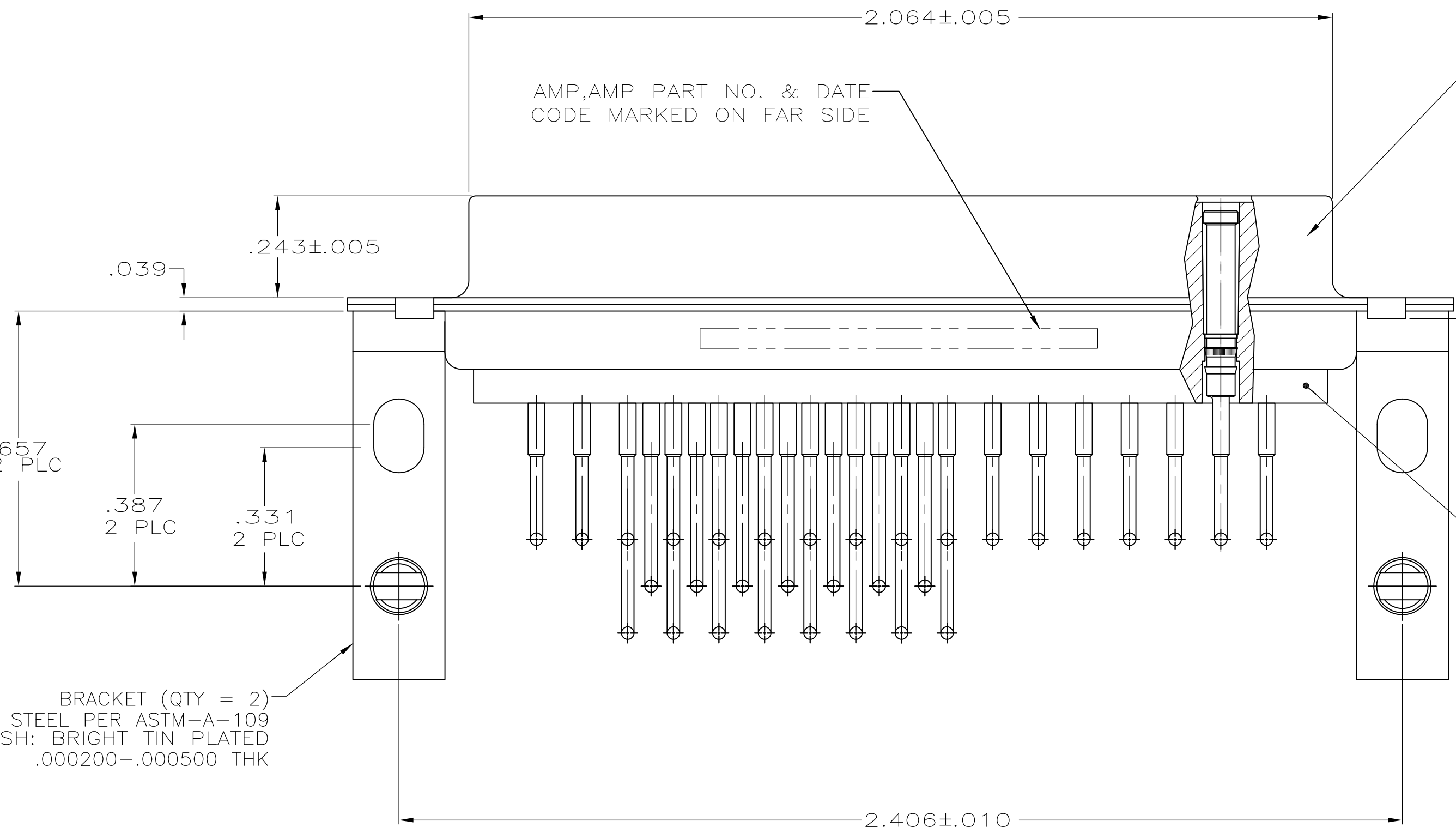

BRACKET (QTY = 2)  
 MAT'L: STEEL PER ASTM-A-109  
 FINISH: BRIGHT TIN PLATED  
 .000200-.000500 THK

INSERT  
 MAT'L: PPS, OR PPS PER ASTM  
 D4067, COLOR, BLACK

CLINCH NUT OR RIVNUT #4-40 UNC  
 MAT'L: STEEL  
 FINISH: SEE TABLE  
 QTY = 2

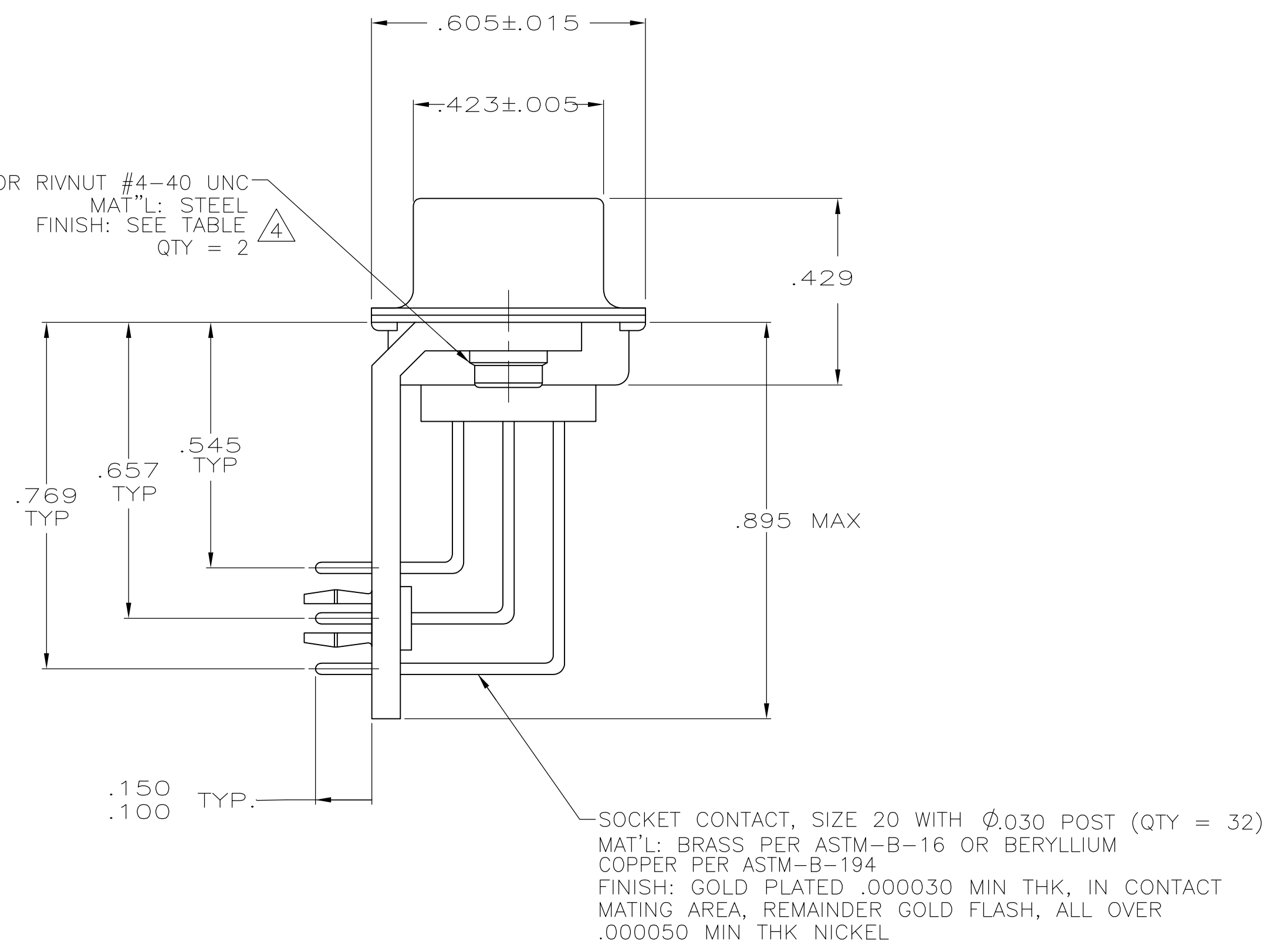

SOCKET CONTACT, SIZE 20 WITH  $\phi .030$  POST (QTY = 32)  
 MAT'L: BRASS PER ASTM-B-16 OR BERYLLIUM  
 COPPER PER ASTM-B-194  
 FINISH: GOLD PLATED .000030 MIN THK, IN CONTACT  
 MATING AREA, REMAINDER GOLD FLASH, ALL OVER  
 .000050 MIN THK NICKEL

RIVNUT, #4-40 UNC (QTY = 2)  
 MAT'L: STEEL  
 FINISH: YELLOW CHROMATE OVER CADMIUM

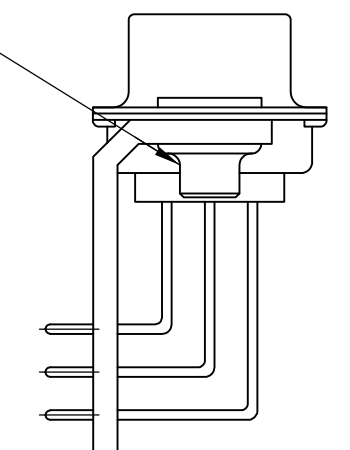

DETAIL A  
 ALTERNATE ASSEMBLY  
 SCALE 2:1

VIEW SHOWN  
 WITHOUT BOARDLOCK

- THIS RECEPTACLE WILL MATE WITH ANY 36C4 SIZE 5 PLUG IN THE AMPLIMITE SERIES.
  - THIS CONNECTOR ACCEPTS SIZE 8 POWER OR COAX SOCKET CONTACTS. (QTY = 4) NOT INCLUDED. CONSULT PRODUCT ENGINEERING FOR ADDITIONAL INFORMATION.
- UL/CSA DESIGNATION MARKED IN THIS LOCATION. (OPTIONAL)  
 RIVNUT MAY BE USED AS ALTERNATE. (SEE DETAIL A). (445029-1 ONLY)

MATTE TIN PLATED .000100 MIN THK	ZINC PLATED .000100 MIN THK WITH SUPPLEMENTARY CHROMATE	ZINC PLATED .000200 MIN THK WITH SUPPLEMENTARY CHROMATE	RoHS COMPLIANT	5-445029-1
MATTE TIN-LEAD .000100 MIN THK	ZINC PLATED .000100 MIN THK YELLOW CHROMATE	CADMIUM PLATED .000300-.000500 THK PER QQ-P-416, YELLOW CHROMATE	AS SHOWN	445029-1
BOARDLOCK FINISH	CLINCH NUT FINISH	SHELL FINISH	DESCRIPTION	PART NO.

THIS DRAWING IS A CONTROLLED DOCUMENT.

DIMENSIONS: INCHES	TOLERANCES UNLESS OTHERWISE SPECIFIED:	0 PLC ± .010	1 PLC ± .010	2 PLC ± .010	3 PLC ± .010	4 PLC ± .010	ANGLES ± 9° 30'
MATERIAL SEE CALLOUTS	FINISH SEE CALLOUTS	WEIGHT 0.000000	SIZE A1	CAGE CODE 00779	DRAWING NO. 445029	RESTRICTED TO	

CUSTOMER DRAWING SCALE 4:1 SHEET 1 OF 1 REV M

STE TE Connectivity

RECEPTACLE ASSY,AMPLIMITE,36C4,SIZE 5, SERIES 109,COAX-MIX,RT ANGLE,LOADED