

## Features

- High speed
  - $t_{AA} = 10 \text{ ns}$
- Low active power
  - $I_{CC} = 175 \text{ mA}$  at 10 ns
- Low CMOS standby power
  - $I_{SB2} = 25 \text{ mA}$
- Operating voltages of  $3.3 \pm 0.3\text{V}$
- 2.0V data retention
- Automatic power down when deselected
- TTL compatible inputs and outputs
- Easy memory expansion with  $\overline{CE}_1$ ,  $CE_2$ , and  $\overline{CE}_3$  features
- Available in Pb-free standard 119-ball PBGA

## Functional Description

The CY7C1024DV33 is a high performance CMOS static RAM organized as 128K words by 24 bits. This device has an automatic power down feature that significantly reduces power consumption when deselected.

To write to the device, enable the chip ( $\overline{CE}_1$  LOW,  $CE_2$  HIGH, and  $\overline{CE}_3$  LOW), while forcing the Write Enable (WE) input LOW.

To read from the device, enable the chip by taking  $\overline{CE}_1$  LOW,  $CE_2$  HIGH, and  $\overline{CE}_3$  LOW while forcing the Output Enable (OE) LOW and the Write Enable (WE) HIGH. See the [Truth Table](#) on page 7 for a complete description of Read and Write modes.

The 24 I/O pins ( $I/O_0$  to  $I/O_{23}$ ) are placed in a high impedance state when the device is deselected ( $\overline{CE}_1$  HIGH,  $CE_2$  LOW, or  $\overline{CE}_3$  HIGH) or when the output enable ( $\overline{OE}$ ) is HIGH during a write operation. ( $\overline{CE}_1$  LOW,  $CE_2$  HIGH,  $\overline{CE}_3$  LOW, and WE LOW).

## Logic Block Diagram

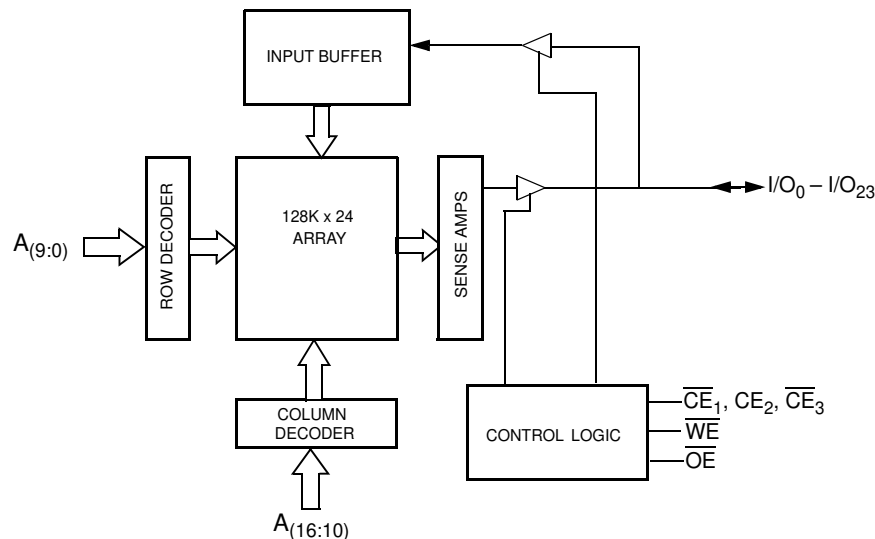

**Selection Guide**

Description	-10	Unit
Maximum Access Time	10	ns
Maximum Operating Current	175	mA
Maximum CMOS Standby Current	25	mA

**Pin Configuration**

Figure 1. 119-Ball PBGA Top View <sup>[1]</sup>

	1	2	3	4	5	6	7
<b>A</b>	NC	A	A	A	A	A	NC
<b>B</b>	NC	A	A	$\overline{CE}_1$	A	A	NC
<b>C</b>	I/O <sub>12</sub>	NC	CE <sub>2</sub>	NC	$\overline{CE}_3$	NC	I/O <sub>0</sub>
<b>D</b>	I/O <sub>13</sub>	V <sub>DD</sub>	V <sub>SS</sub>	V <sub>SS</sub>	V <sub>SS</sub>	V <sub>DD</sub>	I/O <sub>1</sub>
<b>E</b>	I/O <sub>14</sub>	V <sub>SS</sub>	V <sub>DD</sub>	V <sub>SS</sub>	V <sub>DD</sub>	V <sub>SS</sub>	I/O <sub>2</sub>
<b>F</b>	I/O <sub>15</sub>	V <sub>DD</sub>	V <sub>SS</sub>	V <sub>SS</sub>	V <sub>SS</sub>	V <sub>DD</sub>	I/O <sub>3</sub>
<b>G</b>	I/O <sub>16</sub>	V <sub>SS</sub>	V <sub>DD</sub>	V <sub>SS</sub>	V <sub>DD</sub>	V <sub>SS</sub>	I/O <sub>4</sub>
<b>H</b>	I/O <sub>17</sub>	V <sub>DD</sub>	V <sub>SS</sub>	V <sub>SS</sub>	V <sub>SS</sub>	V <sub>DD</sub>	I/O <sub>5</sub>
<b>J</b>	NC	V <sub>SS</sub>	V <sub>DD</sub>	V <sub>SS</sub>	V <sub>DD</sub>	V <sub>SS</sub>	NC
<b>K</b>	I/O <sub>18</sub>	V <sub>DD</sub>	V <sub>SS</sub>	V <sub>SS</sub>	V <sub>SS</sub>	V <sub>DD</sub>	I/O <sub>6</sub>
<b>L</b>	I/O <sub>19</sub>	V <sub>SS</sub>	V <sub>DD</sub>	V <sub>SS</sub>	V <sub>DD</sub>	V <sub>SS</sub>	I/O <sub>7</sub>
<b>M</b>	I/O <sub>20</sub>	V <sub>DD</sub>	V <sub>SS</sub>	V <sub>SS</sub>	V <sub>SS</sub>	V <sub>DD</sub>	I/O <sub>8</sub>
<b>N</b>	I/O <sub>21</sub>	V <sub>SS</sub>	V <sub>DD</sub>	V <sub>SS</sub>	V <sub>DD</sub>	V <sub>SS</sub>	I/O <sub>9</sub>
<b>P</b>	I/O <sub>22</sub>	V <sub>DD</sub>	V <sub>SS</sub>	V <sub>SS</sub>	V <sub>SS</sub>	V <sub>DD</sub>	I/O <sub>10</sub>
<b>R</b>	I/O <sub>23</sub>	NC	NC	NC	NC	NC	I/O <sub>11</sub>
<b>T</b>	NC	A	A	$\overline{WE}$	A	A	NC
<b>U</b>	NC	A	A	$\overline{OE}$	A	A	NC

**Note**

1. NC pins are not connected on the die.

## Maximum Ratings

Exceeding maximum ratings may impair the useful life of the device. These user guidelines are not tested.

Storage Temperature ..... -65°C to +150°C

Ambient Temperature with Power Applied ..... -55°C to +125°C

Supply Voltage on  $V_{CC}$  Relative to GND <sup>[2]</sup> ..... -0.5V to +4.6V

DC Voltage Applied to Outputs in High Z State <sup>[2]</sup> ..... -0.5V to  $V_{CC} + 0.5V$

DC Input Voltage <sup>[2]</sup> ..... -0.5V to  $V_{CC} + 0.5V$

Current into Outputs (LOW) ..... 20 mA

Static Discharge Voltage..... >2001V (MIL-STD-883, Method 3015)

Latch Up Current ..... >200 mA

## Operating Range

Range	Ambient Temperature	$V_{CC}$
Industrial	-40°C to +85°C	3.3V ± 0.3V

## DC Electrical Characteristics

Over the Operating Range

Parameter	Description	Test Conditions <sup>[3]</sup>	-10		Unit
			Min	Max	
$V_{OH}$	Output HIGH Voltage	$V_{CC} = \text{Min}, I_{OH} = -4.0 \text{ mA}$	2.4		V
$V_{OL}$	Output LOW Voltage	$V_{CC} = \text{Min}, I_{OL} = 8.0 \text{ mA}$		0.4	V
$V_{IH}$	Input HIGH Voltage		2.0	$V_{CC} + 0.3$	V
$V_{IL}$ <sup>[2]</sup>	Input LOW Voltage		-0.3	0.8	V
$I_{IX}$	Input Leakage Current	$GND \leq V_I \leq V_{CC}$	-1	+1	μA
$I_{OZ}$	Output Leakage Current	$GND \leq V_{OUT} \leq V_{CC}$ , output disabled	-1	+1	μA
$I_{CC}$	$V_{CC}$ Operating Supply Current	$V_{CC} = \text{Max}, f = f_{MAX} = 1/t_{RC}$ $I_{OUT} = 0 \text{ mA CMOS levels}$		175	mA
$I_{SB1}$	Automatic CE Power Down Current — TTL Inputs	Max $V_{CC}$ , $\overline{CE} \geq V_{IH}$ $V_{IN} \geq V_{IH}$ or $V_{IN} \leq V_{IL}$ , $f = f_{MAX}$		30	mA
$I_{SB2}$	Automatic CE Power Down Current — CMOS Inputs	Max $V_{CC}$ , $\overline{CE} \geq V_{CC} - 0.3V$ , $V_{IN} \geq V_{CC} - 0.3V$ , or $V_{IN} \leq 0.3V$ , $f = 0$		25	mA

## Capacitance

Tested initially and after any design or process changes that may affect these parameters.

Parameter	Description	Test Conditions	Max	Unit
$C_{IN}$	Input Capacitance	$T_A = 25^\circ\text{C}, f = 1 \text{ MHz}, V_{CC} = 3.3V$	8	pF
$C_{OUT}$	I/O Capacitance		10	pF

## Thermal Resistance

Tested initially and after any design or process changes that may affect these parameters.

Parameter	Description	Test Conditions	119-Ball PBGA	Unit
$\theta_{JA}$	Thermal Resistance (Junction to Ambient)	Still air, soldered on a 3 × 4.5 inch, four layer printed circuit board	20.31	°C/W
$\theta_{JC}$	Thermal Resistance (Junction to Case)		8.35	°C/W

### Notes

2.  $V_{IL}(\text{min}) = -2.0V$  and  $V_{IH}(\text{max}) = V_{CC} + 2V$  for pulse durations of less than 20 ns.

3.  $\overline{CE}$  refers to a combination of  $\overline{CE}_1$ ,  $\overline{CE}_2$ , and  $\overline{CE}_3$ .  $\overline{CE}$  is LOW when  $\overline{CE}_1$ ,  $\overline{CE}_3$  are LOW and  $\overline{CE}_2$  is HIGH.  $\overline{CE}$  is HIGH when  $\overline{CE}_1$  is HIGH, or  $\overline{CE}_2$  is LOW, or  $\overline{CE}_3$  is HIGH.

Figure 2. AC Test Loads and Waveform<sup>[4]</sup>

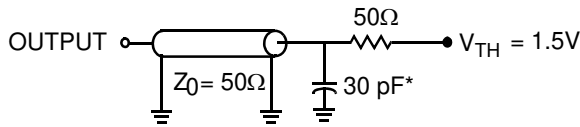

(a)

\*Capacitive Load consists of all components of the test environment

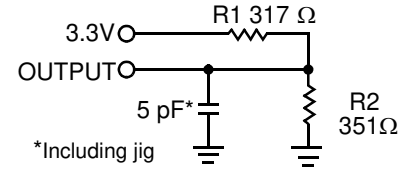

(b)

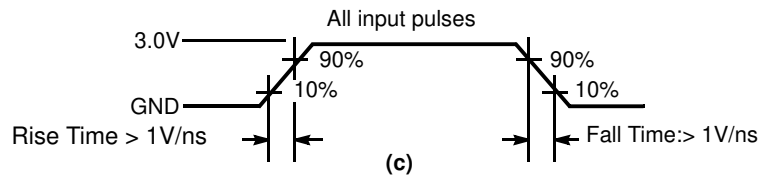

(c)

## AC Switching Characteristics

Over the Operating Range<sup>[5]</sup>

Parameter	Description	-10		Unit
		Min	Max	
<b>Read Cycle</b>				
$t_{power}^{[6]}$	$V_{CC}$ (Typical) to the First Access	100		$\mu s$
$t_{RC}$	Read Cycle Time	10		ns
$t_{AA}$	Address to Data Valid		10	ns
$t_{OHA}$	Data Hold from Address Change	3		ns
$t_{ACE}$	$\overline{CE}$ Active LOW to Data Valid <sup>[3]</sup>		10	ns
$t_{DOE}$	$\overline{OE}$ LOW to Data Valid		5	ns
$t_{LZOE}$	$\overline{OE}$ LOW to Low Z <sup>[7]</sup>	1		ns
$t_{HZOE}$	$\overline{OE}$ HIGH to High Z <sup>[7]</sup>		5	ns
$t_{LZCE}$	$\overline{CE}$ Active LOW to Low Z <sup>[3, 7]</sup>	3		ns
$t_{HZCE}$	$\overline{CE}$ Deselect HIGH to High Z <sup>[3, 7]</sup>		5	ns
$t_{PU}$	$\overline{CE}$ Active LOW to Power Up <sup>[3, 8]</sup>	0		ns
$t_{PD}$	$\overline{CE}$ Deselect HIGH to Power Down <sup>[3, 8]</sup>		10	ns

### Notes

- Valid SRAM operation does not occur until the power supplies have reached the minimum operating  $V_{DD}$  (3.0V). 100  $\mu s$  ( $t_{power}$ ) after reaching the minimum operating  $V_{DD}$ , normal SRAM operation can begin including reduction in  $V_{DD}$  to the data retention ( $V_{CCDR}$ : 2.0V) voltage.
- Test conditions assume signal transition time of 3 ns or less, timing reference levels of 1.5V, and input pulse levels of 0 to 3.0V. Test conditions for the read cycle use output loading as shown in part a) of Figure 2, unless specified otherwise.
- $t_{POWER}$  gives the minimum amount of time that the power supply is at typical  $V_{CC}$  values until the first memory access is performed.
- $t_{HZOE}$ ,  $t_{HZCE}$ ,  $t_{HZWE}$ ,  $t_{LZOE}$ ,  $t_{LZCE}$ , and  $t_{LZWE}$  are specified with a load capacitance of 5 pF as in part (b) of Figure 2. Transition is measured  $\pm 200$  mV from steady state voltage.
- These parameters are guaranteed by design and are not tested.

**AC Switching Characteristics** (continued)

Over the Operating Range <sup>[5]</sup>

Parameter	Description	-10		Unit
		Min	Max	
<b>Write Cycle</b> <sup>[9, 10]</sup>				
t <sub>WC</sub>	Write Cycle Time	10		ns
t <sub>SCE</sub>	$\overline{CE}$ active LOW to Write End <sup>[3]</sup>	7		ns
t <sub>AW</sub>	Address Setup to Write End	7		ns
t <sub>HA</sub>	Address Hold from Write End	0		ns
t <sub>SA</sub>	Address Setup to Write Start	0		ns
t <sub>PWE</sub>	$\overline{WE}$ Pulse Width	7		ns
t <sub>SD</sub>	Data Setup to Write End	5.5		ns
t <sub>HD</sub>	Data Hold from Write End	0		ns
t <sub>LZWE</sub>	$\overline{WE}$ HIGH to Low Z <sup>[7]</sup>	3		ns
t <sub>HZWE</sub>	$\overline{WE}$ LOW to High Z <sup>[7]</sup>		5	ns

**Data Retention Characteristics**

Over the Operating Range

Parameter	Description	Conditions <sup>[3]</sup>	Min	Typ	Max	Unit
V <sub>DR</sub>	V <sub>CC</sub> for Data Retention		2			V
I <sub>CCDR</sub>	Data Retention Current	V <sub>CC</sub> = 2V, $\overline{CE} \geq V_{CC} - 0.2V$ , V <sub>IN</sub> ≥ V <sub>CC</sub> - 0.2V or V <sub>IN</sub> ≤ 0.2V			25	mA
t <sub>CDR</sub> <sup>[11]</sup>	Chip Deselect to Data Retention Time		0			ns
t <sub>R</sub> <sup>[12]</sup>	Operation Recovery Time		t <sub>RC</sub>			ns

**Data Retention Waveform**

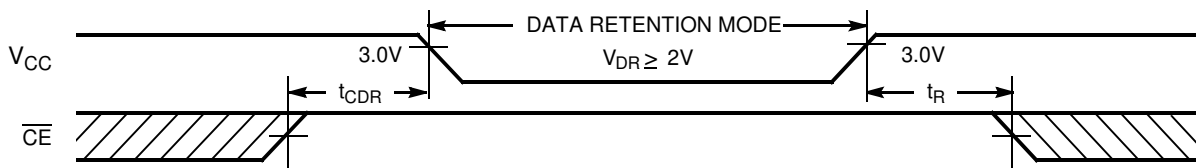

**Notes**

9. The internal write time of the memory is defined by the overlap of  $\overline{CE}_1$  and  $\overline{CE}_2$  and  $\overline{CE}_3$  LOW and  $\overline{WE}$  LOW. Chip enables must be active and  $\overline{WE}$  must be LOW to initiate a write. The transition of any of these signals terminate the write. The input data setup and hold timing is referenced to the leading edge of the signal that terminates the write.
10. The minimum write cycle time for Write Cycle No. 3 ( $\overline{WE}$  controlled,  $\overline{OE}$  LOW) is the sum of t<sub>HZWE</sub> and t<sub>SD</sub>.
11. Tested initially and after any design or process changes that may affect these parameters.
12. Full device operation requires linear V<sub>CC</sub> ramp from V<sub>DR</sub> to V<sub>CC(min)</sub> ≥ 50 μs or stable at V<sub>CC(min)</sub> ≥ 50 μs.

Switching Waveforms

Figure 3. Read Cycle No. 1 (Address Transition Controlled) [13, 14]

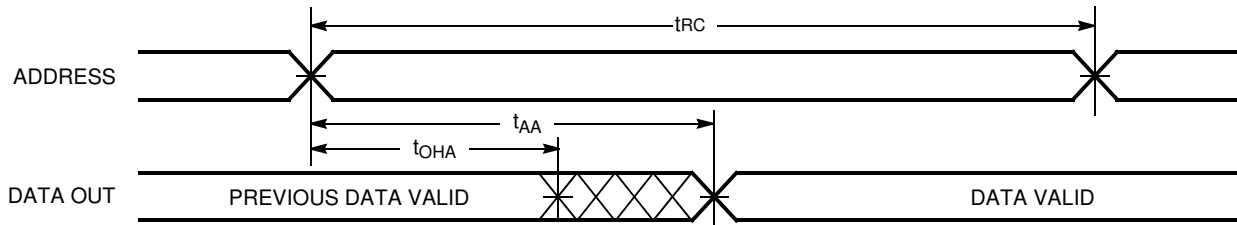

Figure 4. Read Cycle No. 2 ( $\overline{OE}$  Controlled) [3, 14, 15]

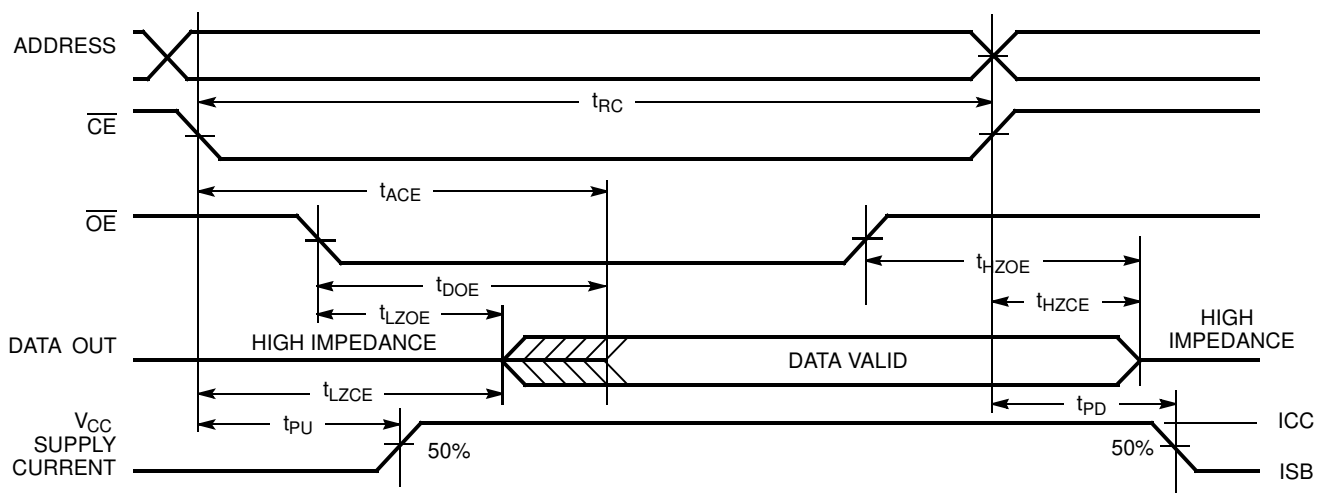
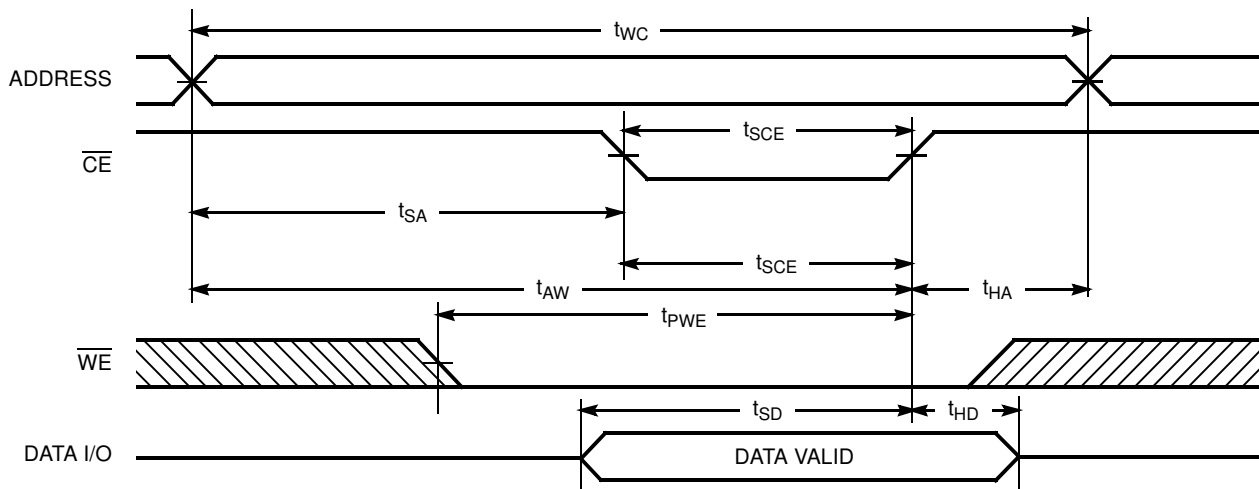

Figure 5. Write Cycle No. 1 ( $\overline{CE}$  Controlled) [3, 16, 17]



Notes

- 13. Device is continuously selected.  $\overline{OE}$ ,  $\overline{CE} = V_{IL}$ .
- 14.  $\overline{WE}$  is HIGH for read cycle.
- 15. Address valid before or similar to  $\overline{CE}$  transition LOW.
- 16. Data I/O is high impedance if  $\overline{OE} = V_{IH}$ .
- 17. If  $\overline{CE}$  goes HIGH simultaneously with  $\overline{WE}$  going HIGH, the output remains in a high impedance state.

Switching Waveforms (continued)

Figure 6. Write Cycle No. 2 ( $\overline{WE}$  Controlled,  $\overline{OE}$  HIGH During Write) [3, 16, 17]

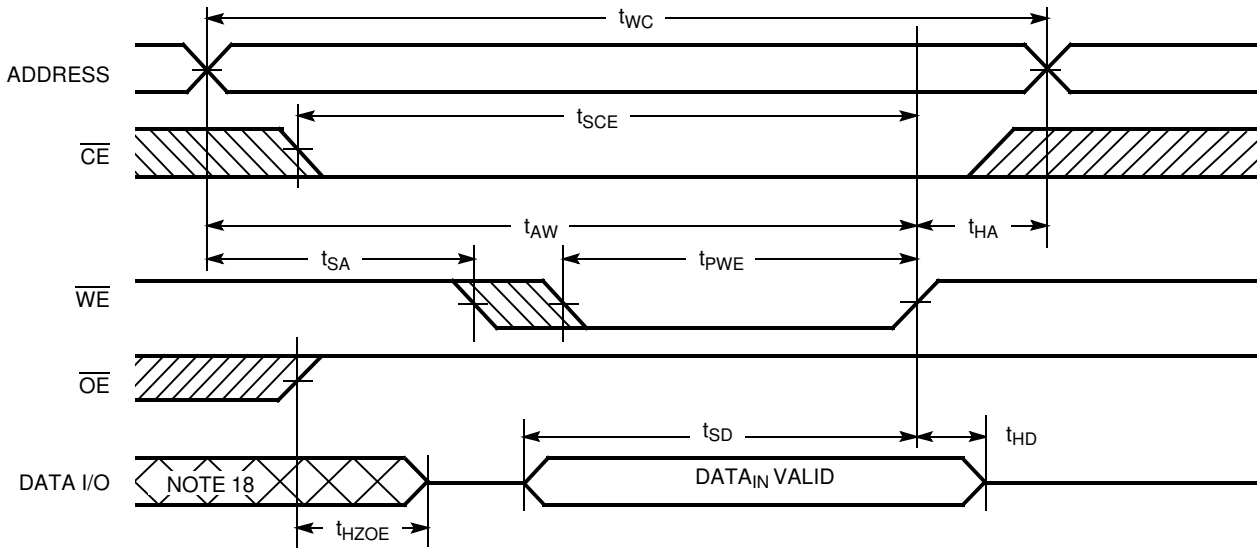
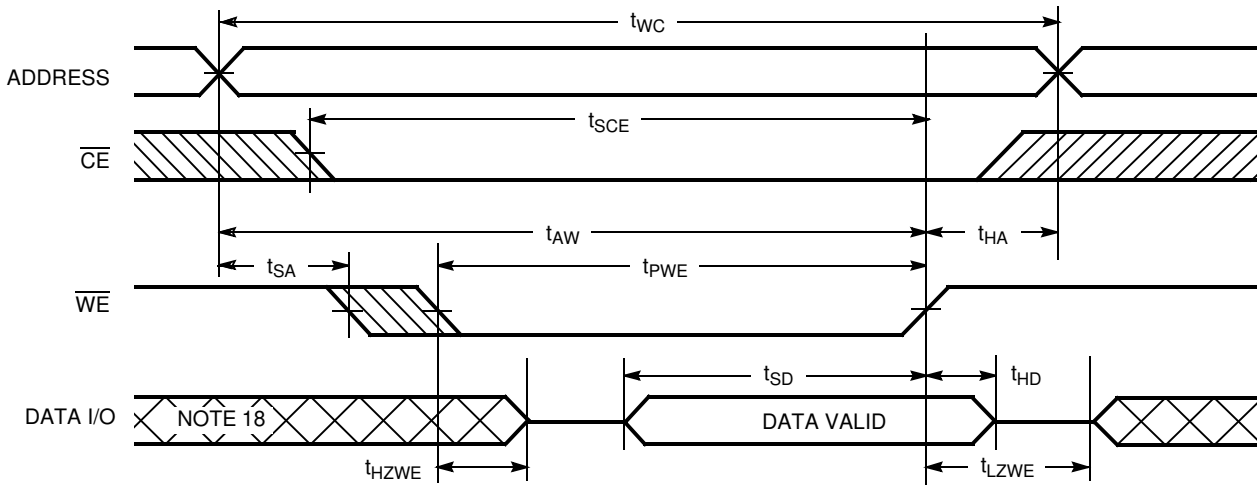

Figure 7. Write Cycle No. 3 ( $\overline{WE}$  Controlled,  $\overline{OE}$  LOW) [3, 17]



Truth Table

$\overline{CE}_1$	$\overline{CE}_2$	$\overline{CE}_3$	$\overline{OE}$	$\overline{WE}$	I/O <sub>0</sub> – I/O <sub>23</sub>	Mode	Power
H	X	X	X	X	High Z	Power Down	Standby (I <sub>SB</sub> )
X	L	X	X	X	High Z	Power Down	Standby (I <sub>SB</sub> )
X	X	H	X	X	High Z	Power Down	Standby (I <sub>SB</sub> )
L	H	L	L	H	Full Data Out	Read	Active (I <sub>CC</sub> )
L	H	L	X	L	Full Data In	Write	Active (I <sub>CC</sub> )
L	H	L	H	H	High Z	Selected, Outputs Disabled	Active (I <sub>CC</sub> )

Note  
18. During this period, the I/Os are in the output state and input signals are not applied.

Ordering Information

Speed (ns)	Ordering Code	Package Name	Package Type	Operating Range
10	CY7C1024DV33-10BGXI	51-85115	119-Ball Plastic Ball Grid Array (14 x 22 x 2.4 mm) (Pb-Free)	Industrial

Package Diagram

Figure 8. 119-Ball PBGA (14 x 22 x 2.4 mm)

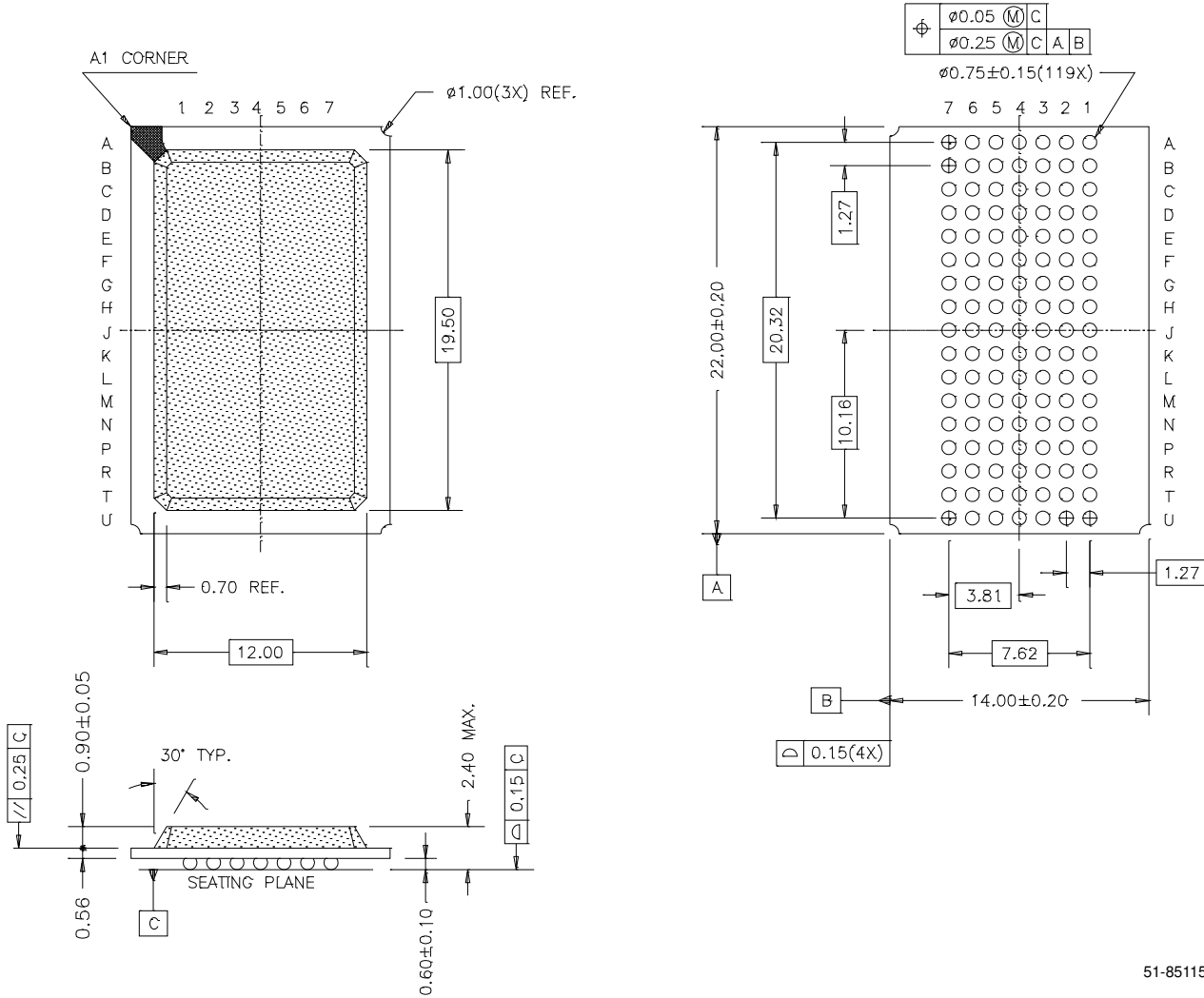

51-85115-B



## Document History Page

Document Title: CY7C1024DV33, 3-Mbit (128K X 24) Static RAM				
Document Number: 001-08353				
Rev.	ECN No.	Orig. of Change	Submission Date	Description of Change
**	469517	NXR	See ECN	New data sheet
*A	499604	NXR	See ECN	Added note 1 for NC pins Changed I <sub>CC</sub> specification from 150 mA to 185 mA Updated Test Condition for I <sub>CC</sub> in DC Electrical Characteristics table Added note for t <sub>ACE</sub> , t <sub>LZCE</sub> , t <sub>HZCE</sub> , t <sub>PU</sub> , t <sub>PD</sub> , t <sub>SCE</sub> in AC Switching Characteristics Table on page 4
*B	1462586	VKN/SFV	See ECN	Converted from preliminary to final Updated block diagram Changed I <sub>CC</sub> specification from 185 mA to 225 mA Updated thermal specs
*C	2604677	VKN/PYRS	11/12/08	Removed Commercial operating range, Added Industrial operating range Removed 8 ns speed bin, Added 10 ns speed bin

## Sales, Solutions, and Legal Information

### Worldwide Sales and Design Support

Cypress maintains a worldwide network of offices, solution centers, manufacturer’s representatives, and distributors. To find the office closest to you, visit us at [cypress.com/sales](http://cypress.com/sales).

### Products

PSoC	<a href="http://psoc.cypress.com">psoc.cypress.com</a>
Clocks & Buffers	<a href="http://clocks.cypress.com">clocks.cypress.com</a>
Wireless	<a href="http://wireless.cypress.com">wireless.cypress.com</a>
Memories	<a href="http://memory.cypress.com">memory.cypress.com</a>
Image Sensors	<a href="http://image.cypress.com">image.cypress.com</a>

### PSoC Solutions

General	<a href="http://psoc.cypress.com/solutions">psoc.cypress.com/solutions</a>
Low Power/Low Voltage	<a href="http://psoc.cypress.com/low-power">psoc.cypress.com/low-power</a>
Precision Analog	<a href="http://psoc.cypress.com/precision-analog">psoc.cypress.com/precision-analog</a>
LCD Drive	<a href="http://psoc.cypress.com/lcd-drive">psoc.cypress.com/lcd-drive</a>
CAN 2.0b	<a href="http://psoc.cypress.com/can">psoc.cypress.com/can</a>
USB	<a href="http://psoc.cypress.com/usb">psoc.cypress.com/usb</a>

© Cypress Semiconductor Corporation, 2006-2008. The information contained herein is subject to change without notice. Cypress Semiconductor Corporation assumes no responsibility for the use of any circuitry other than circuitry embodied in a Cypress product. Nor does it convey or imply any license under patent or other rights. Cypress products are not warranted nor intended to be used for medical, life support, life saving, critical control or safety applications, unless pursuant to an express written agreement with Cypress. Furthermore, Cypress does not authorize its products for use as critical components in life-support systems where a malfunction or failure may reasonably be expected to result in significant injury to the user. The inclusion of Cypress products in life-support systems application implies that the manufacturer assumes all risk of such use and in doing so indemnifies Cypress against all charges.

Any Source Code (software and/or firmware) is owned by Cypress Semiconductor Corporation (Cypress) and is protected by and subject to worldwide patent protection (United States and foreign), United States copyright laws and international treaty provisions. Cypress hereby grants to licensee a personal, non-exclusive, non-transferable license to copy, use, modify, create derivative works of, and compile the Cypress Source Code and derivative works for the sole purpose of creating custom software and/or firmware in support of licensee product to be used only in conjunction with a Cypress integrated circuit as specified in the applicable agreement. Any reproduction, modification, translation, compilation, or representation of this Source Code except as specified above is prohibited without the express written permission of Cypress.

Disclaimer: CYPRESS MAKES NO WARRANTY OF ANY KIND, EXPRESS OR IMPLIED, WITH REGARD TO THIS MATERIAL, INCLUDING, BUT NOT LIMITED TO, THE IMPLIED WARRANTIES OF MERCHANTABILITY AND FITNESS FOR A PARTICULAR PURPOSE. Cypress reserves the right to make changes without further notice to the materials described herein. Cypress does not assume any liability arising out of the application or use of any product or circuit described herein. Cypress does not authorize its products for use as critical components in life-support systems where a malfunction or failure may reasonably be expected to result in significant injury to the user. The inclusion of Cypress’ product in a life-support systems application implies that the manufacturer assumes all risk of such use and in doing so indemnifies Cypress against all charges.

Use may be limited by and subject to the applicable Cypress software license agreement.