

SABLE-X AND SABLE-X-R2 DEVELOPMENT BOARD USER GUIDE



Last updated
April 6, 2018

The information in this document is subject to change without notice.

Table of Contents

1	Introduction	3
1.1	<i>Purpose & Scope</i>	3
1.2	<i>Applicable Documents</i>	3
1.3	<i>Revision History</i>	3
2	SaBLE-x and SaBLE-x-R2 Development Board Description	4
3	SaBLE-x and SaBLE-x-R2 Development Board Hardware	7
3.1	<i>Antennas and RF Connector</i>	7
3.2	<i>Interface Connectors.....</i>	8
3.3	<i>Development Board Power</i>	12
3.4	<i>Bus Isolation DIP Switches</i>	13
3.5	<i>User Input Push Button Switches</i>	14
3.6	<i>Sensors</i>	14
3.7	<i>External Memory</i>	15
3.8	<i>LED Indicators.....</i>	16
4	SaBLE-x Development Board Schematics	17
5	Adapter Boards.....	18
6	Evaluation and Development	27
6.1	<i>Overview</i>	27
6.2	<i>Evaluation/Development Options.....</i>	27
6.3	<i>Programming and Debugging</i>	29
7	Contacting LSR.....	33

The information in this document is subject to change without notice.

1 Introduction

1.1 Purpose & Scope

The purpose of this document is to provide details regarding the setup and use of the SaBLE-x or SaBLE-x-R2 module on a Development Board. This document covers a description of the Development Board, its features, and a brief tutorial on how to operate the module Development Board.

1.2 Applicable Documents

- SaBLE-x Datasheet (330-0166)
- SaBLE-x-R2 Datasheet (330-0237)
- SaBLE-x and SaBLE-x-R2 Application Guide (330-0167)

1.3 Revision History

Date	ECN	Change Description	Revision
5/19/2015	105-2015	Initial release	1.0
10/5/15	192-2015	Added bootloader config information and FTDI VCP driver link	1.1
12/2/2015	221-2015	Fixed XDS110 debugger info	1.2
12/4/2015	225-2015	Replaced reference to SmartRF05 board to SmartRF06 in Section 5.1.4	1.3
2/5/2016	20-2016	Updated to Laird Color Scheme	1.4
6/16/2017	102-2017	Added the SaBLE-x-R2 dev board to be covered by this document	2.0
7/27/2017	132-2017	Added more info in section 6.2 Evaluation/Development Options	2.1
4/6/2018	27-2018	Fix VCC switch state in table 17	2.2

Table 1 Revision History

2 SaBLE-x and SaBLE-x-R2 Development Board Description

The SaBLE-x and SaBLE-x-R2 Development Boards are an evaluation and development platform for the SaBLE-x and SaBLE-x-R2 Bluetooth Smart Modules. The Development Boards provide all the necessary connectors, jumpers, indicators, and switches to test and debug all aspects of the SaBLE-x or SaBLE-x-R2 modules. The connectors and switches on the Development Board make it a convenient platform for product development, as it allows a means to disconnect the on-board peripherals and IO, and provides an easy means to connect your own IO.

The Development Board also has flexible power options that support a coin cell battery, external power supply, or USB power.

The Development Board can be used to evaluate basic BLE connectivity. Additionally, it is possible to put the SaBLE-x or SaBLE-x-R2 module into static RF test modes so that RF performance can be evaluated.

The Development Board contains an FTDI USB to TTL UART IC. When the dev board is plugged into a PC it will show up in the device manager as a virtual COM port. If the PC is missing the driver, it can be downloaded from FTDI: <http://www.ftdichip.com/Drivers/VCP.htm>

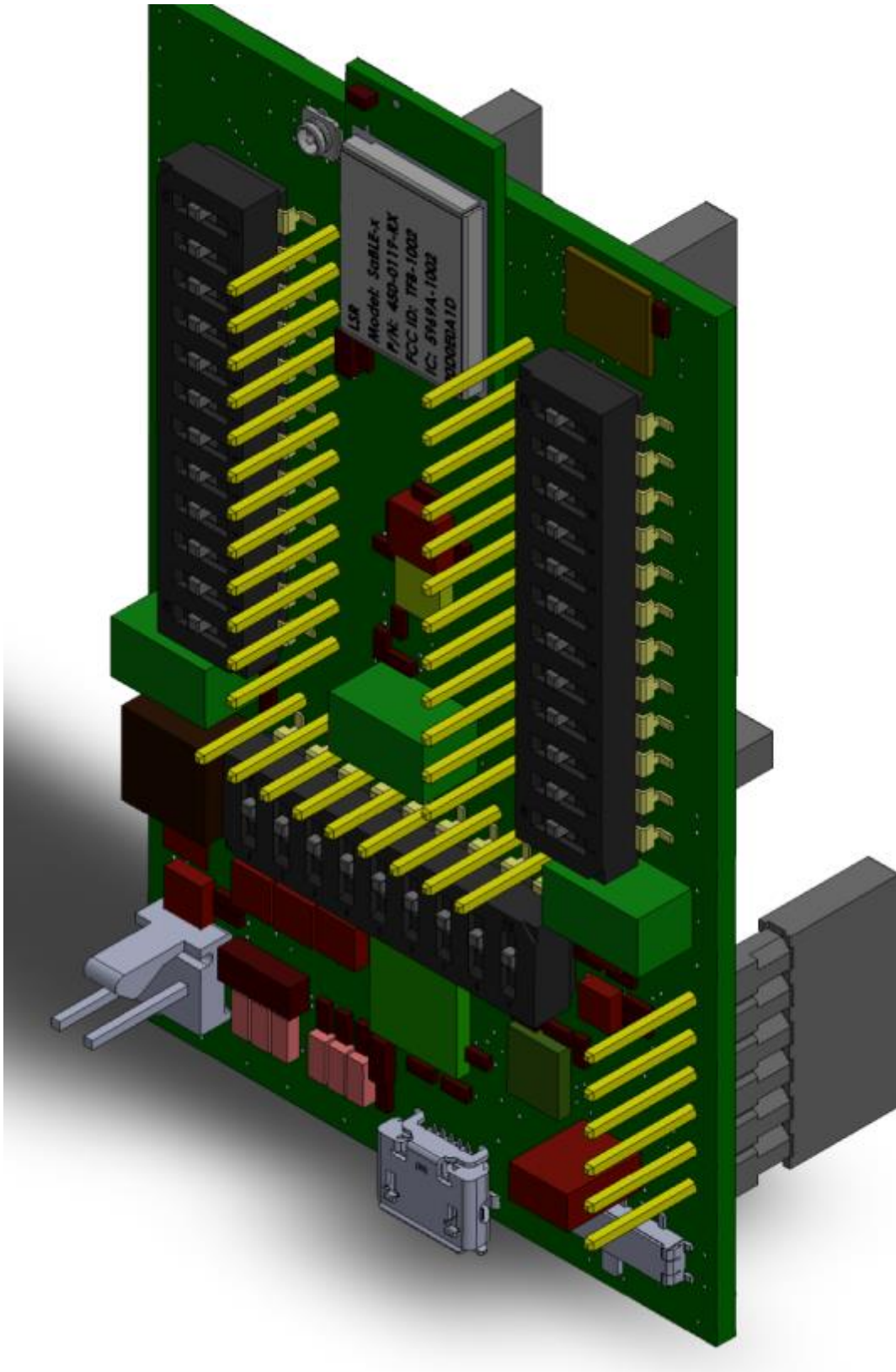

Figure 1 Development Board Viewed from Top

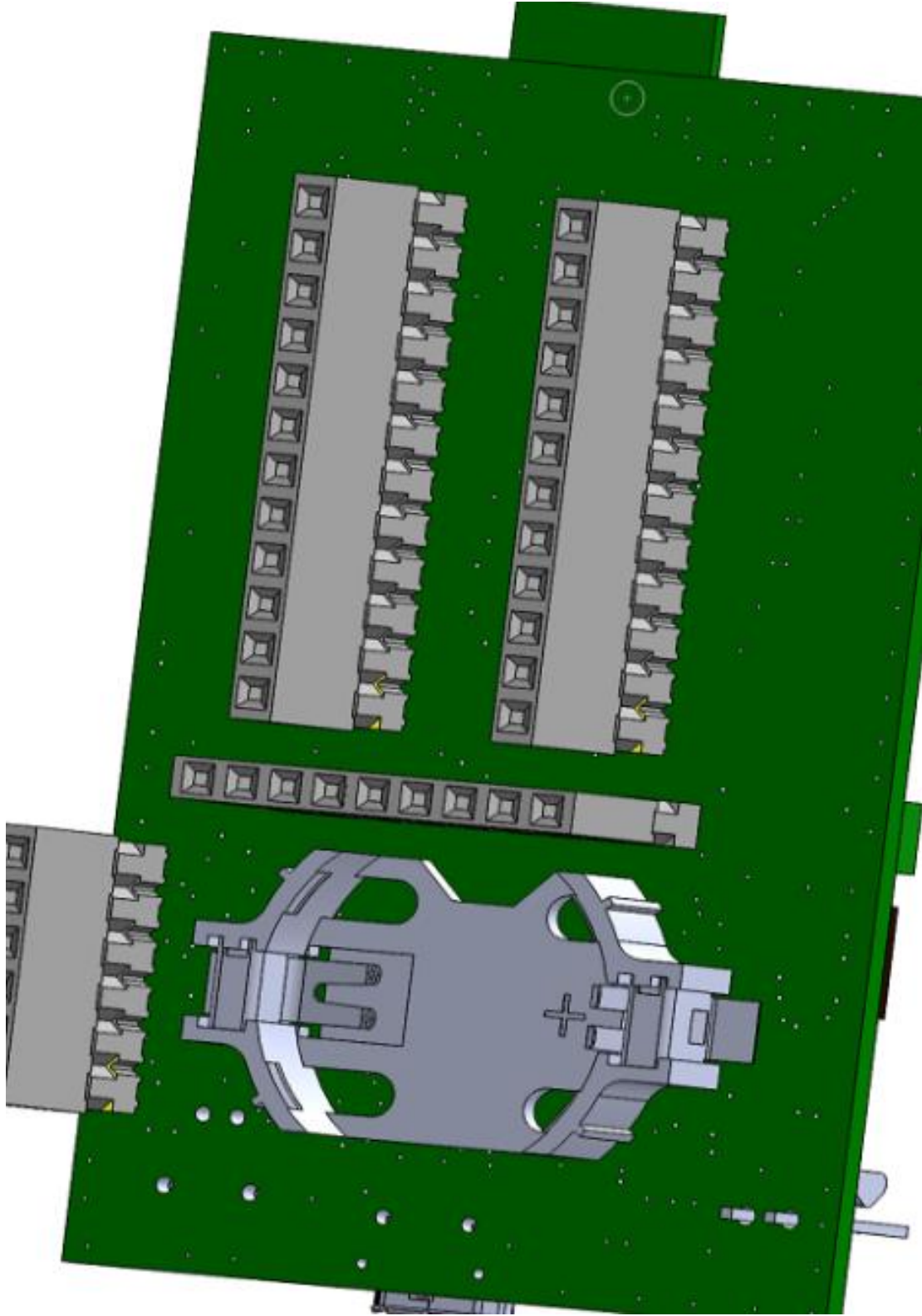

Figure 2 Development Board Viewed From Bottom

3 SaBLE-x and SaBLE-x-R2 Development Board Hardware

Please refer to the Reference Design Schematic, the Reference Design PCB, and the Reference Design BOM in the SaBLE-x and SaBLE-x-R2 Module Application Guide for more details on the SaBLE-x or SaBLE-x-R2 reference design PCB. Note that the Reference Design PCB files are available for download on the LSR website.

3.1 Antennas and RF Connector

There are two SaBLE-x module versions and two SaBLE-x-R2 module versions:

LSR Part Number	Description
450-0119	SaBLE-x Module, PCB Trace Antenna
450-0144	SaBLE-x Module, External Antenna Port (Onboard Antenna Disabled)
450-0177	SaBLE-x-R2 Module, PCB Trace Antenna
450-0178	SaBLE-x-R2 Module, External Antenna Port (Onboard Antenna Disabled)

Table 2 Module Part Numbers

The SaBLE-x or SaBLE-x-R2 Development Board include an on board U.FL RF connector J3 (**Figure 3**). When used in conjunction with a SaBLE-x or SaBLE-x-R2 module with External Antenna Port, J3 provides a RF connection point to external antennas or test equipment. When the Development Board is used with used with a SaBLE-x or SaBLE-x-R2 module with PCB Trace Antenna, the U.FL connector has no electrical connection to the module.

The SaBLE-x and SaBLE-x-R2 modules are EMC certified for FCC, IC, ETSI, Japan, and Australia/New Zealand. See the SaBLE-x or SaBLE-x-R2 datasheet and application guide for further information regarding EMC certifications.

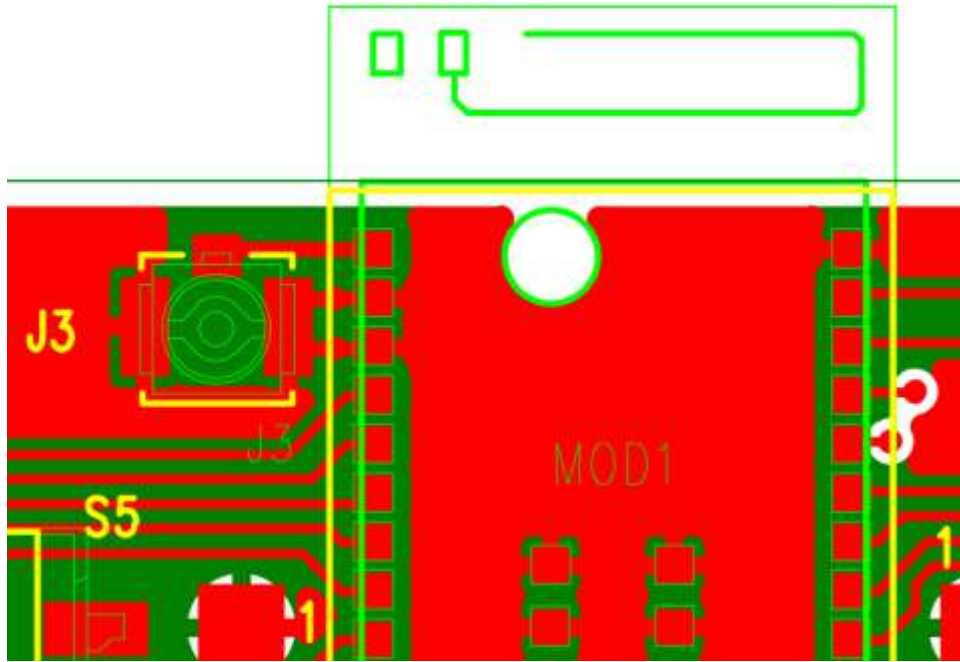

Figure 3 RF Connector J3

3.2 Interface Connectors

The development board has 4 connectors, J1, J2, J4, and J5 for interfacing to LSR Adapter Boards, as well as various prototyping platforms. The connectors provide access to all of the I/O on the SaBLE-x or SaBLE-x-R2 module with a dual purpose .1" (2.54mm) connector that allows for mating to either male pins or female sockets. Refer to **Table 3**, **Table 4**, **Table 5**, and **Table 6** for details on the signals brought out to these connectors.

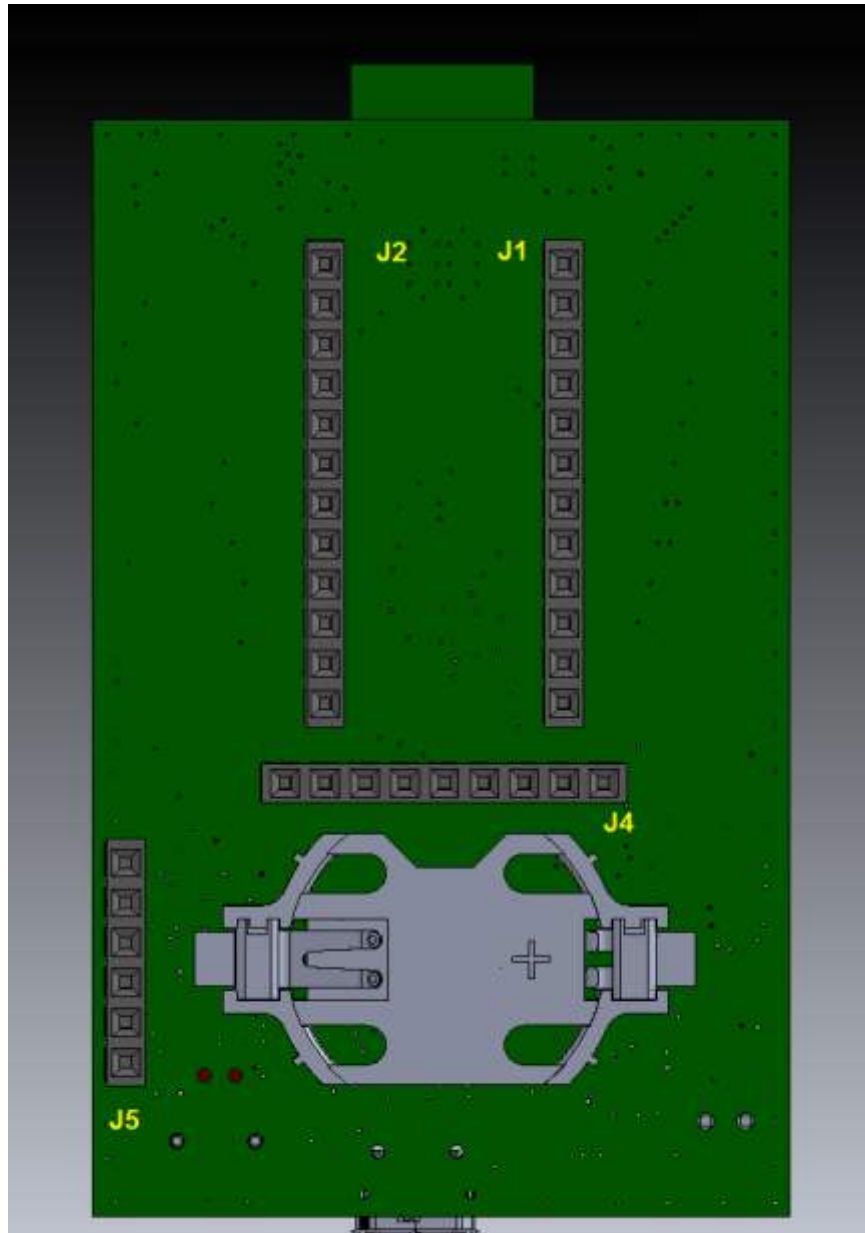

Figure 4 Dev Board Connectors

J1 Pin Number	Pin Name	Module Pin Type	Description
1	GND	Ground	Ground
2	GND	Ground	Ground
3	GND	Ground	Ground
4	NC	NC	Not Connected
5	NC	NC	Not Connected
6	/RESET	DI	Module Reset (Active Low)
7	JTAG_TCKC	Digital I/O	JTAG_TCKC
8	JTAG_TMSC	Digital I/O	JTAG_TMSC
9	NC	NC	Not Connected
10	NC	NC	Not Connected
11	VCC	Power	Power Supply Input (1.8v to 3.8v)
12	VCC	Power	Power Supply Input (1.8v to 3.8v)

Table 3 Connector J1 Pinout

J2 Pin Number	Pin Name	Module Pin Type	Description
1	GND	Ground	Ground
2	DIO 14	DIO	GPIO, Analog Input, ULP Sensor Interface
3	DIO 13	DIO	GPIO, Analog Input, ULP Sensor Interface
4	DIO 12	DIO	GPIO, Analog Input, ULP Sensor Interface
5	DIO 11	DIO	GPIO, Analog Input, ULP Sensor Interface
6	NC	NC	Not Connected
7	NC	NC	Not Connected
8	NC	NC	Not Connected
9	NC	NC	Not Connected
10	DIO 9	DIO	GPIO, Analog Input, ULP Sensor Interface
11	DIO 10	DIO	GPIO, Analog Input, ULP Sensor Interface
12	GND	Ground	Ground

Table 4 Connector J2 Pinout

The information in this document is subject to change without notice.

J4 Pin Number	Pin Name	Module Pin Type	Description
1	DIO 5 JTAG_TDO	DIO	GPIO, JTAG_TDO, ULP Sensor Interface, LED Driving Capability
2	DIO 6 JTAG_TDI	DIO	GPIO, JTAG_TDO, ULP Sensor Interface, LED Driving Capability
3	DIO 4	DIO	GPIO, LED Driving Capability
4	DIO 3	DIO	GPIO, LED Driving Capability
5	DIO 2	DIO	GPIO, ULP Sensor Interface, LED Driving Capability
6	DIO 1 / BOOT RX	DIO	GPIO, ULP Sensor Interface, Bootloader RX (UART0)
7	DIO 0 / BOOT TX	DIO	GPIO, ULP Sensor Interface, Bootloader TX (UART0)
8	DIO 7	DIO	GPIO, ULP Sensor Interface
9	DIO 8	DIO	GPIO, ULP Sensor Interface

Table 5 Connector J4 Pinout

J5 Pin Number	Pin Name	Module Pin Type	Description
1	EXT 3V3	Power	External Power Supply to Module
2	EXT DIO 0 / BOOT TX	DIO	GPIO, ULP Sensor Interface, Bootloader TX (UART0) External, Switched
3	EXT DIO 1 / BOOT RX	DIO	GPIO, ULP Sensor Interface, Bootloader RX (UART0) External, Switched
4	EXT /RESET	DIO	Module Reset (Active Low), External, Switched
5	EXT DIO 9 / BOOT EN	DIO	Boot Enable, External, Switched
6	GND	Ground	Ground

Table 6 Connector J5 Pinout

3.3 Development Board Power

The Development Board provides 4 possible sources for powering the SaBLE-x or SaBLE-x-R2 module and development board peripherals.

3.3.1 Power Connectors

- B1 - 3V Lithium Coin Cell Battery
- J6 - External Power Supply (2.3v to 3.6v)
- J9 - 5V USB Power (Regulated by U5 to 3.3V)
- J5 - Power directly to the SaBLE-x/SaBLE-x-R2 module PIN1 and PIN6 (2.3v to 3.6v)

NOTE: On the first batch of SaBLE-x Development Boards the silk screen does not align correctly with the actual slide switch positions. As such start with the switch at one end and count the detents as you slide it to insure it is in the intended position. This issue does not affect SaBLE-x-R2 Development Boards.

3.3.2 Power Selection

Switch S4 is a 4 position slide switch that acts as on/off switch to the Development Board and the SaBLE-x or SaBLE-x-R2 module. It also provides a means of selecting the source of powering the Development Board. Jumper J4, located next to S4, provide a means of isolating power going to the module for the purpose of measuring module current (**Figure 5**).

NOTE: When using the SaBLE-x TI Adapter Board in conjunction with the Development Board, power is supplied from the TI evaluation platform, and switch S4 must be in the OFF position.

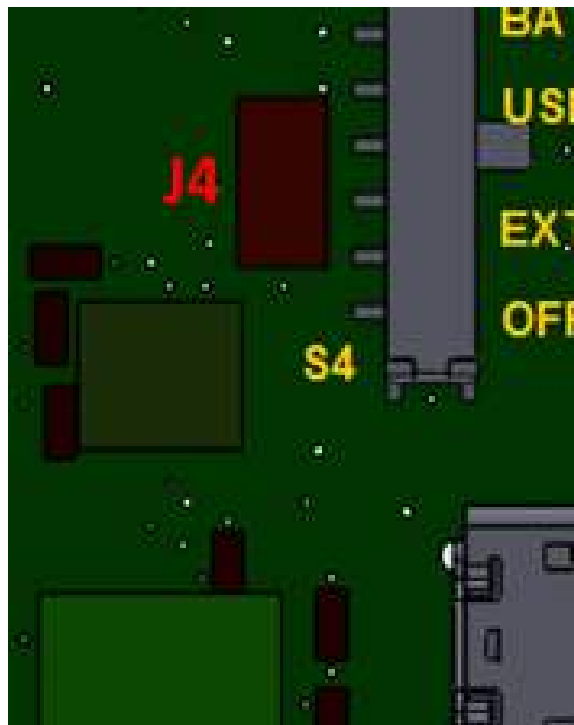

Figure 5 Power Switch S4

3.4 Bus Isolation DIP Switches

DIP switch SW 5, 6, and 7 provide a means of individually isolating the SaBLE-x or SaBLE-x-R2 module pins from the various hardware of the development board. When in the off (open) position, the corresponding pin of the SaBLE-x or SaBLE-x-R2 module is isolated to the corresponding interface connector.

In addition to the bus isolation switches, U3 adds additional protection against Bus contention UART and enable line when an external is sensed on J5.

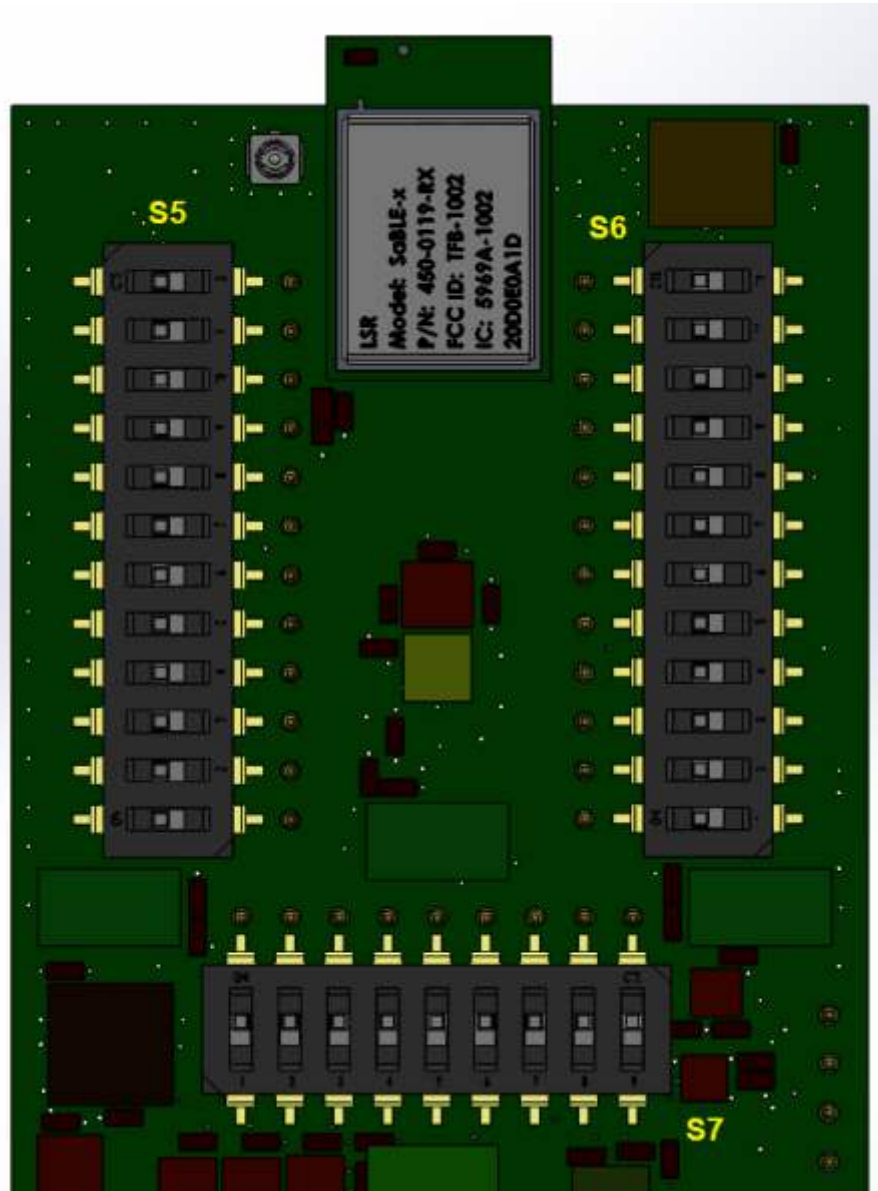

Figure 6 Bus Isolation Switches

3.5 User Input Push Button Switches

There are 3 push button switches on the Development board which allow user input to the module.

- S1 - User Defined Switch
- S2 - Module Reset
- S3 - Bootload Enable (enables bootloader function on the SaBLE-x or SaBLE-x-R2 module)

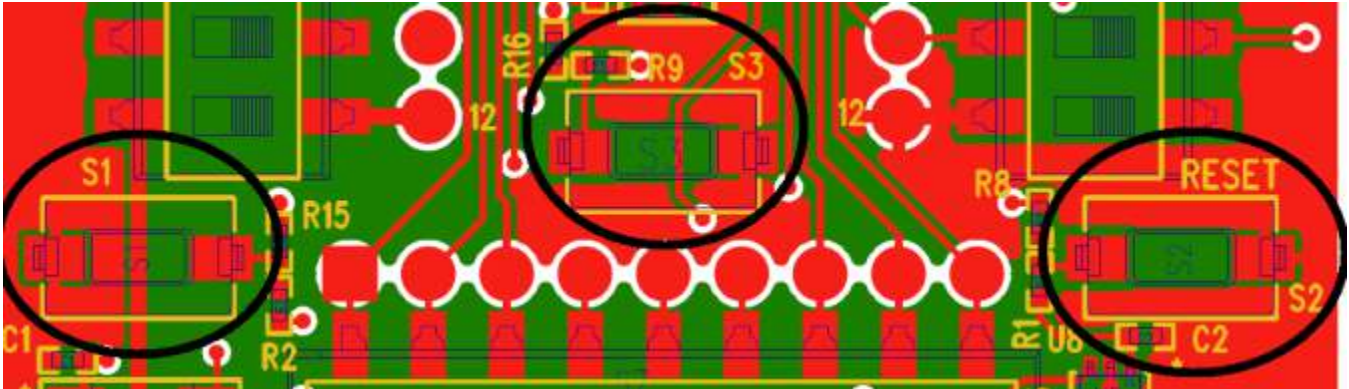

Figure 7 Push Button Switches

3.6 Sensors

The Development Board includes 3 sensors connected to the SaBLE-x or SaBLE-x-R2 module on a common I2C interface.

- U1 - Temperature Sensor (provides Development Board temperature)
- U7 - Tri-Axis Accelerometer (provides tilt, roll, and yaw attitude of the Development Board)
- U9 - Ambient Light Sensor (provides Development Board ambient light intensity)

3.6.1 I2C Interface To Sensors

The Development Board includes an I2C interface. The I2C provides an interface between the SaBLE-x or SaBLE-x-R2 module and the on board temperature sensor (U1), accelerometer (U7) and ambient light sensor (U9), as well as other I2C compatible devices connected by the two-wire I2C serial bus. External components attached to the I2C bus communicate serial data to and from the module through the two-wire I2C interface. The I2C bus supports any slave or master I2C compatible device.

Figure 8 shows an example of an I2C bus. Each I2C device is recognized by a unique address and can operate as either a transmitter or a receiver. A device connected to the I2C bus is either a master or a slave when performing data transfers. A master initiates a data transfer and generates the clock signal (SCL). Any device addressed by a master is considered a slave. I2C data is communicated using the serial data (SDA) pin and the serial clock (SCL) pin.

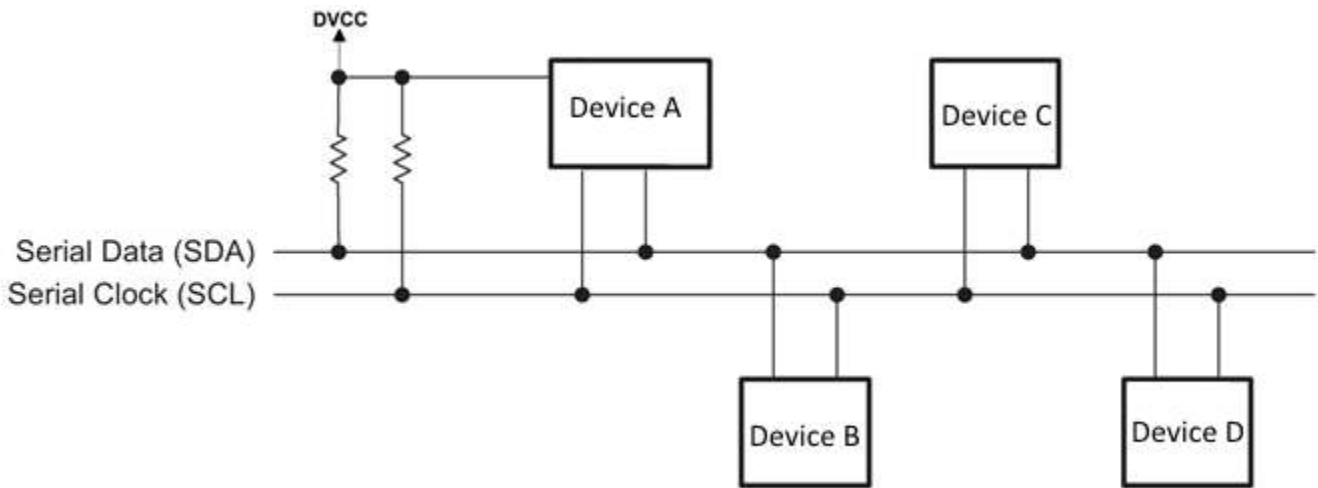

Figure 8 Development Board I2C Interface Schematic

3.6.2 I2C Device Addresses

Each I2C device is recognized by a unique address. Any additional devices added to the Dev Board I2C bus cannot replicate the existing addresses.

- U1 - Temperature Sensor - 1001111 (0x4F)
- U7 - Tri-Axis Accelerometer - 0001111 (0x0F)
- U9 - Ambient Light Sensor - 1001010 (0x4A)

3.7 External Memory

U4 on the Development Board provides a user accessible 4Mbit CMOS Serial Flash Memory, on a SPI interface to the SaBLE-x or SaBLE-x-R2 module.

3.8 LED Indicators

Several LEDs on the development board provide means of visual interface between the Development Board and the user.

- LED 1 - USB Power Indicator, Blue LED
- LED 2 - USB UART TX Data Activity, Red LED
- LED 6 - USB UART RX Data Activity, Green LED
- LED 3 - User Defined Blue LED (transistor buffered)
- LED 4 - User Defined Red LED (transistor buffered)
- LED 5 - User Defined Green LED (transistor buffered)

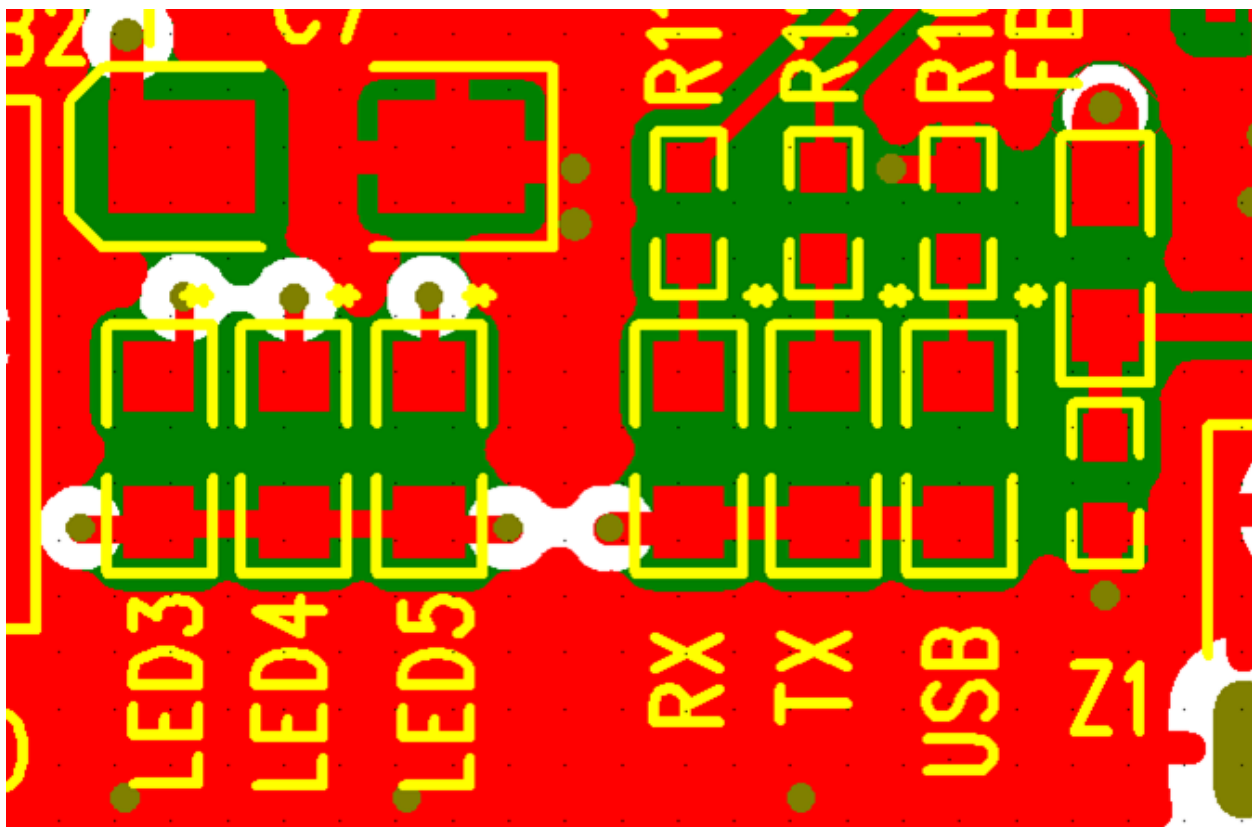

Figure 9 Development Board LEDs

4 SaBLE-x Development Board Schematics

See the LSR website for the full PCB, Schematic, and BOM of the SaBLE-x or SaBLE-x-R2 Development Board.

5 Adapter Boards

In addition to the Development Board, there are also two Adapter Boards which make it easy to adapt the Development Board to popular development platforms such as Arduino and various Texas Instruments (TI) platforms.

LSR Part Number	Description
940-0126	PCBA, SaBLE-x Dev Board to Arduino Adapter
940-0125	PCBA, SaBLE-x Dev Board to TI Adapter

Table 7 Adapter Board Part Numbers

5.1.1 Arduino Adapter Board

The SaBLE-x Dev Board to Arduino Adapter board provides a means for adapting the SaBLE-x or SaBLE-x-R2 Development Board to the open-source hardware and software of the Arduino platform. The adapter board has all the Arduino pin-headers in the standard Arduino Shield PCB form factor. In addition, the adapter board contains a 3.3V regulator and level shifter circuit to convert between logic levels of the Arduino board and the 3.3V logic level of the Arduino Adapter board.

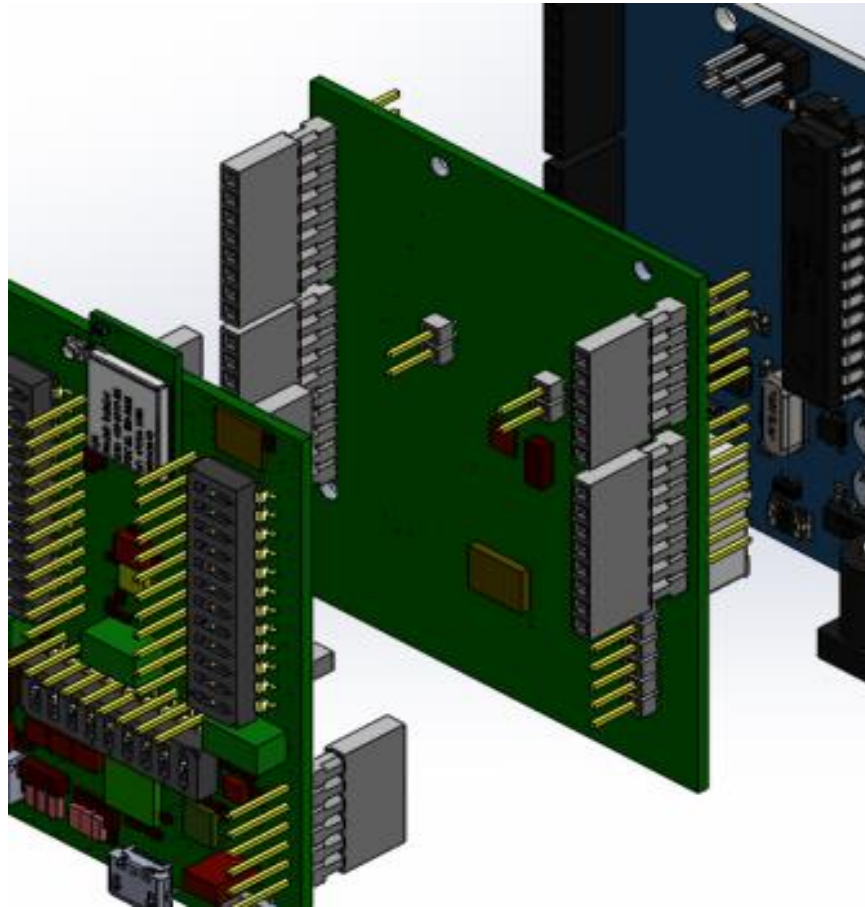

Figure 10 Arduino Adapter Platform

5.1.2 Arduino Adapter Board Connectors

J1 & J2 Pin Number	Pin Name	Module Pin Type	Description
1	NC	NC	Not Connected
2	NC	NC	Not Connected

Table 8 J1 and J2 Signals

J6 Pin Number	Pin Name	Module Pin Type	Description
1	NC	NC	Not Connected
2	NC	NC	Not Connected
3	NC	NC	Not Connected
4	NC	NC	Not Connected
5	NC	NC	Not Connected
6	NC	NC	Not Connected

Table 9 J6 Signals

J5 Pin Number	Pin Name	Module Pin Type	Description
1	3.3V	POWER	3.3V Regulated Power
2	UART TX	DIO	TX From Module (RX Arduino) – 3.3v Logic Level
3	UART RX	DIO	RX From Module (TX Arduino) – 3.3v Logic Level
4	RESET n	DIO	Module Reset (Active Low) – 3.3v Logic Level
5	BOOT ENABLE	DIO	Module Boot Enable (Active Low) – 3.3v Logic Level
6	GROUND	GND	Ground

Table 10 J5 Signals

J3 Pin Number	Pin Name	Module Pin Type	Description
1	NC	NC	Not Connected
2	NC	NC	Not Connected
3	UART TX	DIO	TX Module (RX Arduino) – Arduino Logic Level
4	NC	NC	Not Connected
5	NC	NC	Not Connected
6	NC	NC	Not Connected
7	NC	NC	Not Connected
8	NC	NC	Not Connected

Table 11 J3 Signals

The information in this document is subject to change without notice.

J4 Pin Number	Pin Name	Module Pin Type	Description
1	UART RX	DIO	RX from Module (TX Arduino) – Arduino Logic Level
2	NC	NC	Not Connected
3	NC	NC	Not Connected
4	NC	NC	Not Connected
5	NC	NC	Not Connected
6	NC	NC	Not Connected
7	GROUND	GND	Ground
8	NC	NC	Not Connected
9	NC	NC	Not Connected
10	NC	NC	Not Connected

Table 12 J4 Signals

J7 Pin Number	Pin Name	Module Pin Type	Description
1	NC	NC	Not Connected
2	GROUND	GND	Ground
3	GROUND	GND	Ground
4	5V	POWER	5V From Arduino
5	NC	NC	Not Connected
6	NC	NC	Not Connected
7	IOREF	POWER	Voltage from Arduino – Logic Level Reference
8	NC	NC	Not Connected

Table 13 J7 Signals

5.1.3 Arduino Adapter Board Schematic

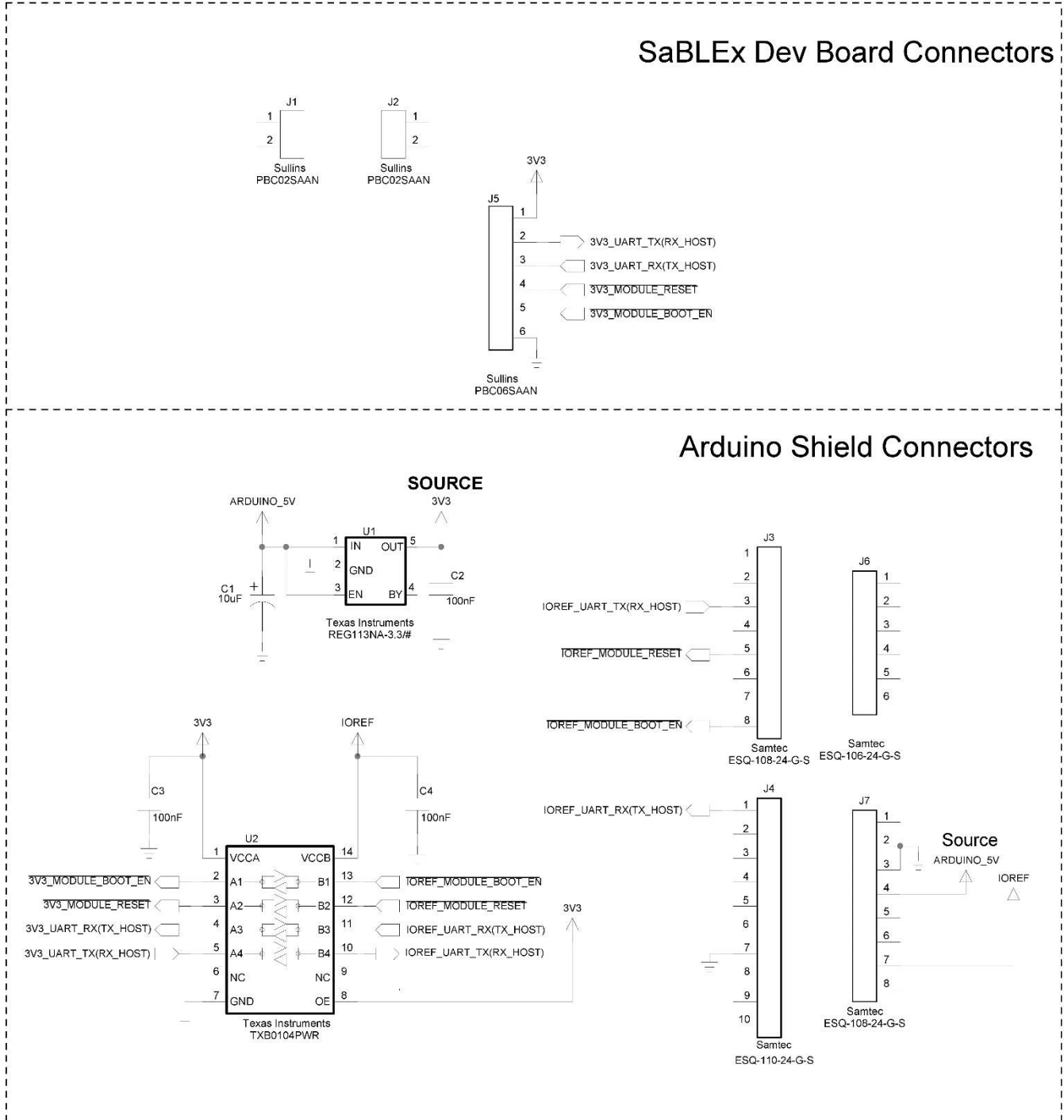

Figure 11 SaBLE-x Development Board to Arduino Adapter Schematic

5.1.4 TI Adapter Board

The SaBLE-x Dev Board to TI Adapter board provides a means for adapting the SaBLE-x or SaBLE-x-R2 Development Board to the various Texas Instruments development platforms that utilize the TI standard EM interface. Included with the LSR TI Adapter board is a break away connector board J4. J4 is required when using the Development Board with the TI SmartRF06 Evaluation Board.

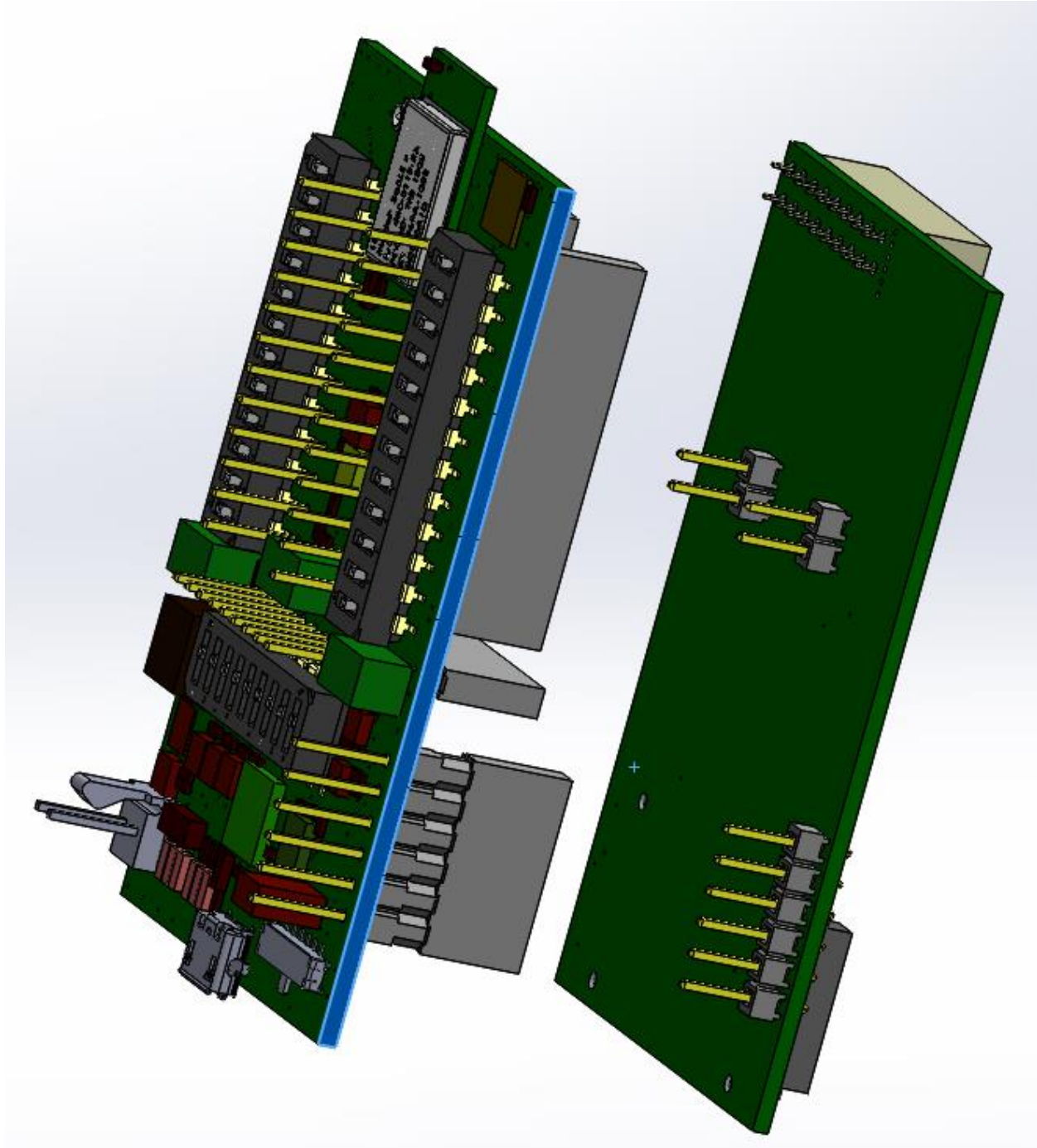

Figure 12 TI Adapter Platform (Top View)

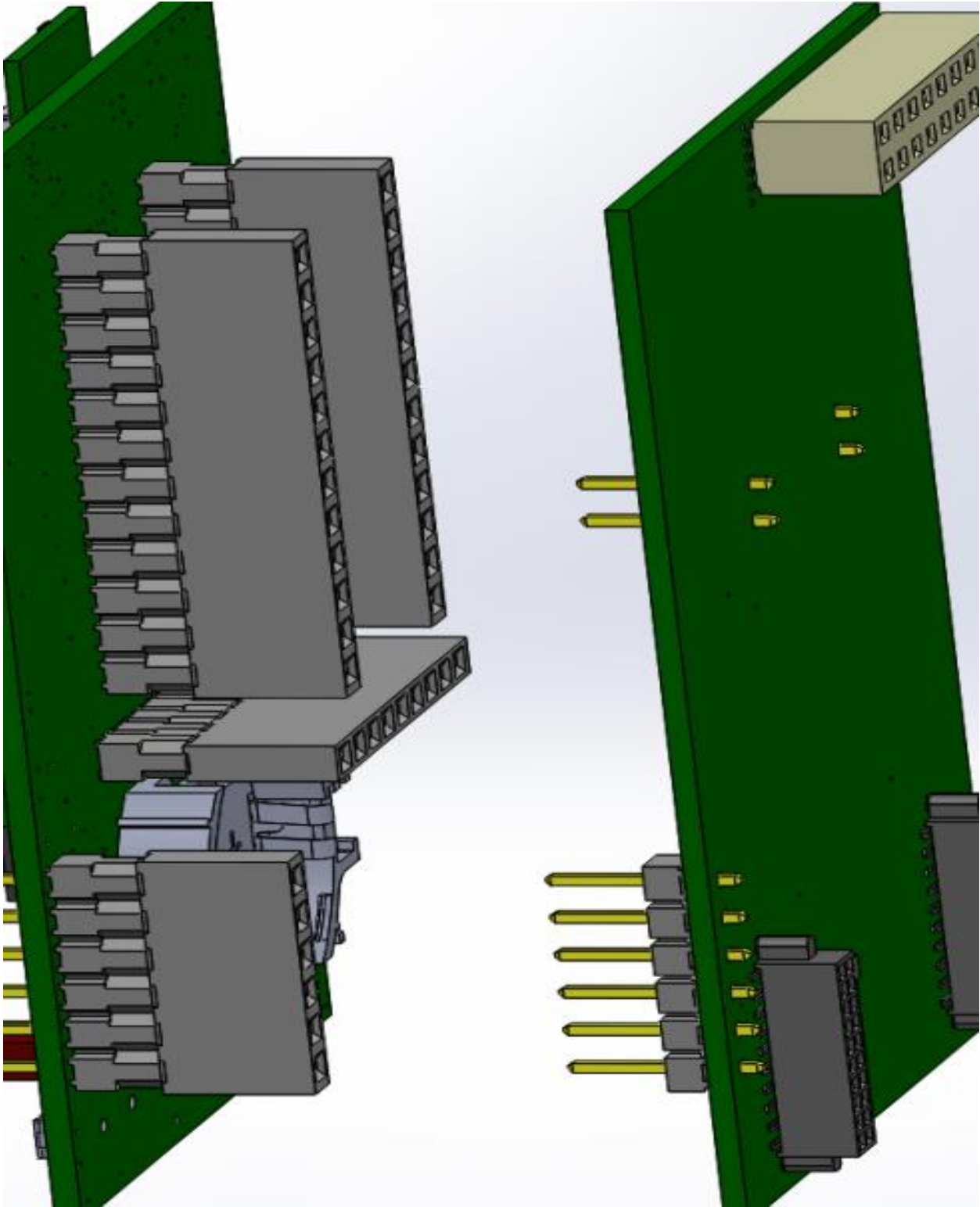

Figure 13 TI Adapter Platform (Bottom View)

5.1.5 TI Adapter Board Connectors

J5 Pin Number	Pin Name	Module Pin Type	Description
1	3.3V	POWER	3.3V From TI Eval Board
2	UART TX	DIO	TX From Module (RX TI Eval Board) – 3.3V Logic Level
3	UART RX	DIO	RX From Module (TX TI Eval Board) – 3.3V Logic Level
4	RESET n	DIO	Module Reset (Active Low) – 3.3V Logic Level
5	BOOT ENABLE	DIO	Module Boot Enable (Active Low) – 3.3V Logic Level
6	GROUND	GND	Ground

Table 14 J5 Signals

J1 Pin Number	Pin Name	Module Pin Type	Description
1	GROUND	GND	Ground
2	NC	NC	Not Connected
3	NC	NC	Not Connected
4	NC	NC	Not Connected
5	NC	NC	Not Connected
6	NC	NC	Not Connected
7	UART TX	DIO	TX From Module (RX TI Eval Board) – 3.3V Logic Level
8	NC	NC	Not Connected
9	UART RX	DIO	RX from Module (TX TI Eval Board) – 3.3V Logic Level
10	NC	NC	Not Connected
11	NC	NC	Not Connected
12	NC	NC	Not Connected
13	NC	NC	Not Connected
14	BOOT ENABLE	DIO	Module Boot Enable (Active Low) – 3.3V Logic Level
15	NC	NC	Not Connected
16	NC	NC	Not Connected
17	NC	NC	Not Connected
18	NC	NC	Not Connected
19	GROUND	GND	Ground
20	NC	NC	Not Connected

Table 15 J1 Signals

The information in this document is subject to change without notice.

J2 Pin Number	Pin Name	Module Pin Type	Description
1	JTAG TCKC	DIO	cJTAG TCK
2	GROUND	GND	Ground
3	NC	NC	Not Connected
4	JTAG TMS	DIO	cJTAG TMS
5	NC	NC	Not Connected
6	NC	NC	Not Connected
7	GROUND	GND	Ground
8	GROUND	GND	Ground
9	UART RX	DIO	RX from Module (TX TI Eval Board) – TI Logic Level
10	NC	NC	Not Connected
11	NC	NC	Not Connected
12	NC	NC	Not Connected
13	NC	NC	Not Connected
14	NC	NC	Not Connected
15	RESET n	DIO	Module Reset (Active Low) – 3.3V Logic Level
16	NC	NC	Not Connected
17	NC	NC	Not Connected
18	NC	NC	Not Connected
19	NC	NC	Not Connected
20	NC	NC	Not Connected

Table 16 J2 Signals

5.1.6 TI EM Adapter Board Schematic

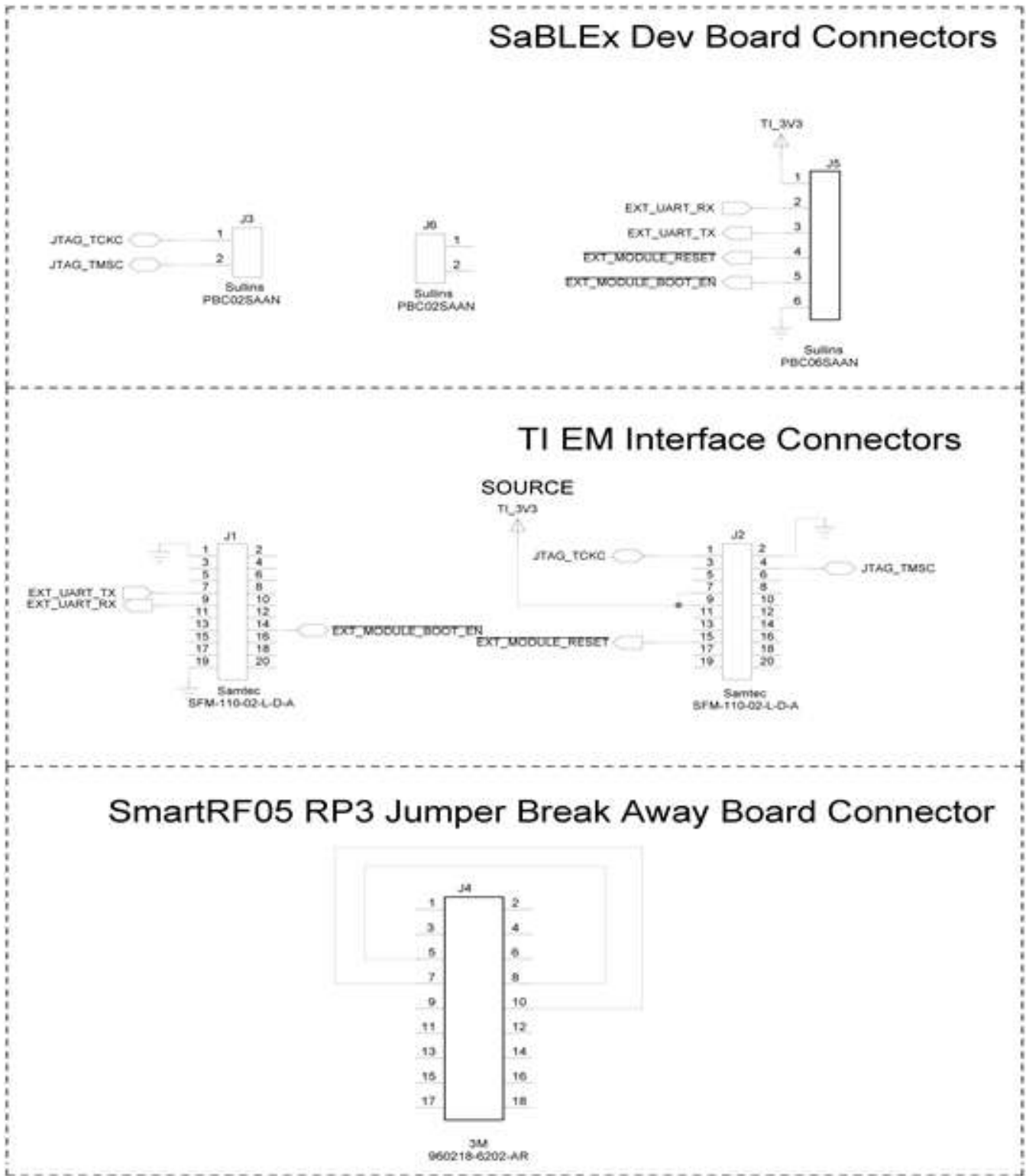

Figure 14 SaBLE-x Development Board to TI Adapter Schematic

The information in this document is subject to change without notice.

6 Evaluation and Development

6.1 Overview

The Development Board is supplied in both the Evaluation Kit and Development Kit. The Evaluation Kit includes one Development Board and is intended to be used standalone in conjunction with the LSR ModuleLink iOS and Android mobile applications. The Development Kit includes two Development Boards, and comes with both an Arduino Adapter as well as a TI Adapter. The Development Kit is intended to be more inclusive and geared toward development.

The Development Kit has been designed to support either evaluation or development, although due to the inclusion of two Development Boards and the adapters, it is tailored for development. The Development Boards included in the Development Kit used standalone for evaluation with the ModuleLink mobile apps, or for custom software development. When used with the LSR Developer Tool Suite (DTS) PC Application, the Development Boards can be commanded and controlled with the LSR Serial-to-BLE API. With two Development Boards, one can be used as a BLE Peripheral while the other is a BLE Central. The Serial-to-BLE API supports either mode that the SaBLE-x module can be used in. The advantage of using the DTS is that if the capabilities of the SaBLE-x module and the Serial-to-BLE API can be exercised and demonstrated, without the need to write any code on a host microcontroller. Once you are comfortable that the module and API will serve your needs, then you can begin your development.

Note that the SaBLE-x-R2 module does not have LSR Serial-to-BLE software, and as such does not support any of the Serial-to-BLE functionality of the DTS.

LSR's Design Services team can be contracted to assist customers with application-specific software or hardware development for SaBLE-x applications.

For an overview of development platforms and software examples see [LSR Wireless Products](#), [TI CC2640 Bluetooth Product](#), or [TI CC2640R2F Bluetooth Product](#).

6.2 Evaluation/Development Options

The evaluation and development kits provide lots of ways to help in your evaluation or development with the SaBLE-x or SaBLE-x-R2 Development Boards. Below are several examples of what you can do with the Development Boards.

6.2.1 Evaluation with a Mobile Device

With just a SaBLE-x or SaBLE-x-R2 Development Board and the ModuleLink mobile application, you can evaluate RF range, monitor button and sensor inputs, and control LED outputs.

6.2.2 Evaluation with Serial-to-BLE API and Developer Tool Suite

Note: SaBLE-x-R2 module not supported with Serial-to-BLE

Use two SaBLE-x Development Boards and two instances of the Developer Tool Suite, to evaluate the Serial-to-BLE API by communicating between the two Development Boards with one configured as a Central and the other a Peripheral. With this configuration, you can not only evaluate the Serial-to-BLE API, but you can also evaluate the SaBLE-x module capabilities without requiring a host microcontroller.

Evaluation with Serial-to-BLE API, Adapter Boards, and Host Platform

Use two SaBLE-x Development Boards, the Developer Tool Suite, either an Arduino or TI Adapter Board, and an Arduino or TI Microcontroller Development Board, to evaluate the Serial-to-BLE API by communicating between the two devices. Sample code for an Arduino or TI Microcontroller is available to get you started.

Development with Serial-to-BLE API

Use either one or two Development Boards, and your own host microcontroller to develop your application using the Serial-to-BLE API. The full API specification is available in the DTS and can be printed out for convenience. For development, it is easy to connect your host microcontroller platform to the SaBLE-x Development Boards by attaching to the pin headers.

6.2.3 Development of Custom Software

Use either one or two Development Boards, download and install the CC2640 or CC2640R2F SDK and a compatible C compiler, and start writing your own application. Downloading and debugging is possible by connecting a programmer/debugger to the programming connector on the Development Board. See Texas Instrument's CC2640 or CC2640R2F webpage for access to the SDK and extensive documentation.

SaBLE-x

The SaBLE-x module uses the CC2640. The SDK can be found here:

www.ti.com/ble-stack

SaBLE-x porting guide: <https://www.lsr.com/embedded-wireless-modules/bluetooth-module/sable-x-ble-module/porting-instructions-ti-ble-stack>

SaBLE-x-R2

The SaBLE-x-R2 module uses the CC2640R2F. The SDK can be found here:

<http://www.ti.com/tool/simplelink-cc2640r2-sdk>

SaBLE-x-R2 porting guide: <https://www.lsr.com/embedded-wireless-modules/bluetooth-module/sable-x-ble-module/sable-x-r2-porting-guide>

Note: More detailed porting guides can be found in the TI SDKs

6.3 Programming and Debugging

The SaBLE-x or SaBLE-x-R2 module can be programmed using several readily available options.

6.3.1 LSR Developer Tool Suite Wired Bootloader

The LSR Developer Tool Suite supports serially bootloading firmware images into the SaBLE-x (or SaBLE-x-R2) module through the Development Board USB interface. To use the bootloader the following switches need to be configured.

Switch	Switch Position	Signal Description
S4	USB	USB Power
S5-6	On	/Reset
S5-12	Off	VCC
S6-10	On	Boot Enable
S7-6	On	Boot RX
S7-7	On	Boot TX

Table 17 Switch Configuration for Bootloading

6.3.2 SaBLE-x Bootloader Overview

The wired bootloader in the Developer Tool Suite (DTS) takes advantage of the bootloader built into the ARM Cortex-M3 of the CC2640 (SaBLE-x) or CC2640R2F (SaBLE-x-R2). Complete information on the bootloader can be found in section 8 of the CC26xx, CC13xx SimpleLink Wireless MCU Technical Reference Manual: <http://www.ti.com/lit/pdf/swcu117>

The bootloader is configured by adjusting settings in the Customer Configuration area (CCFG). To access the bootloader, the BL_ENABLE and BOOTLOADER_ENABLE fields of the BL_CONFIG register in the CCFG area have to be set to 0xC5. This enables the bootloader backdoor so the bootloader can be entered even if there is a valid program in flash. The CC2640 or CC2640R2F determines if there is a valid image by looking at the IMAGE_VALID_CONF register.

The BL_LEVEL and BL_PIN_NUMBER fields of the BL_CONFIG register are used to configure what DIO pin is used to enter the bootloader when the CC2640 or CC2640R2F boots. All LSR firmware builds set the BL_LEVEL field to 0 so the DIO is active low. The BL_PIN_NUMBER is set to 0x09, which corresponds to DIO9 on the CC2640. To enter the bootloader when there is a valid program in flash, DIO9 needs to be driven low at reset. The capture below shows a proper sequence for entering the bootloader.

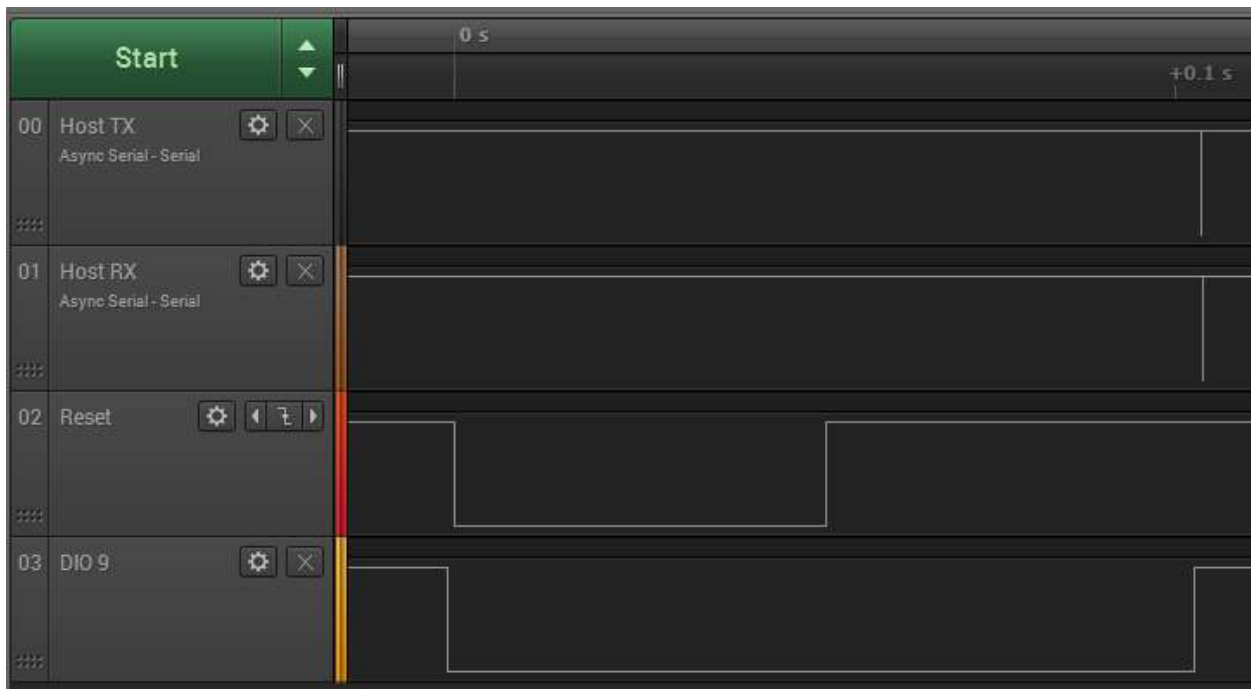

Figure 15 Enter bootloader sequence

If the user is writing their own firmware, care must be taken to setup the CCFG with the same settings to preserve the same bootloader functionality.

6.3.3 Olimex TMS320-XDS100-V3 Programmer/Debugger

For both programming and debugging (for custom firmware development) of the SaBLE-x or SaBLE-x-R2 module, the Olimex TMS320-XDS100-V3 JTAG Debugger/Programmer and Texas Instruments MDL-ADA2 adapter can be used.

The 10 Pin, .050" pitch header J8 on the SaBLE-x or SaBLE-x-R2 Development Board can be connected the XDS100 and MDL-ADA2 adapter.

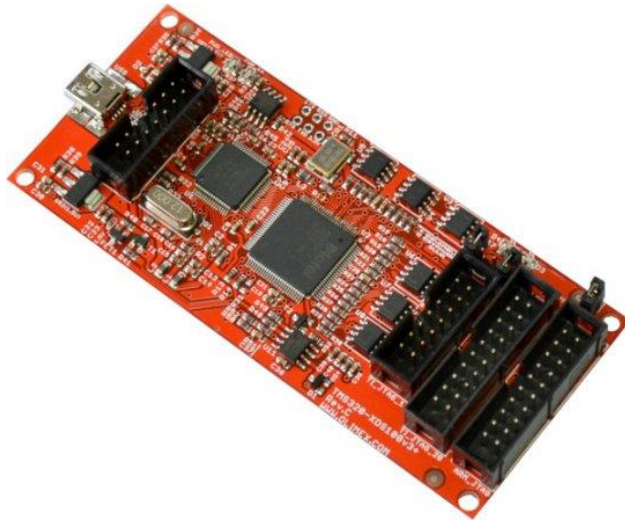

Figure 16 Olimex TMS320-XDS100-V3 JTAG Debugger/Programmer



Figure 17 TI MDL-ADA2 Adapter Module

6.3.4 TI Debug DevPack Debugger

Another option that can be used for debugging of the SaBLE-x or SaBLE-x-R2 module when developing custom firmware, is the Texas Instruments Debug DevPack (CC-DEVPACK-DEBUG, XDS110) and two Samtec FFMD-05-T-04.00.01-N cables. Like the XDS100V3, this hardware combination also connects to header J8 on the SaBLE-x or SaBLE-x-R2 Development Board. The Debug DevPack includes a free license of TI's Code Composer Studio that is tied to the DevPack. It is intended to be used when developing custom firmware applications.

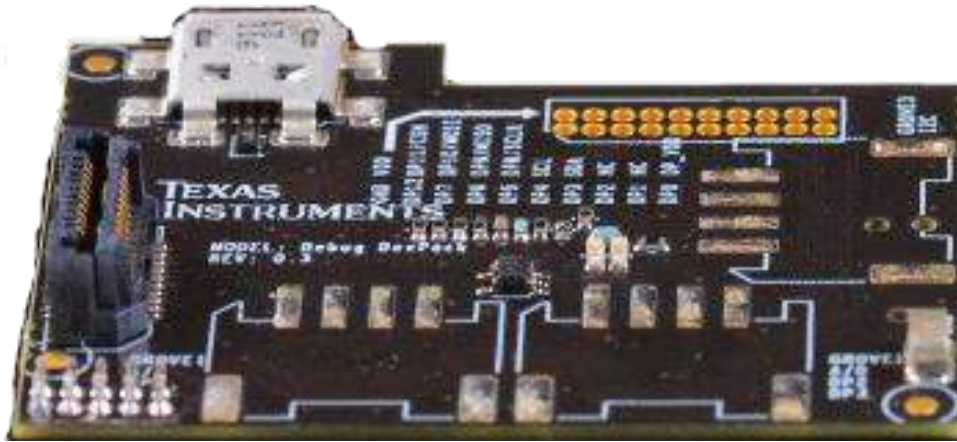

Figure 18 TI Debug DevPack

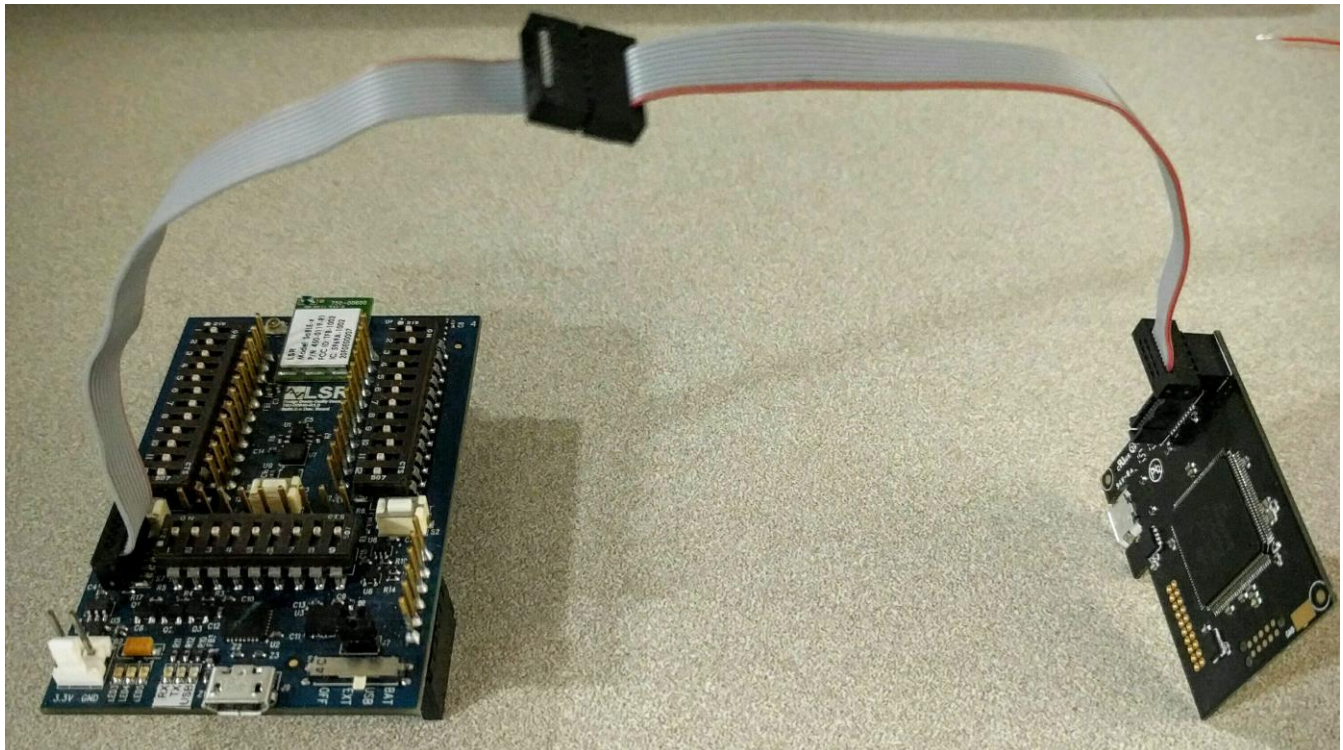

Figure 19 Debug DevPack to Dev Board Connection

The information in this document is subject to change without notice.

7 Contacting LSR

Headquarters	LSR W66 N220 Commerce Court Cedarburg, WI 53012-2636 USA Tel: 1(262) 375-4400 Fax: 1(262) 375-4248
Website	https://www.lsr.com/
Technical Support	http://info.lsr.com/contact
Sales Contact	sales@lsr.com

The information in this document is provided in connection with LS Research (hereafter referred to as “LSR”) products. No license, express or implied, by estoppel or otherwise, to any intellectual property right is granted by this document or in connection with the sale of LSR products. EXCEPT AS SET FORTH IN LSR’S TERMS AND CONDITIONS OF SALE LOCATED ON LSR’S WEB SITE, LSR ASSUMES NO LIABILITY WHATSOEVER AND DISCLAIMS ANY EXPRESS, IMPLIED OR STATUTORY WARRANTY RELATING TO ITS PRODUCTS INCLUDING, BUT NOT LIMITED TO, THE IMPLIED WARRANTY OF MERCHANTABILITY, FITNESS FOR A PARTICULAR PURPOSE, OR NON-INFRINGEMENT. IN NO EVENT SHALL LSR BE LIABLE FOR ANY DIRECT, INDIRECT, CONSEQUENTIAL, PUNITIVE, SPECIAL OR INCIDENTAL DAMAGES (INCLUDING, WITHOUT LIMITATION, DAMAGES FOR LOSS OF PROFITS, BUSINESS INTERRUPTION, OR LOSS OF INFORMATION) ARISING OUT OF THE USE OR INABILITY TO USE THIS DOCUMENT, EVEN IF LSR HAS BEEN ADVISED OF THE POSSIBILITY OF SUCH DAMAGES. LSR makes no representations or warranties with respect to the accuracy or completeness of the contents of this document and reserves the right to make changes to specifications and product descriptions at any time without notice. LSR does not make any commitment to update the information contained herein. Unless specifically provided otherwise, LSR products are not suitable for, and shall not be used in, automotive applications. LSR’s products are not intended, authorized, or warranted for use as components in applications intended to support or sustain life.

The information in this document is subject to change without notice.