

ISL8216MEVAL1Z

Evaluation Board

AN1907
Rev 0.00
February 10, 2014

Description

The ISL8216M is a simple and easy to use, high voltage DC/DC module. The ISL8216M is ideal for servers, 48V telecom/datacom applications, 12V/42V automotive and industrial equipment, and other distributed power converters/point-of-load (POL) applications. Only few passive components and a V_{OUT} setting resistor are needed for a complete a high voltage power design.

The ISL8216MEVAL1Z provides an evaluation platform for the ISL8216M. The input voltage range is from 10V to 80V, and the output voltage is preset to five options, 5V, 12V, 20V, 24V and 30V. Any other output voltages within the range from 2.5V to 30V can be set with a single resistor.

Recommended Equipment

- 10V to 80V (or other voltage rating depending on desired input voltage for the ISL8216M) power supply with at least 2A source current capability
- Electronic load capable of sinking current up to 4A
- Digital multimeters (DMMs)
- 100MHz quad-trace oscilloscope

Quick Start

1. Select the output voltage by using one of the five jumpers JP1 to JP5, for 5V, 12V, 20V, 24V or 30V.
2. Connect the VIN (J1) and PGND (J2) terminals to a power supply and connect the load to the VOUT (J4) and PGND (J3) terminals.
3. Set the input power supply to desired input voltage between 10V to 80V; note that the input voltage must be higher than the selected output voltage.
4. Enable the power supply first before turning on the load, preset the load to 0A.
5. Toggle switch SW1 to the lower position denoted "ENABLE". The PGOOD INDICATOR LED should glow in green to indicate proper operation. Use the digital multimeter to check the output voltage.

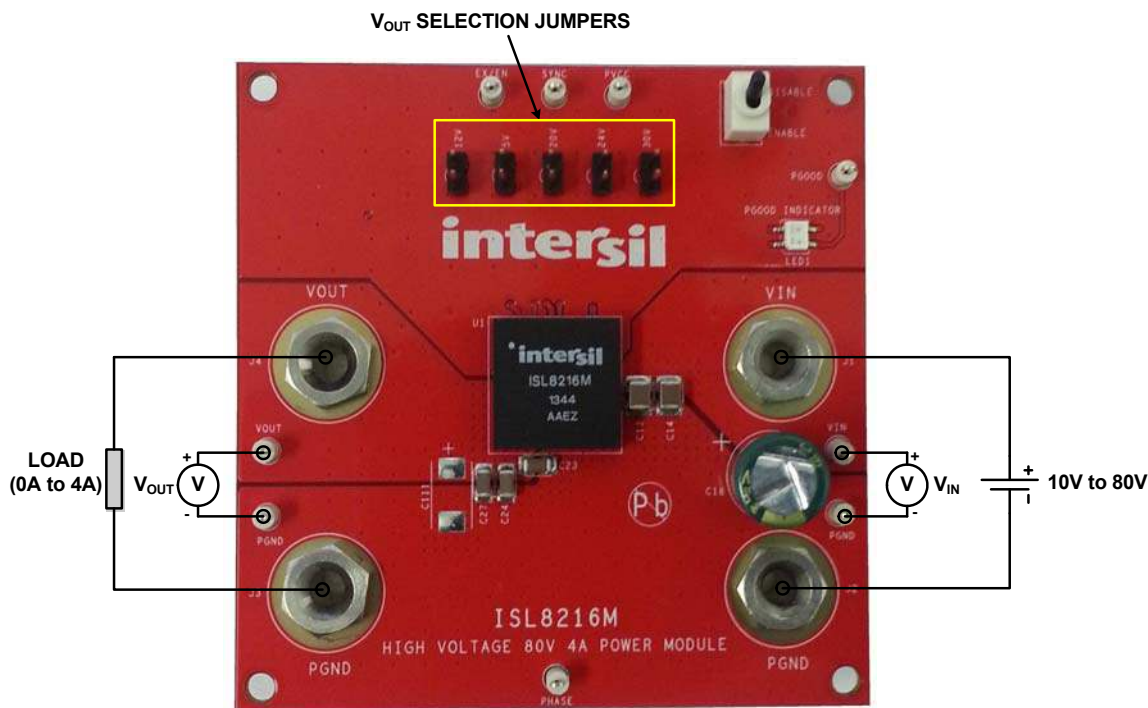

FIGURE 1. ISL8216MEVAL1Z BOARD IMAGE

Evaluation Board Information

The evaluation board size is 76.2mmx76.2mm (3 inchx3 inch). The FR4 board has four layers, with 2oz copper on the top and the bottom layers, and 1oz copper on the two internal layers. The board can be used as 4A reference design. Refer to the "ISL8216MEVAL1Z Board Schematic" on page 4 and "ISL8216MEVAL1Z Layouts" on page 5. All the components on the board, including the solder attachment, are lead free.

Circuits Description

Selecting Output Voltage

The ISL8216MEVAL1Z evaluation board has several output voltages preset for user's convenience. The 5V, 12V, 20V, 24V, and 30V can be easily selected by shorting their appropriate jumper. If any other output voltage between 2.5V and 30V is desired, the user can use a feedback resistor based on Equation 1.

$$V_{OUT} = \left(1 + \frac{11.3k\Omega}{R_{FB}}\right) \cdot 1.192V \quad (EQ. 1)$$

NOTE: The output voltage accuracy is not only dependent on the module's internal reference voltage, but also on the feedback resistance accuracy. For higher overall output accuracy, the customer should select a high accuracy resistor (i.e; 0.5%).

Programming the Switching Frequency

The ISL8216M has an internally set fixed switching frequency of 300kHz. By adding a resistor between V_{IN} and RTCT and a capacitor between RTCT and SGND, the module's switching frequency can be adjusted between 200kHz to 600kHz. The place holders for the resistor (R5) and capacitor (C5) are provided on the ISL8216MEVAL1Z evaluation board for the user's convenience. Refer to the [ISL8216M](#) datasheet for optimum switching frequency for different conditions.

The SYNC pin can provide the function to synchronize the ISL8216M's switching frequency to an external source. When frequency synchronization is used, the time constant of R_T/C_T must be set longer than the period of the sync signal. When the external sync feature is not used, the customer should tie the SYNC pin to SGND.

Optional External Enable Control Circuit

The module can be enabled by an external signal by using an open-drain device, or by adding an external circuit. This optional

external enable circuit is provided on the ISL8216MEVAL1Z evaluation board, see Figure 2.

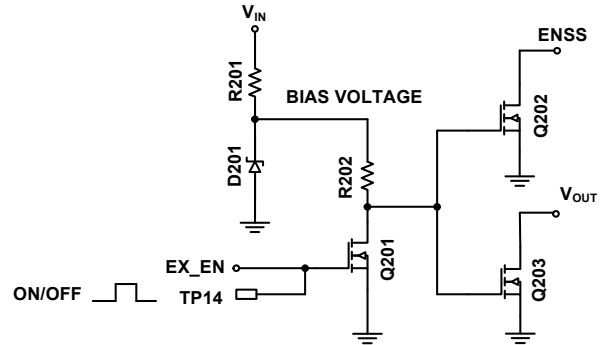

FIGURE 2. OPTIONAL EXTERNAL ENABLE CIRCUIT

To utilize the circuit shown in Figure 2, the user can place appropriate components on the place holders for R201, D201, R202, Q201, and Q202.

A bias voltage of approximately 5.1V is generated from V_{IN} with a resistor (R201) in series and a zener diode (D201). R202 is a pull-up resistor of typically 100k Ω , and Q201 and Q202 are N-MOSFETs. The external control signal is applied to TP14 (EX_EN). When EX_EN is logic low, ENSS is pulled to ground to disable the module. When EX_EN is logic high, ENSS is released to allow the module's soft-start function. The selection of R201 in series with the zener diode D201 can be calculated as shown in Equation 2:

$$R201 = \frac{V_{IN} - V_Z}{I_Z} \quad (EQ. 2)$$

Where:

- V_Z is the zener diode D201's working voltage, nominal 5.1V.
- I_Z is the zener diode D201's working reverse current, typically about 5mA.

The power dissipation rating should be taken into consideration when selecting R201.

Other External Circuits Requirements

Depending on the applications conditions, other external circuits may be required. Table 1 shows these requirements.

TABLE 1. EXTERNAL CIRCUITS REQUIREMENT BASED ON APPLICATION CONDITIONS

CONDITIONS			EXTERNAL CIRCUITS REQUIREMENTS		
V_{OUT}	Use PGOOD Signal	Enable Method	PGOOD Delay Circuit	1k Ω Dummy Load Resistor	V_{IN} -BOOT Resistor
$\leq 12V$	Yes/No	Self or External Enable Control	No	No	No
$> 12V$	Yes	Self Enable	Yes	Yes	No
$> 12V$	No	Self Enable	No	No	Yes
$> 12V$	Yes	External Enable Control	No	No	Yes
$> 12V$	No	External Enable Control	No	No	Yes

Optional PGOOD Delay Circuit

The ISL8216M has a PGOOD comparator which monitors the voltage on the FB pin. The PGOOD is asserted (open drain) when the FB pin voltage is within 14% of the reference voltage. The PGOOD is de-asserted under disable, overcurrent protection event, or over-temperature event.

As described in Table 1, a PGOOD delay circuit, as well as a dummy load resistor of 1k Ω , 1W rating, are required if all of the following conditions are met:

- V_{OUT} is higher than 12V
- PGOOD signal is utilized
- Module is self enabled/disabled

The place holders for this PGOOD delay circuit (C2, R3 and M1) and the dummy load resistor (R20) are provided on the ISL8216MEVAL1Z evaluation board for the user's convenience, as shown in Figure 3, where C2 is 1 μ F, R3 is typically 150k Ω , and M1 is an N-MOSFET. In the case where input voltage V_{IN} is not monotonic, an optional Schottky diode is recommended in parallel with resistor R3, to ensure that the capacitor C2 has been fully discharged when PVCC starts to rise from 0V.

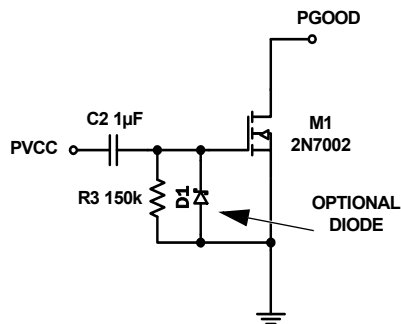

FIGURE 3. OPTIONAL PGOOD DELAY CIRCUIT WITH DIODE

For $V_{OUT} > 12V$ and light load condition, if the optional PGOOD delay circuit is not used during V_{IN} ramp up, PGOOD logic can malfunction due to low V_{OUT} as a result of bootstrap capacitor not being fully charged. This issue can be solved by adding a delay of about 250ms with this optional delay circuit.

Resistor Between V_{IN} and BOOT

As described in Table 1, a resistor between V_{IN} and BOOT is recommended if ANY of the following conditions are met:

- V_{OUT} is higher than 12V and PGOOD signal is not utilized.
- V_{OUT} is higher than 12V, PGOOD signal is utilized, and module is enabled/disabled by an external control signal.

The place holder for this resistor, R23, is provided on the ISL8216MEVAL1Z evaluation board for the user's convenience. Refer to the [ISL8216M](#) datasheet for the selection of this resistor. A minimum 0.25W power rating is recommended for this resistor.

An additional N-MOSFET along with the external enable circuit is required when R23 is populated. This N-MOSFET is used for pulling V_{OUT} to ground when the external control signal is logic low. Without this N-MOSFET, a residual voltage can be generated

on V_{OUT} capacitors due to leakage from V_{IN} , R23, internal bootstrap diode, internal bootstrap capacitor, and inductor to V_{OUT} capacitor.

Output Capacitors

The 6x22 μ F ceramic capacitors with voltage rating of 35V have been installed on the ISL8216MEVAL1Z evaluation board. However, additional place holder to add more capacitors are provided on the board for evaluating low ESR tantalum capacitor, low ESR polymer capacitor, and low ESR aluminum electrolytic capacitor. A minimum total output capacitance of 120 μ F with low ESR is recommended.

PCOMPX Pin Configuration

Control loop is already compensated internally to provide sufficient stability margins for applications with various types of output capacitors. For all ceramic output capacitors, short the PCOMPX pin to V_{OUT} ; a 0 Ω resistor R1 is provided on the evaluation board. For tantalum capacitors, polymer capacitors, or aluminum electrolytic capacitors, change R1 to resistance of lower than 1k Ω . The lower the total ESR, the lower the R1 value should be.

Radiated Emission

The ISL8216M has been evaluated with respect to CISPR 22 radio disturbance limits class B. The radiated emission test was performed with a simple input filter installed on the ISL8216MEVAL1Z evaluation board, as shown in Figure 3. Figure 15 and Figure 16 show the radiated emissions plots with respect to the CISPR 22 radio disturbance limits class B at typical operating conditions of 24V $_{IN}$ to 5V $_{OUT}$ at 4A and 24V $_{IN}$ to 12V $_{OUT}$ at 4A.

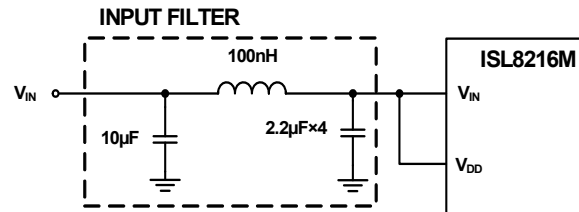

FIGURE 4. OPTIONAL INPUT FILTER FOR IMPROVED EMI PERFORMANCE

ISL8216MEVAL1Z Board Schematic

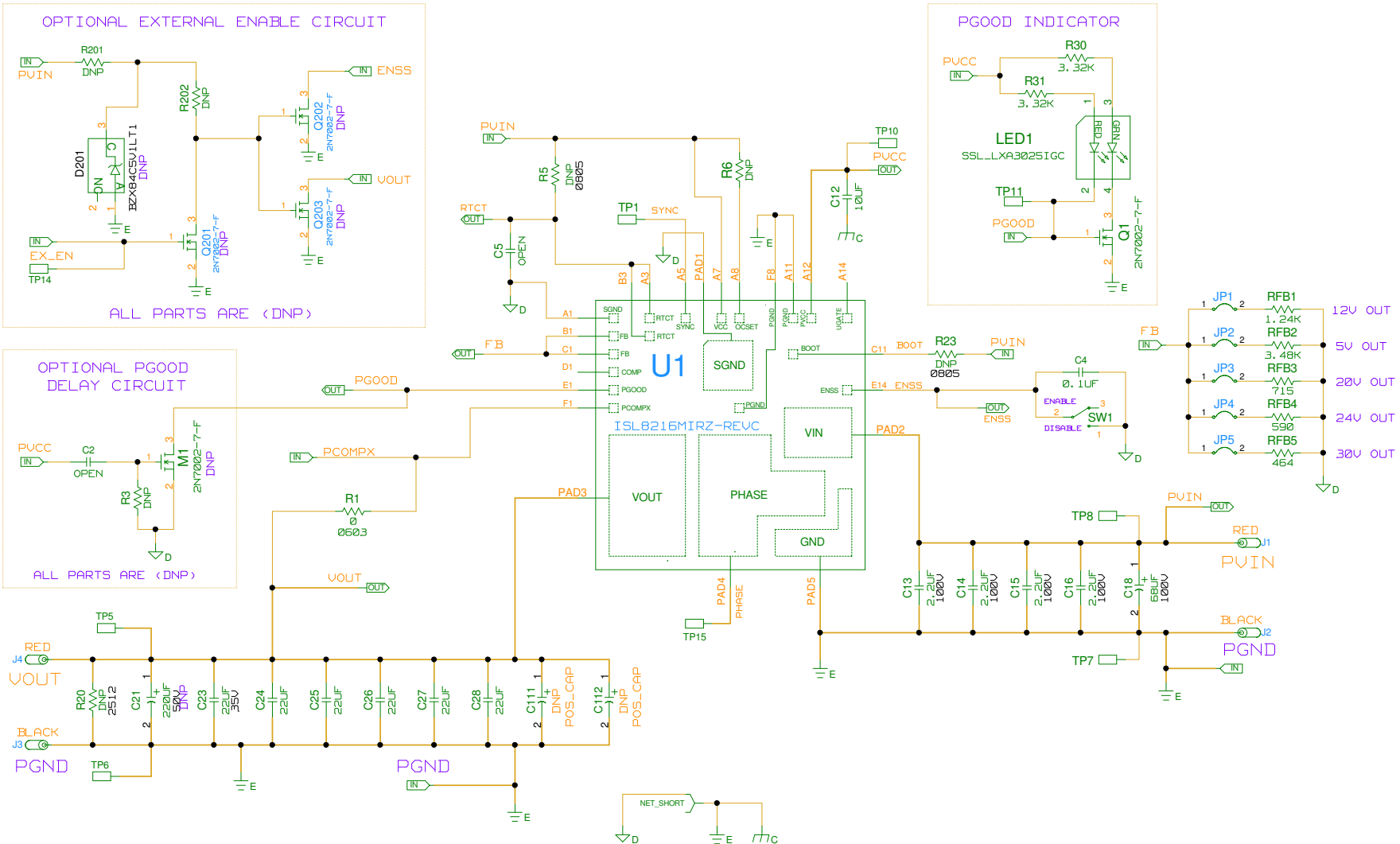

FIGURE 5. ISL8216MEVAL1Z BOARD SCHEMATIC

ISL8216MEVAL1Z Layouts

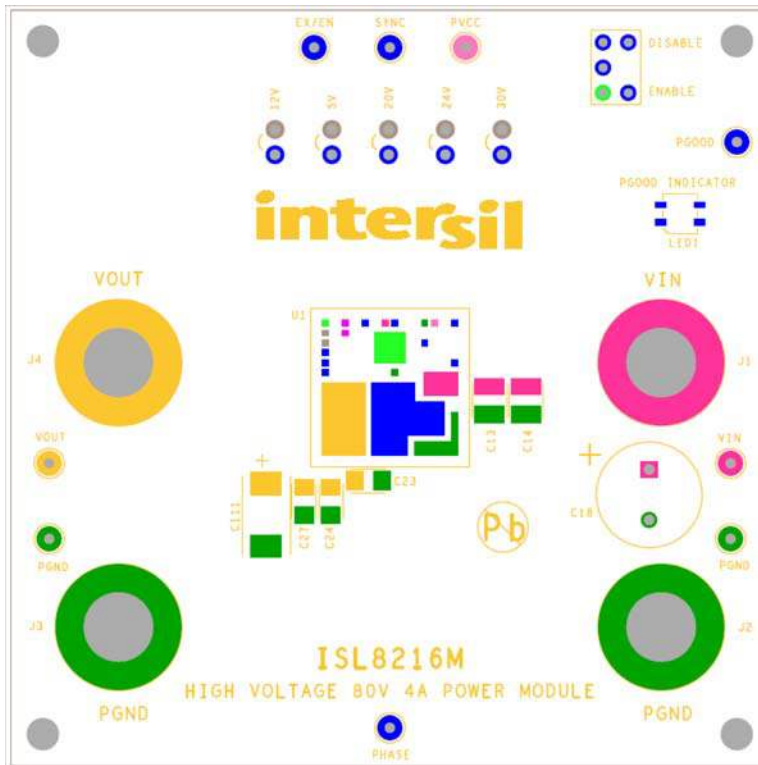

FIGURE 6. TOP SILK SCREEN

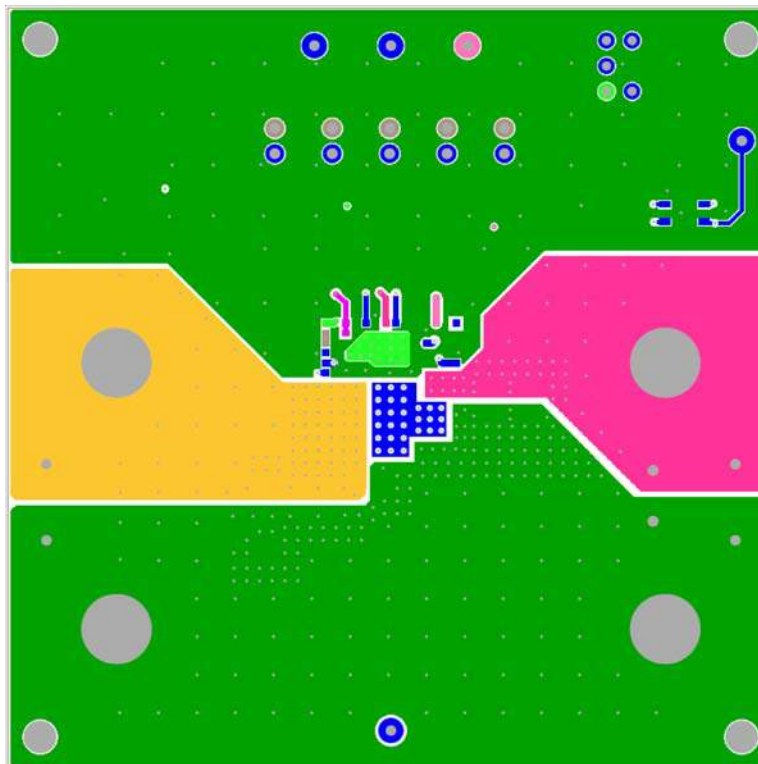

FIGURE 7. TOP LAYER COMPONENT SIDE

ISL8216MEVAL1Z Layouts (Continued)

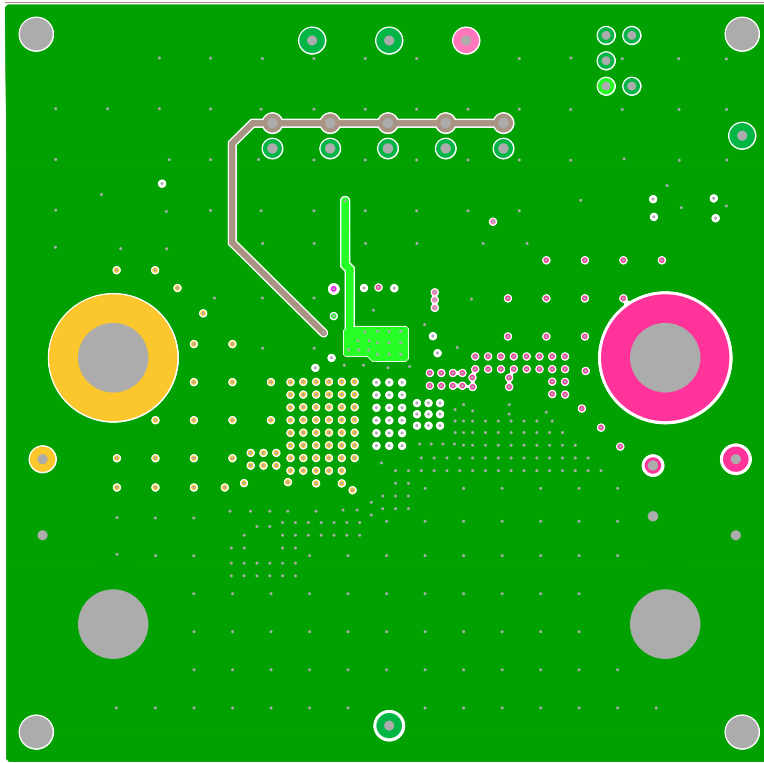

FIGURE 8. LAYER 2

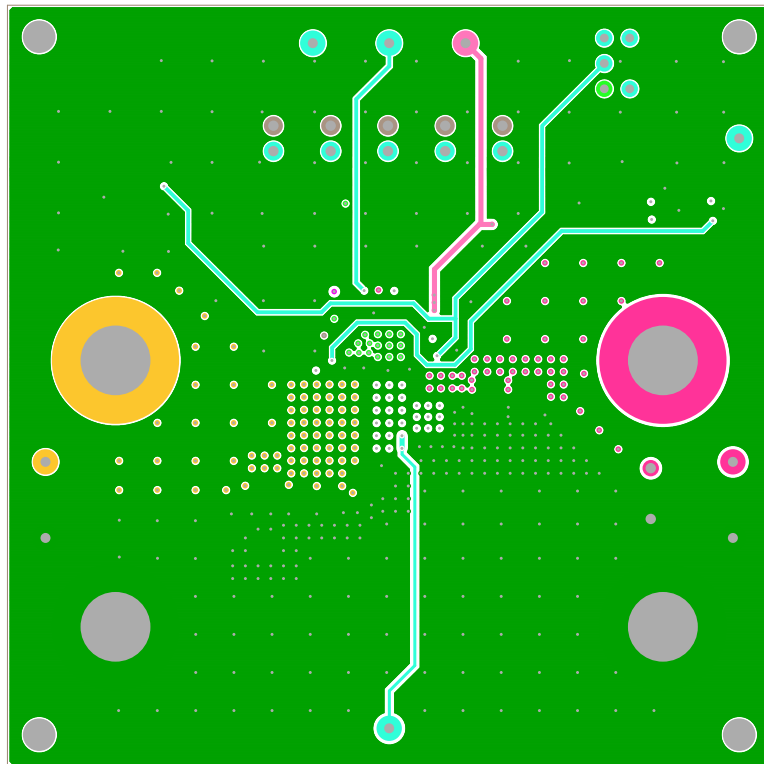

FIGURE 9. LAYER 3

ISL8216MEVAL1Z Layouts (Continued)

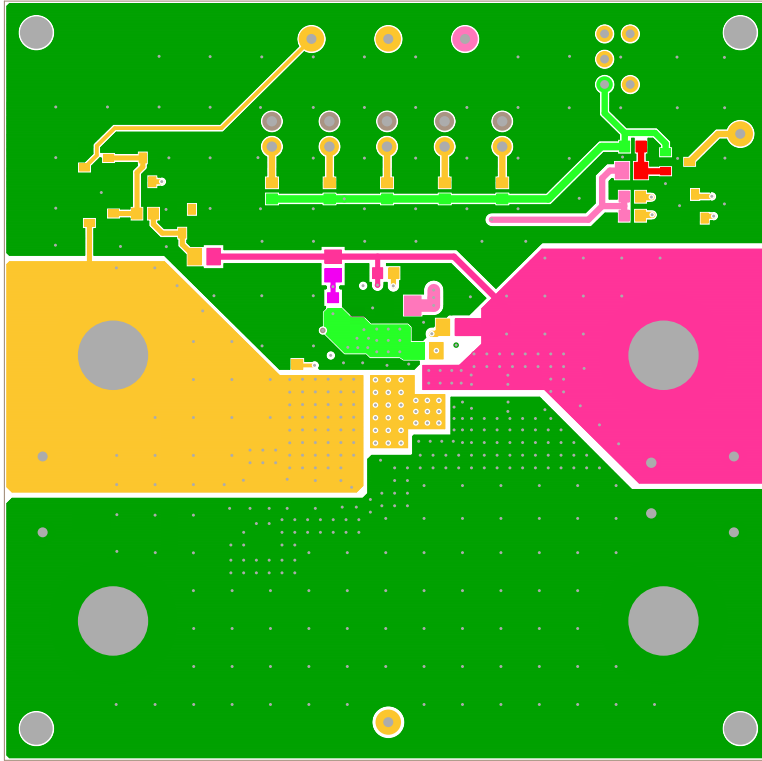

FIGURE 10. BOTTOM LAYER SOLDER SIDE

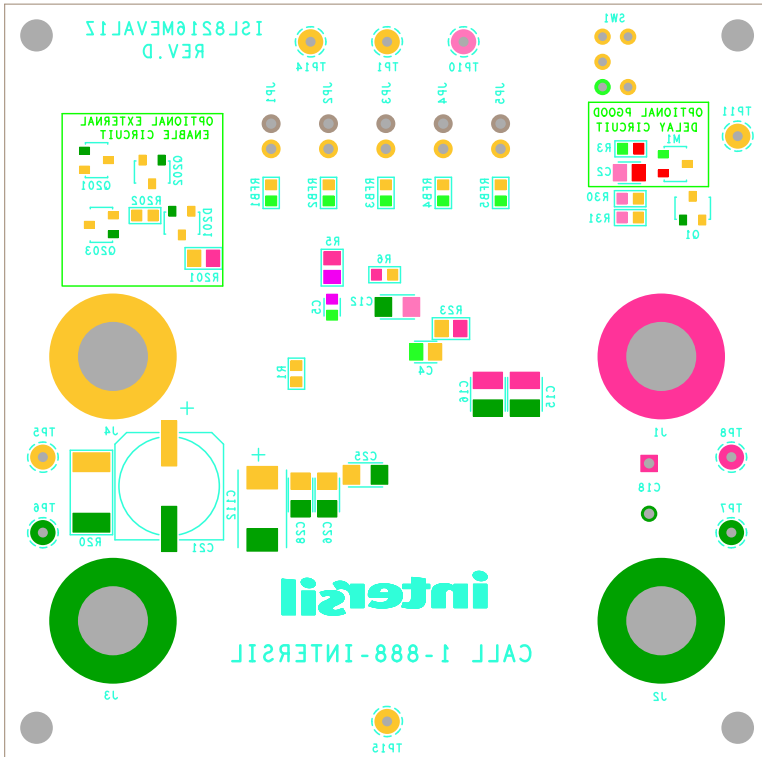

FIGURE 11. BOTTOM SILK SCREEN

Bill of Materials

PART NUMBER	REF DES	QTY	VALUE	TOL.	VOLTAGE	POWER	PACKAGE TYPE	MANUFACTURER	DESCRIPTION
H1046-00104-50V10-T	C4	1	0.1 μ F	10%	50V		805	Various	Multilayer Ceramic Capacitor
H1065-00106-25V10-T	C12	1	10 μ F	10%	25V		1206	Various	
H1082-00225-100V10-T	C13-C16	4	2.2 μ F	10%	100V		1210	Various	
100ME68AX	C18	2	68 μ F	20%	100V		THOLE	Sun Electronic Industries	Aluminum Electrolytic Capacitor
EEV-FK1H221P	C21	0	DNP				SMD		Aluminum Electrolytic Capacitors - SMD
C3216X5R1V226M160AC-T	C23-C28	6	22 μ F	20%	35V		1206	TDK	Multilayer Ceramic Capacitor
16TQC68MYF	C111, C112	0	DNP				SMD		Tantalum Capacitor - Polymer SMD
108-0740-001	J1-J4	4						Johnson Components	Banana Jack
69190-202HLF	JP1-JP5	5					THOLE	BERG/FCI	Jumper
SSL-LXA3025IGC-TR	LED1	1					SMD	LUMEX	3mmx2.5mm Surface Mount LED
2N7002-7-F-T	Q1	1					SOT-23	Various	N-Channel 60V 115mA MOSFET
H2511-00R00-1/10W-T	R1	1	0 Ω	1%		1/10W	603	Various	Thick Film Chip Resistor
H2515-DNP	R20	0	DNP				2512		
H2511-03321-1/10W1-T	R30, R31	2	3.32k Ω	1%		1/10W	603	Various	Thick Film Chip Resistor
H2511-01241-1/10W1-T	RFB1	1	1.24k Ω	1%		1/10W	603	Various	Thick Film Chip Resistor
H2511-03481-1/10W1-T	RFB2	1	3.48k Ω	1%		1/10W	603	Various	Thick Film Chip Resistor
H2511-07150-1/10W1-T	RFB3	1	715 Ω	1%		1/10W	603	Various	Thick Film Chip Resistor
H2511-05900-1/10W1-T	RFB4	1	590 Ω	1%		1/10W	603	Various	Thick Film Chip Resistor
H2511-04640-1/10W1-T	RFB5	1	464 Ω	1%		1/10W	603	Various	Thick Film Chip Resistor
GT11MCBE	SW1	1					THOLE	ITT CANNON	SPDT Toggle Switch ROHS
5002	TP1, TP5-TP8, TP10, TP11, TP14, TP15	9						Keystone	Test Point White
ISL8216MIRZ	U1	1					HDA	Intersil	15mmx15m DC/DC Power Module

Efficiency Performance

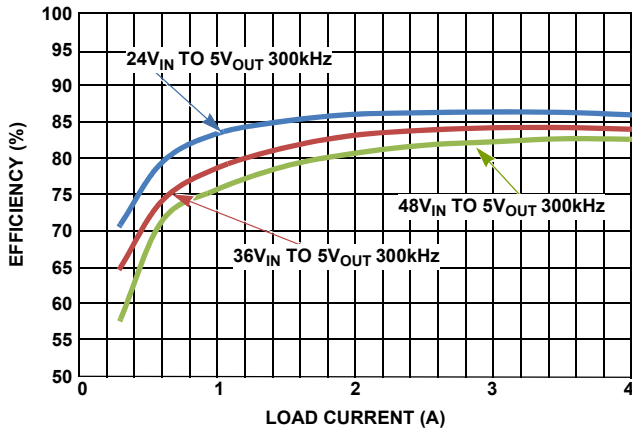

FIGURE 12. EFFICIENCY vs LOAD CURRENT (5V_{OUT} AT 300kHz)

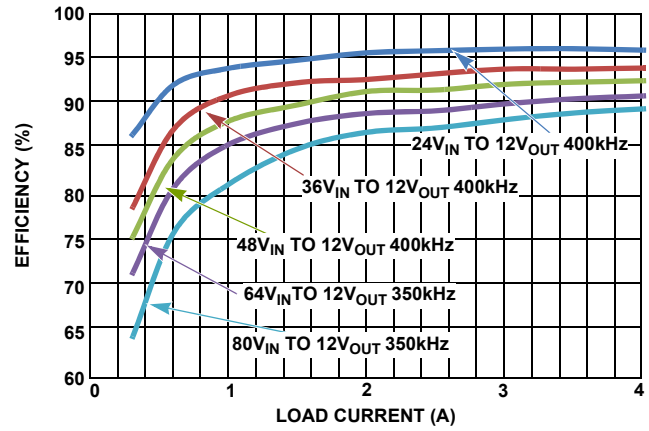

FIGURE 13. EFFICIENCY vs LOAD CURRENT (12V_{OUT})

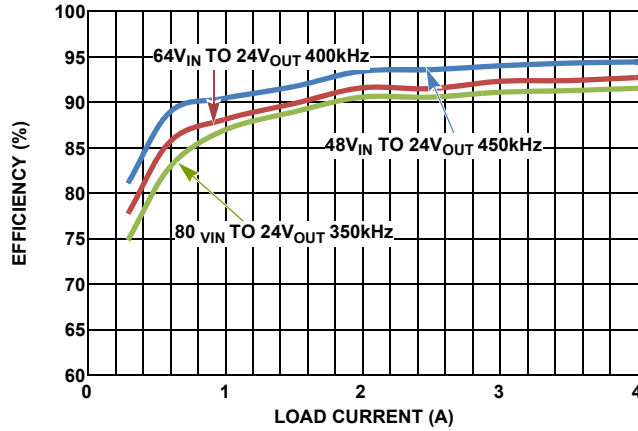

FIGURE 14. EFFICIENCY vs LOAD CURRENT (24V_{OUT})

Radiated Emission Performance

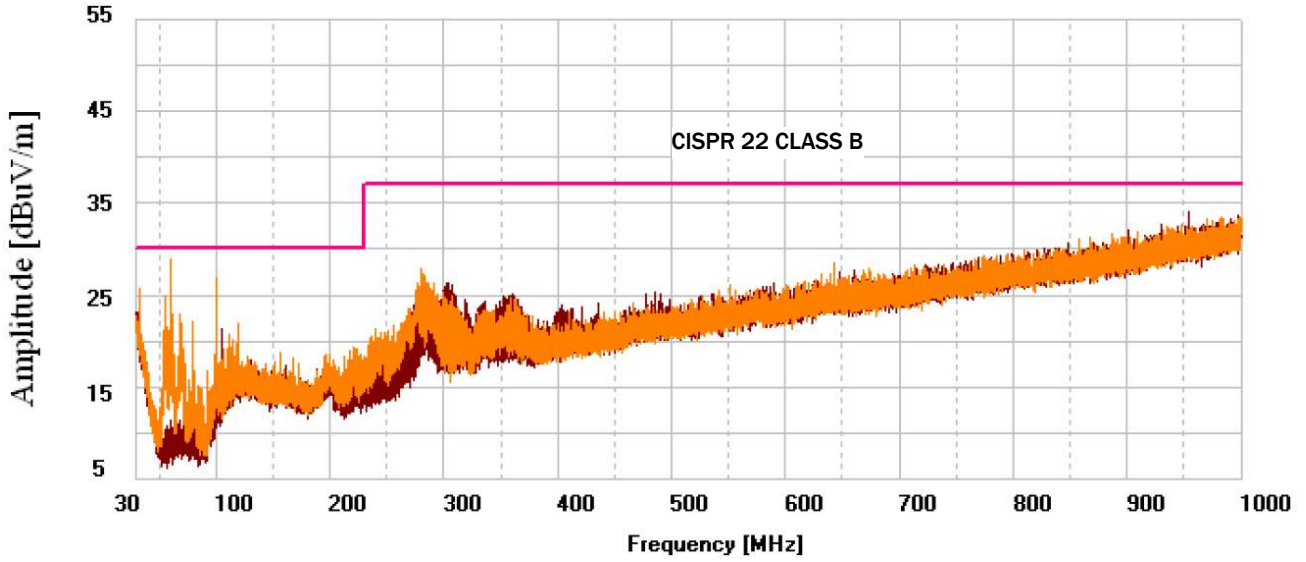

FIGURE 15. RADIATED EMISSION AT 24V_{IN} 5V_{OUT} 4A

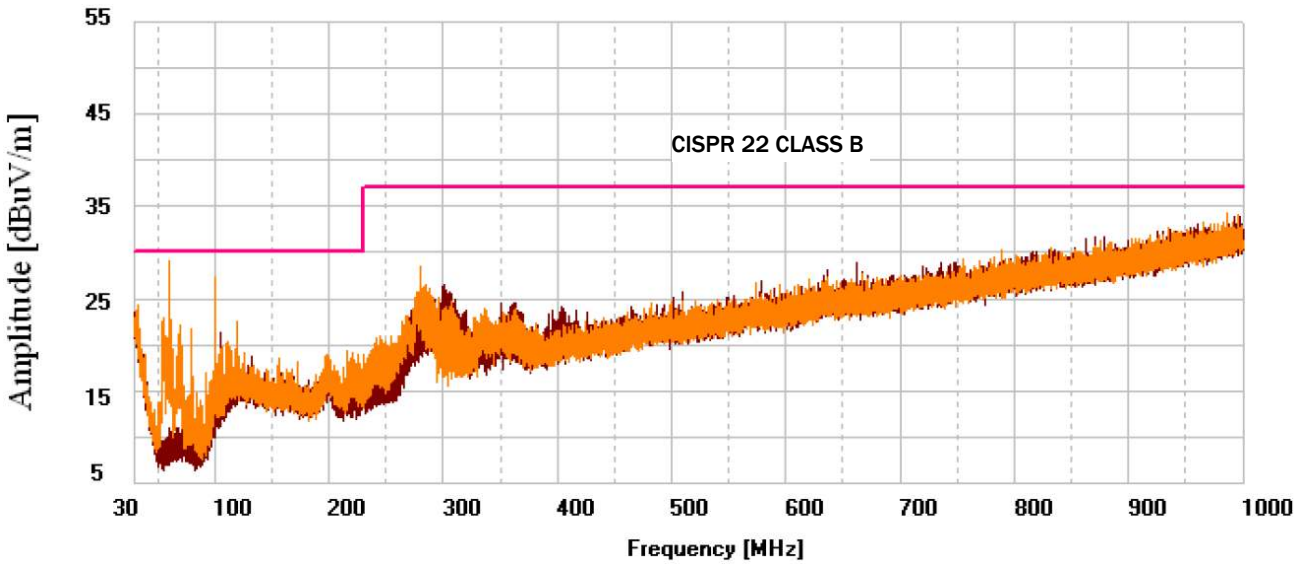

FIGURE 16. RADIATED EMISSION AT 24V_{IN} 12V_{OUT} 4A

Notice

1. Descriptions of circuits, software and other related information in this document are provided only to illustrate the operation of semiconductor products and application examples. You are fully responsible for the incorporation or any other use of the circuits, software, and information in the design of your product or system. Renesas Electronics disclaims any and all liability for any losses and damages incurred by you or third parties arising from the use of these circuits, software, or information.
2. Renesas Electronics hereby expressly disclaims any warranties against and liability for infringement or any other claims involving patents, copyrights, or other intellectual property rights of third parties, by or arising from the use of Renesas Electronics products or technical information described in this document, including but not limited to, the product data, drawings, charts, programs, algorithms, and application examples.
3. No license, express, implied or otherwise, is granted hereby under any patents, copyrights or other intellectual property rights of Renesas Electronics or others.
4. You shall not alter, modify, copy, or reverse engineer any Renesas Electronics product, whether in whole or in part. Renesas Electronics disclaims any and all liability for any losses or damages incurred by you or third parties arising from such alteration, modification, copying or reverse engineering.
5. Renesas Electronics products are classified according to the following two quality grades: "Standard" and "High Quality". The intended applications for each Renesas Electronics product depends on the product's quality grade, as indicated below.
"Standard": Computers; office equipment; communications equipment; test and measurement equipment; audio and visual equipment; home electronic appliances; machine tools; personal electronic equipment; industrial robots; etc.
"High Quality": Transportation equipment (automobiles, trains, ships, etc.); traffic control (traffic lights); large-scale communication equipment; key financial terminal systems; safety control equipment; etc.
Unless expressly designated as a high reliability product or a product for harsh environments in a Renesas Electronics data sheet or other Renesas Electronics document, Renesas Electronics products are not intended or authorized for use in products or systems that may pose a direct threat to human life or bodily injury (artificial life support devices or systems; surgical implantations; etc.), or may cause serious property damage (space system; undersea repeaters; nuclear power control systems; aircraft control systems; key plant systems; military equipment; etc.). Renesas Electronics disclaims any and all liability for any damages or losses incurred by you or any third parties arising from the use of any Renesas Electronics product that is inconsistent with any Renesas Electronics data sheet, user's manual or other Renesas Electronics document.
6. When using Renesas Electronics products, refer to the latest product information (data sheets, user's manuals, application notes, "General Notes for Handling and Using Semiconductor Devices" in the reliability handbook, etc.), and ensure that usage conditions are within the ranges specified by Renesas Electronics with respect to maximum ratings, operating power supply voltage range, heat dissipation characteristics, installation, etc. Renesas Electronics disclaims any and all liability for any malfunctions, failure or accident arising out of the use of Renesas Electronics products outside of such specified ranges.
7. Although Renesas Electronics endeavors to improve the quality and reliability of Renesas Electronics products, semiconductor products have specific characteristics, such as the occurrence of failure at a certain rate and malfunctions under certain use conditions. Unless designated as a high reliability product or a product for harsh environments in a Renesas Electronics data sheet or other Renesas Electronics document, Renesas Electronics products are not subject to radiation resistance design. You are responsible for implementing safety measures to guard against the possibility of bodily injury, injury or damage caused by fire, and/or danger to the public in the event of a failure or malfunction of Renesas Electronics products, such as safety design for hardware and software, including but not limited to redundancy, fire control and malfunction prevention, appropriate treatment for aging degradation or any other appropriate measures. Because the evaluation of microcomputer software alone is very difficult and impractical, you are responsible for evaluating the safety of the final products or systems manufactured by you.
8. Please contact a Renesas Electronics sales office for details as to environmental matters such as the environmental compatibility of each Renesas Electronics product. You are responsible for carefully and sufficiently investigating applicable laws and regulations that regulate the inclusion or use of controlled substances, including without limitation, the EU RoHS Directive, and using Renesas Electronics products in compliance with all these applicable laws and regulations. Renesas Electronics disclaims any and all liability for damages or losses occurring as a result of your noncompliance with applicable laws and regulations.
9. Renesas Electronics products and technologies shall not be used for or incorporated into any products or systems whose manufacture, use, or sale is prohibited under any applicable domestic or foreign laws or regulations. You shall comply with any applicable export control laws and regulations promulgated and administered by the governments of any countries asserting jurisdiction over the parties or transactions.
10. It is the responsibility of the buyer or distributor of Renesas Electronics products, or any other party who distributes, disposes of, or otherwise sells or transfers the product to a third party, to notify such third party in advance of the contents and conditions set forth in this document.
11. This document shall not be reprinted, reproduced or duplicated in any form, in whole or in part, without prior written consent of Renesas Electronics.
12. Please contact a Renesas Electronics sales office if you have any questions regarding the information contained in this document or Renesas Electronics products.
(Note 1) "Renesas Electronics" as used in this document means Renesas Electronics Corporation and also includes its directly or indirectly controlled subsidiaries.
(Note 2) "Renesas Electronics product(s)" means any product developed or manufactured by or for Renesas Electronics.

(Rev.4.0-1 November 2017)



SALES OFFICES

Renesas Electronics Corporation

<http://www.renesas.com>

Refer to "<http://www.renesas.com/>" for the latest and detailed information.

Renesas Electronics America Inc.
1001 Murphy Ranch Road, Milpitas, CA 95035, U.S.A.
Tel: +1-408-432-8888, Fax: +1-408-434-5351

Renesas Electronics Canada Limited
9251 Yonge Street, Suite 8309 Richmond Hill, Ontario Canada L4C 9T3
Tel: +1-905-237-2004

Renesas Electronics Europe Limited
Dukes Meadow, Millboard Road, Bourne End, Buckinghamshire, SL8 5FH, U.K
Tel: +44-1628-651-700, Fax: +44-1628-651-804

Renesas Electronics Europe GmbH
Arcadiastrasse 10, 40472 Düsseldorf, Germany
Tel: +49-211-6503-0, Fax: +49-211-6503-1327

Renesas Electronics (China) Co., Ltd.
Room 1709 Quantum Plaza, No.27 ZhichunLu, Haidian District, Beijing, 100191 P. R. China
Tel: +86-10-8235-1155, Fax: +86-10-8235-7679

Renesas Electronics (Shanghai) Co., Ltd.
Unit 301, Tower A, Central Towers, 555 Langao Road, Putuo District, Shanghai, 200333 P. R. China
Tel: +86-21-2226-0888, Fax: +86-21-2226-0999

Renesas Electronics Hong Kong Limited
Unit 1601-1611, 16/F., Tower 2, Grand Century Place, 193 Prince Edward Road West, Mongkok, Kowloon, Hong Kong
Tel: +852-2265-6688, Fax: +852-2886-9022

Renesas Electronics Taiwan Co., Ltd.
13F, No. 363, Fu Shing North Road, Taipei 10543, Taiwan
Tel: +886-2-8175-9600, Fax: +886-2-8175-9670

Renesas Electronics Singapore Pte. Ltd.
80 Bendemeer Road, Unit #06-02 Hyflux Innovation Centre, Singapore 339949
Tel: +65-6213-0200, Fax: +65-6213-0300

Renesas Electronics Malaysia Sdn.Bhd.
Unit 1207, Block B, Menara Amcorp, Amcorp Trade Centre, No. 18, Jln Persiaran Barat, 46050 Petaling Jaya, Selangor Darul Ehsan, Malaysia
Tel: +60-3-7955-9390, Fax: +60-3-7955-9510

Renesas Electronics India Pvt. Ltd.
No.777C, 100 Feet Road, HAL 2nd Stage, Indiranagar, Bangalore 560 038, India
Tel: +91-80-67208700, Fax: +91-80-67208777

Renesas Electronics Korea Co., Ltd.
17F, KAMCO Yangjae Tower, 262, Gangnam-daero, Gangnam-gu, Seoul, 06265 Korea
Tel: +82-2-558-3737, Fax: +82-2-558-5338