

This document is the property of Amphenol Corporation and is delivered on the express condition that is not to be disclosed, reproduced or used, in whole or in part, for manufacture or sale by anyone other than Amphenol Corporation without its prior consent, and that no right is granted to disclose or to use any information in this document.

The marking on this product doesn't contain environmental hazardous materials per Material Specification SS-00259 for Sony GP compliant or per directive 2011/65/EU for RoHS compliant.



ORIGINAL



REVISIONS				
SYM	ECN No.	DESCRIPTION	DATE	APPROVED
A		RELEASE FOR RoHS	05/02/2012	Arron Lin
B	NE-14040	UPDATE DRAWING FOR SHELL	03/18/2014	Arron Lin
C	NE-14187	ADD DIM	10/17/2014	Arron Lin
D	NE-16069	ADD T&R OPTION	03/30/2016	Arron Lin

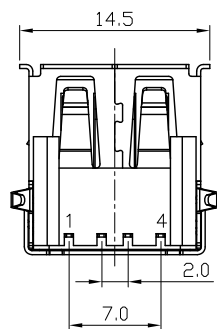
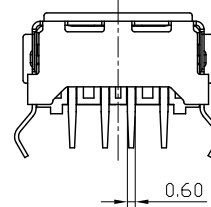
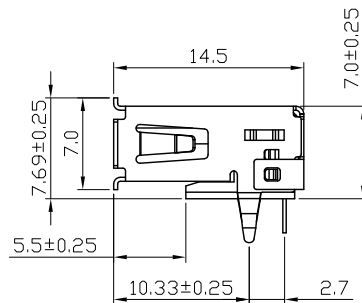
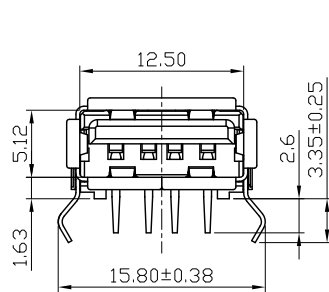
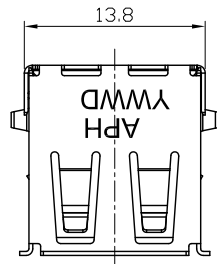
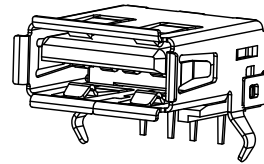

NOTES:

- INSULATOR: HTN, UL 94V-0, COLOR OPTIONS.
- CONTACT: COPPER ALLOY T=0.25mm, GOLD PLATED OPTION ON CONTACT AREA, 100μ" MIN TIN PLATED ON SOLDERING TAIL, 50μ" MIN. NICKEL UNDER PLATING OVERALL
- SHELL: SUS304 T=0.30mm, 50μ" MIN. NICKEL PLATED
- THIS PRODUCT DOESN'T CONTAIN ENVIRONMENTAL HAZARDOUS MATERIALS PER DIRECTIVE 2011/65/EU FOR RoHS.
- PACKING MUST BE PER Amphenol PACKING SPECIFICATION PKS-0001
- PRODUCT SPECIFICATION REFER TO : PS-7329

P/N: GSB121 X X RSK X HR

CONTACT FINISH  
 1: GOLD FLASH  
 2: 30u" MIN. GOLD

PACKAGE OPTION  
 BLANK: TRAY  
 R: T&R

COLOR OF INSULATOR  
 0: IVORY  
 1: BLACK

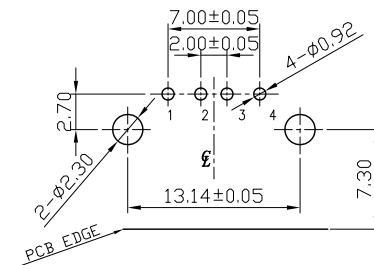

RECOMMENDED PCB LAYOUT (TOP VIEW)

TOLERANCE	APPROVALS	DATE	TITLE	UNIT	SIZE	PART No.
X. X.X ±0.30 X.XX ±0.20 X.XXX ±0.10	DRAWN Debby Hung	03/30/2016	UNIVERSAL SERIAL BUS RECEPTACLE, SERIES A STANDARD, RIGHT-ANGLE PCB MOUNT	mm	A3	GSB121XXRSKXHR
	CHECKED Roger Tsai	03/30/2016				
	APPROVED Arron Lin	03/30/2016				
ANGULAR ±1°	DWG TYPE CUST DWG	PROJECT CODE OTHER		SCALE NA	SHEET 1 OF 3	REV. D

**Amphenol**<sup>®</sup>

Amphenol Corporation  
 Amphenol Taiwan Corporation

This document is the property of Amphenol Corporation and is delivered on the express condition that it is not to be disclosed, reproduced or used, in whole or in part, for manufacture or sale by anyone other than Amphenol Corporation without its prior consent, and that no right is granted to disclose or to use any information in this document.

The marking on this product doesn't contain environmental hazardous materials per Material Specification 55-00259 for Sony GP compliant or per directive 2011/65/EU for RoHS compliant.



ORIGINAL



REVISIONS				
SYM	ECN No.	DESCRIPTION	DATE	APPROVED
A		RELEASE FOR RoHS	05/02/2012	Arron Lin
B	NE-14040	UPDATE DRAWING FOR SHELL	03/18/2014	Arron Lin
C	NE-14187	ADD DIM	10/17/2014	Arron Lin
D	NE-16069	ADD T&R OPTION	03/30/2016	Arron Lin

20 PCS  
TRAY/CARTON

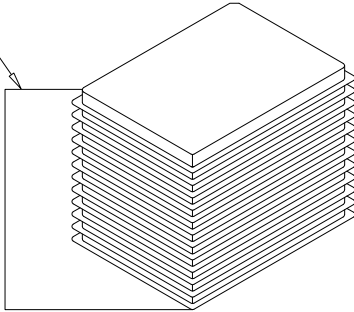

TRAY DIMENSION:  
230.0 X 220.0 X 12.7 MM.

100 PCS/TRAY

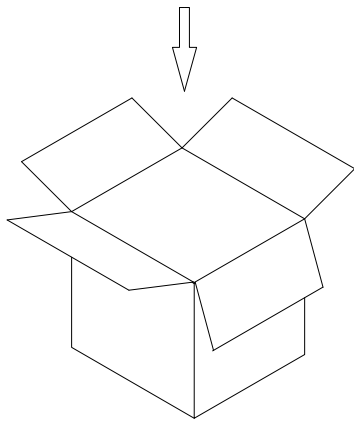

SHIPPING CARTON DIMENSION:  
520 X 273 X 310 MM.

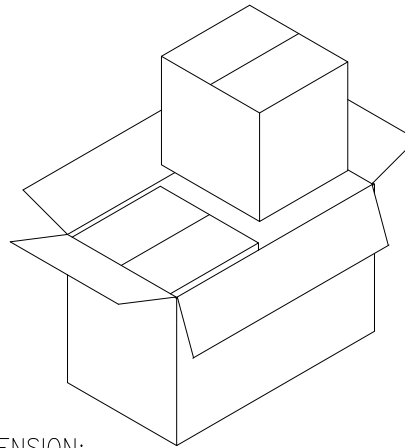

LABEL

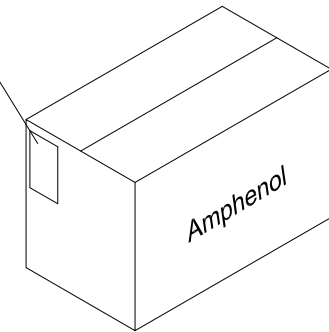

PACKAGING BY TRAY	12.2	8.2	100	20	4000	GSB121XXRSKXR
	G/W KG	N/W KG	PCS/ TRAY	TRAYS/ BOX	QUANTITY (PCS)	PART NUMBER

TOLERANCE	APPROVALS	DATE	TITLE	UNIT	SIZE	PART No.
X. ±0.30	DRAWN Debby Hung	03/30/2016	UNIVERSAL SERIAL BUS RECEPTACLE, SERIES A STANDARD, RIGHT-ANGLE PCB MOUNT	mm	A3	GSB121XXRSKXHR
X.XX ±0.20	CHECKED Roger Tsai	03/30/2016				
X.XXX ±0.10	APPROVED Arron Lin	03/30/2016				
ANGULAR ±1°	DWG TYPE CUST DWG	PROJECT CODE OTHER		SCALE NA	SHEET 2 OF 3	DWG No. GSB121XXRSKXHR
UNLESS OTHERWISE SPECIFIED						REV. D

**Amphenol**<sup>®</sup>  
Amphenol Corporation  
Amphenol Taiwan Corporation

This document is the property of Amphenol Corporation and is delivered on the express condition that is not to be disclosed, reproduced or used, in whole or in part, for manufacture or sale by anyone other than Amphenol Corporation without its prior consent, and that no right is granted to disclose or to use any information in this document.

The marking on this product doesn't contain environmental hazardous materials per Material Specification SS-00259 for Sony GP compliant or per directive 2011/65/EU for RoHS compliant.



ORIGINAL



REVISIONS				
SYM	ECN No.	DESCRIPTION	DATE	APPROVED
A		RELEASE FOR RoHS	05/02/2012	Arron Lin
B	NE-14040	UPDATE DRAWING FOR SHELL	03/18/2014	Arron Lin
C	NE-14187	ADD DIM	10/17/2014	Arron Lin
D	NE-16069	ADD T&R OPTION	03/30/2016	Arron Lin

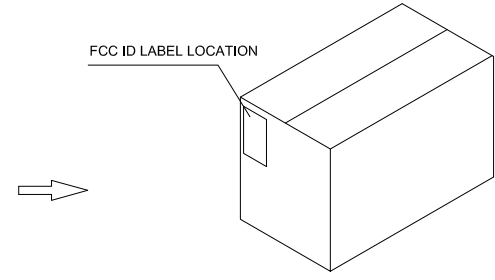
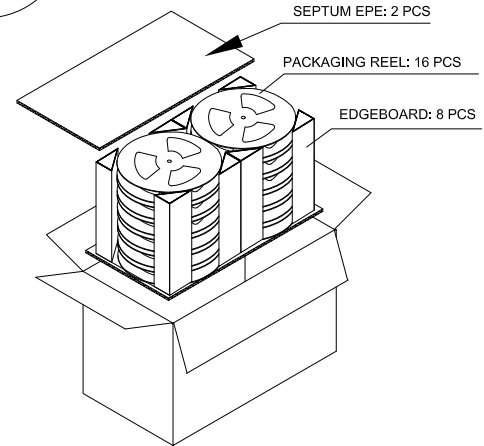
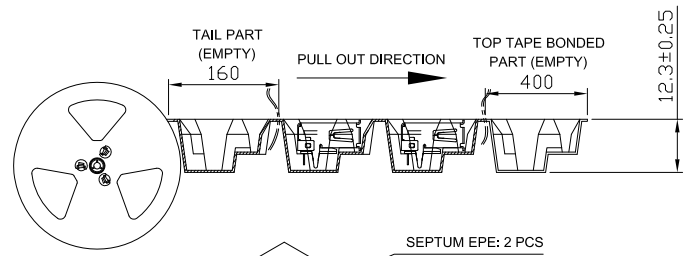
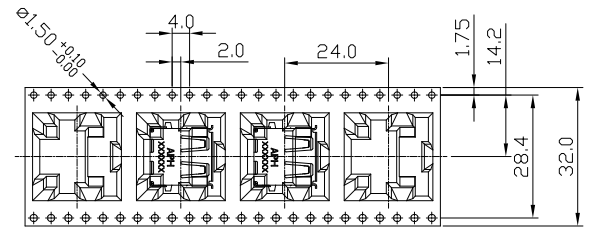

- NOTES:
1. STAPLES SHOULD ONLY BE USED TO SET UP CARTON. ALL CARTON CLOSURES MUST BE DONE WITH TAPE.
  2. FILL PACKAGING TRAYS WITH THE QUANTITIES AS INDICATED IN THE CHART.
  3. SHIPPING CARTON DIMENSION: 690 X 360 X 325mm.
  4. NET WEIGHT: 7.3 KG.  
GROSS WEIGHT: 13.6 KG.

PACKAGING BY T&R	13.6	7.3	240	16	3840	GSB121XXRSKRHR
	G/W KG	N/W KG	PCS/ REEL	REELS/ BOX	QUANTITY (PCS)	PART NUMBER

TOLERANCE	APPROVALS	DATE	TITLE	UNIT	SIZE	PART No.
X. ±0.30	DRAWN Debby Hung	03/30/2016	UNIVERSAL SERIAL BUS RECEPTACLE, SERIES A STANDARD, RIGHT-ANGLE PCB MOUNT	mm	A3	GSB121XXRSKXHR
X.XX ±0.20	CHECKED Roger Tsai	03/30/2016				
X.XXX ±0.10	APPROVED Arron Lin	03/30/2016		NA	3 OF 3	GSB121XXRSKXHR
ANGULAR ±1°	DWG TYPE CUST DWG	PROJECT CODE OTHER				
UNLESS OTHERWISE SPECIFIED						

**Amphenol**<sup>®</sup>  
Amphenol Corporation  
Amphenol Taiwan Corporation