

# FS6X1220R

## Fairchild Power Switch (FPS™)

### Features

- Current Mode PWM Control With a Fixed Operating Frequency (300kHz)
- Pulse by Pulse Current Limit
- Over Load Protection
- Over Voltage Protection
- Thermal Shutdown
- Built-in Auto-Restart Circuit
- Line Under Voltage Detection and Sleep on/off Function
- Internal High Voltage SenseFET (QFET)
- Supports Forward or Flyback Topology

### Application

- DC-DC Converter

### Description

The FS6X1220R is specially designed for an off-line DC-DC converters with minimal external components. This device is a current mode PWM controller combined with a high voltage power SenseFET in a single package. The PWM controller includes integrated fixed frequency oscillator, line under voltage lockout, sleep on/off function, thermal shutdown protection, over voltage protection, pulse-by-pulse current limit and temperature compensated precise current sources for a loop compensation. Compared with discrete MOSFET and PWM controller solution, the FS6X1220R can reduce total cost, component count, size and weight simultaneously increasing efficiency, productivity, and system reliability. This device is well suited for DC to DC converter applications up to 40W of output power.



### Internal Block Diagram

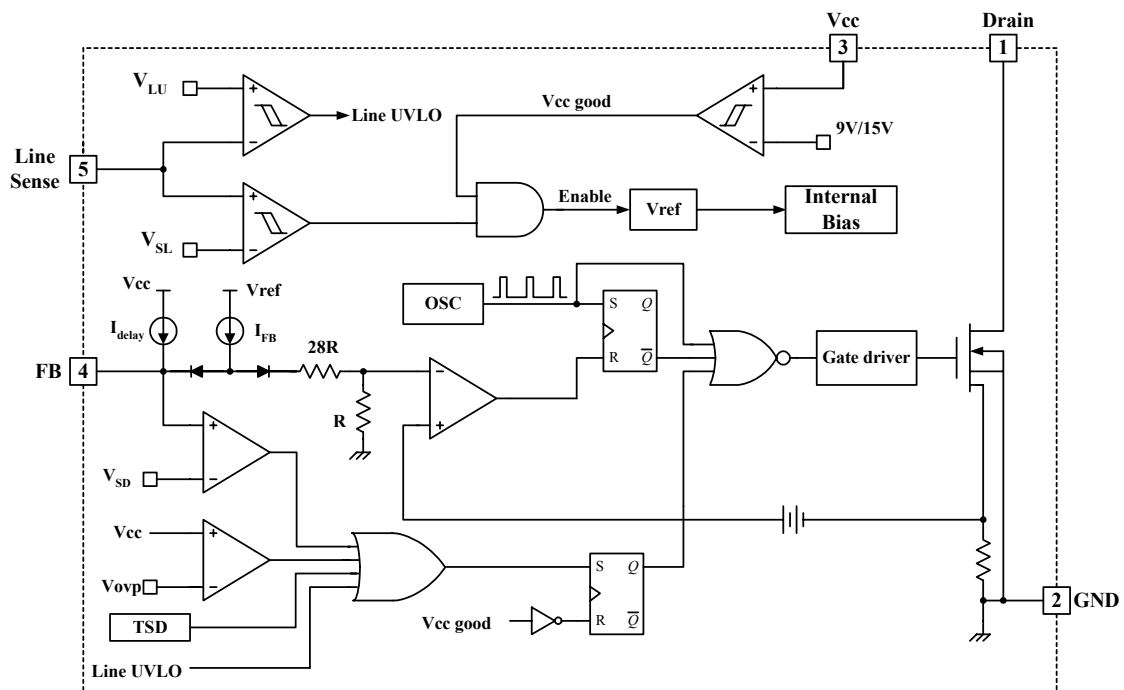

---

## Pin Description

Pin Number	Pin Name	Pin Function Description
1	Drain	High voltage power SenseFET drain connection.
2	GND	This pin is the control ground and the SenseFET source.
3	Vcc	This pin is the positive supply input. This pin provides internal operating current for both start-up and steady-state operation.
4	Feedback (FB)	This pin is internally connected to the inverting input of the PWM comparator. The collector of an opto-coupler is typically tied to this pin. For stable operation, a capacitor should be placed between this pin and GND. If the voltage of this pin reaches 7.5V, the over load protection is activated resulting in shutdown of the IC.
5	Line Sense (LS)	According to the voltage of this pin, three operation modes are defined; Normal operation mode, Line under voltage lock out mode and Sleep mode. If the voltage of this pin is smaller than 2.55V, the IC goes into line under voltage lock out stopping switching operation. If the voltage of this pin is smaller than 1.8V, the IC enters into sleep mode. During sleep mode, reference voltage generation circuit including shunt regulator is disabled and only 300uA operation current is required.

## Absolute Maximum Ratings

(Ta=25°C, unless otherwise specified)

Parameter	Symbol	Value	Unit
Drain-Gate Voltage (R <sub>GS</sub> =1MΩ)	V <sub>DGR</sub>	200	V
Gate-Source (GND) Voltage	V <sub>GS</sub>	±30	V
Drain Current Pulsed <sup>(2)</sup>	I <sub>DM</sub>	32.8	ADC
Single Pulsed Avalanche Energy <sup>(3)</sup>	E <sub>AS</sub>	210	mJ
Continuous Drain Current (T <sub>c</sub> = 25°C)	I <sub>D</sub>	8.2	ADC
Continuous Drain Current (T <sub>C</sub> =100°C)	I <sub>D</sub>	5.2	ADC
Supply Voltage	V <sub>CC</sub>	35	V
Input Voltage Range	V <sub>FB</sub>	-0.3 to V <sub>CC</sub>	V
	V <sub>LS</sub>	-0.3 to V <sub>CC</sub>	V
Total Power Dissipation	P <sub>D</sub> (Watt H/S)	45	W
	Derating	0.36	W/°C
Operating Junction Temperature	T <sub>j</sub>	+150	°C
Operating Ambient Temperature	T <sub>A</sub>	-25 to +85	°C
Storage Temperature Range	T <sub>STG</sub>	-55 to +150	°C

### Notes:

1. T<sub>j</sub>=25°C to 150°C
2. Repetitive rating: Pulse width limited by maximum junction temperature
3. L=4.7 mH, starting T<sub>j</sub>=25°C

## Electrical Characteristics (SenseFET part)

(Ta=25°C unless otherwise specified)

Parameter	Symbol	Condition	Min.	Typ.	Max.	Unit
Drain Source Breakdown Voltage	BVDSS	VGS=0V, ID=250μA	200	-	-	V
Zero Gate Voltage Drain Current	IDSS	VDS=200V, VGS=0V	-	-	50	μA
		VDS=160V VGS=0V, TC=125°C	-	-	200	μA
Static Drain Source On Resistance <sup>(1)</sup>	RDS(ON)	VGS=10V, ID=4.1A	-	0.24	0.30	Ω
Forward Transconductance	gfs	VDS=40V, ID=4.1A	-	7.1	-	mho
Input Capacitance	Ciss	VGS=0V, VDS=25V, f = 1MHz	-	700	910	pF
Output Capacitance	Coss		-	125	160	
Reverse Transfer Capacitance	Crss		-	18	25	
Turn On Delay Time	td(on)	VDD=100V, ID=11.6A (MOSFET switching time is essentially independent of operating temperature)	-	13	35	ns
Rise Time	tr		-	120	250	
Turn Off Delay Time	td(off)		-	30	70	
Fall Time	tf		-	55	120	
Total Gate Charge (Gate-Source+Gate-Drain)	Qg	VGS=10V, ID=11.6A, VDS=160V (MOSFET switching time is essentially independent of operating temperature)	-	18	23	nC
Gate-Source Charge	Qgs		-	5	-	
Gate-Drain (Miller) Charge	Qgd		-	8	-	

**Note:**

1. Pulse test : Pulse width ≤ 300μS, duty ≤ 2%

**Electrical Characteristics** (Continued)

(Ta=25°C unless otherwise specified)

Parameter	Symbol	Condition	Min.	Typ.	Max.	Unit
<b>UVLO SECTION</b>						
Start Threshold Voltage	V <sub>START</sub>	V <sub>FB</sub> = GND	14	15	16	V
Stop Threshold Voltage	V <sub>STOP</sub>	V <sub>FB</sub> = GND	8	9	10	V
<b>OSCILLATOR SECTION</b>						
Initial Frequency	F <sub>OSC</sub>	-	270	300	330	kHz
Voltage Stability	F <sub>STABLE</sub>	12V ≤ V <sub>CC</sub> ≤ 23V	0	1	3	%
Temperature Stability (1)	ΔF <sub>OSC</sub>	-25°C ≤ Ta ≤ 85°C	0	±5	±10	%
Maximum Duty Cycle	D <sub>MAX</sub>	-	72	80	88	%
Minimum Duty Cycle	D <sub>MIN</sub>	-	-	-	0	%
<b>FEEDBACK SECTION</b>						
Feedback Source Current	I <sub>FB</sub>	V <sub>FB</sub> = GND	0.7	0.9	1.1	mA
Shutdown Feedback Voltage	V <sub>SD</sub>	V <sub>FB</sub> ≥ 6.9V	6.9	7.5	8.1	V
Shutdown Delay Current	I <sub>DELAY</sub>	V <sub>FB</sub> = 5V	4.0	5.0	6.0	μA
<b>LINE SENSE SECTION</b>						
Line UVLO Threshold Voltage	V <sub>LU</sub>	-	2.4	2.55	2.7	V
Sleep On/Off Threshold Voltage	V <sub>SL</sub>	-	1.5	1.8	2.1	V
<b>CURRENT LIMIT(SELF-PROTECTION)SECTION</b>						
Peak Current Limit (2)	I <sub>OVER</sub>	-	2.82	3.2	3.58	A
<b>PROTECTION SECTION</b>						
Thermal Shutdown Temp (1)	T <sub>SD</sub>	-	140	160	-	°C
Over Voltage Protection	V <sub>OV</sub> P	V <sub>CC</sub> ≥ 6.9V	23	25	27	V
<b>TOTAL DEVICE SECTION</b>						
Start Up Current	I <sub>START</sub>	V <sub>FB</sub> = GND, V <sub>CC</sub> = 14V	-	60	120	μA
Sleep Mode Current	I <sub>SLEEP</sub>	V <sub>UVLO</sub> = 1V, V <sub>CC</sub> = 16V	-	300	500	μA
Operating Supply Current	I <sub>OP</sub>	V <sub>FB</sub> = GND, V <sub>CC</sub> = 16V	-	10	15	mA
	I <sub>OP(MIN)</sub>	V <sub>FB</sub> = GND, V <sub>CC</sub> = 12V				
	I <sub>OP(MAX)</sub>	V <sub>FB</sub> = GND, V <sub>CC</sub> = 20V				

**Note:**

1. These parameters, although guaranteed at the design, are not tested in mass production.
2. These parameter indicates inductor current.

## Typical Performance Characteristics

(These Characteristic Graphs are Normalized at Ta= 25°C)

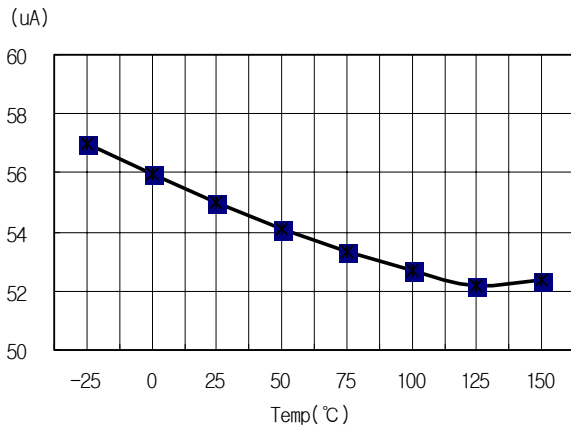

Figure 1. Start Up Current vs. Temp.

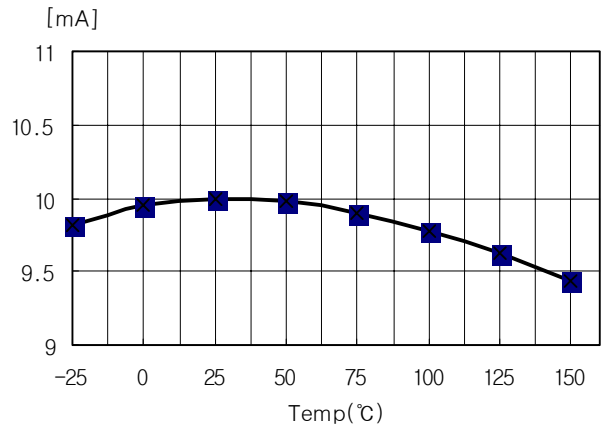

Figure 2. Operating Supply Current vs. Temp.

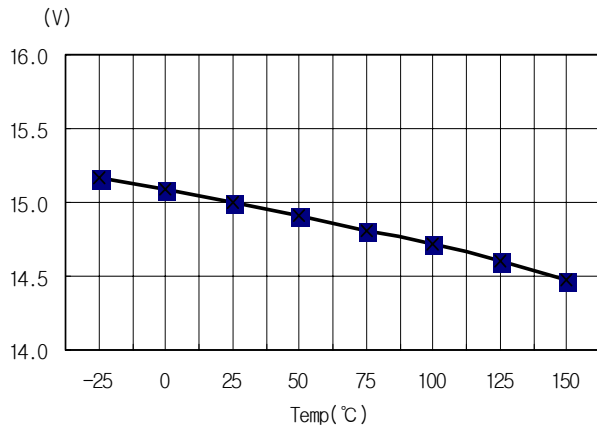

Figure 3. Start Threshold Voltage vs. Temp.

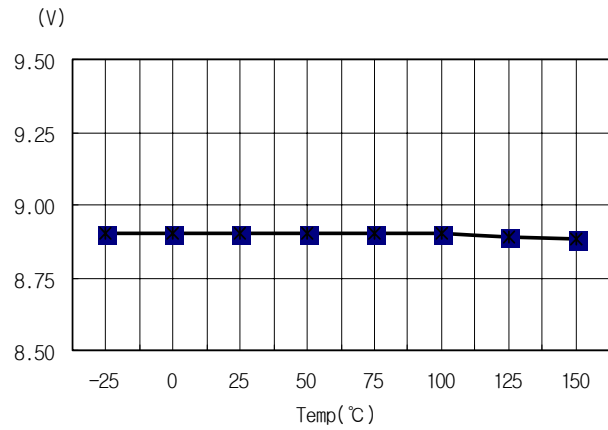

Figure 4. Stop Threshold Voltage vs. Temp.

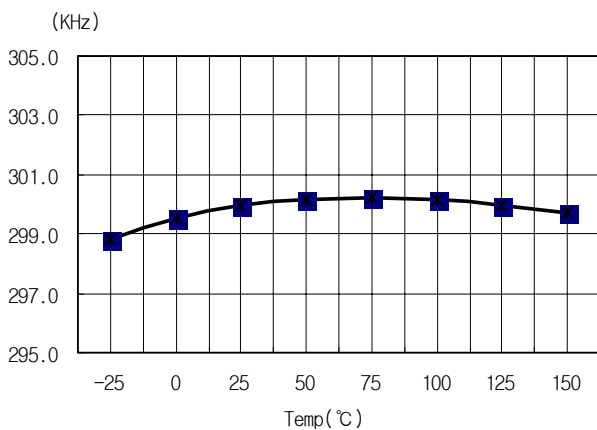

Figure 5. Initial Frequency vs. Temp.

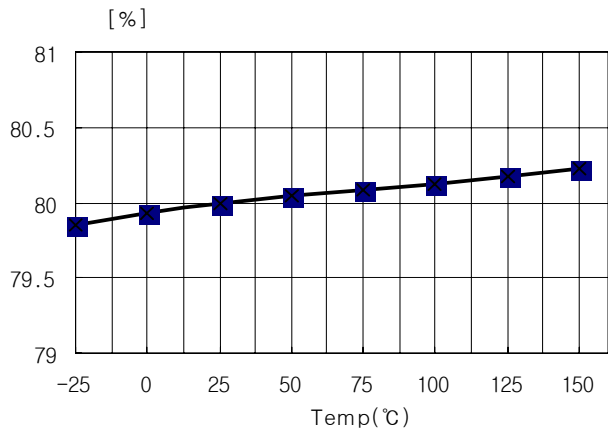
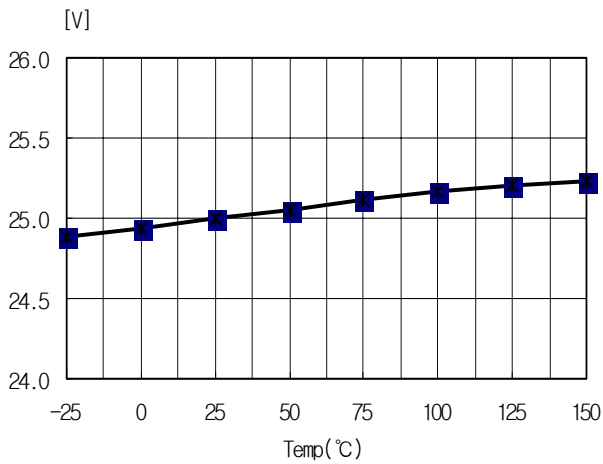

Figure 6. Maximum Duty vs. Temp.

**Typical Performance Characteristics** (Continued)

(These Characteristic Graphs are Normalized at Ta= 25°C)



**Figure 7. Over Voltage Protection vs. Temp.**

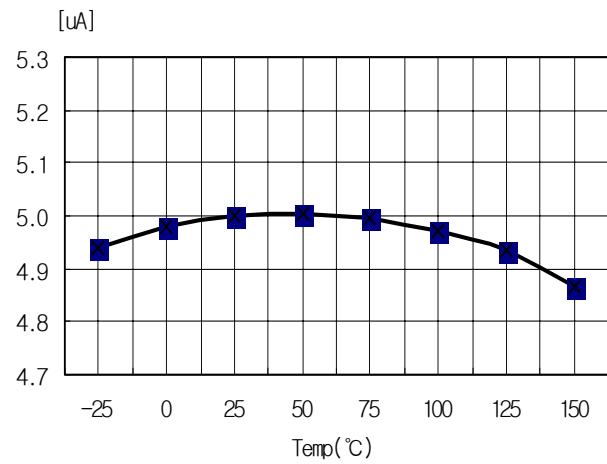

**Figure 8. Shutdown Delay Current vs. Temp.**

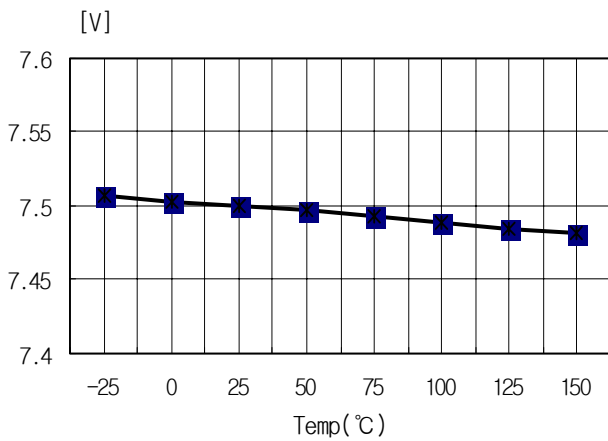

**Figure 9. Shutdown Feedback Voltage vs. Temp.**

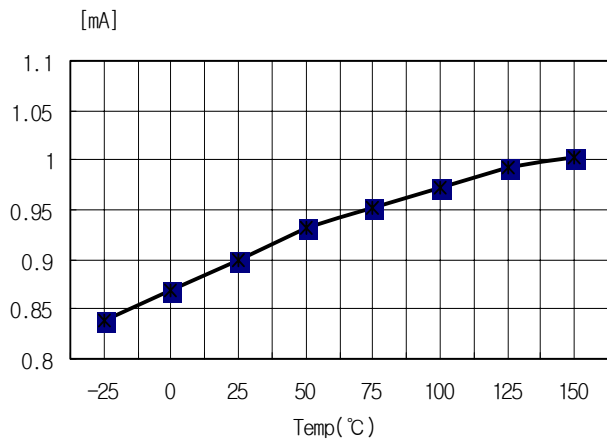

**Figure 10. Feedback Source Current vs. Temp.**

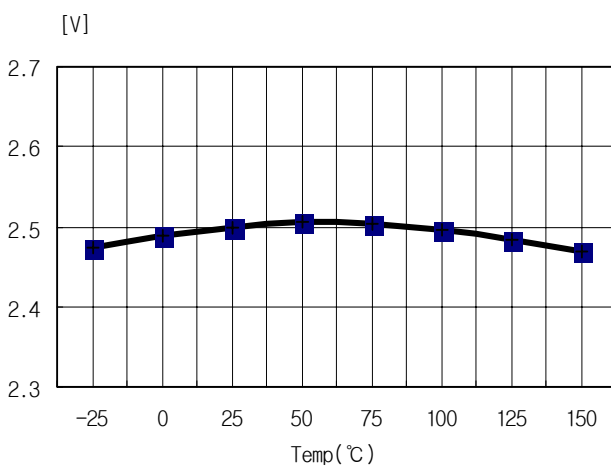

**Figure 11. Line UVLO threshold voltage vs. Temp.**

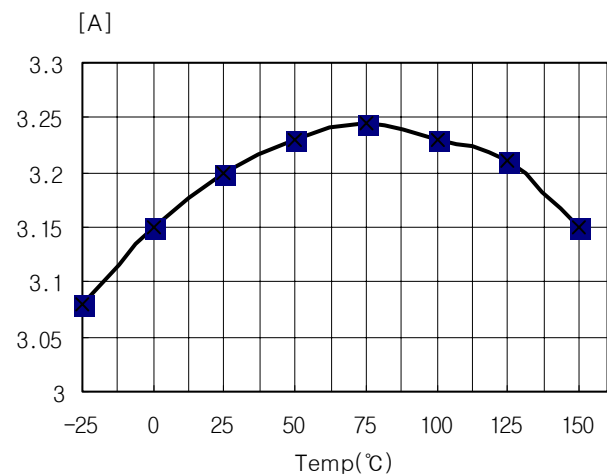

**Figure 12. Peak Current Limit vs. Temp.**

## Functional Description

**1. Startup :** To guarantee stable operation of the control IC, Vcc has under voltage lockout (UVLO) with 6V hysteresis. Figure 1 shows the relation between the supply current (Icc) and the supply voltage (Vcc). Before Vcc reaches 15V, the start-up current is 60μA, which is usually provided by the DC link through start-up resistor. When Vcc reaches 15V, the control IC begins operation and the operating current increases to 10mA as shown. Once the control IC starts operation, it continues its normal operation unless Vcc goes below the stop voltage of 9V.

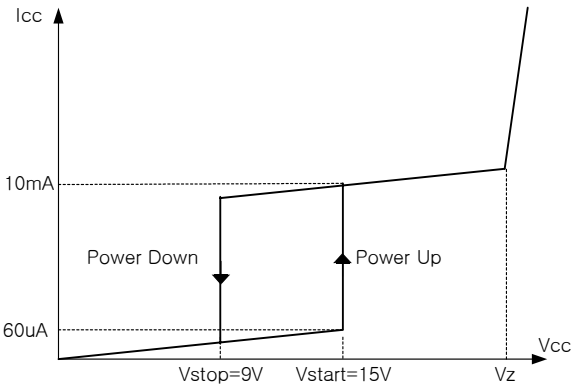

Figure 1. Relation between supply current and voltage

**2. Feedback Control :** The FS6X1220R employs current mode control. The voltage of the feedback pin is compared with the current sense voltage for pulse width modulation (PWM). Figure 2 illustrates the simplified PWM block. The feedback voltage determines the peak drain current of the SenseFET. Usually opto-coupler along with TL431 are used to implement feedback network. The collector of the opto-coupler transistor is connected to feedback pin and the emitter is connected to the ground pin. When the voltage of the reference pin of TL431 exceeds the internal reference voltage of 2.5V, the opto-coupler diode current increases, pulling down the feedback voltage.

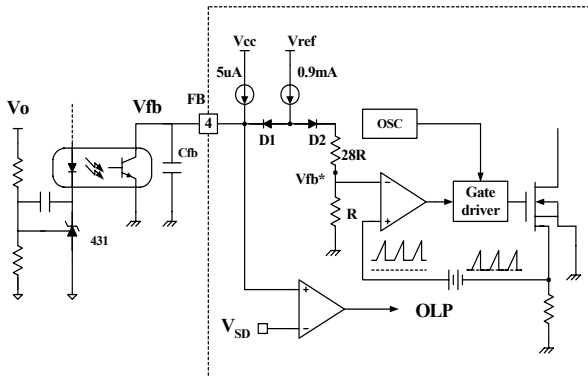

Figure 2. Pulse width modulation (PWM) circuit

**3. Protection Circuit :** Besides pulse-by-pulse current limit, the FS6X1220R has 3 self protection functions; over load protection (OLP), over voltage protection (OVP) and thermal shutdown (TSD). Because these protection circuits are fully integrated into the IC without external components, the reliability can be improved. In the event of these fault conditions, FS6X1220R enters into auto-restart operation. Once the fault condition occurs, switching operation is terminated and MOSFET remains off, which causes Vcc to be reduced. When Vcc reaches 9V, the protection is reset and the supply current reduces to 60uA. Then, Vcc begin to increase with the current provided through the start-up resistor. When Vcc reaches 15V, FS6X1220R resumes its normal operation if the fault condition is removed. In this manner, the auto-restart alternately enables and disables the switching of the power MOSFET until the fault condition is eliminated as illustrated in figure 3.

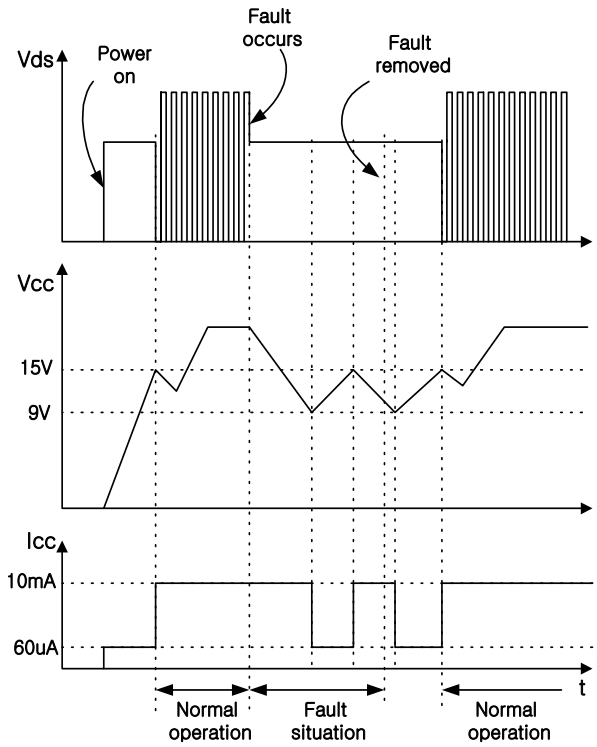

Figure 3. Auto restart operation after protection

**3.1 Pulse-by-pulse current limit :** As shown in figure 2, the drain current of the power MOSFET is limited by the inverting input of PWM comparator ( $V_{fb}^*$ ). Assuming that the 0.9mA current source flows only through the internal resistor ( $28R + R = 2.9k$ ), the cathode voltage of diode D2 is about 2.6V. Since D1 is blocked when the feedback voltage ( $V_{fb}$ ) exceeds 2.6V, the maximum voltage of the cathode of D2 is 2.6V. Therefore, the maximum value of  $V_{fb}^*$  is about 0.1V, which limits the peak value of the power MOSFET drain current.



**3.2 Over Load Protection (OLP) :** Overload means that the load current exceeds a pre-set level due to an abnormal situation. In this situation, protection circuit should be activated in order to protect the SMPS. However, even when the SMPS is in the normal operation, the over load protection circuit can be activated during the load transition. In order to avoid this undesired operation, the over load protection circuit is designed to be activated after a specified period to determine whether it is a transient situation or an overload situation. Because of the pulse-by-pulse current limit capability, the maximum peak current through the SMPS is limited, and therefore the maximum input power is restricted with a given input voltage. If the output consumes beyond this maximum power, the output voltage (Vo) decreases below the set voltage. This reduces the current through the opto-coupler diode, which also reduces opto-coupler transistor current increasing Vfb. If Vfb exceeds 2.6V, D1 is blocked and the 5μA current source starts to charge Cfb slowly compared to when the 0.9mA current source charges Cfb. In this condition, Vfb continues increasing until it reaches 7.5V, and the switching operation is terminated at that time as shown in figure 4. The delay time for shutdown is the time required to charge Cfb from 2.6V to 7.5V with 5μA. When Cfb is 10nF (103), T12 is approximately 9.8ms and when Cfb is 0.1μF (104), T12 is approximately 98ms. These values are enough to prevent SMPS from being shut down during transient situations.

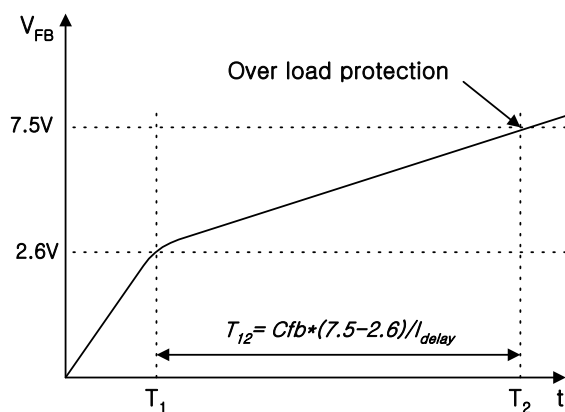

Figure 4. Over load protection

**3.3 Over voltage Protection (OVP) :** In case of malfunction in the secondary side feedback circuit, or feedback loop open caused by a defect of solder, the current through the opto-coupler transistor becomes almost zero. Then, Vfb climbs up in a similar manner to the over load situation, forcing the preset maximum current to be supplied to the secondary side until the over load protection is activated. Because energy more than required is provided to the output, the output voltage may exceed the rated voltage before the over load protection is activated, resulting in the breakdown of the devices in the secondary side. In order to prevent this situation, an over voltage protection (OVP) circuit is employed. In general, Vcc is proportional to the output

voltage and FS6X1220R uses Vcc instead of directly monitoring the output voltage. If VCC exceeds 25V, OVP circuit is activated resulting in termination of switching. In order to avoid undesired activation of OVP during normal operation, Vcc should be properly designed to be below 25V.

**3.4 Thermal Shutdown (TSD) :** The thermal shutdown circuitry senses the junction temperature. The threshold is set at 160°C. When the junction temperature rises above this threshold (160°C) the power MOSFET is disabled.

**4. The Line UVLO and Sleep Mode**

According to the voltage of Line Sense pin, three operation modes are defined; Normal operation mode, Line under voltage lock out mode and Sleep mode as shown in figure 5. When the voltage of this pin is over 2.55V, FS6X1220R operates in normal mode. When the voltage of this pin is smaller than 2.55V, it goes into line under voltage lock out mode terminating switching operation. When the voltage of this pin is smaller than 1.8V, it enters into sleep mode. During sleep mode, reference voltage generation circuit including shunt regulator is disabled and only 300μA operation current is required.

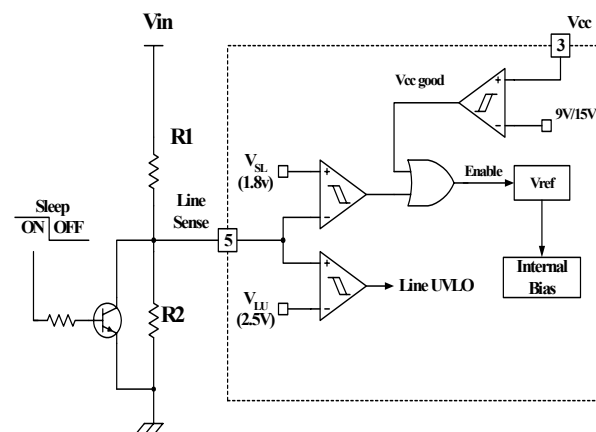
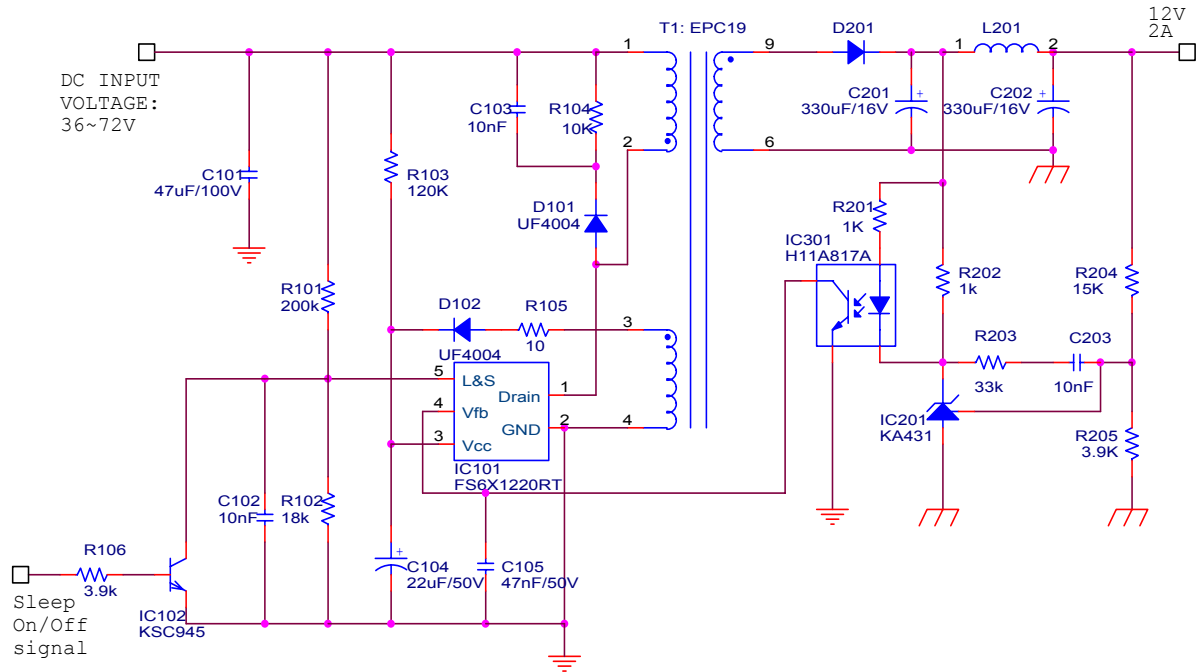

Figure 5. Line Sense block

# Typical Application Circuit

## 1. Application circuit for DC-DC converter (Flyback)



## 2. Transformer Schematic Diagram

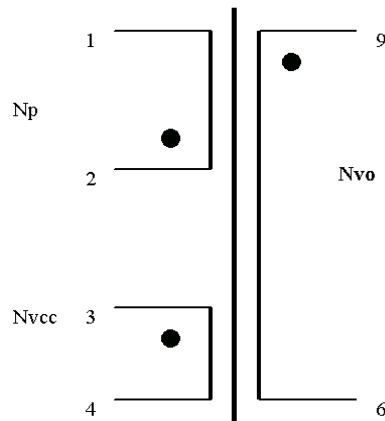

### 3.Winding Specification

Name	Pin (s→f)	Wire	Turns	Winding Method
Np <sup>1</sup>	2 → 1	0.3 <sup>φ</sup> × 1	20	Solenoid Winding
Insulation: Polyester Tape t = 0.050mm, 2Layers				
Nvo	9 → 6	0.3 <sup>φ</sup> × 2	12	Solenoid Winding
Insulation: Polyester Tape t = 0.050mm, 2Layers				
Nvcc	3 → 4	0.2 <sup>φ</sup> × 1	18	Solenoid Winding
Insulation: Polyester Tape t = 0.050mm, 2Layers				
Np <sup>2</sup>	2 → 1	0.3 <sup>φ</sup> × 1	20	Solenoid Winding
Outer Insulation: Polyester Tape t = 0.050mm, 2Layers				

### 4.Electrical Characteristics

	Pin	Specification	Remarks
Inductance	1 - 2	28uH ± 10%	300kHz, 1V
Leakage Inductance	1 - 2	2uH Max	2 <sup>nd</sup> all short

### 5. Core & Bobbin

Core : EPC 19

Bobbin : EPC 19

Ae(mm<sup>2</sup>) : 22.7

### 6.Demo Circuit Part List

Part	Value	Note	Part	Value	Note
<b>Resistor</b>			C201	330uF/16V	Electrolytic Capacitor
R101	200K, 1/4W	-	C202	330uF/16V	Electrolytic Capacitor
R102	18K, 1/4W	-	C203	10nF/50V	Ceramic Capacitor
R103	120K, 1/4W	-	-	-	-
R104	10K, 1/4W	-	-	-	-
R105	10, 1/4W	-	<b>Diode</b>		
R106	3.9K, 1/4W	-	D101	UF4004	-
R201	1K, 1/4W	-	D102	UF4004	-
R202	1K, 1/4W	-	D201	MBRF10100	-
R203	33K, 1/4W	-	-	-	-
R204	15K, 1/4W	-	<b>IC</b>		
R205	3.9K, 1/4W	-	IC101	FS6X1220RT	(3.2A, 200V)
<b>Capacitor</b>			IC102	KSC945	npn transistor
C101	47uF, 100V	Electrolytic Capacitor	IC201	KA431(LM431)	Voltage reference
C102	10nF, 50V	Ceramic Capacitor	PC	H11A817A	Photo coupler / QT
C103	10nF, 200V	Ceramic Capacitor	-	-	-
C104	22uF, 50V	Electrolytic Capacitor	-	-	-
C105	47nF, 50V	Ceramic Capacitor	-	-	-

Package Dimensions

TO-220F-5L(Forming)

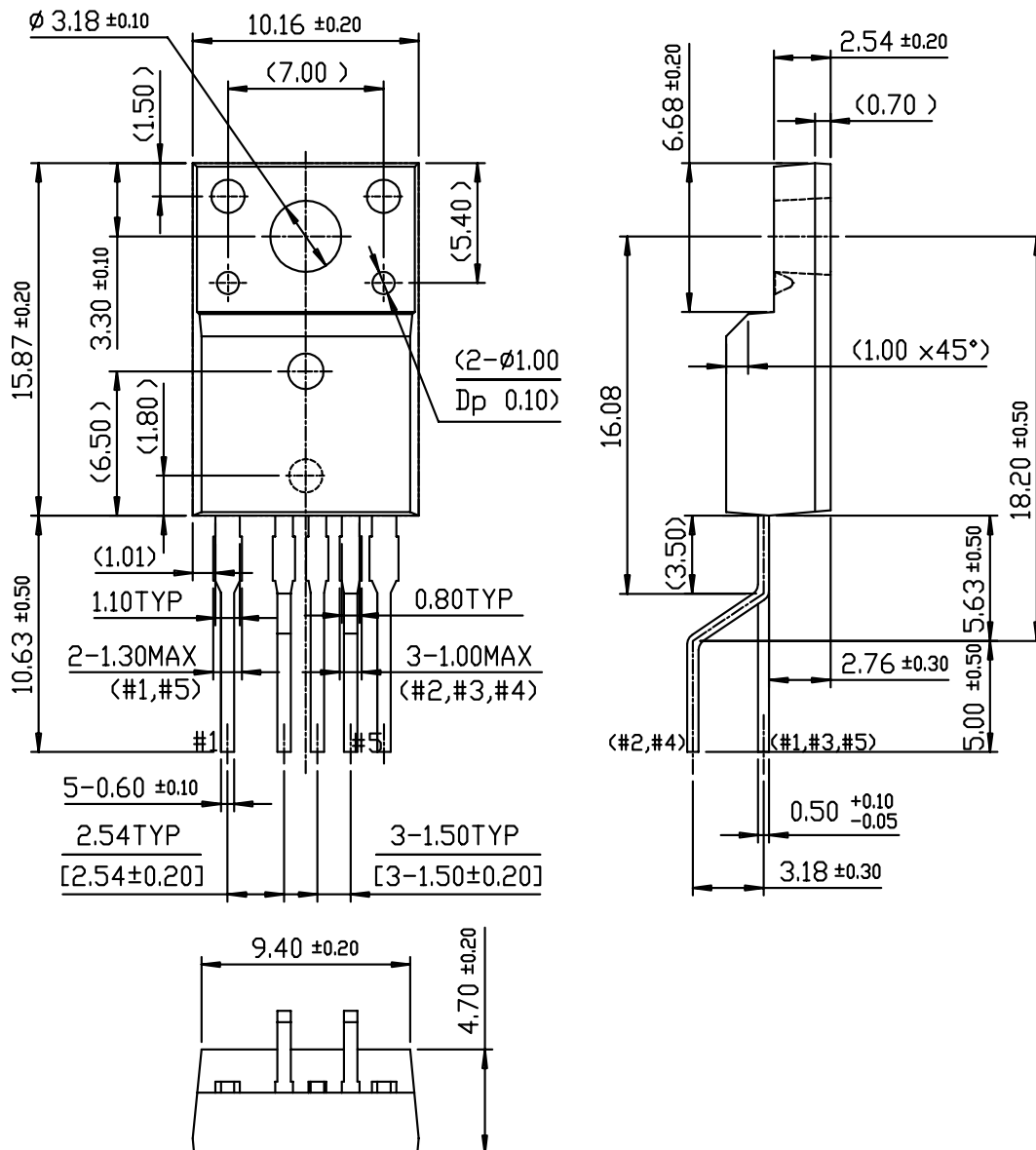

Package Dimensions (Continued)

D2-PAK-5L

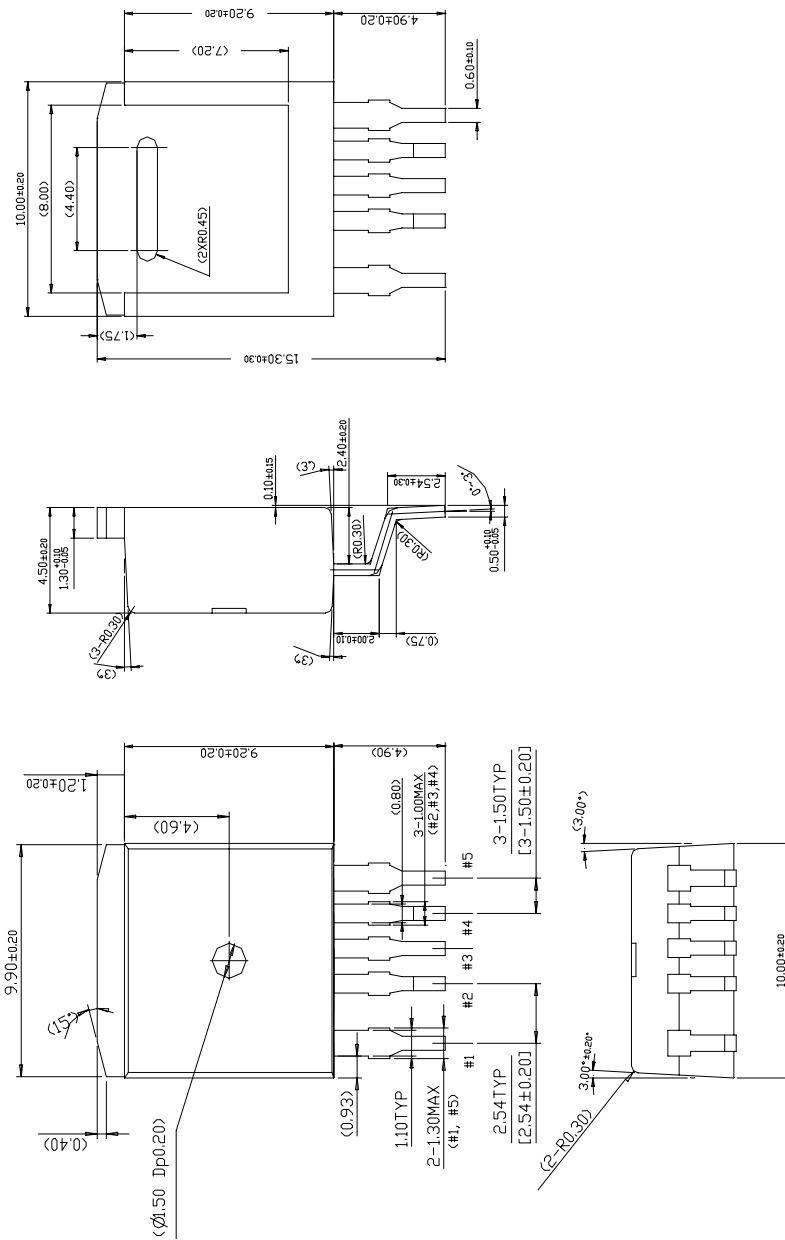

## Ordering Information

Product Number	Package	Marking Code	BVdss	Rds(on) <sup>Max.</sup>
FS6X1220RTYDTU	TO-220F-5L(Forming)	6X1220R	200V	0.30Ω
FS6X1220RD	D2-PAK-5L			

YDTU : Forming Type

### DISCLAIMER

FAIRCHILD SEMICONDUCTOR RESERVES THE RIGHT TO MAKE CHANGES WITHOUT FURTHER NOTICE TO ANY PRODUCTS HEREIN TO IMPROVE RELIABILITY, FUNCTION OR DESIGN. FAIRCHILD DOES NOT ASSUME ANY LIABILITY ARISING OUT OF THE APPLICATION OR USE OF ANY PRODUCT OR CIRCUIT DESCRIBED HEREIN; NEITHER DOES IT CONVEY ANY LICENSE UNDER ITS PATENT RIGHTS, NOR THE RIGHTS OF OTHERS.

### LIFE SUPPORT POLICY

FAIRCHILD'S PRODUCTS ARE NOT AUTHORIZED FOR USE AS CRITICAL COMPONENTS IN LIFE SUPPORT DEVICES OR SYSTEMS WITHOUT THE EXPRESS WRITTEN APPROVAL OF THE PRESIDENT OF FAIRCHILD SEMICONDUCTOR CORPORATION. As used herein:

1. Life support devices or systems are devices or systems which, (a) are intended for surgical implant into the body, or (b) support or sustain life, and (c) whose failure to perform when properly used in accordance with instructions for use provided in the labeling, can be reasonably expected to result in a significant injury of the user.
2. A critical component in any component of a life support device or system whose failure to perform can be reasonably expected to cause the failure of the life support device or system, or to affect its safety or effectiveness.