



# Optical Encoders

## SERIES 62HR 1/2" Package, Redundant Circuitry High Torque

### FEATURES

- Redundant Circuitry
- 1 Million Rotational Cycles
- Compatible with CMOS, TTL and HCMOS Logic
- Optional Integral Pushbutton
- Available in 8, 12, 16 Detent Positions
- Choices of Cable Length and Terminations
- Ideal for Critical Applications

### APPLICATIONS

- Cockpit Controls
- Medical Equipment
- Avionics



### DIMENSIONS in inches (and millimeters)

SERIES 62HR WITH .050 CENTER RIBBON CABLE

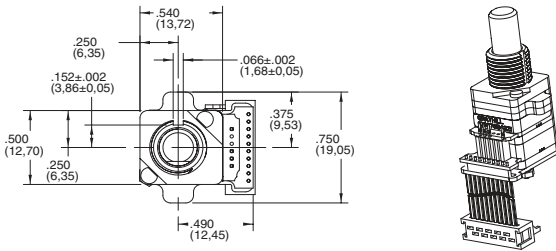

SERIES 62HR WITH .050 CENTER TERMINAL PINS

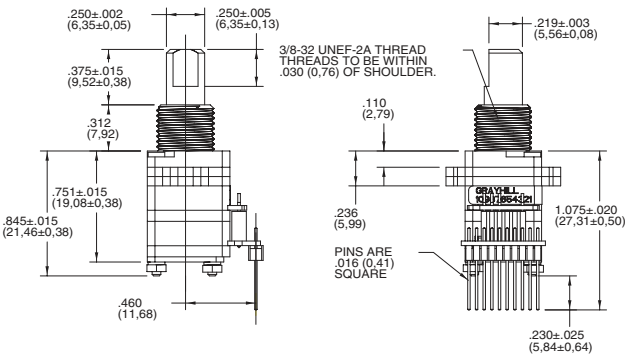
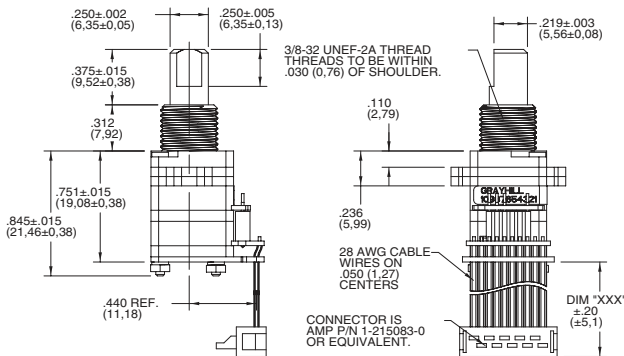
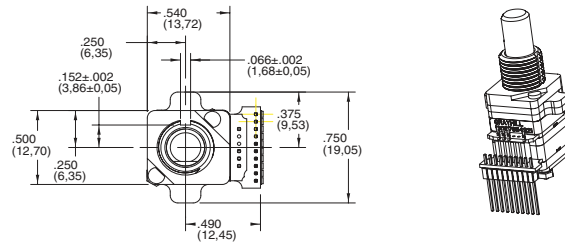

### Suggested Mounting Panel Cutout

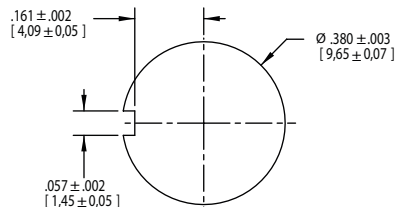

UNLESS OTHERWISE SPECIFIED, STANDARD TOLERANCE IS ±.010 (0.25).

**CIRCUITRY, TRUTH TABLE, AND WAVEFORM** Standard Quadrature 2-Bit Code

**Switch Schematic**

\* External pull-up resistors required for operation (2.2 kΩ).

**Truth Table (CW Rotation)**

POSITION	DECK A		DECK B	
	OUTPUT 'A'	OUTPUT 'B'	OUTPUT 'A'	OUTPUT 'B'
1				
2	●		●	
3	●	●	●	●
4		●		●

● INDICATES LOGIC HIGH. BLANK INDICATES LOGIC LOW. CODE REPEATS EVERY 4 POSITIONS

**Wave Form (CW Rotation)**

**SPECIFICATIONS**

**Pushbutton Switch Ratings**

- Rating:** at 5 Vdc, 10 mA, resistive
- Contact Resistance:** less than 10 ohms (TTL or CMOS compatible)
- Pushbutton Life:** 3 million actuations minimum
- Voltage Breakdown:** 250 Vac between mutually insulated parts
- Contact Bounce:** less than 4 mS at make and less than 10 mS at break
- Actuation Force:** 1100 ±300g
- Shaft Travel:** .025+/- .010 inch

**Encoder Ratings**

- Coding:** 2-bit quadrature coded output
- Operating Voltage:** 5.0 ±.25 Vdc
- Supply Current:** 30 mA maximum @5.0 Vdc per deck
- Logic Output Characteristics:**
- Logic High:** 3.0 Vdc minimum
- Logic Low:** 1.0 Vdc maximum
- Mechanical Life:** 1,000,000 cycles minimum (One cycle is a rotation through all positions and a full return)
- Minimum Sink Current:** 2.0 mA for 5 Vdc
- Power Consumption:** 150mW maximum
- Output:** open collector phototransistor

- Logic Rise and Fall:** less than 30 mS maximum
- Operating Torque:** 5.0 in-oz +/- 1.5 in-oz initial
- Shaft Push Out Force:** 45 lbs minimum
- Mounting Torque:** 15 in-lbs maximum
- Terminal Strength:** 15 lbs cable pull-out force minimum
- Operating Speed:** 100 RPM maximum

**Environmental Ratings**

- Operating Temperature Range:** -40°C to 85°C
- Storage Temperature Range:** -55°C to 100°C
- Vibration Resistance:** Harmonic motion with amplitude of 15G, within a varied 10 to 2000 Hz frequency for 12 hours
- Mechanical Shock:** Test 1: 100G, 6 mS, half sine, 12.3 ft/s; Test 2: 100G, 6 mS, sawtooth, 9.7 ft/s
- Relative Humidity:** 90–95% at 40°C for 96 hours

**Materials and Finishes**

- Code Housing:** Reinforced thermoplastic
- Shaft:** Stainless steel

- Bushing:** Zinc casting
- Shaft Retaining Ring:** Stainless steel
- Detent Spring:** High carbon steel
- Detent Ball:** Stainless steel
- Detent Section:** Hiloy 610
- Printed Circuit Boards:** NEMA grade FR-4 gold over nickel or palladium
- Terminals:** Brass, tin-plated
- Mounting Hardware:** One brass, nickel-plated nut and zinc-plated spring steel with clear trivalent chromate finish lockwasher supplied with each switch. (Nut is 0.094 inches thick by 0.433 inches across flats)
- Rotor:** Thermoplastic
- Pushbutton Dome:** Stainless steel
- Phototransistor:** Planar Silicon NPN
- Infrared Emitter:** Gallium aluminum arsenide
- Flex Cable:** 28AWG, stranded/top coated wire, PVC coated on .050" centers (cabled version)
- Header Pins:** Brass, tin-plated
- Spacer:** Hiloy 610
- Shim:** Stainless Steel
- Backplate/Strain Relief:** Stainless steel

**ORDERING INFORMATION**

**62HRXX-XX-020X**

**Series**

**Style:** HR = High Torque, Redundant

**Angle of Throw:** 45 = 45° or 8 positions, 30 = 30° or 12 positions, 22 = 22.5° or 16 positions

**Termination:** S = stripped cable, C = connector, P = pins

**Cable Length:** 020 = 2.0 inches. Cable is terminated with Amp Connector P/N 1-215083-0. See Amp Mateability Guide for mating connector details.

\*Eliminate cable length if ordering pins. (Ex: 62HR22-H9-P)

**Pushbutton Option:** 0 = w/o pushbutton, 9 = 1100g pushbutton

**Rotational Torque:** H = High Torque

Optical and Mechanical Encoders