

# 183704106x

850nm 300m SFP+ Transceiver



## Features

- ☑ 850nm VCSEL laser
- ☑ Transmission distance up to 300m on OM3 MM fiber
- ☑ Low power consumption
- ☑ Wide Case Operating Temperature Range
- ☑ Compliant with SFP+ Electrical MSA SFF-8431
- ☑ Compliant with SFP+ Mechanical MSA SFF-8432
- ☑ Digital Diagnostics Monitoring (DDM) through Serial Interface comply with SFF-8472, Rev. 10.4
- ☑ Compliant with product safety standards



## Description

The 183704106x is an enhanced small form factor pluggable (SFP+) fiber optic transceiver with digital diagnostics monitoring functionality (DDM). Supporting Ethernet and Fiber Channel standards makes it ideally suited for 10Gbps data-com and storage area network applications. DDM functionality (alarm and warning features) is integrated into the design via an I<sup>2</sup>C serial interface per the Multi-Source Agreement (MSA) SFF-8472, Rev. 10.4.

The transceiver supports data rates ranging from 11.3Gbps down to 2Gbps. It provides an excellent solution for transmission at 850nm over up to 300m 2000MHz-km multimode fiber. The sub-watt power consumption and excellent EMI performance allow system design with high port density. The product is RoHS compliant and is designed and tested in accordance with industry safety standards. The transceiver is Class 1 Laser product per U.S. FDA/CDRH and international IEC-60825 standards.

The 183704106x transceiver connects to standard 20-pad SFP+ connectors for hot plug capability. This allows the system designer to make configuration changes or maintenance by simply plugging in different transceivers without removing the power supply from the host system. The transmitter and receiver DATA interfaces are internally AC-coupled. LV-TTL Transmitter Disable control input and Loss of Signal (LOS) output interfaces are also provided.

The transceiver has bail-type latch, which offers an easy and convenient way to release the modules. The latch is compliant with the SFP MSA.

The transceiver operates from a single +3.3V power supply over an operating case temperature range of -5°C to +70°C (Commercial), or -5°C to +85°C (Extended). The housing is made of metal for EMI immunity.

## Absolute Maximum Ratings

Parameters	Symbol	Min	Max	Units
Storage Temperature Range	$T_{ST}$	-40	+85	°C
Operating Temperature Range <sup>1</sup>	Commercial	-5	+70	°C
	Extended	-5	+85	
Operating Relative Humidity <sup>2</sup>	$RH$	0	85	%
Supply Voltage Range	$V_{CC}$	-0.5	+3.6	V

<sup>1</sup> Measured on top side of SFP+ module at the front center vent hole of the cage  
<sup>2</sup> Non condensing

## Transmitter Performance Characteristics (Over Operating Case Temperature, $V_{CC}=3.13$ to $3.47V$ )

Parameter	Symbol	Min	Typ	Max	Units
Data Rate	$B$	2.0	-	11.3	Gb/s
Center Wavelength	$\lambda_C$	840	850	860	nm
Spectral Width	$\Delta\lambda_{rms}$	-	-	0.45	nm
Average Launch Power <sup>1</sup>	$P_{avg}$	-5	-	-1	dBm
Launch Power in OMA <sup>1</sup>	$P_{OMA}$	-	-1.5	-	dBm
Extinction Ratio	$ER$	3	-	-	dB
Relative Intensity Noise	$RIN_{12OMA}$	-	-	-128	dB/Hz
Average Launch Power of OFF Transmitter	$P_{off}$	-	-	-30	dBm
Transmitter and Dispersion Penalty @ 10.3125Gb/s	$TDP$	-	-	3.9	dB

<sup>1</sup> Launch power figures are informative only, per IEEE 802.3ae.

## Receiver Performance Characteristics (Over Operating Case Temperature, $V_{CC}=3.13$ to $3.47V$ )

Parameter	Symbol	Min	Typ	Max	Units	
Data Rate	$B$	2.0	-	11.3	Gb/s	
Wavelength of Operation	$\lambda$	840	-	860	nm	
Receiver Sensitivity	$P_{avg}$ @ 10.3125Gb/s <sup>1</sup>	-	-	-9.9	dBm	
	OMA @ 10.3125Gb/s <sup>1</sup>	-	-	-11.1		
Stressed Receiver Sensitivity in OMA (@10.3125Gb/s) <sup>2</sup>	-	-	-	-7.5	dBm	
Maximum Input Power ( $10^{-12}$ BER)	$P_{MAX}$	+0.5	-	-	dBm	
LOS Hysteresis	-	0.5	-	-	dB	
LOS Thresholds	Increasing Light Input	$P_{los+}$	-	-	-11	dBm
	Decreasing Light Input	$P_{los-}$	-30	-	-	

<sup>1</sup> Specified with BER  $<1 \times 10^{-12}$  and PRBS 2<sup>31</sup>-1.  
<sup>2</sup> Compliant with IEEE 802.3ae

Note: The specified characteristics are met within the recommended range of operation. Unless otherwise noted typical data are quoted at nominal voltage and +25°C ambient temperature.

### Laser Safety:

All transceivers are Class 1 Laser products per FDA/CDRH and IEC-60825 standards. They must be operated under specified operating conditions.



**Molex, LLC.**

This product complies with  
 21 CFR 1040.10 and 1040.11  
**Meets Class 1 Laser Safety Requirements**

## Transmitter Electrical Characteristics (Over Operating Case Temperature, $V_{CC}=3.13$ to $3.47V$ )

Parameter	Symbol	Min	Typ	Max	Units
Differential Input Impedance	$Z_d$	-	100	-	$\Omega$
Differential Input Voltage Swing	$V_{PP-DIFF}$	180	-	700	mV
Input High Voltage (TX Disable) <sup>1</sup>	$V_{IH}$	2.0	-	$V_{CC}$	V
Input LOW Voltage (TX Disable) <sup>1</sup>	$V_{IL}$	0	-	0.8	V
Output High Voltage (TX Fault) <sup>2</sup>	$VOH$	2.0	-	$V_{CC}+0.3$	V
Output LOW Voltage (TX Fault) <sup>2</sup>	$VOL$	0	-	0.8	V

<sup>1</sup>There is an internal 4.7 k $\Omega$  to 10 k $\Omega$  pull-up resistor to  $V_{CC}$   
<sup>2</sup>Open collector compatible, 4.7 k $\Omega$  to 10 k $\Omega$  pull-up resistor to  $V_{CC}$  (Host Supply Voltage)

## Receiver Electrical Characteristics (Over Operating Case Temperature, $V_{CC}=3.13$ to $3.47V$ )

Parameter	Symbol	Min	Typ	Max	Units
Differential Output Impedance	$Z_d$	-	100	-	$\Omega$
Differential Output Swing	$V_{PP-DIFF}$	300	450	850	mV
Output Rise and Fall time 20% to 80%	$t_{RH}, t_{FH}$	24	-	-	ps
Output HIGH Voltage (LOS) <sup>1</sup>	$VOH$	$V_{CC}-1.3$	-	$V_{CC}+0.3$	V
Output Low Voltage (LOS) <sup>1</sup>	$VOL$	0	-	0.8	V

<sup>1</sup>Open collector compatible, 4.7 k $\Omega$  to 10k $\Omega$  pull-up resistor to  $V_{CC}$  (Host Supply Voltage)

## Electrical Power Supply Characteristics (Over Operating Case Temperature, $V_{CC}=3.13$ to $3.47V$ )

Parameter	Symbol	Min	Typ	Max	Units
Power Supply Voltage	$V_{CC}$	3.13	3.30	3.47	V
DC Common Mode Voltage	$V_{CM}$	0	-	3.6	V
Supply Current	$I_{VCC}$	-	-	280	mA
Power Consumption	$P_W$	-	0.6	1.0	W

Note: The specified characteristics are met within the recommended range of operation. Unless otherwise noted typical data are quoted at nominal voltage and +25°C ambient temperature.

## Connector Pin-out

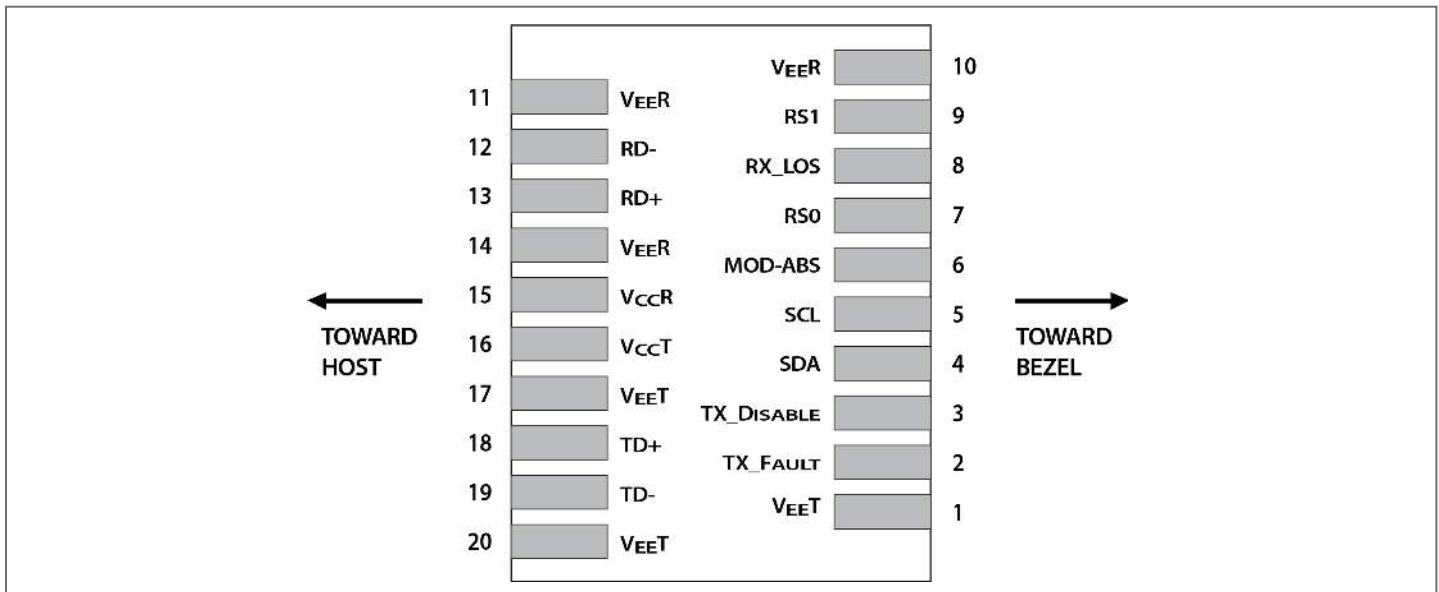

## Electrical Pin Definition

PIN	Logic	Symbol	Name / Description
1	-	<i>VeeT</i>	Module Transmitter Ground
2	LVTTL-O	<i>TX_Fault</i>	Module Transmitter Fault
3	LVTTL-I	<i>TX_Disable</i>	Transmitter Disable; Turns off transmitter laser output
4	LVTTL-I/O	<i>SDA</i>	2-Wire Serial Interface Data Line
5	LVTTL-I/O	<i>SCL</i>	2-Wire Serial Interface Clock
6	-	<i>MOD-ABS</i>	Module Definition, Grounded in the module
7	LVTTL-I	<i>RS0</i>	No function implemented
8	LVTTL-O	<i>RX_LOS</i>	Receiver Loss of Signal Indication
9	LVTTL-I	<i>RS1</i>	No function implemented
10	-	<i>VeeR</i>	Module Receiver Ground
11	-	<i>VeeR</i>	Module Receiver Ground
12	CML-O	<i>RD-</i>	Receiver Inverted Data Output
13	CML-O	<i>RD+</i>	Receiver Non-Inverted Data Output
14	-	<i>VeeR</i>	Module Receiver Ground
15	-	<i>VccR</i>	Module Receiver 3.3V Supply
16	-	<i>VccT</i>	Module Transmitter 3.3V Supply
17	-	<i>VeeT</i>	Module Transmitter Ground
18	CML-I	<i>TD+</i>	Transmitter Non-Inverted Data Input
19	CML-I	<i>TD-</i>	Transmitter Inverted Data Input
20	-	<i>VeeT</i>	Module Transmitter Ground

## Application Notes

**Electrical interface:** All signal interfaces are compliant with the SFP+ MSA specification. The high speed DATA interface is differential AC-coupled internally and can be directly connected to a 3.3V SERDES IC. All low speed control and sense output signals are open collector TTL compatible and should be pulled up with a 4.7kΩ - 10kΩ resistor on the host board.

**Loss of Signal (LOS):** The Loss of Signal circuit monitors the level of the incoming optical signal and generates logic HIGH when an insufficient photocurrent is produced.

**TX Fault:** The output indicates LOW when the transmitter is operating normally and HIGH with a laser fault including laser end-of-life. TX Fault is an open collector/drain output and should be pulled up with a 4.7kΩ - 10kΩ resistor on the host board.

**TX Disable:** When the TX Disable pin is at logic HIGH, the transmitter optical output is disabled. The laser is also disabled if this line is left floating, as it is pulled high inside the transceiver.

**Serial Identification and Monitoring:** The module definition of SFP is indicated by the MOD\_ABS pin and the 2-wire serial

interface. Upon power up, the 2-wire interface appears as NC (no connection), and MOD\_ABS is TTL LOW. When the host system detects this condition, it activates the serial protocol (standard two-wire I<sup>2</sup>C serial interface) and generates the serial clock signal (SCL). The positive edge clocks data into the EEPROM segments of the device that are not write protected, and the negative edge clocks data from the device. The serial data signal (SDA) is for serial data transfer. The host uses SDA in conjunction with SCL to mark the start and end of serial protocol activation. The supported monitoring functions are temperature, voltage, bias current, transmitter power, average receiver signal, all alarms and warnings, and software monitoring of TX Fault/LOS. The device is internally calibrated.

The data transfer protocol and the details of the mandatory and vendor specific data structures are defined in the SFP MSA, and SFF-8472, Rev. 10.4

**Power supply and grounding:** The power supply line should be well-filtered. All power supply bypass capacitors should be as close to the transceiver module as possible.

## Interfacing the Transceivers

Communication is via a serial 2-wire serial interface. As described in the document SFF-8472 (REV. 10.4) there are two distinct address spaces:

Base Address A0(hex)	
Byte Address	Content
0 – 95	Serial Transceiver ID as defined in SFP MSA
96 – 127	OPLINK Specific
128 – 255	Reserved

Base Address A2(hex)	
Byte Address	Content
0 - 55	Alarm & Warnings thresholds & limits
56 - 95	External calibration constants (not used)
96 – 119	Values from real time diagnostic monitoring
120 – 127	Not used
128 – 247	Customer specific, writable area
248 - 255	Not used

## Application Schematics

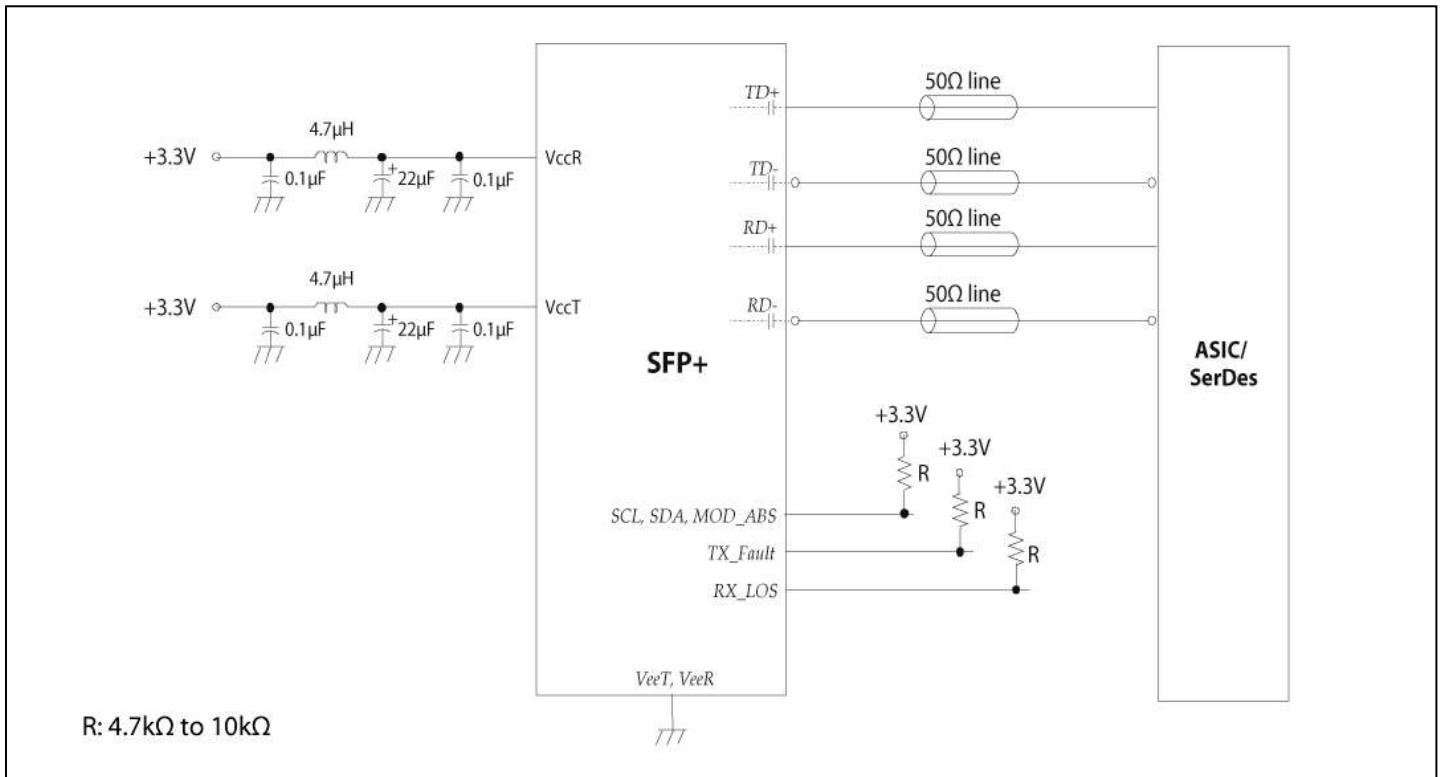

## ESD & Electromagnetic Compatibility

Requirements	Standard	Status
Electro Static Discharge to the Electrical Pins (ESD)	EIA/JESD22-A114-B MIL-STD 883C Method 3015.7	Exceeds requirements Class 1B (>1000V)
Immunity to ESD (housing, receptacle)	IEC 61000-4-2	Exceeds requirements Discharges ranging from 2kV to 15kV without damages to the transceiver
Electromagnetic Emission (EMI)	FCC Part 15, Class B EN 55022 Class B CISPR 22	Exceeds requirements Class B

# 183704106x

850nm 300m SFP+ Transceiver



## Module Outline

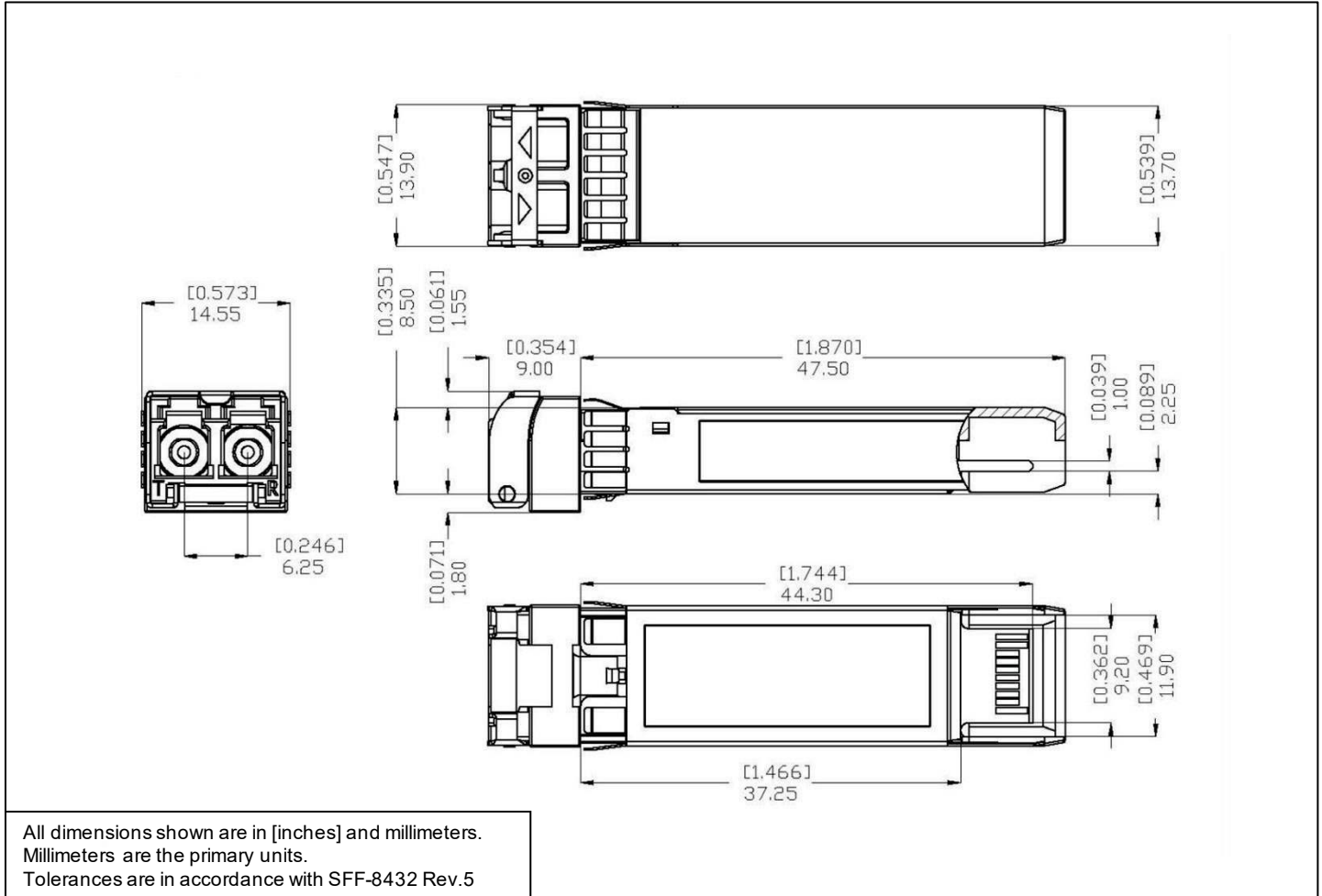

## Ordering Information

Molex Part Number	Model No.	Operating Temperature	Nominal Wavelength (nm)	Distance (m)	Latch Color
1837041061	TPP4XGDS0C000E2G	-5°C to +70°C	850	300	BEIGE
1837041060	TPP4XGDS0E000E2G	-5°C to +85°C	850	300	BEIGE

Molex, LLC. reserves the right to make changes in equipment design or specifications without notice. Information supplied by Molex, LLC. is believed to be accurate and reliable. However, no responsibility is assumed by Molex, LLC. for its use nor for any infringements of third parties, which may result from its use. No license is granted by implication or otherwise under any patent right of Molex, LLC.