

PART NAME: HANDLE SCALE: 1:1 DATE: 9/12/85 DR. BY HD

THIS DRAWING IS THE PROPERTY OF DAVIES MOLDING COMPANY, IS SUBMITTED SOLELY AS A DESIGN OR ENGINEERING PROJECT. WE ACCEPT NO RESPONSIBILITY WHATSOEVER FOR THE PRACTICAL APPLICATION OF THE PIECES MADE TO THIS DESIGN.



DESIGNERS & MANUFACTURERS OF KNOBS, HANDLES, CASES & CUSTOM PLASTIC COMPONENTS

P/N	3094-J
M NO.	27
CAVITY	3094
CORE	3094
CORE PLUG	3094-Q
EJECT. PIN	3094
INSERT	10442

TOP SURFACE OF KNOB AND OUTER SURFACES UP TO PARTING LINE ARE TEXTURED (RE-6320)

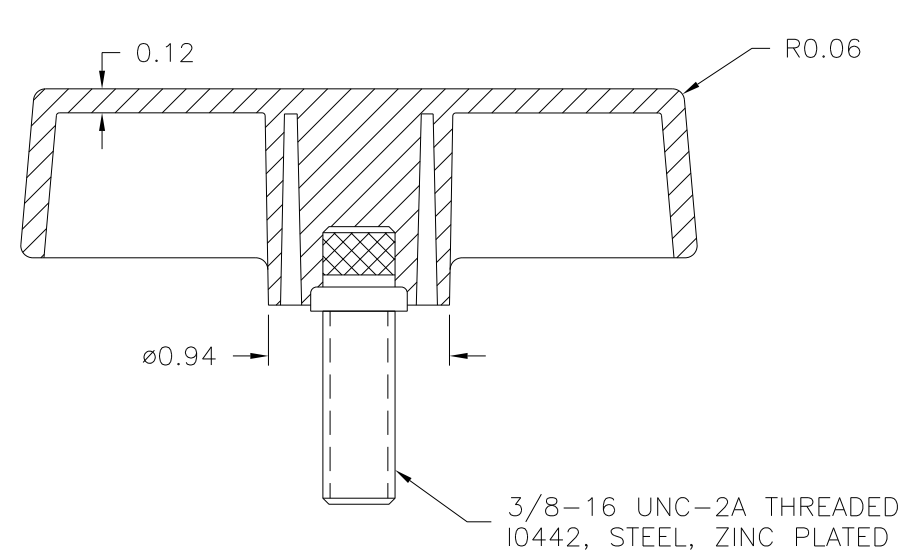
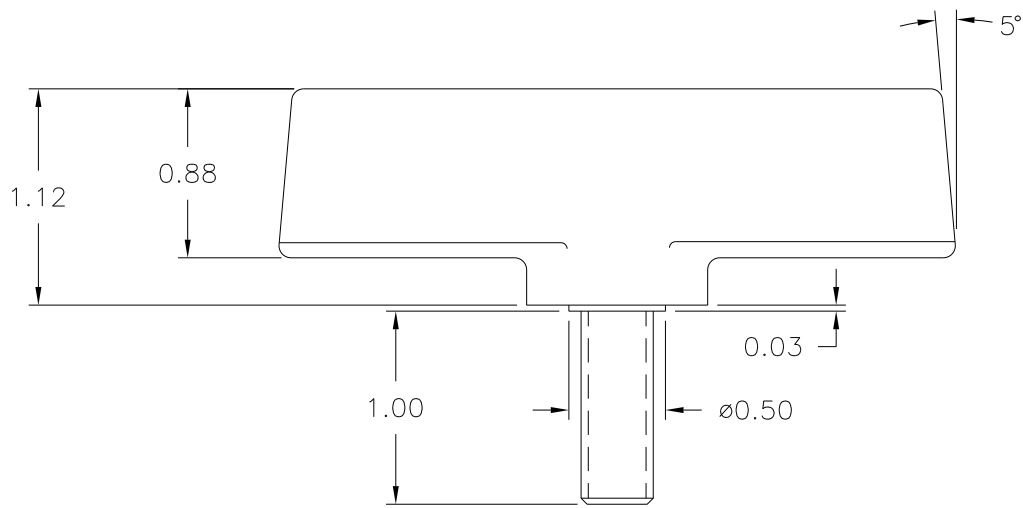
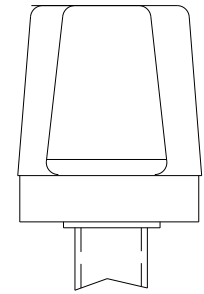
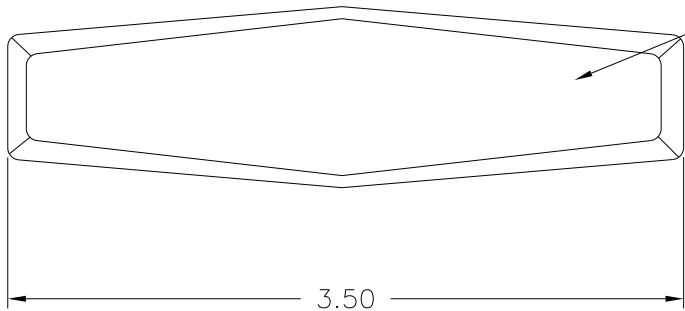

(B) MATERIAL: NYLON 6/6 (ZY2), (ZY6)
OR ENGINEERING APPROVED EQUIVALENT
COLOR: BLACK

TOLERANCES: UNLESS OTHERWISE SPECIFIED	DO NOT SCALE DRAWING	B	ADDED ZY6	JAM	7/13/12
DECIMALS: X.XXX ± .005 X.XX ± .015	MM: X.XX ± 0.15MM X.X ± 0.4MM	A	ADDED MAT. CODE	DS	1/9/07
FRACTIONS ± 1/64	ANG. ± 1°	-	CAD REDRAWN	TL	11/12/99
CHANGES					