

Si4311 DEMO BOARD USER'S GUIDE

1. Overview

The Silicon Laboratories Si4311-DEMO board provides a complete FSK radio design with numerous selectable features that demonstrate the capabilities of the Silicon Laboratories Si4311 FSK receiver. The Si4311-DEMO board can be configured to receive FSK data from an SMA connector or wirelessly with an onboard printed circuit board (PCB) antenna. The demodulated output data from the Si4311-DEMO board can be measured via an SMA connector and/or observed with an LED and/or heard with an audio buzzer. The system is powered by a 9 V battery or an external 3.3 V power supply.

2. Features

- Single chip FSK receiver
- Selectable 315/433.92 MHz carrier frequency
- Selectable data rate, frequency deviation

3. Description

Figures 1 and 2 show the physical layout of the board with key components indicated.



Figure 1. Si4311 DEMO Board Top Side



Figure 2. Si4311 DEMO Board Bottom Side with 9 V Battery

Power Supply Connector

J1: Jumper to select external 3.3 V supply. This is a solderable jumper and should be shorted when used.

J7: External 3.3 V supply connector: +3.3 V with the jumper on the right side and GND on the left side.

J3: 9 V battery supply connector: Power on with the jumper on the right side and power off with the jumper on the left side.

J8: Jumper used to measure Si4311 current consumption.

- Jumper connected (shorted) is normal operation.
- Jumper connected with an ammeter in series to measure current.

D3: Power-on indicator. LED lights up when powered on.

RF Input

J4: SMA connector for an external RF input. Ensure inductor L3 is open to remove the PCB antenna when using the SMA input.

Demodulated Data Output

J5: SMA connector for demodulated data output.

External Clock Driver

J9/J17: These solder jumpers should be shorted when an external clock driver is used.

J10: External clock connection point.

Automatic Frequency Centering (AFC)

J11: Jumper used to select AFC function.

- Logic High (left side connection) to enable AFC.
- Logic Low (right side connection) to disable AFC.

Carrier Frequency Selection

J12: Jumper used to select 315 or 433.92 MHz carrier frequency.

- Logic High (left side connection) for 315 MHz.
- Logic Low (right side connection) for 433.92 MHz.

Bit Time Selection

J13/J14: Two jumpers used for bit time selection.

Table 1. Bit Time Selection

J13	J14	Bit Time [μ s]
0	0	1000
0	1	500
1	0	200
1	1	100

Frequency Deviation Selection

J15/J16: Two jumpers used for frequency deviation selection.

Table 2. Frequency Deviation Selection

J13	J14	Frequency Deviation [kHz]
0	0	30
0	1	50
1	0	70
1	1	90

Key Components

U4: Si4311 single chip FSK receiver.

X1: 16 MHz crystal.

D1: LED lights up when data output present.

B2: Audio buzzer sounds when data output is present.

5. PCB Layout

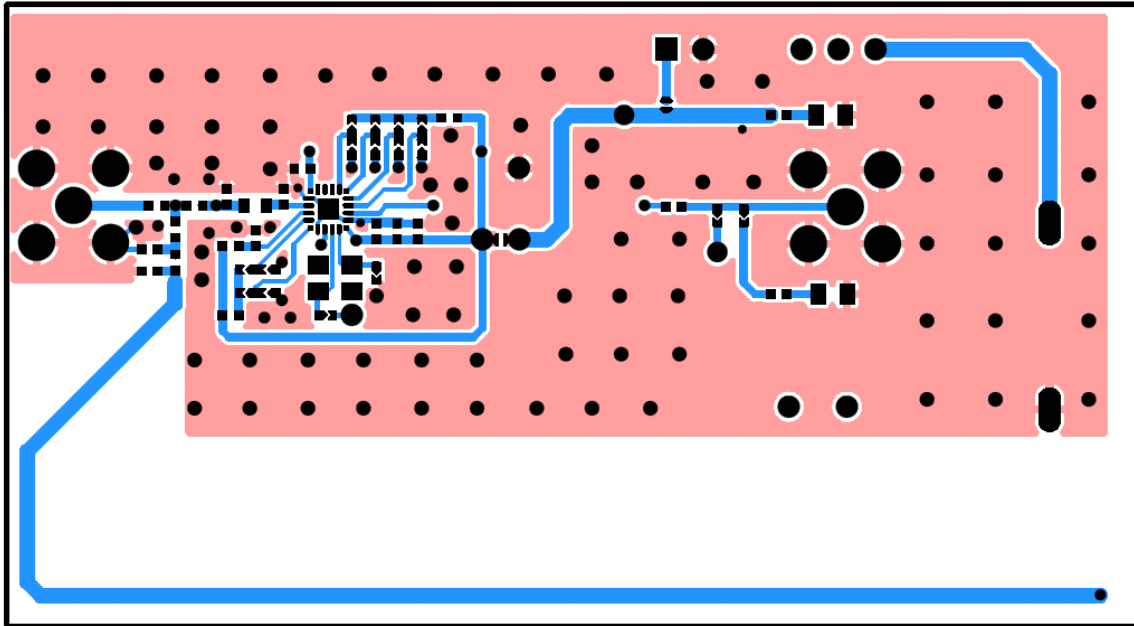

Figure 4. Si4311 PCB Top Layer

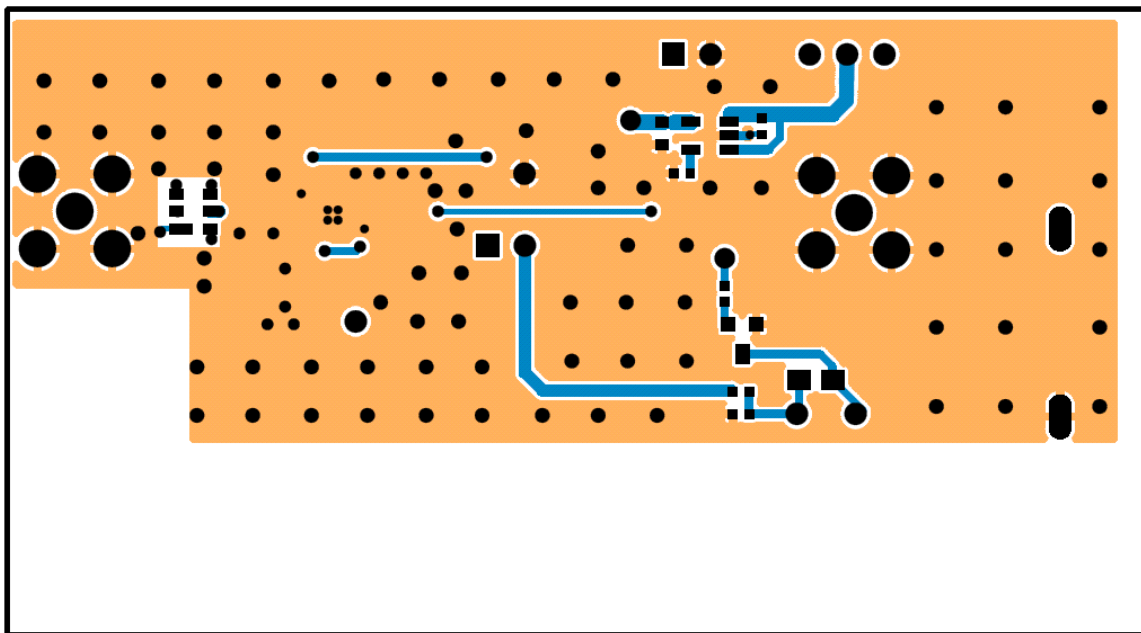

Figure 5. Si4311 PCB Bottom Layer

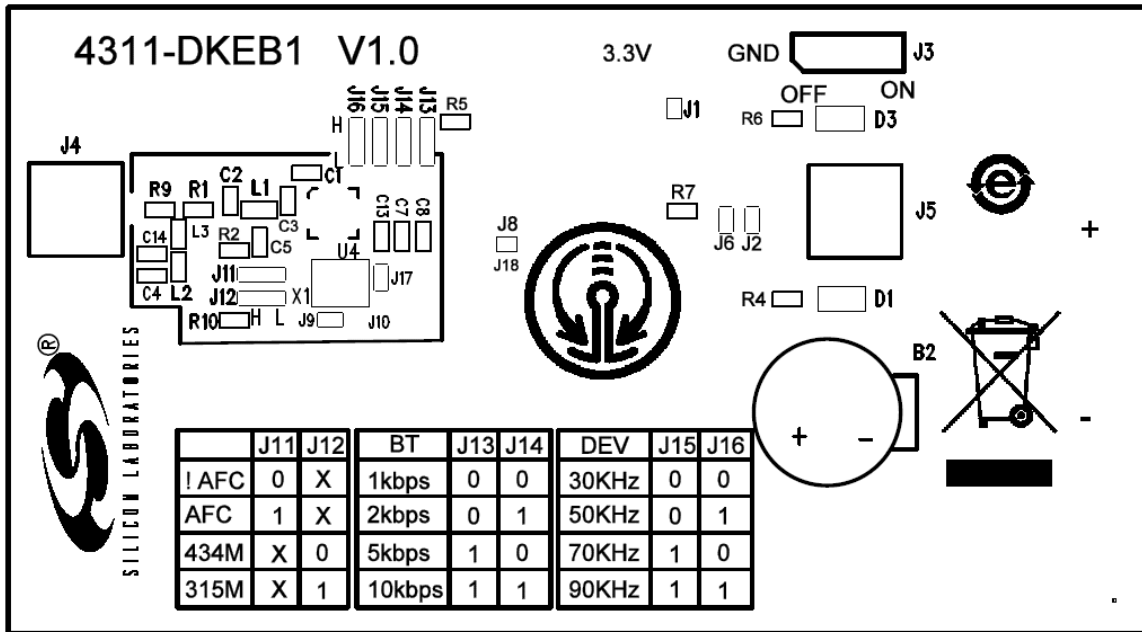

Figure 6. Si4311 PCB Top Silkscreen

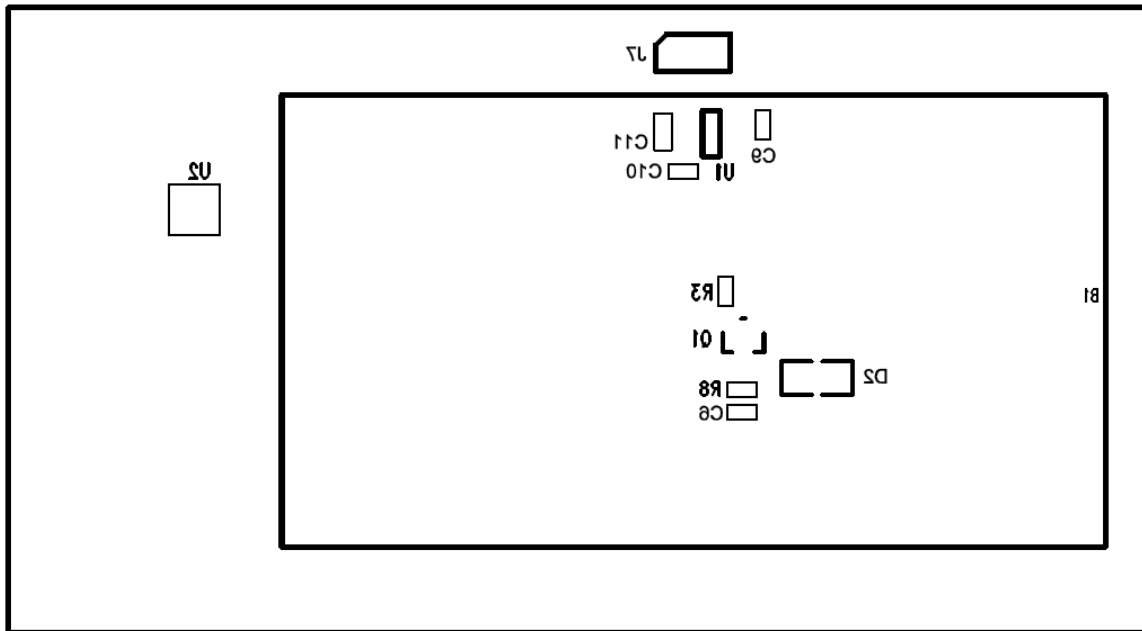

Figure 7. Si4311 PCB Bottom Silkscreen

6. Bill of Materials

Reference	Qty	Package	Value
B1	1	AA_BATTERY	9.0 V
B2	1	BUZZER2	
C1,C7	2	CMS0402	22 nF
C2	1	CMS0603	15 pF
C3,C4	2	CMS0603	NC
C5,C9	2	CMS0402	1 μ F
C6	1	CMS0402	NC
C8	1	CMS0402	0.1 μ F
C10	1	CMS0402	10 nF
C11	1	CMS0603	2.2 μ F
C13	1	CMS0402	220 pF
C14	1	CMS0603	TBD
D1,D3	2	CMS0805	LED
D2	1	CMS0805	IN4148
J3	1	DIP SWITCH	
J4,J5	2	SMA	
J7	1	HEADER2	
L1	1	CMS0402	33 nH
L2	1	CMS0402	TBD
L3	1	CMS0402	0R/NC
Q1	1	SOT23	9013
R1	1	CMS0603	0R
R2	1	CMS0402	20 k Ω
R3,R6	2	CMS0402	1 k Ω
R4	1	CMS0402	330R
R5	1	CMS0402	10 k Ω
R7	1	CMS0402	0R
R8	1	CMS0402	39R
R9	1	CMS0603	NC
U1	1	SOT-23-5	LP2985
U2	1	SC33	SAW filter
U3	1	ANT	
U4	1	MLP20-3MM	Si4311
X1	1	XTAL_32X25	16 MHz

Si4311-DB

7. Receiving Data Status

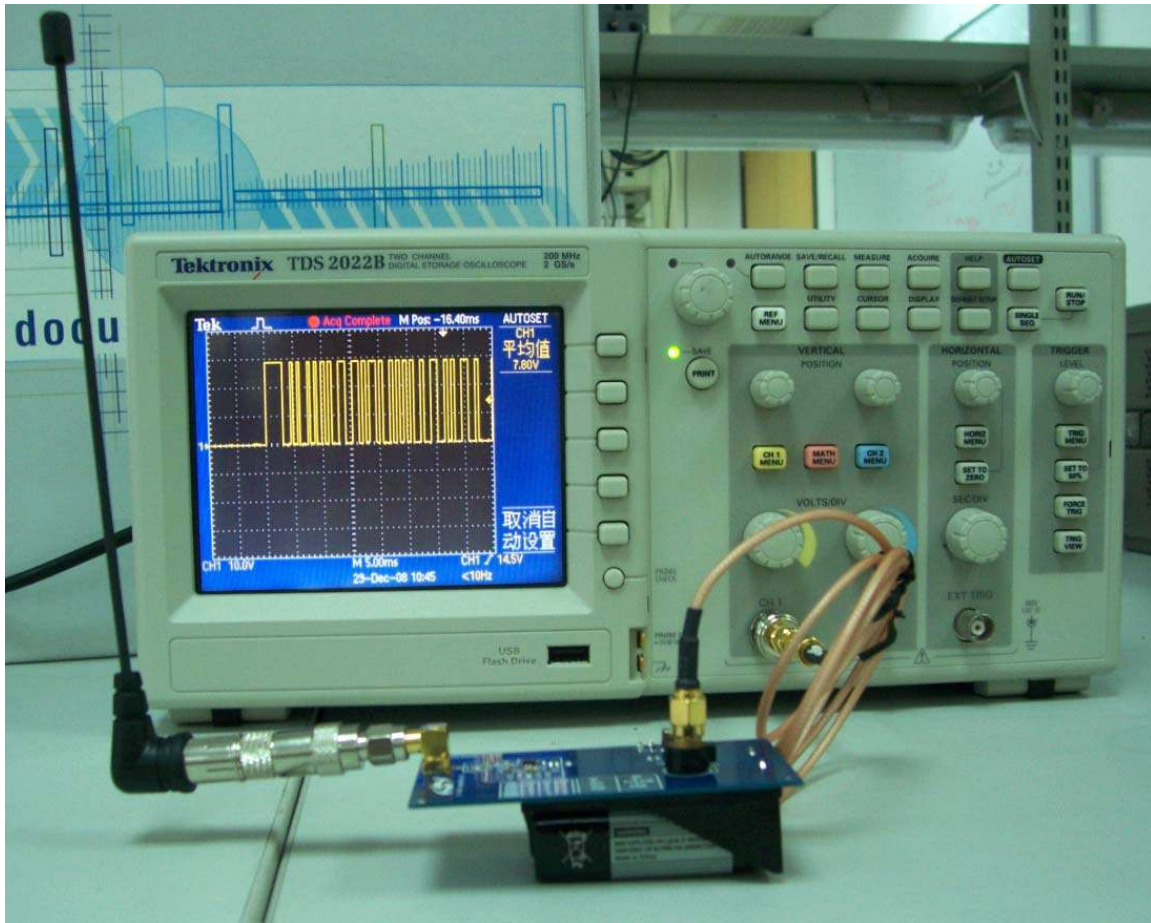

8. References

- Si4311 Data Sheet

NOTES:

CONTACT INFORMATION

Silicon Laboratories Inc.
400 West Cesar Chavez
Austin, TX 78701
Tel: 1+(512) 416-8500
Fax: 1+(512) 416-9669
Toll Free: 1+(877) 444-3032

Please visit the Silicon Labs Technical Support web page:
<https://www.silabs.com/support/pages/contacttechnicalsupport.aspx>
and register to submit a technical support request.

The information in this document is believed to be accurate in all respects at the time of publication but is subject to change without notice. Silicon Laboratories assumes no responsibility for errors and omissions, and disclaims responsibility for any consequences resulting from the use of information included herein. Additionally, Silicon Laboratories assumes no responsibility for the functioning of undescribed features or parameters. Silicon Laboratories reserves the right to make changes without further notice. Silicon Laboratories makes no warranty, representation or guarantee regarding the suitability of its products for any particular purpose, nor does Silicon Laboratories assume any liability arising out of the application or use of any product or circuit, and specifically disclaims any and all liability, including without limitation consequential or incidental damages. Silicon Laboratories products are not designed, intended, or authorized for use in applications intended to support or sustain life, or for any other application in which the failure of the Silicon Laboratories product could create a situation where personal injury or death may occur. Should Buyer purchase or use Silicon Laboratories products for any such unintended or unauthorized application, Buyer shall indemnify and hold Silicon Laboratories harmless against all claims and damages.

Silicon Laboratories and Silicon Labs are trademarks of Silicon Laboratories Inc.
Other products or brandnames mentioned herein are trademarks or registered trademarks of their respective holders.