



IS21TF08G

IS22TF08G

8GB eMMC

With eMMC 5.1 Interface & pSLC Mode NAND

DATA SHEET

8GB eMMC with eMMC 5.1 Interface & pSLC Mode NAND

FEATURES

- Packaged NAND flash memory with eMMC 5.1 interface
 - IS21/22TF08G: 8Gigabyte
- Compliant with eMMC Specification Ver.4.3, 4.4, 4.41,4.5, 4.51, 5.0, 5.1
- Device can be converted to eMMC 4.3, 4.41, 4.51, 5.0 via initializing
- Bus mode
 - High-speed eMMC protocol
 - Clock frequency: 0-200MHz.
 - Ten-wire bus (clock, 1 bit command, 8 bit data bus) and a hardware reset.
- Supports three different data bus widths : 1 bit(default), 4 bits, 8 bits
 - Data transfer rate: up to 52Mbyte/s (using 8 parallel data lines at 52 MHz)
 - Single data rate : up to 200Mbyte/s @ 200MHz (HS200)
 - Dual data rate : up to 400Mbyte/s @ 200MHz (HS400)
- Operating voltage range :
 - VCCQ = 1.8 V/3.3 V (Automotive A2 Grade only supports 1.8V VCCQ)
 - VCC = 2.7 – 3.6V
- Error free memory access
 - Internal error correction code (ECC) to protect data communication
 - Internal enhanced data management algorithm
 - Solid protection from sudden power failure, safe-update operations for data content
- Security
 - Support secure erase and trim commands
 - Enhanced write protection with permanent and partial protection options
- Key Features :
 - HS400, Field Firmware Update (FFU), Power Off Notification, Pre EOL information, Enhanced Device Life time, Optimal Size
- eMMC 5.1 Features:
 - Command Queuing, Enhanced Strobe, Cache Flushing Report, BKOPS Control, Cache Barrier, RPMB Throughput Improve, Secure Write Protection.
- Temperature range
 - Industrial Grade (I): -40 °C ~ 85 °C
 - Automotive Grade (A1): -40 °C ~ 85 °C
 - Automotive Grade (A2): -40 °C ~ 105 °C (The Surface Temperature of Tc cannot be over 115 °C)
- Package
 - 153 FBGA (11.5mm x 13mm x 1.0mm)
 - 100 FBGA (14.0mm x 18.0mm x 1.4mm)



GENERAL DESCRIPTION

ISSI *eMMC* products follow the JEDEC *eMMC* 5.1 standard. It is ideal for embedded storage solutions for Industrial application and automotive application, which require high performance across a wide range of operating temperatures.

eMMC encloses the pSLC Mode NAND and *eMMC* controller inside as one JEDEC standard package, providing a standard interface to the host. The *eMMC* controller directly manages NAND flash, including ECC, wear-leveling, IOPS optimization and read sensing.

TABLE OF CONTENTS

FEATURES.....	2
GENERAL DESCRIPTION.....	3
TABLE OF CONTENTS	4
1. PERFORMANCE SUMMARY.....	6
1.1 Typical Sequential Burst Performance (PSA Pseudo-SLC Burst Status)	6
1.2 Typical Sequential Sustained Performance (Normal Status)	6
1.3 Typical Random Burst Performance (PSA Pseudo SLC Burst Status)	7
1.4 Typical Random Sustained Performance (Normal Status)	7
1.5 Device Power Consumption RMS V_{CC}/V_{CCQ} ($T_A = 25\text{ }^\circ\text{C}$ @ 3.3V/1.8V)	8
1.6 Device Power Consumption Standby V_{CC}/V_{CCQ} ($T_A = 25\text{ }^\circ\text{C}$ @ 3.3V/1.8V)	8
1.7 BOOT PARTITION AND RPMB (REPLAY PROTECTED MEMORY BLOCK)	9
1.8 USER DENSITY	10
2. PIN CONFIGURATION and DDESCRIPTIONS	11
3. OPERATING and STORAGE TEMPERATURE	14
4. eMMC Device and System.....	15
4.1 Memory Addressing	15
5. REGISTER SETTINGS.....	16
5.1 OCR Register	16
5.2 CID Register	16
5.3 CSD Register	16
5.4 Extended CSD Register	19
6. The eMMC BUS	25
6.1 Power-up.....	26
6.1.1 eMMC power-up	26
6.1.2 eMMC Power Cycling	27
6.2 Bus Operating Conditions.....	28
6.2.1 Power supply: eMMC.....	28
6.2.2 eMMC Power Supply Voltage	29
6.2.3 Bus Signal Line Load	30
6.2.4 HS400 reference load	31
6.3 Bus Signal Levels.....	32
6.3.1 Open-drain Mode Bus Signal Level	32
6.3.2 Push-pull mode bus signal level— eMMC	32
6.3.3 Device Output Driver Requirements for HS200 & HS400	33
6.4 Bus Timing.....	33
6.5 Device Interface Timings.....	34
6.6 Bus Timing for DAT Signals During Dual Data Rate Operation	36



6.6.1	Dual Data Rate Interface Timings	36
6.6.2	HS400 Device Input Timing	37
6.6.3	HS400 Device Output Timing	38
7.	eMMC Device Overview	41
7.1	Clock (CLK)	41
7.2	Data Strobe	41
7.3	Command (CMD)	41
7.4	Input/Outputs (DAT0-DAT7)	41
8.	eMMC Functional Description	42
8.1	Pseudo Technology (pSLC)	42
8.2	Field Firmware Update (FFU)	42
8.3	Power Off Notification for Sleep	43
8.4	Enhanced User Data Area	44
8.5	Write Cache	44
8.6	Cache Enhancement Barrier	44
8.7	Cache Flushing Policy	45
8.8	Command Queuing (Disable by default)	46
8.9	Production State Awareness (PSA)	47
9.	PACKAGE TYPE INFORMATION	48
10.	ORDERING INFORMATION – Valid Part Numbers	50

1. PERFORMANCE SUMMARY

1.1 Typical Sequential Burst Performance (PSA Pseudo-SLC Burst Status)

Speed Mode & Operation			8GB	Unit
HS400	Write Cache On	Read	320	MB/s
		Write	135	MB/s
	Write Cache Off	Read	320	MB/s
		Write	130	MB/s
HS200	Write Cache On	Read	175	MB/s
		Write	140	MB/s
	Write Cache Off	Read	175	MB/s
		Write	120	MB/s

Notes:

1. Values for an 8-bit bus width, running ISSI proprietary tool, $V_{CC}=3.3V$, $V_{CCQ}=1.8V$.
2. Performance numbers might be subject to changes without notice.
3. The write cache size is 1536KB.

1.2 Typical Sequential Sustained Performance (Normal Status)

Speed Mode & Operation			8GB	Unit
HS400	Write Cache On	Read	320	MB/s
		Write	135	MB/s
	Write Cache Off	Read	320	MB/s
		Write	125	MB/s
HS200	Write Cache On	Read	175	MB/s
		Write	135	MB/s
	Write Cache Off	Read	175	MB/s
		Write	120	MB/s

Notes:

1. Values for an 8-bit bus width, running HS400 mode, $V_{CC}=3.3V$, $V_{CCQ}=1.8V$.
2. Performance numbers might be subject to changes without notice.
3. The write cache size is 1536KB.

1.3 Typical Random Burst Performance (PSA Pseudo SLC Burst Status)

Speed Mode & Operation			8GB	Unit
HS400	Write Cache On	Read	24,000	IOPS
		Write	28,000	IOPS
	Write Cache Off	Read	24,000	IOPS
		Write	2,400	IOPS
HS200	Write Cache On	Read	24,000	IOPS
		Write	28,000	IOPS
	Write Cache Off	Read	24,000	IOPS
		Write	2,300	IOPS

Notes:

1. Values for an 8-bit bus width, running ISSI proprietary tool, $V_{CC}=3.3V$, $V_{CCQ}=1.8V$.
2. Performance numbers might be subject to changes without notice.
3. The write cache size is 1536KB.

1.4 Typical Random Sustained Performance (Normal Status)

Speed Mode & Operation			8GB	Unit
HS400	Write Cache On	Read	24,000	IOPS
		Write	28,400	IOPS
	Write Cache Off	Read	24,000	IOPS
		Write	2,400	IOPS
HS200	Write Cache On	Read	24,000	IOPS
		Write	28,500	IOPS
	Write Cache Off	Read	24,000	IOPS
		Write	2,300	IOPS

Notes:

1. Values for an 8-bit bus width, running ISSI proprietary tool, $V_{CC}=3.3V$, $V_{CCQ}=1.8V$.
2. Performance numbers might be subject to changes without notice.
3. The write cache size is 1536KB.

1.5 Device Power Consumption RMS V_{CC}/V_{CCQ} ($T_A = 25\text{ }^\circ\text{C}$ @ 3.3V/1.8V)

Speed Mode & Operation			8GB	Unit
HS400	Read	I _{CC}	55	mA
		I _{CCQ}	220	mA
	Write	I _{CC}	55	mA
		I _{CCQ}	120	mA
HS200	Read	I _{CC}	40	mA
		I _{CCQ}	220	mA
	Write	I _{CC}	55	mA
		I _{CCQ}	120	mA

Notes:

1. The measurement for RMS current is done as average RMS current consumption over a period of 100ms.
2. Current numbers might be subject to changes without notice.

1.6 Device Power Consumption Standby V_{CC}/V_{CCQ} ($T_A = 25\text{ }^\circ\text{C}$ @ 3.3V/1.8V)

Speed Mode & Operation			8GB	Unit
HS400	CMD5 Sleep		190	uA
	Standby I _{CCQ}		240	uA
	Standby I _{CC}		30	uA
HS200	CMD5 Sleep		190	uA
	Standby I _{CCQ}		240	uA
	Standby I _{CC}		30	uA

Notes:

1. The current is measured at $V_{CC} = 3.3V \pm 5\%$, $V_{CCQ} = 1.8V \pm 5\%$, 8-bit bus width without clock frequency..
2. Current numbers might be subject to changes without notice.

1.7 BOOT PARTITION AND RPMB (REPLAY PROTECTED MEMORY BLOCK)

Option	Boot partition 1	Boot partition 2	RPMB
J	4,096 KB	4,096 KB	4,096 KB
B	16,384 KB	16,384 KB	4,096 KB



1.8 USER DENSITY

Total user density depends on device type (Flash Mode).

Part Number	Capacity	Flash Mode	User Density Size
IS/2122TF08G	8GB	pSLC	7,817,134,080 Bytes

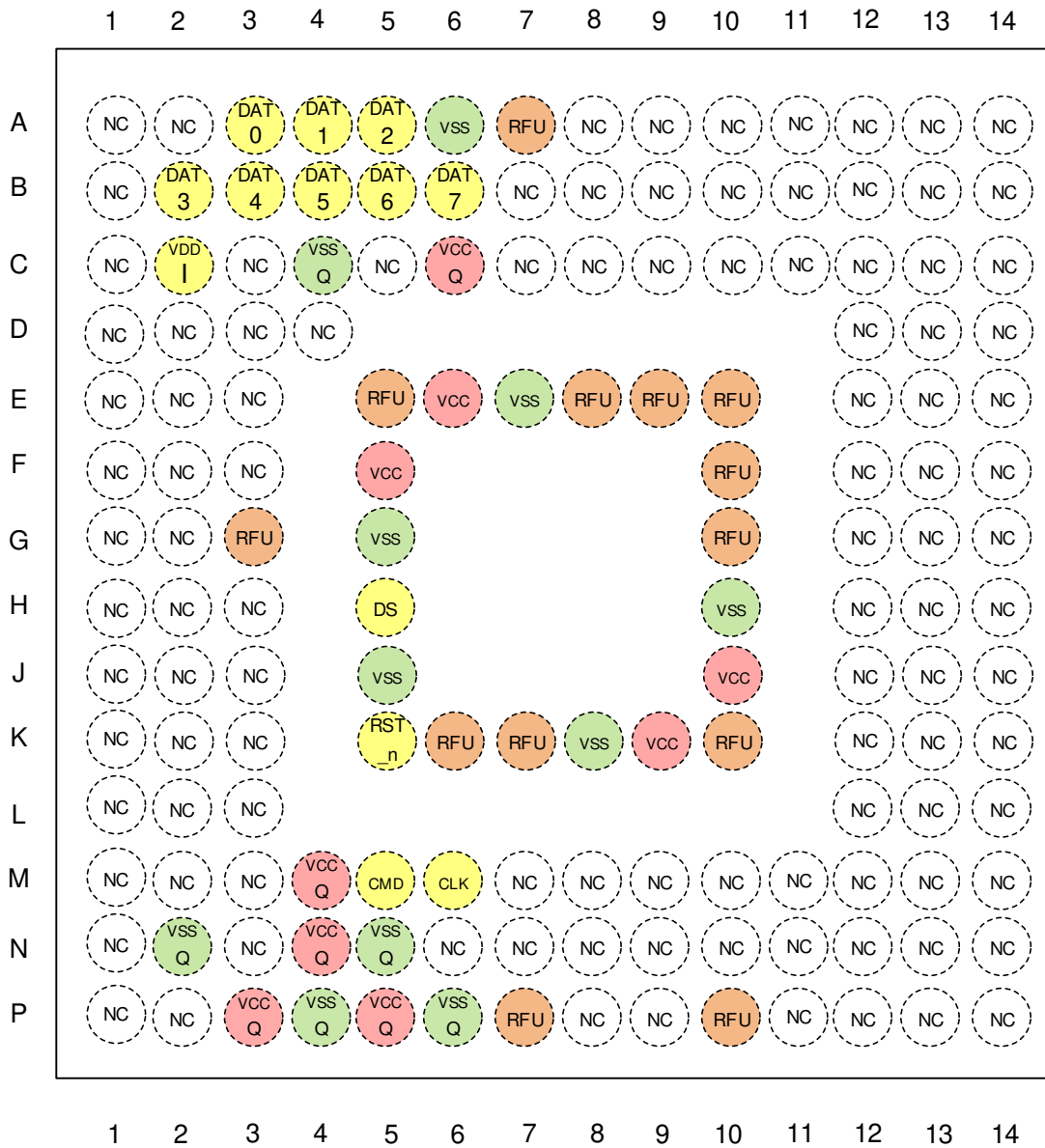
2. PIN CONFIGURATION and DDESCRIPTIONS
153 FBGA Top View (Ball Down)

Note:

- H5 (DS), A6 (VSS) and J5 (VSS) can be left floating if HS400 mode is not used.

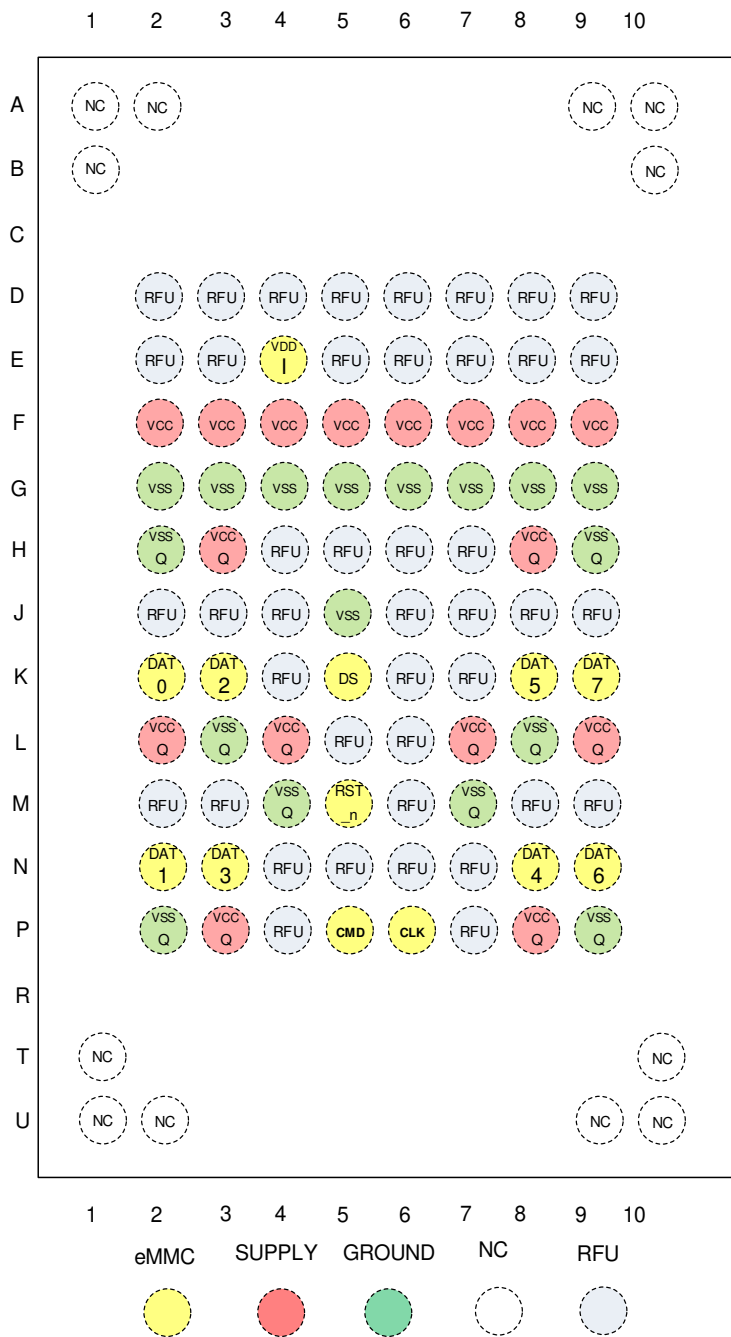
100 FBGA Top View (Ball Down)



Note:
 1. K5 (DS) and J5 (VSS) can be left floating if HS400 mode is not used.

PIN DESCRIPTIONS

Pin Name	Description
CLK	Clock Signal
DAT0~DAT7	Data Bus
CMD	Command Signal
RST#	Hardware Reset Signal
DS	Data Strobe Signal, used in HS400 mode.
VDDI	Connect capacitor from VDDI to GND for stabilize internal power.
VCC	Supply voltage for controller and Flash memory power.
VCCQ	Supply voltage for controller and Flash memory I/O power.
VSS	Supply voltage ground for controller and Flash memory. Can be short with VSSQ.
VSSQ	Supply voltage ground for controller and Flash memory I/O. Can be short with VSSQ.
RFU	Reserved For Future Use. Left it floating for future use.
NC	In eMMC chip is no connect. Left it floating.

Note:

1. I: input; O: output; PP: push-pull; OD: open-drain; NC: Not connected (or logical high); S: power

3. OPERATING and STORAGE TEMPERATURE

Grade	Condition	Temperature
Industrial	Minimum and Maximum Ambient Temperature ⁽¹⁾	-40 °C to 85 °C
	Maximum Case Temperature ⁽¹⁾	95 °C
	Minimum and Maximum Non-operating Temperature ⁽²⁾	-40 °C to 85 °C
Auto (A1)	Minimum and Maximum Ambient Temperature ⁽¹⁾	-40 °C to 85 °C
	Maximum Case Temperature ⁽¹⁾	95 °C
	Minimum and Maximum Non-operating Temperature ⁽²⁾	-40 °C to 85 °C
Auto (A2)	Minimum and Maximum Ambient Temperature ⁽¹⁾	-40 °C to 105 °C
	Maximum Case Temperature ⁽¹⁾	115 °C
	Minimum and Maximum Non-operating Temperature ⁽²⁾	-40 °C to 105 °C

Notes:

1. To achieve optimized and performance, case temperature should not exceed maximum ambient operating temperature.
2. After being soldered onto PCBA.

4. eMMC Device and System

eMMC consists of a single chip MMC controller and NAND flash memory module. The micro-controller interfaces with a host system allowing data to be written to and read from the NAND flash memory module. The controller allows the host to be independent from details of erasing and programming the flash memory.

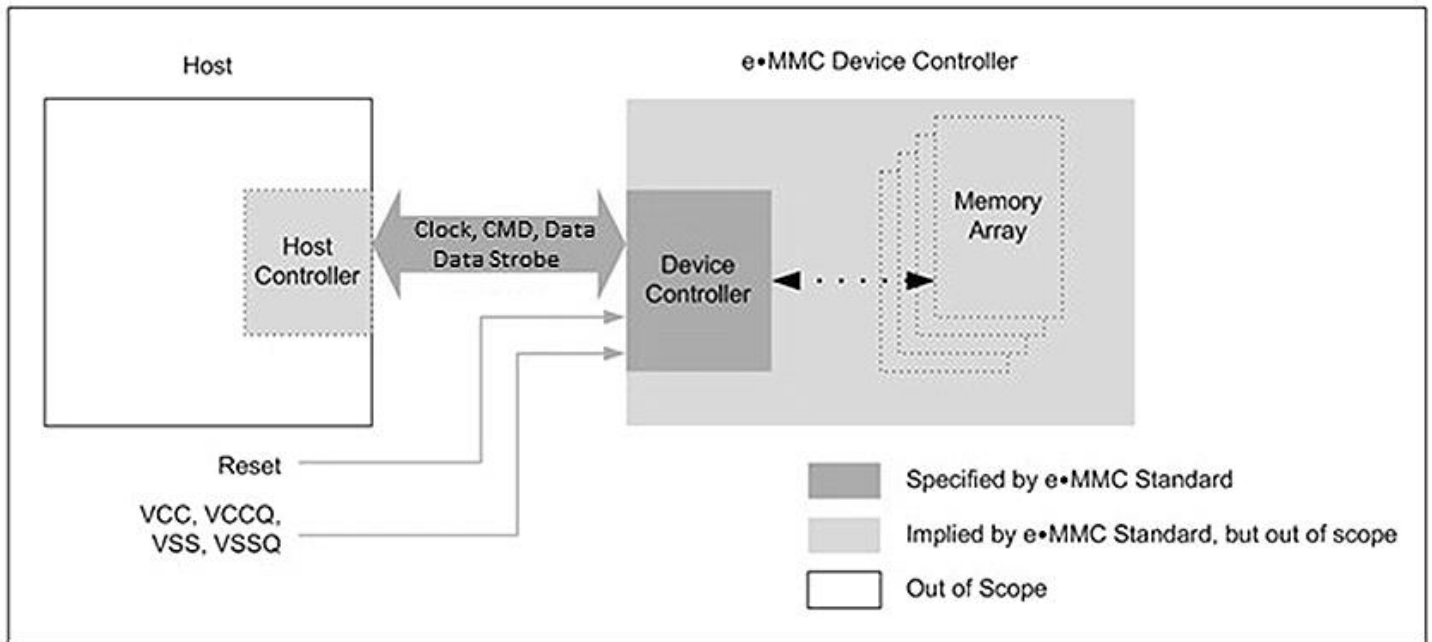

Figure 4.1 eMMC System Overview

4.1 Memory Addressing

Previous implementations of the eMMC specification are following byte addressing with 32-bit field. This addressing mechanism permitted for eMMC densities up to and including 2 GB.

To support larger density, the addressing mechanism was update to support sector addresses (512 B sectors). The sector addresses shall be used for all devices with capacity larger than 2 GB.

To determine the addressing mode, use the host should read bit [30:29] in the OCR register.

5. REGISTER SETTINGS

Within the Device interface six registers are defined: OCR, CID, CSD, EXT_CSD, RCA and DSR. These can be accessed only by corresponding commands (see Section 6.10 of JESD84-B51).

5.1 OCR Register

The 32-bit operation conditions register (OCR) stores the VDD voltage profile of the Device and the access mode indication. In addition, this register includes a status information bit. This status bit is set if the Device power up procedure has been finished. The OCR register shall be implemented by all Devices.

Table 5.1 OCR Register

VCCQ Voltage Window	Width (Bits)	OCR Bit	OCR Value
Device power up status bit (busy) ⁽¹⁾	1	[31]	Note 1
Access Mode	2	[30:29]	10b (sector mode)
Reserved	5	[28:24]	0 0000b
VCCQ: 2.7 – 3.6V	9	[23:15]	1 1111 1111b
VCCQ: 2.0 – 2.6V	7	[14:8]	000 0000b
VCCQ: 1.7 – 1.95V	1	[7]	1b
Reserved	7	[6:0]	000 0000b

Note:

1. This bit is set to LOW if the device has not finished the power up routine.

5.2 CID Register

The Card Identification (CID) register is 128 bits wide. It contains the Device identification information used during the Device identification phase (*eMMC* protocol).

Table 5.2 CID Register

Name	Field	Width (Bits)	CID Bits	CID Value
Manufacturer ID	MID	8	[127:120]	9Dh
Reserved	-	6	[119:114]	0h
Device/BGA	CBX	2	[113:112]	1h
OEM/application ID	OID	8	[111:104]	1h
Product name	PNM 8GB	48	[103:56]	IS008G
Product Revision	PRV	8	[55:48]	51h
Product Serial Number	PSN	32	[47:16]	Random by Production
Manufacturing Date	MDT	8	[15:8]	Month, Year
CRC7 Checksum	CRC	7	[7:1]	- ⁽¹⁾
Not used, always "1"	-	1	[0]	1h

Note:

1. The description is same as *eMMC*™ JEDEC standard.

5.3 CSD Register

The Card-Specific Data (CSD) register provides information on how to access the contents stored in *eMMC*. The CSD registers are used to define the error correction type, maximum data access time, data transfer speed, data format...etc. For details, refer to section 7.3 of the JEDEC Standard Specification No.JESD84-B51.

Table 5.3 CSD Register



Name	Field	Width	Cell Type	CSD-slice	Value
CSD structure	CSD_STRUCTURE	2	R	[127:126]	3h
System specification version	SPEC_VERS	4	R	[125:122]	4h
Reserved	-	2	R	[121:120]	0h
Data read access-time 1	TAAC	8	R	[119:112]	4Fh
Data read access-time 2 in CLK cycles (NSAC*100)	NSAC	8	R	[111:104]	1h
Max. bus clock frequency	TRAN_SPEED	8	R	[103:96]	32h
Device command classes	CCC	12	R	[95:84]	8F5h
Max. read data block length	READ_BL_LEN	4	R	[83:80]	9h
Partial blocks for read allowed	READ_BL_PARTIAL	1	R	[79:79]	0h
Write block misalignment	WRITE_BLK_MISALIGN	1	R	[78:78]	0h
Read block misalignment	READ_BLK_MISALIGN	1	R	[77:77]	0h
DSR implemented	DSR_IMP	1	R	[76:76]	0h
Reserved	-	2	R	[75:74]	0h
Device size	C_SIZE	12	R	[73:62]	FFFh
Max. read current @ VDD min	VDD_R_CURR_MIN	3	R	[61:59]	7h
Max. read current @ VDD max	VDD_R_CURR_MAX	3	R	[58:56]	7h
Max. write current @ VDD min	VDD_W_CURR_MIN	3	R	[55:53]	7h
Max. write current @ VDD max	VDD_W_CURR_MAX	3	R	[52:50]	7h
Device size multiplier	C_SIZE_MULT	3	R	[49:47]	7h
Erase group size	ERASE_GRP_SIZE	5	R	[46:42]	1Fh
Erase group size multiplier	ERASE_GRP_MULT	5	R	[41:37]	1Fh
Write protect group size	WP_GRP_SIZE	5	R	[36:32]	0Fh
Write protect group enable	WP_GRP_ENABLE	1	R	[31:31]	1h
Manufacturer default ECC	DEFAULT_ECC	2	R	[30:29]	0h
Write speed factor	R2W_FACTOR	3	R	[28:26]	2h
Max. write data block length	WRITE_BL_LEN	4	R	[25:22]	9h
Partial blocks for write allowed	WRITE_BL_PARTIAL	1	R	[21:21]	0h
Reserved	-	4	R	[20:17]	0h

Name	Field	Width	Cell Type	CSD-slice	Value
Content protection application	CONTENT_PROT_APP	1	R	[16:16]	0h
File format group	FILE_FORMAT_GRP	1	R/W	[15:15]	0h
Copy flag (OTP)	COPY	1	R/W	[14:14]	0h
Permanent write protection	PERM_WRITE_PROTECT	1	R/W	[13:13]	0h
Temporary write protection	TMP_WRITE_PROTECT	1	R/W/E	[12:12]	0h
File format	FILE_FORMAT	2	R/W	[11:10]	0h
ECC code	ECC	2	R/W/E	[9:8]	0h
CRC	CRC	7	R/W/E	[7:1]	2Eh
Not used, always '1'	-	1	-	[0:0]	1h

5.4 Extended CSD Register

The Extended CSD register defines the Device properties and selected modes. It is 512 bytes long. The most significant 320 bytes are the Properties segment, which defines the Device capabilities and cannot be modified by the host. The lower 192 bytes are the Modes segment, which defines the configuration the Device is working in. These modes can be changed by the host by means of the SWITCH command.

Table 5.4 ECSD Register

Name	Field	Size (Bytes)	CSD-slice	Value
Properties Segment				
Reserved	–	6	[511:506]	0h
Extended Security Commands Error	EXT_SECURITY_ERR	1	[505]	0h
Supported Command Sets	S_CMD_SET	1	[504]	1h
HPI features	HPI_FEATURES	1	[503]	1h
Background operations support	BKOPS_SUPPORT	1	[502]	1h
Max packed read commands	MAX_PACKED_READS	1	[501]	20h
Max packed write commands	MAX_PACKED_WRITES	1	[500]	20h
Data Tag Support	DATA_TAG_SUPPORT	1	[499]	1h
Tag Unit Size	TAG_UNIT_SIZE	1	[498]	3h
Tag Resources Size	TAG_RES_SIZE	1	[497]	0h
Context management capabilities	CONTEXT_CAPABILITIES	1	[496]	5h
Large Unit size	LARGE_UNIT_SIZE_M1	1	[495]	18h
Extended partitions attribute support	EXT_SUPPORT	1	[494]	3h
Supported modes	SUPPORTED_MODES	1	[493]	3h
FFU features	FFU_FEATURES	1	[492]	0h
Operation codes timeout	OPERATION_CODE_TIMEOUT	1	[491]	0h
FFU Argument	FFU_ARG	4	[490:487]	0h
Barrier support	BARRIER_SUPPORT	1	[486]	0h
Reserved	Reserved	177	[485:309]	0h
CMDQ support	CMDQ_SUPPORT	1	[308]	1h
CMDQ depth	CMDQ_DEPTH	1	[307]	1Fh
Reserved	Reserved	1	[306]	0h
Number of FW sectors correctly programmed	NUMBER_OF_FW_SECTORS_CORRECTLY_PROGRAMMED	4	[305:302]	0h
Vendor proprietary health report	VENDOR_PROPRIETARY_HEALTH_REPORT	32	[301:270]	–
Device life time estimation type B	DEVICE_LIFE_TIME_EST_TYPE_B	1	[269]	1h
Device life time estimation type A	DEVICE_LIFE_TIME_EST_TYPE_A	1	[268]	1h
Pre EOL information	PRE_EOL_INFO	1	[267]	1h
Optimal read size	OPTIMAL_READ_SIZE	1	[266]	1h
Optimal write size	OPTIMAL_WRITE_SIZE	1	[265]	8h

Name	Field	Size (Bytes)	CSD-slice	Value
Optimal trim unit size	OPTIMAL_TRIM_UNIT_SIZE	1	[264]	1h
Device version	DEVICE_VERSION	2	[263:262]	0h
Firmware version	FIRMWARE_VERSION	8	[261:254]	– (note 5)



Power class for 200MHz, DDR at VCC=3.6V	PWR_CL_DDR_200_360	1	[253]	0h	
Cache size	CACHE_SIZE	4	[252:249]	600h	
Generic CMD6 timeout	GENERIC_CMD6_TIME	1	[248]	Ah	
Power off notification(long) timeout	POWER_OFF_LONG_TIME	1	[247]	32h	
Background operations status	BKOPS_STATUS	1	[246]	0h	
Number of correctly programmed sectors	CORRECTLY_PRG_SECTORS_NUM	4	[245:242]	0h	
1st initialization time after partitioning	INI_TIMEOUT_AP	1	[241]	1Eh	
Cache Flushing Policy	CACHE_FLUSH_POLICY	1	[240]	1h	
Power class for 52MHz, DDR at 3.6V	PWR_CL_DDR_52_360	1	[239]	0h	
Power class for 52MHz, DDR at 1.95V	PWR_CL_DDR_52_195	1	[238]	0h	
Power class for 200MHz at 3.6V	PWR_CL_200_360	1	[237]	0h	
Power class for 200MHz, at 1.95V	PWR_CL_200_195	1	[236]	0h	
Minimum Write Performance for 8bit at 52MHz in DDR mode	MIN_PERF_DDR_W_8_52	1	[235]	4Bh	
Minimum Read Performance for 8bit at 52MHz in DDR mode	MIN_PERF_DDR_R_8_52	1	[234]	0h	
Reserved	-	1	[233]	0h	
TRIM Multiplier	TRIM_MULT	1	[232]	12h	
Secure Feature support	SEC_FEATURE_SUPPORT	1	[231]	55h	
Secure Erase Multiplier	SEC_ERASE_MULT	1	[230]	64h	
Secure TRIM Multiplier	SEC_TRIM_MULT	1	[229]	64h	
Boot information	BOOT_INFO	1	[228]	7h	
Reserved	-	1	[227]	0h	
Boot partition size	BOOT_SIZE_MULT	J-option	1	[226]	20h
		B-option			80h
Access size	ACC_SIZE	1	[225]	7h	
High-capacity erase unit size	HC_ERASE_GRP_SIZE	1	[224]	1h	
High-capacity erase timeout	ERASE_TIMEOUT_MULT	1	[223]	12h	
Reliable write sector count	REL_WR_SEC_C	1	[222]	1h	
High-capacity write protect group size	HC_WP_GRP_SIZE	1	[221]	10h	
Sleep current (VCC)	S_C_VCC	1	[220]	8h	



Name	Field	Size (Bytes)	CSD-slice	Value
Sleep current (VCCQ)	S_C_VCCQ	1	[219]	8h
Production state awareness Timeout	PRODUCTION_STATE_AWARENESS_TIMEOUT	1	[218]	0h
Sleep/awake timeout	S_A_TIMEOUT	1	[217]	15h
Sleep Notification timeout	SLEEP_NOTIFICATION_TIME	1	[216]	Fh
Sector Count	SEC_COUNT	4	[215:212]	15267840
Security write protect information	SECURE_WP_INFO	1	[211]	1h
Minimum Write Performance for 8bit at 52MHz	MIN_PERF_W_8_52	1	[210]	4Bh
Minimum Read Performance for 8bit at 52MHz	MIN_PERF_R_8_52	1	[209]	0h
Minimum Write Performance for 8bit at 26MHz, for 4bit at 52MHz	MIN_PERF_W_8_26_4_52	1	[208]	2Bh
Minimum Read Performance for 8bit at 26MHz, for 4bit at 52MHz	MIN_PERF_R_8_26_4_52	1	[207]	0h
Minimum Write Performance for 4bit at 26MHz	MIN_PERF_W_4_26	1	[206]	1Eh
Minimum Read Performance for 4bit at 26MHz	MIN_PERF_R_4_26	1	[205]	0h
Reserved	–	1	[204]	0h
Power class for 26MHz at 3.6V 1 R	PWR_CL_26_360	1	[203]	0h
Power class for 52MHz at 3.6V 1 R	PWR_CL_52_360	1	[202]	0h
Power class for 26MHz at 1.95V 1 R	PWR_CL_26_195	1	[201]	0h
Power class for 52MHz at 1.95V 1 R	PWR_CL_52_195	1	[200]	0h
Partition switching timing	PARTITION_SWITCH_TIME	1	[199]	3h
Out-of-interrupt busy timing	OUT_OF_INTERRUPT_TIME	1	[198]	Ah
I/O Driver Strength	DRIVER_STRENGTH	1	[197]	1Fh
Device type	CARD_TYPE	1	[196]	57h
Reserved	–	1	[195]	0h
CSD structure version	–	1	[194]	2h
Reserved	–	1	[193]	0h
Extended CSD revision	EXT_CSD_REV	1	[192]	8h
Modes Segment				
Command set	CMD_SET	1	[191]	0h
Reserved	–	1	[190]	0h

Name	Field	Size (Bytes)	CSD-slice	Value
Command set revision	CMD_SET_REV	1	[189]	0h
Reserved	–	1	[188]	0h
Power class	POWER_CLASS	1	[187]	0h
Reserved	–	1	[186]	0h
High-speed interface timing	HS_TIMING	1	[185]	1h (note 3)
Strobe support	STROBE_SUPPORT	1	[184]	1h
Bus width mode	BUS_WIDTH	1	[183]	2h (note 4)
Reserved	–	1	[182]	0h
Erased memory content	ERASED_MEM_CONT	1	[181]	0h
Reserved	–	1	[180]	0h



Partition configuration	PARTITION_CONFIG	1	[179]	0h
Boot config protection	BOOT_CONFIG_PROT	1	[178]	0h
Boot bus Conditions	BOOT_BUS_CONDITIONS	1	[177]	0h
Reserved	–	1	[176]	0h
High-density erase group definition	ERASE_GROUP_DEF	1	[175]	0h
Boot write protection status registers	BOOT_WP_STATUS	1	[174]	0h
Boot area write protection register	BOOT_WP	1	[173]	0h
Reserved	–	1	[172]	0h
User area write protection register	USER_WP	1	[171]	0h
Reserved	–	1	[170]	1Eh
FW configuration	FW_CONFIG	1	[169]	0h
RPMB Size	RPMB_SIZE_MULT	1	[168]	20h
Write reliability setting register	WR_REL_SET	1	[167]	1Fh
Write reliability parameter register	WR_REL_PARAM	1	[166]	15h
Start Sanitize operation	SANITIZE_START	1	[165]	0h
Manually start background operations	BKOPS_START	1	[164]	0h
Enable background operations handshake	BKOPS_EN	1	[163]	2h
H/W reset function	RST_n_FUNCTION	1	[162]	0h
HPI management	HPI_MGMT	1	[161]	0h
Partitioning Support	PARTITIONING_SUPPORT	1	[160]	7h
Max Enhanced Area Size	MAX_ENH_SIZE_MULT	3	[159:157]	3A8h
Partitions attribute	PARTITIONS_ATTRIBUTE	1	[156]	1h
Partitioning Setting	PARTITION_SETTING_COMPLETED	1	[155]	1h



Name	Field	Size (Bytes)	CSD-slice	Value
General Purpose Partition Size	GP_SIZE_MULT4	3	[154:152]	0h
General Purpose Partition Size	GP_SIZE_MULT3	3	[151:149]	0h
General Purpose Partition Size	GP_SIZE_MULT2	3	[148:146]	0h
General Purpose Partition Size	GP_SIZE_MULT1	3	[145:143]	0h
Enhanced User Data Area Size	ENH_SIZE_MULT	3	[142:140]	3A8h
Enhanced User Data Start Address	ENH_START_ADDR	4	[139:136]	0h
Reserved	–	1	[135]	0h
Bad Block Management mode	SEC_BAD_BLK_MGMNT	1	[134]	0h
Production state awareness	PRODUCTION_STATE_AWARENESS	1	[133]	0h
Package Case Temperature is controlled	TCASE_SUPPORT	1	[132]	0h
Periodic Wake-up	PERIODIC_WAKEUP	1	[131]	0h
Program CID/CSD in DDR mode support	PROGRAM_CID_CSD_DDR_SUPPORT	1	[130]	1h
Reserved	–	2	[129:128]	0h
Vendor Specific Fields	VENDOR_SPECIFIC_FIELD	61	[127:67]	–
Error code	ERROR_CODE	2	[66:65]	0h
Error type	ERROR_TYPE	1	[64]	0h
Native sector size	NATIVE_SECTOR_SIZE	1	[63]	0h
Sector size emulation	USE_NATIVE_SECTOR	1	[62]	0h
Sector size	DATA_SECTOR_SIZE	1	[61]	0h
1st initialization after disabling sector size emulation	INI_TIMEOUT_EMU	1	[60]	0h
Class 6 commands control	CLASS_6_CTRL	1	[59]	0h
Number of addressed group to be Released	DYNCAP_NEEDED	1	[58]	0h
Exception events control	EXCEPTION_EVENTS_CTRL	2	[57:56]	0h
Exception events status	EXCEPTION_EVENTS_STATUS	2	[55:54]	0h
Extended Partitions Attribute	EXT_PARTITIONS_ATTRIBUTE	2	[53:52]	0h
Context configuration	CONTEXT_CONF	15	[51:37]	-
Packed command status	PACKED_COMMAND_STATUS	1	[36]	0h
Packed command failure index	PACKED_FAILURE_INDEX	1	[35]	0h
Power Off Notification	POWER_OFF_NOTIFICATION	1	[34]	0h
Control to turn the Cache ON/OFF	CACHE_CTRL	1	[33]	0h
Flushing of the cache	FLUSH_CACHE	1	[32]	0h
Reserved	Reserved	1	[31]	0h
Mode config	MODE_CONFIG	1	[30:30]	0h

Name	Field	Size (Bytes)	CSD-slice	Value
Mode operation codes	MODE_OPERATION_CODES	1	[29:29]	0h
Reserved	Reserved	2	[28:27]	0h
FFU status	FFU_STATUS	1	[26:26]	0h
Per loading data size	PRE_LOADING_DATA_SIZE	4	[25:22]	0h
Max pre loading data size	MAX_PRE_LOADING_DATA_SIZE	4	[21:18]	4843520
Product state awareness enablement	PRODUCT_STATE_AWARENESS_ENABLEMENT	1	[17:17]	1h
Secure removal type	SECURE_REMOVAL_TYPE	1	[16:16]	01h
Command Queue Mode enable	CMQ_MODE_EN	1	[15:15]	0h
Reserved	Reserved	15	[14:0]	0h

Notes:

1. Reserved bits should read as "0".
2. Obsolete values should be don't care.
3. This field is 0 after power-on, H/W reset or software reset, thus selecting the backwards compatible interface timing for the Device. If the host sets 1 to this field, the Device changes the timing to high speed interface timing (see Section 10.6.1 of JESD84-B50). If the host sets value 2, the Device changes its timing to HS200 interface timing (see Section 10.8.1 of JESD854-B50). If the host sets HS_TIMING [3:0] to 0x3, the device changes it's timing to HS400 interface timing (see 10.10).
4. It is set to "0" (1bit data bus) after power up and can be changed by a SWITCH command.
5. Could be changed by Firmware release note.

6. The eMMC BUS

The eMMC bus has ten communication lines and three supply lines:

- CMD : Command is a bidirectional signal. The host and Device drivers are operating in two modes, open drain and push/pull.
- DAT0-7 : Data lines are bidirectional signals. Host and Device drivers are operating in push-pull mode
- CLK : Clock is a host to Device signal. CLK operates in push-pull mode
- Data Strobe: Data Strobe is a Device to host signal. Data Strobe operates in push-pull mode.

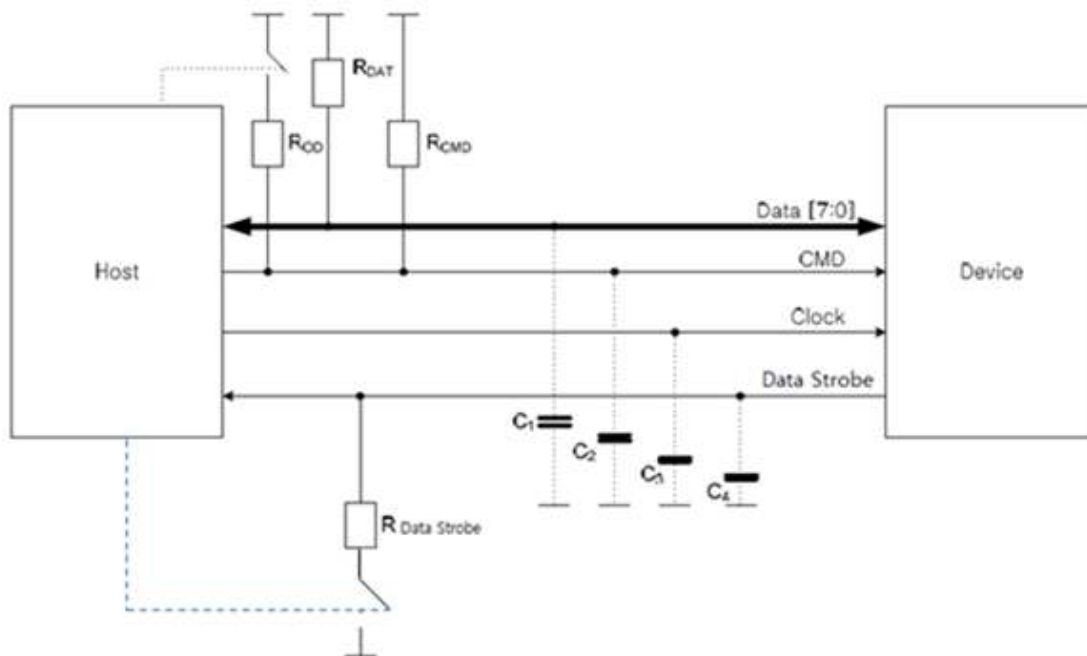

Figure 6.1 BUS Circuitry Diagram

The R_{OD} is switched on and off by the host synchronously to the open-drain and push-pull mode transitions. The host does not have to have open drain drivers, but must recognize this mode to switch on the R_{OD} . R_{DAT} and R_{CMD} are pull-up resistors protecting the CMD and the DAT lines against bus floating device when all device drivers are in a high-impedance mode.

A constant current source can replace the R_{OD} by achieving a better performance (constant slopes for the signal rising and falling edges). If the host does not allow the switchable R_{OD} implementation, a fixed R_{CMD} can be used). Consequently the maximum operating frequency in the open drain mode has to be reduced if the used R_{CMD} value is higher than the minimal one given in.

$R_{Data\ strobe}$ is pull-down resistor used in HS400 device.

6.1 Power-up

6.1.1 eMMC power-up

The power up of the eMMC bus is handled locally in the Device and in the bus master. **Error! Reference source not found.** 6 shows the power-up sequence and is followed by specific instructions regarding the power-up sequence. Refer to section 10.1 of the JEDEC Standard Specification JESD84-B51 for specific instructions regarding the power-up sequence.

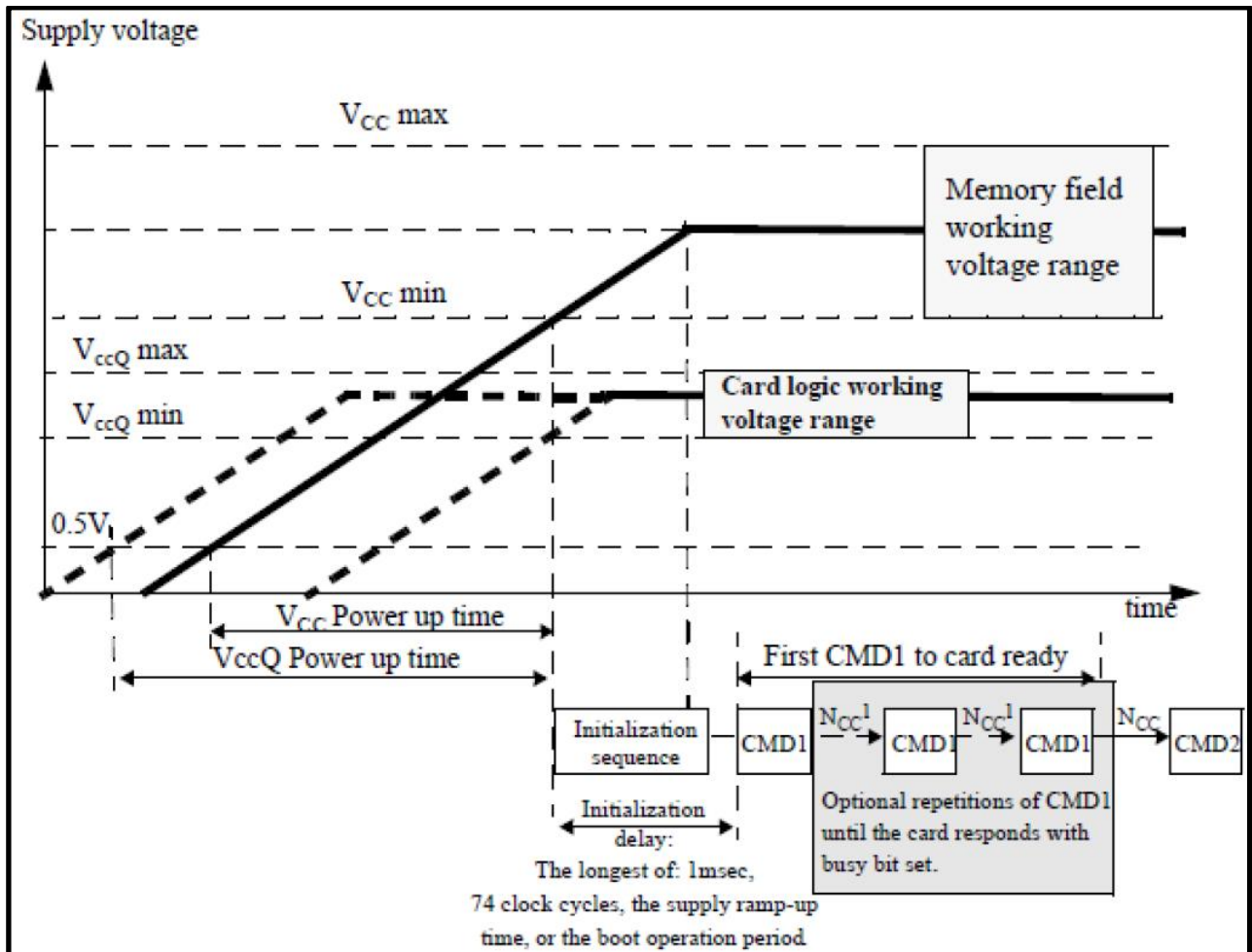

Figure 6.2 eMMC Power-Up Diagram

6.1.2 eMMC Power Cycling

The master can execute any sequence of V_{CC} and V_{CCQ} power-up/power-down. However, the master must not issue any commands until V_{CC} and V_{CCQ} are stable within each operating voltage range. After the slave enters sleep mode, the master can power-down V_{CC} to reduce power consumption. It is necessary for the slave to be ramped up to V_{CC} before the host issues CMD5 (SLEEP_AWAKE) to wake the slave unit. For more information about power cycling see Section 10.1.3 of the JEDEC Standard Specification JESD84-B51.

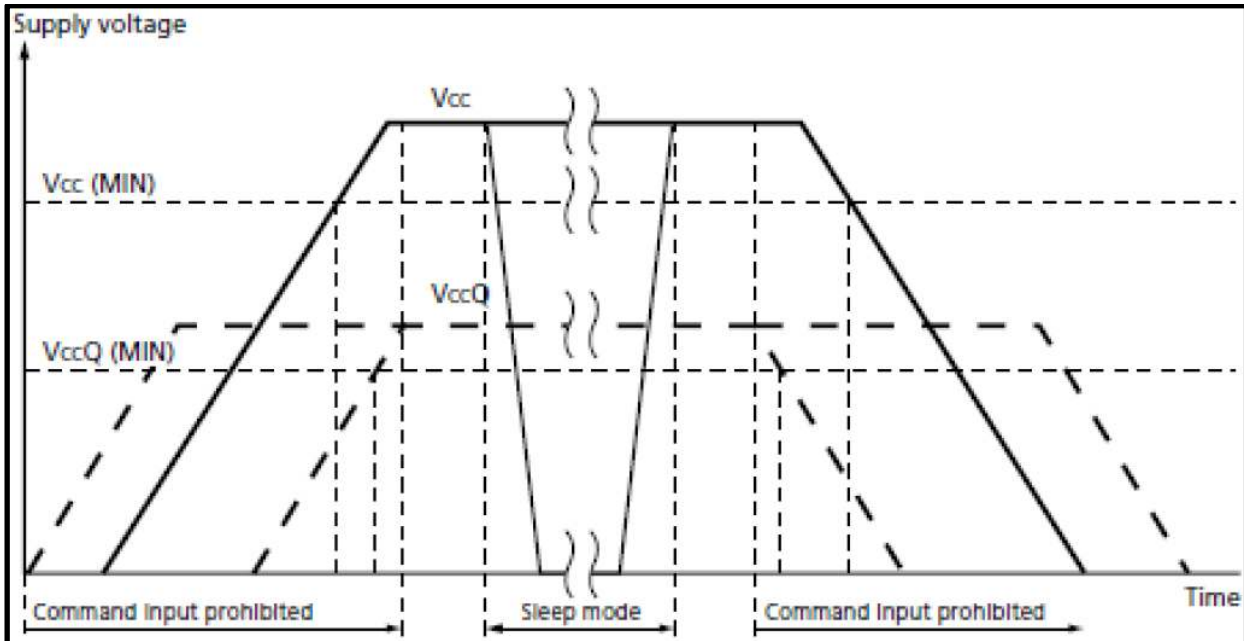

Figure 6.3 – The eMMC Power Cycle

6.2 Bus Operating Conditions

Table 6.1 – General Operating Conditions

Parameter	Symbol	Min	Max.	Unit	Remark
Peak voltage on all lines		-0.5	VCCQ + 0.5	V	
All Inputs					
Input Leakage Current (before initialization sequence and/or the internal pull up resistors connected)		-100	100	μA	
Input Leakage Current (after initialization sequence and the internal pull up resistors disconnected)		-2	2	μA	
All Outputs					
Output Leakage Current (before initialization sequence)		-100	100	μA	
Output Leakage Current (after initialization sequence)		-2	2	μA	

6.2.1 Power supply: eMMC

In the *eMMC*, V_{CC} is used for the NAND flash device and its interface voltage; V_{CCQ} is for the controller and the MMC interface voltage as shown in Figure 8. The core regulator is optional and only required when internal core logic voltage is regulated from V_{CCQ} . A C_{Reg} capacitor must be connected to the V_{DDi} terminal to stabilize regulator output on the system.

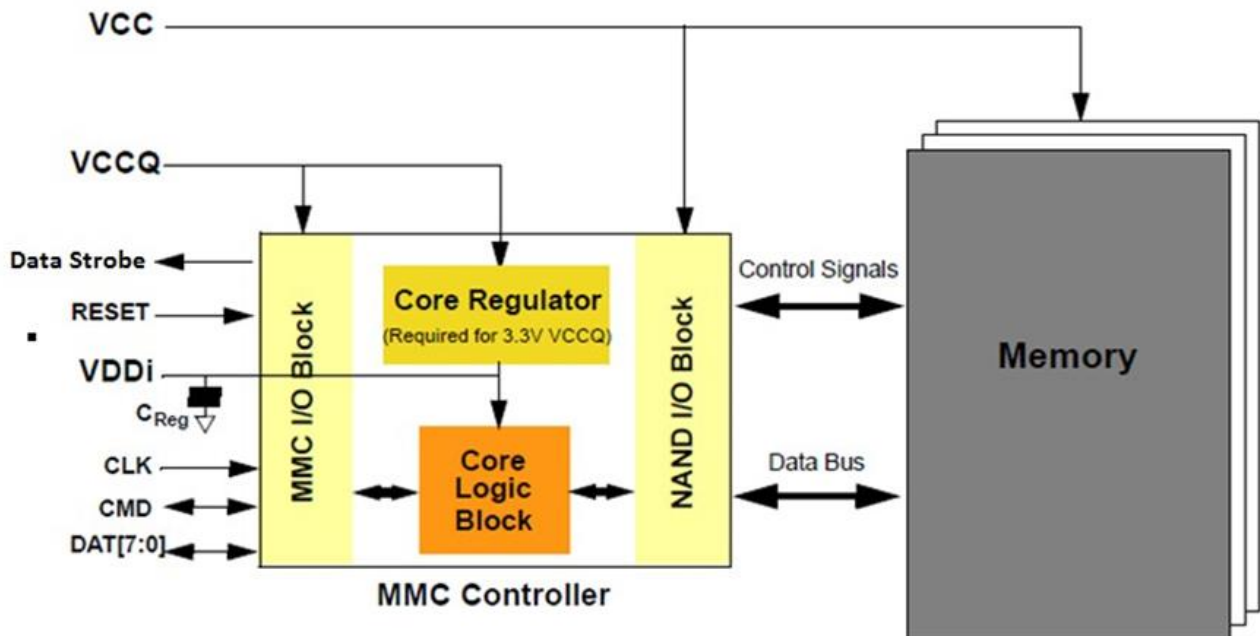
Figure 6.4 – eMMC Internal Power Diagram

6.2.2 eMMC Power Supply Voltage

The *eMMC* supports one or more combinations of V_{CC} and V_{CCQ} as shown in Table 6.2. The V_{CCQ} must be defined at equal to or less than V_{CC} .

Table 6.2 – eMMC Operating Voltage

Parameter	Symbol	MIN	MAX	Unit	Remarks
Supply voltage (NAND)	V_{CC}	2.7	3.6	V	
Supply voltage (I/O)	V_{CCQ}	2.7	3.6	V	
		1.7	1.95	V	
Supply power-up for 3.3V	t_{PRUH}		35	ms	
Supply power-up for 1.8V	t_{PRUL}		25	ms	

The *eMMC* must support at least one of the valid voltage configurations, and can optionally support all valid voltage configurations.

Table 6.3 – eMMC Voltage Combinations

		V_{CCQ}	
		1.7V–1.95V	2.7V–3.6V ⁽¹⁾
V_{CC}	2.7V-3.6V	Valid	Valid

Note:

- V_{CCQ} (I/O) 3.3 volt range is not supported in HS200 /HS400 devices. Also V_{CCQ} (I/O) 3.3 volt range is not supported in automotive A2 Grade device.

6.2.3 Bus Signal Line Load

The total capacitance C_L of each line of the *eMMC* bus is the sum of the bus master capacitance C_{HOST} , the bus capacitance C_{BUS} itself and the capacitance C_{DEVICE} of *eMMC* connected to this line:

$$C_L = C_{HOST} + C_{BUS} + C_{DEVICE}$$

The sum of the host and bus capacitances must be under 20pF.

Table 6.4 – Signal Line Load

Parameter	Symbol	Min	Max	Unit	Remark
Pull-up resistance for CMD	R_{CMD}	4.7	50	Kohm	to prevent bus floating
Pull-up resistance for DAT0–7	R_{DAT}	10	50	Kohm	to prevent bus floating
Bus signal line capacitance	C_L		30	pF	Single Device
Single Device capacitance	C_{DEVICE}		6	pF	
Maximum signal line inductance			16	nH	
V_{CCQ} decoupling capacitor		2.2+0.1	4.7+0.22	μF	It should be located as close as possible to the balls defined in order to minimize connection parasitic
VCC capacitor value		1+0.1	4.7+0.22	μF	It should be located as close as possible to the balls defined in order to minimize connection parasitic
V_{DDI} capacitor value	C_{REG}	1	4.7+0.1	μF	To stabilize regulator output to controller core logics. It should be located as close as possible to the balls defined in order to minimize connection parasitic

6.2.4 HS400 reference load

The circuit in Figure 9 shows the reference load used to define the HS400 Device Output Timings and overshoot / undershoot parameters.

The reference load is made up by the transmission line and the $C_{\text{REFERENCE}}$ capacitance.

The reference load is not intended to be a precise representation of the typical system environment nor a depiction of the actual load presented by a production tester.

System designers should use IBIS or other simulation tools to correlate the reference load to system environment.

Manufacturers should correlate to their production test conditions.

Delay time (t_d) of the transmission line has been introduced to make the reference load independent from the PCB technology and trace length.

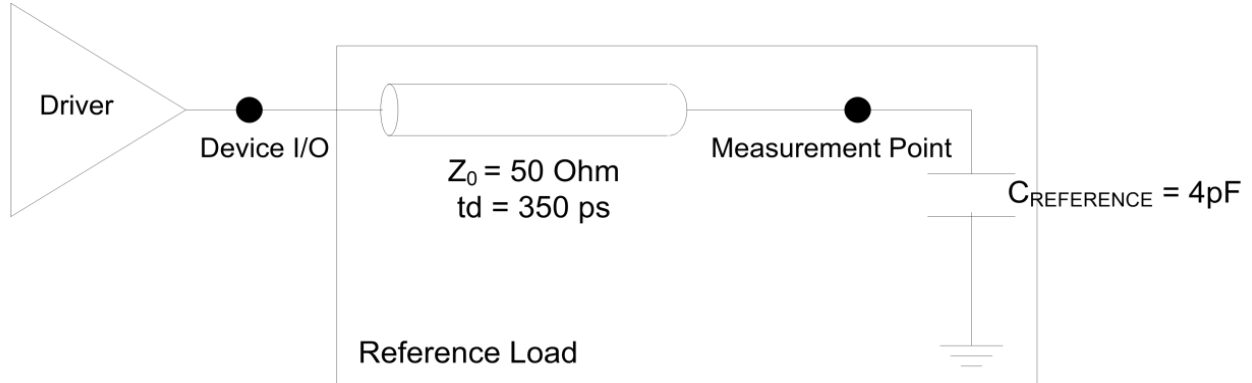

Figure 6.5 – HS400 reference load

6.3 Bus Signal Levels

As the bus can be supplied with a variable supply voltage, all signal levels are related to the supply voltage.

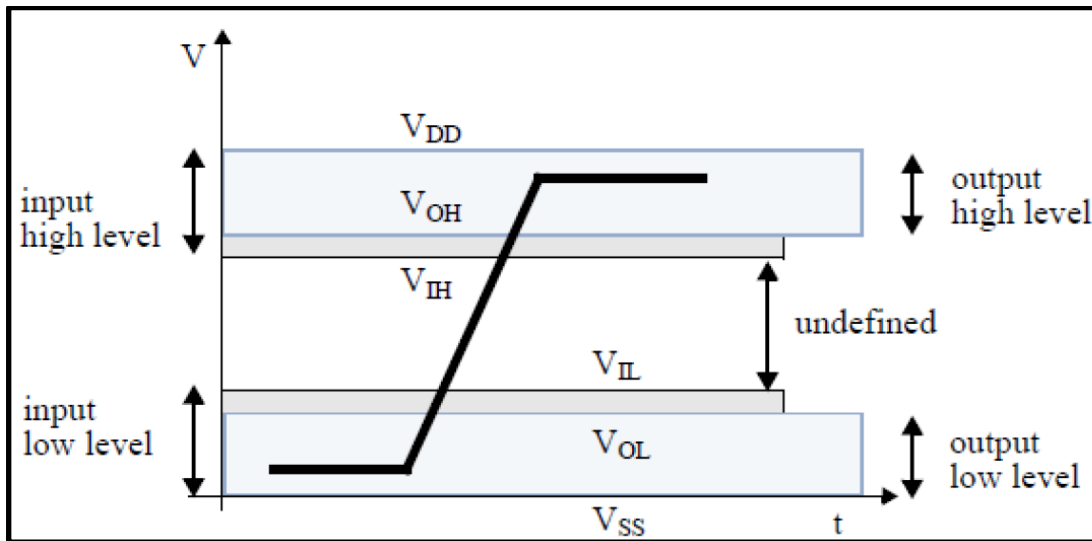

Figure 6.6 – Bus Signal Levels

6.3.1 Open-drain Mode Bus Signal Level

Table 6.5– Open-drain Bus Signal Level

Parameter	Symbol	Min	Max.	Unit	Conditions
Output HIGH voltage	VOH	VDD – 0.2		V	IOH = -100 μ A
Output LOW voltage	VOL		0.3	V	IOL = 2 mA

The input levels are identical with the push-pull mode bus signal levels.

6.3.2 Push-pull mode bus signal level— eMMC

The device input and output voltages shall be within the following specified ranges for any V_{DD} of the allowed voltage range

For 2.7V-3.6V V_{CCQ} range (compatible with JESD8C.01)

Table 6.6 – Push-pull Signal Level—High-voltage eMMC

Parameter	Symbol	Min	Max.	Unit	Conditions
Output HIGH voltage	VOH	0.75 * VCCQ		V	IOH = -100 μ A @ VCCQ min
Output LOW voltage	VOL		0.125 * VCCQ	V	IOL = 100 μ A @ VCCQ min
Input HIGH voltage	VIH	0.625 * VCCQ	VCCQ + 0.3	V	
Input LOW voltage	VIL	VSS – 0.3	0.25 * VCCQ	V	

For 1.70V – 1.95V V_{CCQ} range (: Compatible with EIA/JEDEC Standard “EIA/JESD8-7 Normal Range” as defined in the following table.

Table 6.7 – Push-pull Signal Level—1.70 -1.95 V_{CCQ} Voltage Range

Parameter	Symbol	Min	Max.	Unit	Conditions
Output HIGH voltage	VOH	$V_{CCQ} - 0.45V$		V	IOH = -2mA
Output LOW voltage	VOL		0.45V	V	IOL = 2mA
Input HIGH voltage	VIH	$0.65 * V_{CCQ}^1$	$V_{CCQ} + 0.3$	V	
Input LOW voltage	VIL	$V_{SS} - 0.3$	$0.35 * V_{DD}^2$	V	

Notes:

1. $V_{CCQ} 0.7 * V_{DD}$ for MMC™4.3 and older revisions.
2. $0.3 * V_{DD}$ for MMC™4.3 and older revisions.

Bus Operating Conditions for HS200 & HS400

The bus operating conditions for HS200 devices is the same as specified in sections 10.5.1 of JESD84-B51 through 10.5.2 of JESD84-B51. The only exception is that $V_{CCQ}=3.3v$ is not supported.

6.3.3 Device Output Driver Requirements for HS200 & HS400

Refer to section 10.5.4 of the JEDEC Standard Specification JESD84-B51.

6.4 Bus Timing

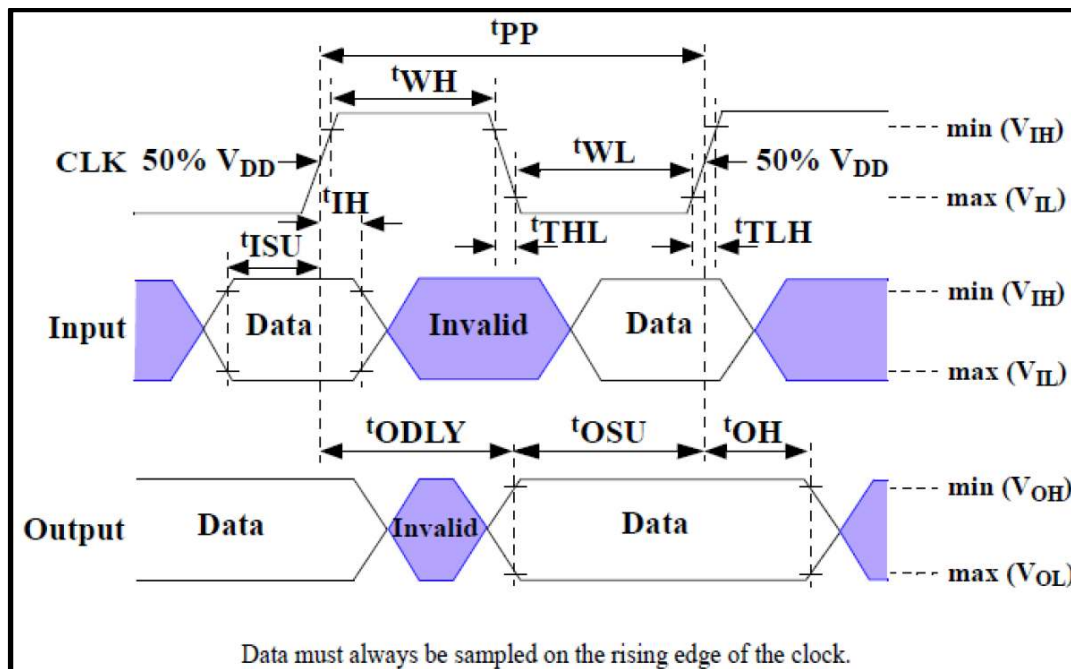

Figure 6.7 – Timing Diagram

6.5 Device Interface Timings

Table 6.8 – High-speed Device Interface Timing

Parameter	Symbol	Min	Max.	Unit	Remark
Clock CLK ⁽¹⁾					
Clock frequency Data Transfer Mode (PP) ⁽²⁾	fPP	0	52 ⁽³⁾	MHz	CL ≤ 30 pF Tolerance: +100KHz
Clock frequency Identification Mode (OD)	fOD	0	400	kHz	Tolerance: +20KHz
Clock high time	tWH	6.5		ns	CL ≤ 30 pF
Clock low time	tWL	6.5		ns	CL ≤ 30 pF
Clock rise time ⁽⁴⁾	tTLH		3	ns	CL ≤ 30 pF
Clock fall time	tTHL		3	ns	CL ≤ 30 pF
Inputs CMD, DAT (referenced to CLK)					
Input set-up time	tISU	3		ns	CL ≤ 30 pF
Input hold time	tIH	3		ns	CL ≤ 30 pF
Outputs CMD, DAT (referenced to CLK)					
Output delay time during data transfer	tODLY		13.7	ns	CL ≤ 30 pF
Output hold time	tOH	2.5		ns	CL ≤ 30 pF
Signal rise time ⁽⁵⁾	tRISE		3	ns	CL ≤ 30 pF
Signal fall time	tFALL		3	ns	CL ≤ 30 pF

Notes:

1. CLK timing is measured at 50% of VDD.
2. eMMC shall support the full frequency range from 0-26Mhz or 0-52MHz
3. Device can operate as high-speed Device interface timing at 26 MHz clock frequency.
4. CLK rise and fall times are measured by min (VIH) and max (VIL).
5. Inputs CMD DAT rise and fall times are measured by min (VIH) and max (VIL) and outputs CMD DAT rise and fall times are measured by min (VOH) and max (VOL).

Table 6.9 – Backward-compatible Device Interface Timing

Parameter	Symbol	Min	Max.	Unit	Remark ⁽¹⁾
Clock CLK ⁽²⁾					
Clock frequency Data Transfer Mode (PP) ⁽³⁾	fPP	0	26	MHz	CL ≤ 30 pF
Clock frequency Identification Mode (OD)	fOD	0	400	kHz	
Clock high time	tWH	10			CL ≤ 30 pF
Clock low time	tWL	10		ns	CL ≤ 30 pF
Clock rise time ⁽⁴⁾	tTLH		10	ns	CL ≤ 30 pF
Clock fall time	tTHL		10	ns	CL ≤ 30 pF
Inputs CMD, DAT (referenced to CLK)					
Input set-up time	tISU	3		ns	CL ≤ 30 pF
Input hold time	tIH	3		ns	CL ≤ 30 pF
Outputs CMD, DAT (referenced to CLK)					
Output set-up time ⁽⁵⁾	tOSU	11.7		ns	CL ≤ 30 pF
Output hold time ⁽⁵⁾	tOH	8.3		ns	CL ≤ 30 pF

Notes:

1. The Device must always start with the backward-compatible interface timing. The timing mode can be switched to high-speed interface timing by the host sending the SWITCH command (CMD6) with the argument for high-speed interface select.
2. CLK timing is measured at 50% of VDD
3. For compatibility with Devices that support the v4.2 standard or earlier, host should not use > 26 MHz before switching to high-speed interface timing.
4. CLK rise and fall times are measured by min (VIH) and max (VIL).
5. tOSU and tOH are defined as values from clock rising edge. However, there may be Devices or devices which utilize clock falling edge to output data in backward compatibility mode. Therefore, it is recommended for hosts either to settWL value as long as possible within the range which will not go over tCK-tOH(min) in the system or to use slow clock frequency, so that host could have data set up margin for those devices. In this case, each device which utilizes clock falling edge might show the correlation either between tWL and tOSU or between tCK and tOSU for the device in its own datasheet as a note.

6.6 Bus Timing for DAT Signals During Dual Data Rate Operation

These timings apply to the DAT[7:0] signals only when the device is configured for dual data mode operation. In this dual data mode, the DAT signals operate synchronously of both the rising and the falling edges of CLK. The CMD signal still operates synchronously of the rising edge of CLK and therefore complies with the bus timing specified in section 10.5, therefore there is no timing change for the CMD signal.

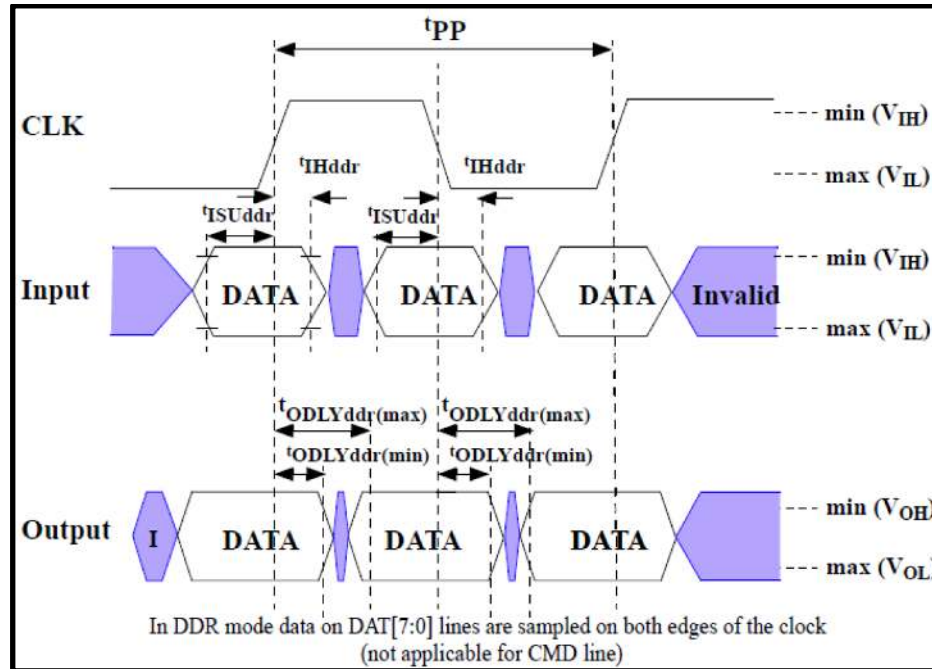

Figure 6.8 – Timing Diagram: Data Input/Output in Dual Data Rate Mode

6.6.1 Dual Data Rate Interface Timings

Table 6.10 – High-speed Dual Data Rate Interface Timing

Parameter	Symbol	Min	Max.	Unit	Remark
Input CLK⁽¹⁾					
Clock duty cycle		45	55	%	Includes jitter, phase noise
Input DAT (referenced to CLK-DDR mode)					
Input set-up time	t _{ISUddr}	2.5		ns	CL ≤ 20 pF
Input hold time	t _{IHddr}	2.5		ns	CL ≤ 20 pF
Output DAT (referenced to CLK-DDR mode)					
Output delay time during data transfer	t _{ODLYddr}	1.5	7	ns	CL ≤ 20 pF
Signal rise time (all signals) ⁽²⁾	t _{RISE}		2	ns	CL ≤ 20 pF
Signal fall time (all signals)	t _{FALL}		2	ns	CL ≤ 20 pF

Notes:

1. CLK timing is measured at 50% of VDD.
2. Inputs CMD, DAT rise and fall times are measured by min (V_{IH}) and max (V_{IL}), and outputs CMD, DAT rise and fall times are measured by min (V_{OH}) and max (V_{OL}).

Bus Timing Specification in HS400 mode

6.6.2 HS400 Device Input Timing

The CMD input timing for HS400 mode is the same as CMD input timing for HS200 mode.

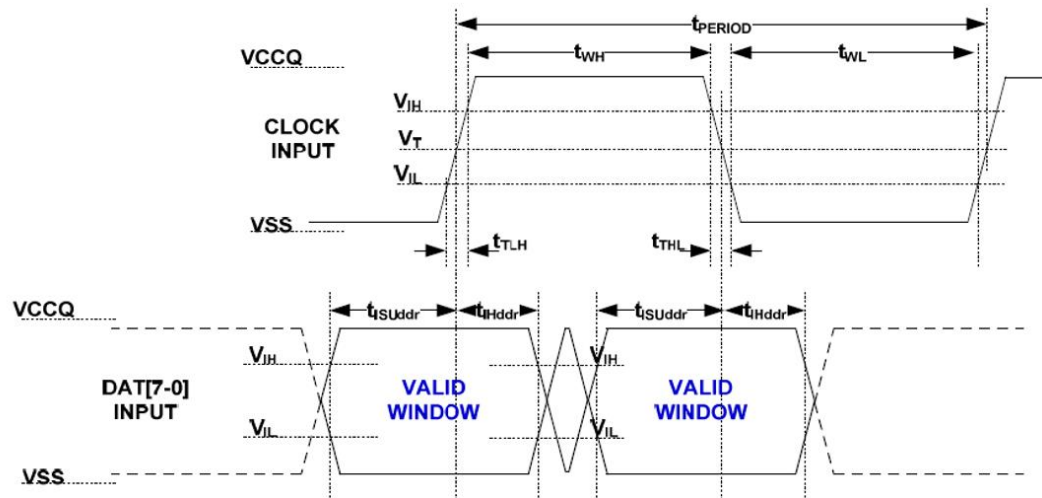

Notes:

1. t_{ISU} and t_{IH} are measured at V_{IL} (max.) and V_{IH} (min.).
2. V_{IH} denotes V_{IH} (min.) and V_{IL} denotes V_{IL} (max.).

Figure 6.9 – HS400 Device Data input timing

Table 6.11 – HS400 Device input timing

Parameter	Symbol	Min	Max	Unit	Remark
Input CLK					
Cycle time data transfer mode	t_{PERIOD}	5			200MHz(Max), between rising edges With respect to V_T .
Slew rate	SR	1.125		V/ns	With respect to V_{IH}/V_{IL} .
Duty cycle distortion	t_{CKDCD}	0.0	0.3	ns	Allowable deviation from an ideal 50% duty cycle. With respect to V_T . Includes jitter, phase noise.
Minimum pulse width	t_{CKMPW}	2.2		ns	With respect to V_T .
Input DAT (referenced to CLK)					
Input set-up time	t_{ISUddr}	0.4		ns	$C_{Device} \leq 6pF$ With respect to V_{IH}/V_{IL} .
Input hold time	t_{IHddr}	0.4		ns	$C_{Device} \leq 6pF$ With respect to V_{IH}/V_{IL} .
Slew rate	SR	1.125		V/ns	With respect to V_{IH}/V_{IL} .

6.6.3 HS400 Device Output Timing

The Data Strobe is used to read data in HS400 mode. The Data Strobe is toggled only during data read or CRC status response.

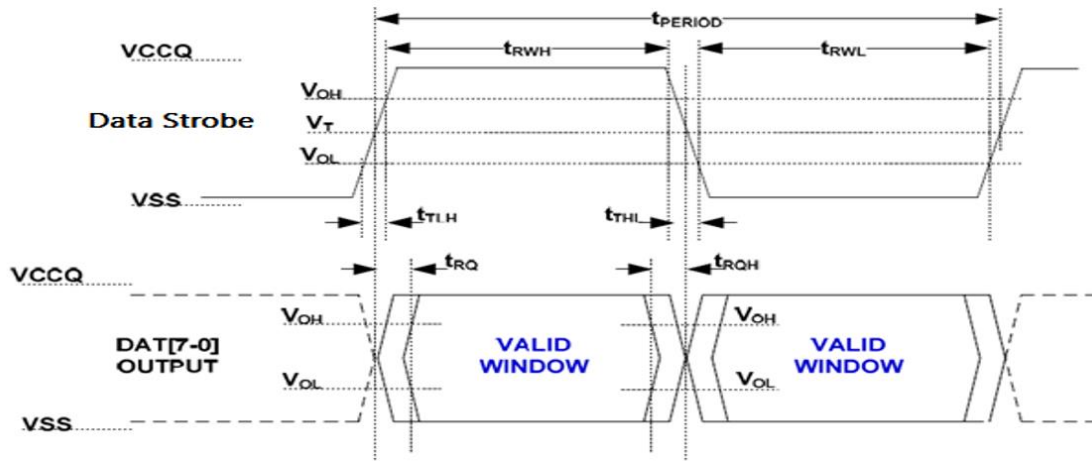

Note:

1. V_{OH} denotes V_{OH} (min.) and V_{OL} denotes V_{OL} (max.).

Figure 6.10 – HS400 Device output timing

Table 6.12 – HS400 Device Output timing

Parameter	Symbol	Min	Max	Unit	Remark
Data Strobe					
Cycle time data transfer mode	tPERIOD	5			200MHz(Max), between rising edges With respect to VT
Slew rate	SR	1.125		V/ns	With respect to VOH/VOL and HS400 reference load
Duty cycle distortion	tDSDCD	0.0	0.2	ns	Allowable deviation from the input CLK duty cycle distortion (tCKDCD) With respect to VT Includes jitter, phase noise
Minimum pulse width	tDSMPW	2.0		ns	With respect to VT
Read pre-amble	tRPRE	0.4	-	tPERIOD	Max value is specified by manufacturer. Value up to infinite is valid
Read post-amble	tRPST	0.4	-	tPERIOD	Max value is specified by manufacturer. Value up to infinite is valid
Output DAT (referenced to Data Strobe)					
Output skew	tRQ		0.4	ns	With respect to VOH/VOL and HS400 reference load
Output hold skew	tRQH		0.4	ns	With respect to VOH/VOL and HS400 reference load.
Slew rate	SR	1.125		V/ns	With respect to VOH/VOL and HS400 reference load

Note:

1. Measured with HS400 reference load

Table 6.13 – HS400 Capacitance

Parameter	Symbol	Min	Max	Unit
Pull-up resistance for CMD	RCMD	4.7	100 ⁽¹⁾	Kohm
Pull-up resistance for DAT0-7	RDAT	10	100 ⁽¹⁾	Kohm
Pull-down resistance for Data Strobe	RDS	10	100 ⁽¹⁾	Kohm
Internal pull up resistance DAT1-DAT7	Rint	10	150	Kohm
Single Device capacitance	CDevice		6	pF

Note:

1. Recommended maximum value is 30 kΩ for 1.2 V and 50 kΩ for 1.8 V interface supply voltages.

7. eMMC Device Overview

The *eMMC* device transfers data via a configurable number of data bus signals. The communication signals are:

7.1 Clock (CLK)

Each cycle of this signal directs a one-bit transfer on the command and either a one bit (1x) or a two bits transfer (2x) on all the data lines. The frequency may vary between zero and the maximum clock frequency.

7.2 Data Strobe

This signal is generated by the device and used for output in HS400 mode. The frequency of this signal follows the frequency of CLK. For data output each cycle of this signal directs two bits transfer(2x) on the data - one bit for positive edge and the other bit for negative edge. For CRC status response output and CMD response output (enabled only HS400 enhanced strobe mode), the CRC status is latched on the positive edge only, and don't care on the negative edge.

7.3 Command (CMD)

This signal is a bidirectional command channel used for Device initialization and transfer of commands. The CMD signal has two operation modes: open-drain for initialization mode, and push-pull for fast command transfer. Commands are sent from the *eMMC* host controller to the *eMMC* Device and responses are sent from the Device to the host.

7.4 Input/Outputs (DAT0-DAT7)

These are bidirectional data channels. The DAT signals operate in push-pull mode. Only the Device or the host is driving these signals at a time. By default, after power up or reset, only DAT0 is used for data transfer. A wider data bus can be configured for data transfer, using either DAT0-DAT3 or DAT0-DAT7, by the *eMMC* host controller. The *eMMC* Device includes internal pull-ups for data lines DAT1-DAT7. Immediately after entering the 4-bit mode, the Device disconnects the internal pull ups of lines DAT1, DAT2, and DAT3. Correspondingly, immediately after entering to the 8-bit mode the Device disconnects the internal pull-ups of lines DAT1–DAT.

Table 5.1 Communication Interface

Name	Type ¹	Description
CLK	I	Clock
DAT0	I/O/PP	Data
DAT1	I/O/PP	Data
DAT2	I/O/PP	Data
DAT3	I/O/PP	Data
DAT4	I/O/PP	Data
DAT5	I/O/PP	Data
DAT6	I/O/PP	Data
DAT7	I/O/PP	Data
CMD	I/O/PP/OD	Command/Response
RST _n	I	Hardware reset
VCC	S	Supply voltage for Core
VCCQ	S	Supply voltage for I/O
VSS	S	Supply voltage ground for Core
VSSQ	S	Supply voltage ground for I/O
DS	O/PP	Data strobe

Note:

1. I: input, O: output, PP: push-pull, OD: open-drain, NC: Not connected (or logical high), S: power supply.

8. eMMC Functional Description

8.1 Pseudo Technology (pSLC)

Each cell in a TLC NAND can be programmed to store 3 bits of data with 8 total voltage states. In Pseudo-SLC mode, the memory cell is used in 1-bit mode, thus resulting in higher endurance, lower error rates and extended temperature range. The firmware optimizes the *eMMC* device with Pseudo technology to achieve industrial and automotive level reliability. For ISSI *eMMC* device, Pseudo SLC (pSLC) mode provides one third capacity of TLC mode.

8.2 Field Firmware Update (FFU)

Field Firmware Updates (FFU) enables features enhancement in the field. Using this mechanism, the host downloads a new version of the firmware to the *eMMC* device and, following a successful download, instructs the *eMMC* device to install the new downloaded firmware into the device.

In order to start the FFU process the host first checks if the *eMMC* device supports FFU capabilities by reading `SUPPPORTED_MODES` and `FW_CONFIG` fields in the `EXT_CSD`. If the *eMMC* device supports the FFU feature the host may start the FFU process. The FFU process starts by switching to FFU Mode in `MODE_CONFIG` field in the `EXT_CSD`. In FFU Mode host should use closed-ended or open ended commands for downloading the new firmware and reading vendor proprietary data. In this mode, the host should set the argument of these commands to be as defined in `FFU_ARG` field. In case these commands have a different argument the device behavior is not defined and the FFU process may fail. The host should set Block Length to be `DATA_SECTOR_SIZE`. Downloaded firmware bundle must be `DATA_SECTOR_SIZE` size aligned (internal padding of the bundle might be required). Once in FFU Mode the host may send the new firmware bundle to the device using one or more write commands.

The host could regain regular functionality of write and read commands by setting `MODE_CONFIG` field in the `EXT_CSD` back to Normal state. Switching out of FFU Mode may abort the firmware download operation. When host switched back to FFU Mode, the host should check the FFU Status to get indication about the number of sectors which were downloaded successfully by reading the `NUMBER_OF_FW_SECTORS_CORRECTLY_PROGRAMMED` in the extended CSD. In case the number of sectors which were downloaded successfully is zero the host should re-start downloading the new firmware bundle from its first sector. In case the number of sectors which were downloaded successfully is positive the host should continue the download from the next sector, which would resume the firmware download operation.

In case `MODE_OPERATION_CODES` field is not supported by the device the host sets to `NORMAL` state and initiates a `CMD0/HW_Reset/Power` cycle to install the new firmware. In such case the device doesn't need to use `NUMBER_OF_FW_SECTORS_CORRECTLY_PROGRAMMED`.

In both cases occurrence of a `CMD0/HW_Reset/Power` occurred before the host successfully downloaded the new firmware bundle to the device may cause the firmware download process to be aborted

8.3 Power Off Notification for Sleep

The host should notify the device before it powers the device off. This allows the device to better prepare itself for being powered off. Power the device off means to turn off all its power supplies. In particular, the host should issue a power off notification (POWER_OFF_LONG, POWER_OFF_SHORT) if it intends to turn off both VCC and VCCQ power or it may use a power off notification (SLEEP_NOTIFICATION) if it intends to turn-off VCC after moving the device to Sleep state.

To indicate to the device that power off notification is supported by the host, a supporting host shall first set the POWER_OFF_NOTIFICATION byte in EXT_CSD [34] to POWERED_ON (0x01). To execute a power off, before powering the device down the host will change the value to either POWER_OFF_SHORT (0x02) or POWER_OFF_LONG (0x03). Host should wait for the busy line to be de-asserted. Once the setting has changed to either 0x02 or 0x03, host may safely power off the device.

The host may issue SLEEP_AWAKE (CMD5) to enter or to exit from Sleep state if POWER_OFF_NOTIFICATION byte is set to POWERED_ON. Before moving to Standby state and then to Sleep state, the host sets POWER_OFF_NOTIFICATION to SLEEP_NOTIFICATION and waits for the DAT0 line de-assertion. While in Sleep (slp) state VCC (Memory supply) may be turned off as defined in 4.1.6. Removing power supplies other than VCC while the device is in the Sleep (slp) state may result in undefined device behavior. Before removing all power supplies, the host should transition the device out of Sleep (slp) state back to Transfer state using CMD5 and CMD7 and then execute a power off notification setting POWER_OFF_NOTIFICATION byte to either POWER_OFF_SHORT or POWER_OFF_LONG.

If host continues to send commands to the device after switching to the power off setting (POWER_OFF_LONG, POWER_OFF_SHORT or SLEEP_NOTIFICATION) or performs HPI during its busy condition, the device shall restore the POWER_OFF_NOTIFICATION byte to POWERED_ON.

If host tries to change POWER_OFF_NOTIFICATION to 0x00 after writing another value there, a SWITCH_ERROR is generated.

The difference between the two power-off modes is how urgent the host wants to turn power off. The device should respond to POWER_OFF_SHORT quickly under the generic CMD6 timeout. If more time is acceptable, POWER_OFF_LONG may be used and the device shall respond to it within the POWER_OFF_LONG_TIME timeout.

While POWER_OFF_NOTIFICATION is set to POWERED_ON, the device expects the host to host shall:

- Keep the device power supplies alive (both VCC and VCCQ) and in their active mode
- Not power off the device intentionally before changing POWER_OFF_NOTIFICATION to either POWER_OFF_LONG or POWER_OFF_SHORT
- Not power off VCC intentionally before changing POWER_OFF_NOTIFICATION to SLEEP_NOTIFICATION and before moving the device to Sleep state

Before moving to Sleep state hosts may set the POWER_OFF_NOTIFICATION byte to SLEEP_NOTIFICATION (0x04) if aware that the device is capable of autonomously initiating background operations for possible performance improvements. Host should wait for the busy line to be de-asserted. Busy line may be asserted up the period defined in SLEEP_NOTIFICATION_TIME byte in EXT_CSD [216]. Once the setting has changed to 0x04 host may set the device into Sleep mode (CMD7+CMD5). After getting out from Sleep the POWER_OFF_NOTIFICATION byte will restore its value to POWERED_ON. HPI may interrupt the SLEEP_NOTIFICATION operation. In that case POWER_OFF_NOTIFICATION byte will restore to POWERED_ON.

8.4 Enhanced User Data Area

ISSI *eMMC* supports Enhanced User Data Area feature which allows the User Data Area of *eMMC* to be configured as SLC Mode. Therefore, when host set the Enhanced User Data Area, the area will occupy more size of original set up size. The Max Enhanced User Data Area size is defined as - (MAX_ENH_SIZE_MULT x HC_WP_GRP_SIZE x HC_ERASE_GRP_SIZE x 512 KBytes). The Enhanced use data area size is defined as - (ENH_SIZE_MULT x HC_WP_GRP_SIZE x HC_ERASE_GRP_SIZE x 512 KBytes). The host shall follow the flow chart of JEDEC spec for configuring the parameters of General Purpose Area Partitions and Enhanced User Data Area.

8.5 Write Cache

Cache is a temporary storage space in an *eMMC* device. The cache should in typical case reduce the access time and increase the speed (compared to an access to the main nonvolatile storage). The cache is not directly accessible by the host. This temporary storage space may be utilized also for some implementation specific operations like as an execution memory for the memory controller and/or as storage for an address mapping table etc. However, there is data inconsistency risk when using nonvolatile cache. It's recommend only turning on the cache for the application which requires not too high reliability.

The cache shall be OFF by default after power up, RST_n assertion or CMD0. All accesses shall be directed to the nonvolatile storage like defined elsewhere in this specification. The cache function can be turned ON and OFF by writing to the CACHE_CTRL byte (EXT_CSD byte [33]). Turning the cache ON shall enable behavior model defined in this section. Turning the cache OFF shall trigger flushing of the data to the nonvolatile storages

8.6 Cache Enhancement Barrier

Barrier function provides a way to perform a delayed in-order flushing of a cached data. The main motivation for using barrier commands is to avoid the long delay that is introduced by flush commands. There are cases where the host is not interested in flushing the data right away, however it would like to keep an order between different cached data batches. The barrier command enables the host achieving the in-order goal but without paying the flush delay, since the real flushing can be delayed by the device to some later idle time. The formal definition of the barrier rule is as follows:

Denote a sequence of requests R_i , $i=0,..,N$. Assuming a barrier is set between requests R_x and R_{x+1} ($0 < x < N$) then all the requests $R_0..R_x$ must be flushed to the non-volatile memory before any of the requests $R_{x+1}..R_N$.

Between two barriers the device is free to write data into the non-volatile memory in any order. If the host wants to preserve a certain order it shall flush the cache or set another barrier at a point where order is important.

The barrier is set by writing to the BARRIER bit of the FLUSH_CACHE byte (EXT_CSD byte [32]). Any error resulted can be read from the status register by CMD13 after the completion of the programming as defined for a normal write request. The error could affect any data written to the cache since the previous flush operation.

The device shall support any number of barrier commands between two flush commands. In case of multiple barrier commands between two flush commands a subset of the cached data may be committed to the non-volatile memory according to the barrier rule. Internally, a device may have an upper limit on the barrier amount it can absorb without flushing the cache. That is, if the host exceeds this barrier amount, the device may issue, internally, a normal flush.

The device shall expose its barrier support capability via the BARRIER_SUPPORT byte (EXT_CSD byte [486]). If a device does not support barrier function this register shall be zero. If a device supports barrier function this register shall be one.

Assuming the device supports barrier function, if the BARRIER bit of the FLUSH_CACHE byte is set, a barrier operation shall be executed.

If the cache gets totally full and/or the cache is not able to receive the data of the next access (per block count indicated in CMD23 or per initiated single / open ended multiple block write in general) then it shall still be the responsibility of the *eMMC* device to store the data of the next access within the timeouts that are specified elsewhere in this specification. The actual algorithm to handle the new data and possible flush of some older cached data is left for the implementation.

Note: When issuing a force-programming write request (CMD23 with bit 24 on) or a reliable write request (CMD23 with bit 31 on), the host should be aware that the data will be written to the non-volatile memory, potentially, before any cached data, even if a barrier command was issued. Therefore, if the writing order to the non-volatile memory is important, it is the responsibility of the host to issue a flush command before the force-programming or the reliable-write request.

In order to use the barrier function, the host shall set bit 0 of BARRIER_EN (EXT_CSD byte [31]). The barrier feature is optional for an *eMMC* device.

8.7 Cache Flushing Policy

The host may require the device to flush data from the cache in an in-order manner. From time to time, to guarantee in-order flushing, the host may command the device to flush the device cache or may use a barrier command.

However, if the *eMMC* device flushing policy is to flush data from the cache in an in-order manner, cache barrier commands or flush commands operations (In case goal is to guarantee the flushing order) are redundant and impose a needless overhead to the device and host.

FIFO bit in CACHE_FLUSH_POLICY field (EXT_CSD byte [240]) is used by the device to indicate to the host that the device cache flushing policy is First-In-First-Out; this means that the device guarantees that the order of the flushing of data would be the in same order which data was written to the cache. When the FIFO bit is set it is recommended for the host not to send cache barrier commands or flush operations which goal is to guarantee the flushing order as they are redundant and impose a burden to the system.

However, if the FIFO bit is set to 1b and the device supports the cache barrier mechanism, the host may still send barrier commands without getting an error. Sending these commands will not change the device behavior as device flushes cache in-order anyway.

The CACHE_FLUSH_POLICY field is read-only field and never change its value either by the host or device.

8.8 Command Queuing (Disable by default)

To facilitate command queuing in *eMMC*, the device manages an internal task queue to which the host can queue data transfer tasks.

Initially the task queue is empty. Every task is issued by the host and initially queued as pending. The device controller works to prepare pending tasks for execution. When a task is ready for execution its state changes to “ready for execution”. The exact meaning of “ready for execution” is left for device implementation.

The host tracks the state of all queued tasks and may order the execution of any task, which is marked as “ready for execution” by sending a command indicating its task ID. When the execute command is received (CMD46/CMD47) the device executes the data transfer transaction.

For example, in order to queue a write transaction, the host sends a CMD44 indicating the task’s parameters. The device responds and the host sends a CMD45, indicating the start block address.

The device regards the two commands as a single task in the queue and sends a response indicating success if no error is detected. This exchange may be executed on the CMD line while a data transfer, or busy state, is ongoing on the DAT lines. The host tracks the state of the queue using CMD13.

At a later time, when data transfer is not in progress, the host issues a CMD47, ordering the device to execute a task from the queue, providing the Task ID in its argument. The device responds with an R1 response and the data transfer starts.

Note that if hosts need to access RPMB partition, the host should disable the Command Queue mechanism and access RPMB partition not through the command queue.

General Purpose partitions may be accessed when command queuing is enabled.

The queue must be empty when CMD6 is sent (to switch partitions or to disable command queuing).

Sending CMD6 while the queue is not empty shall be regarded as illegal command (as explained 6.6.42.9 Supported Commands).

Prior to enabling command queuing, the block size shall be set to 512B. Device may respond with an error to CMD46/CMD47 if block size is not 512B.

8.9 Production State Awareness (PSA)

eMMC device could utilize the information of whether it is in production environment and operate differently than it operates in the field.

For example, content that was loaded into the storage device prior to soldering might get corrupted, at higher probability, during device soldering. The *eMMC* device could use “special” internal operations for loading content prior to device soldering that would reduce production failures and use “regular” operations post-soldering.

PRODUCTION_STATE_AWARENESS [133] field in extended CSD is used as a mechanism through which the host should report to the device whether it is pre or post soldering state.

This standard defines two methods, Manual Mode and Auto Mode, to manage the device production state.

The trigger for starting or re-starting the process is setting correctly PRE_LOADING_DATA_SIZE field. Before setting this field the host is expected to make sure that the device is clean and any data that was written before to the device is expected to be erased using CMD35, CMD36 and CMD38.

In case the host erased data, overrode existing data or performed re-partition during production state awareness it should restart the production state awareness process by re-setting PRE_LOADING_DATA_SIZE.

9. PACKAGE TYPE INFORMATION

100-ball FBGA Package (Q)

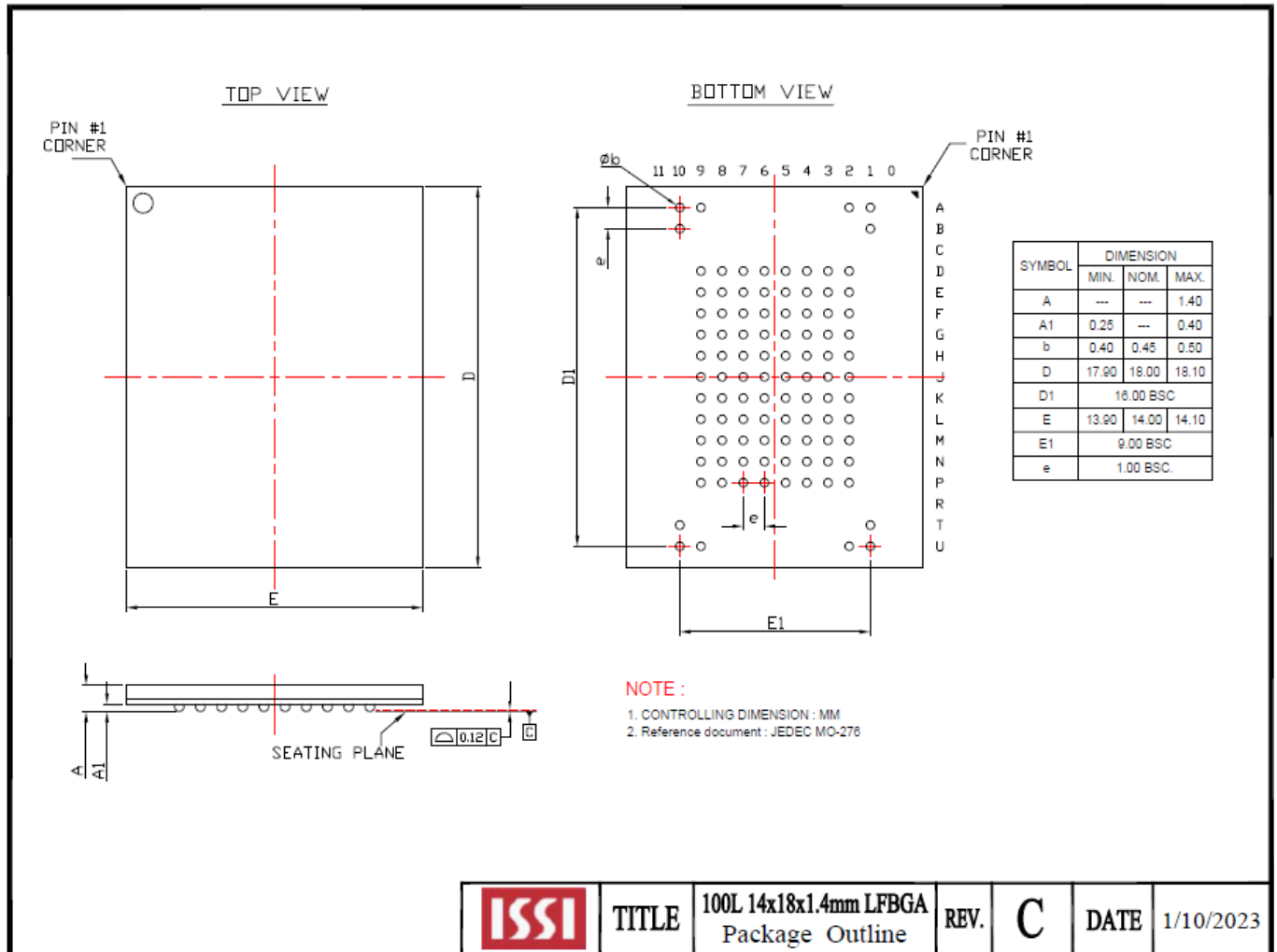

153-BALL FBGA Package (C)

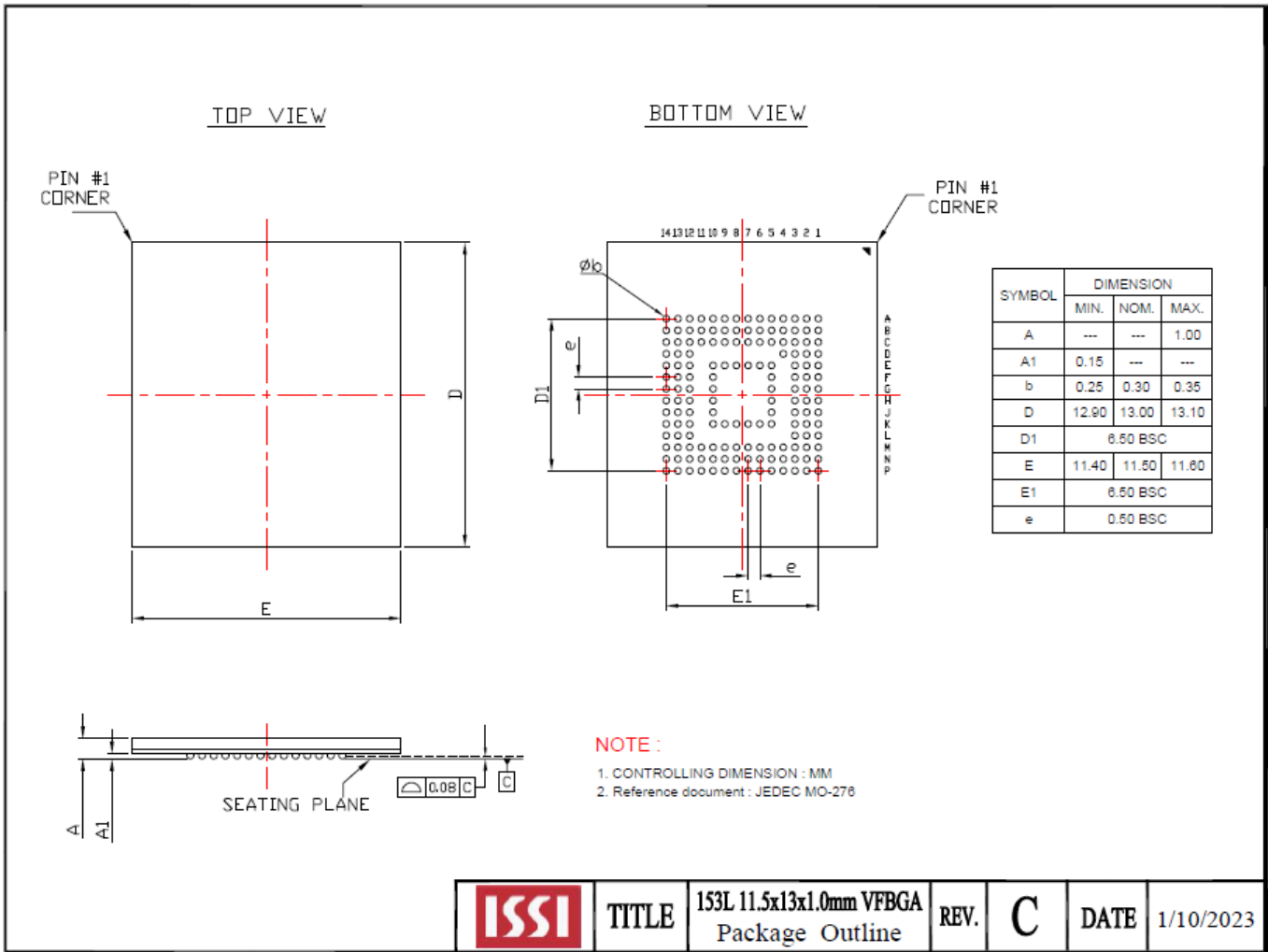

10. ORDERING INFORMATION – Valid Part Numbers

IS 22 T F 08G _ - J C L A2

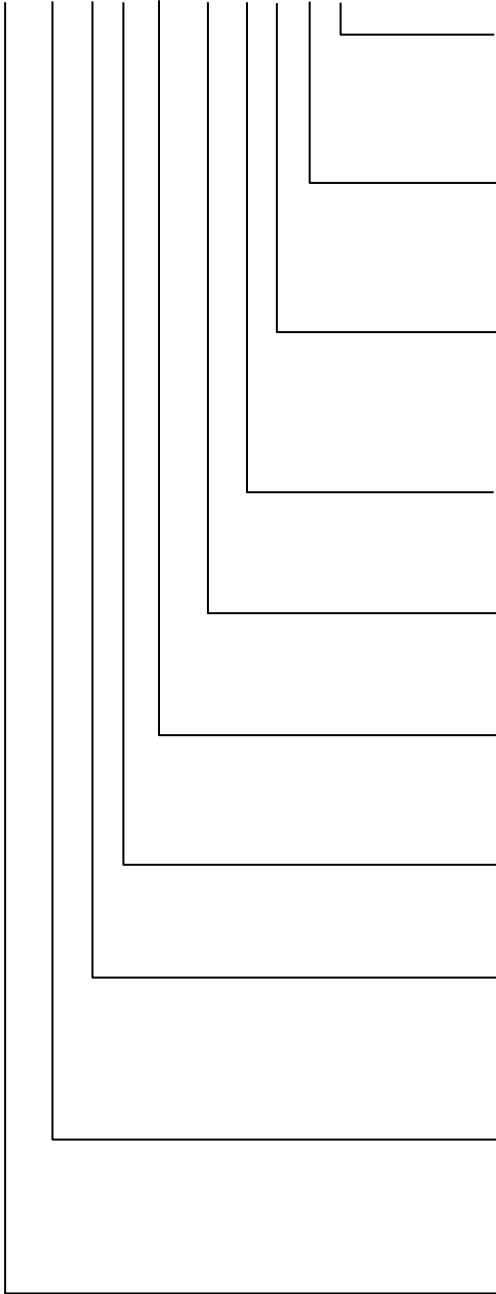

TEMPERATURE RANGE

I = Industrial Grade (-40°C to +85°C) (Call Factory)
 A1 = Automotive Grade (-40°C to +85°C)
 A2 = Automotive Grade (-40°C to +105°C)

PACKAGING CONTENT

L = RoHS compliant

PACKAGE Type

C = 153-ball FBGA
 Q = 100-ball FBGA

OPTION

J = Standard (Boot Partition Size: 4MB)
 B = Boot Partition Size: 16MB

Generation.

Blank = 1st Gen.

eMMC Density

08G = 8 GB

INTERFACE

F = eMMC 5.1

Flash Cell Technology

T = ISSI eMMC with TLC NAND

Product Family

21 = Managed NAND
 22 = Automotive Managed NAND

BASE PART NUMBER

IS = Integrated Silicon Solution Inc.



Density	Interface	Package	Temp. Grade	Order Part Number
8GB	eMMC 5.1	100 FBGA	Automotive, A1 ⁽¹⁾	IS22TF08G-JQLA1
				IS22TF08G-BQLA1
		153 FBGA	Automotive, A1 ⁽¹⁾	IS22TF08G-JCLA1
				IS22TF08G-BCLA1
			Automotive, A2 ⁽¹⁾	IS22TF08G-JCLA2
				IS22TF08G-BCLA2

Note:

1. A1, A2: Meets AEC-Q100 requirements with PPAP.