

**Description**

Single pole, DIN rail mount, hydraulic-magnetic miniature circuit breaker (MCB) in accordance with UL1077, CSA22.2, and UL Class I Division 2, Groups A, B, C, D.

**Typical Applications**

Hazardous locations where flammable liquids, gases, vapors, or combustible dust exists in sufficient quantities to produce an explosion or fire. Typical applications include; Oil & Gas drilling and production, Agricultural processing and storage, and Saw Mill / Pulp & Paper production.

**Ordering Information**

<b>Type No.</b>	
4231	Hydraulic-magnetic high performance circuit breaker
<b>Mounting</b>	
T1	Rail mounting
<b>Number of poles</b>	
1	Single pole protected
<b>Accessories</b>	
0	Without
<b>Terminals</b>	
K0	Screw terminals
<b>Characteristic curve</b>	
F1	DC short time delay*
F2	AC short time delay
<b>Approvals</b>	
H	UL1077, CSA22.2, UL Class I Division 2
<b>Current ratings</b>	
1, 2, 3, 5, 7, 8, 10, 12, 15, (20A)**	

4231 - T1 1 0 - K0 F2 H - 10A ordering example  
 \* Visit [www.e-t-a.com/us\\_esx10-t/](http://www.e-t-a.com/us_esx10-t/) to see ESX10 Electronic Breakers for 24VDC Class I Division II applications  
 \*\* for 50VDC only

**Available product configurations**

Part number	Current rating	Description
4231-T110-K0F1H- 4231-T110-K0F2H-	1A	UL1077, CID2, 1P, 120VAC, 50VDC
	2A	
	3A	
	5A	
	7A	
	8A	
	10A	
	12A	
	15A	UL1077, CID2, 1P, 50VDC
	20A	

**Approvals**

Authority	Standard	Rated voltage	Current ratings
UL	Class I Div 2 GP A, B, C, D ISA 12.12.01-2015 CSA C22.2 No. 213	120VAC 50/60 Hz 50VDC	1, 2, 3, 5, 7, 8, 10, 12, 15, 20A*
UL	UL 1077 CSA C22.2 No. 235-04		

\* for 50VDC only



**Technical Data**

Voltage rating	120VAC, 50VDC
Current rating range	1... 15A (AC) 1... 20A (DC)
Interrupting capacity	1000 A (AC and DC)
Temperature	-40° - 65°C
Ambient typical life	1... 20A 6000 operations @ 1 x I <sub>N</sub>
Insulation Resistance	>100 mega ohms (100VDC)
Dielectric Strength	1250 V RMS, 60 Hz (between terminals)
Degree of Protection	IP20
<b>Vibration</b>	
Directions 1, 2, 3, 4:	5 g at 1.0 x I <sub>N</sub>
Directors 5, 6:	10 g at 1.0 x I <sub>N</sub> (57-2000 Hz) +/- 0.76 mm (10-57 Hz) to IEC 60068-2-6, test Fc 10 frequency cycles/axis
<b>Shock</b>	
Directions 2, 3, 4, 5, 6:	40 g/11 ms/half sine at 1.0 x I <sub>N</sub>
Direction 1:	30 g/11 ms/half sine at 1.0 x I <sub>N</sub> to IEC 60068-2-27, test Ea
<b>Humidity</b>	240 hrs in 95% RH, temperature 40 Deg C test to IEC60068-2-78, test Cab
<b>Corrosion</b>	96 hrs in 5% salt mist test to IEC60068-2-11, test Ka

**Schematic Diagram**

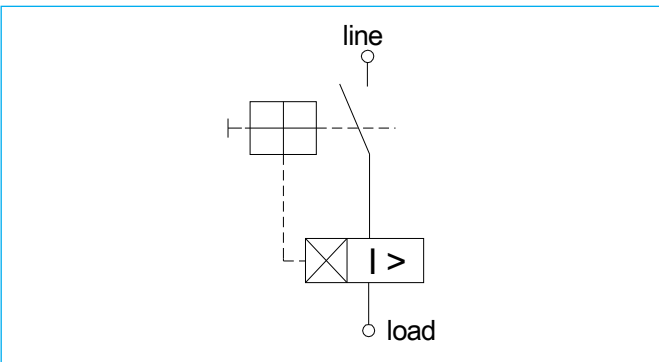

## Time/current characteristic

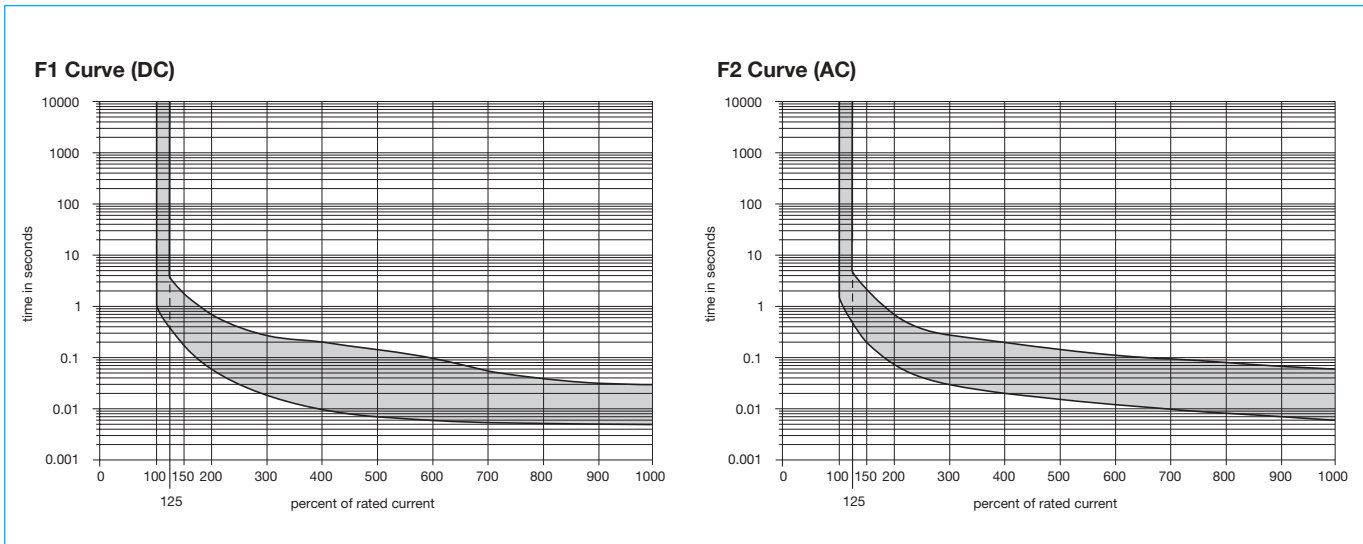

## Dimensions

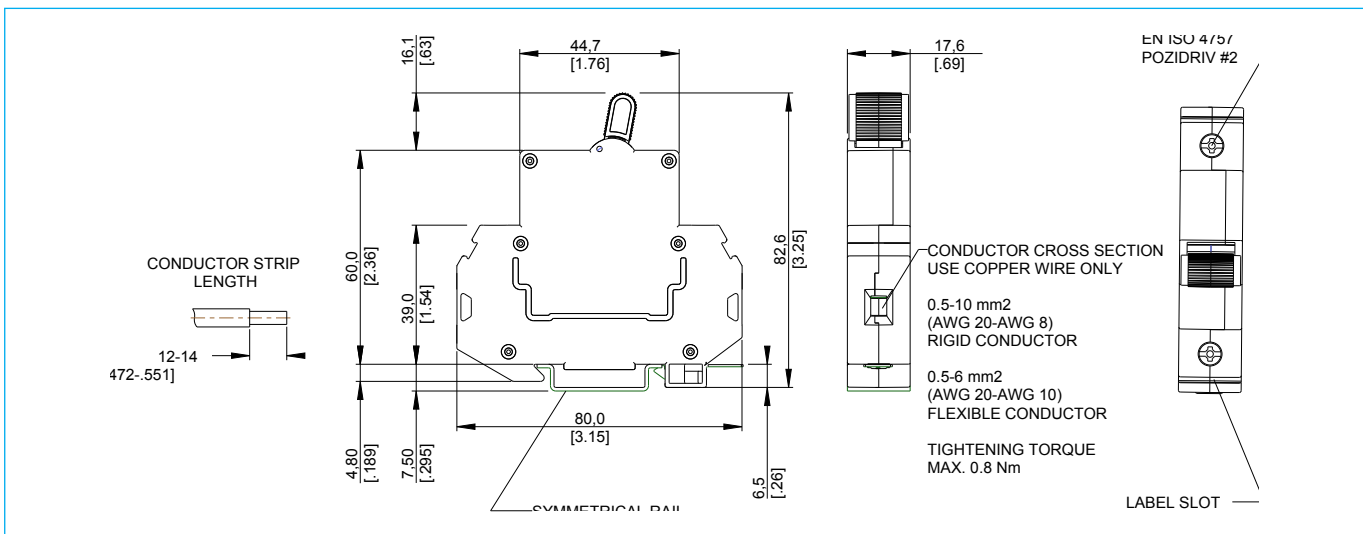

## Temperature Derating Factor

Ambient Temperature	Temperature rating of conductor	
	75°C	90°C
40°C	1.00	1.00
50°C	1.00	1.00
60°C	0.80	1.00
65°C	0.70	0.80

## Shock directions

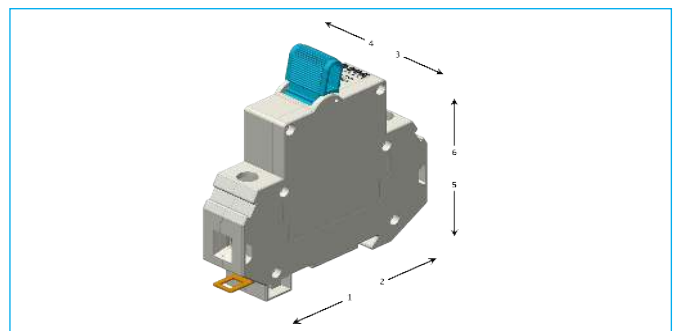

## Approval Details

Model	File Number	Type	UG	FW	U(V)	I(A)	TC	OL	SC
4231	E67320, E498433	OC	A	0	120 VAC	1... 15A	1	1	C1, 1KA*
					50 VDC	1... 20A			U1, 1KA

\*Evaluated with series fuse RK5 rated no more than 4X the rating of the protector