

Tous droits strictement réservés. Reproduction ou communication à des tiers interdite, sous quelque forme que ce soit sans autorisation écrite du propriétaire. Propriété de c.FCI. Droits de reproduction FCI.

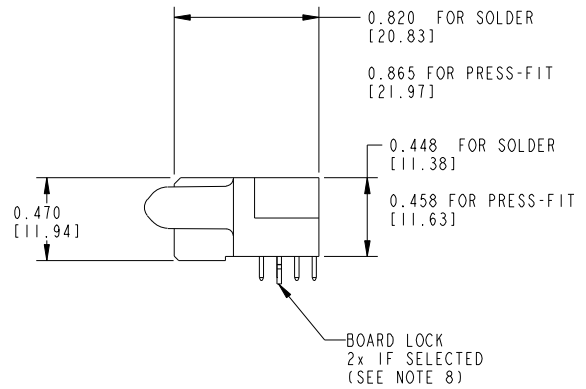

All rights strictly reserved. Reproduction or issue to third parties in any form whatever is not permitted without written authority from the proprietor. Property of FCI. Copyright FCI.

PRODUCT NUMBER
51762- ABBCCC00EF--
Note: ③
SEE NOTE 1

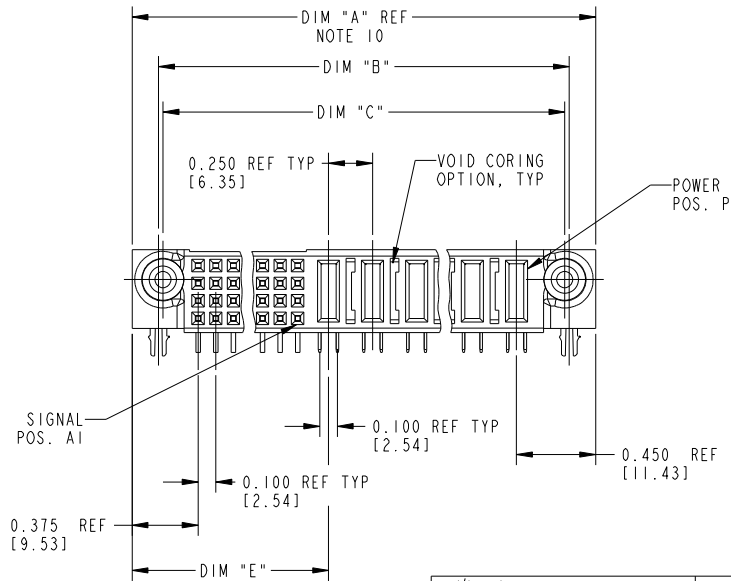
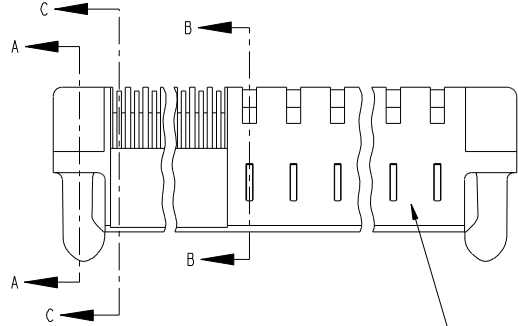

mat'l code SEE NOTE 2				tolerances unless otherwise specified		CUSTOMER COPY		FCI www.fciconnect.com	
ltr	ecn no.	dr	date	linear	.XX±.01/.X±.3	projection		title RIGHT ANGLE RECEPTACLE w/GUIDE PIN POWER / SIGNAL	
J	0605-0124	SJ	06/03/05	angles	.XXX±.005/.XX±.13	INCH / MM		product family PWRBLADE	code 213
K	0608-0239	JC	09/11/08	dr	.XXX±.0020/.XX±.051	scale 1:1	size A	dwg no 51762	SHEET 1 OF 3
				enr	0°±2°				
				chr	D.BOGLE 05-18-99				
				appd	J. BROWN 05-18-99				
					J. BROWN 05-18-99				
sheet index	revision sheet	K 1	K 2	K 3					

THIS FILE WAS ORIGINALLY CREATED IN THE PRO ENGINEER ENVIRONMENT AND ANY FUTURE REVISIONS TO THIS FILE MUST BE MADE IN THE PRO ENGINEER ENVIRONMENT

form no. 7530-001-103

cage code 22526

Tous droits strictement réservés. Reproduction ou communication à des tiers interdite, sous quelque forme que ce soit sans autorisation écrite du propriétaire. Propriété de c.FCI. Droits de reproduction FCI.



All rights strictly reserved. Reproduction or issue to third parties in any form whatever is not permitted without written authority from the proprietor. Property of FCI. Copyright FCI.

PRODUCT NUMBER
51762-ABBCC00EF-- Note: ③
SEE NOTE 1

DIM	LENGTH FORMULAS (SEE NOTE 10)
DIM "A"	.100 [2.54] x (CCC/4) + .250 [6.35] x BB + .650 [16.51] (NOTE 10)
DIM "B"	.100 [2.54] x (CCC/4) + .250 [6.35] x BB + .350 [8.89]
DIM "C"	.100 [2.54] x (CCC/4) + .250 [6.35] x BB + .300 [7.62]
DIM "E"	.100 [2.54] x (CCC/4) + .450 [11.43]
DIM "F"	.100 [2.54] x (CCC/4) + .250 [6.35] x BB + .680 [17.27]
DIM "H"	.100 [2.54] x (CCC/4) + .250 [6.35]

CONNECTOR NOTES

- ① PRODUCT NUMBER CODE:
51762 - A BB CCC 00 E F LF
- NO THIS SUFFIX: 100u"/2.54um SnPb ON PCB INTERFACE
 - ADD THIS SUFFIX: 78u"/2.00um Sn ON PCB INTERFACE
 - RETENTION TO PCB (NOTE 8)
 - TAIL OPTIONS (NOTE 7)
 - ALWAYS '00' (ZERO,ZERO) (NOTE 6)
 - NUMBER OF SIGNAL CONTACTS (NOTE 5)
 - NUMBER OF RIGHT POWER CONTACTS (NOTE 4)
 - PLATING (NOTE 3)
 - BASE NUMBER

- ② HOUSING MATERIAL: GLASS FILLED V-O HIGH TEMP THERMO PLASTIC.
SIGNAL CONTACT MATERIAL: COPPER ALLOY
POWER CONTACT MATERIAL: COPPER ALLOY
- ③ PLATING OPTION:
I = SEE PRINT 10064183 FOR PLATING SPEC OF 51762-1BCC00EF; 51762-1BCC00EFLF
- ④ RIGHT END POWER CONTACTS, 01 TO 19 AVAILABLE.
MAXIMUM OF 20 POWER CONTACTS PER CONNECTOR
- ⑤ SIGNAL CONTACTS, 004 TO 148 AVAILABLE FOR SOLDER TO BOARD.
020 TO 148 AVAILABLE FOR PRESS-FIT TO BOARD.
- ⑥ THIS PART NOT AVAILABLE WITH LEFT SIDE POWER CONTACTS.
- ⑦ TAIL OPTIONS:
A = .135 ± .010 [3.43 ± .25] SOLDER TO BOARD
B = .090 ± .005 / -.010 [2.29 ± 0.13 / -.25] SOLDER TO BOARD
C = .154 ± .010 [3.91 ± 0.25] PRESS-FIT TO BOARD

- ⑧ RETENTION TO PCB OPTIONS:
A = BOARD LOCK (REQUIRES .098 ± .002 / -.001 [2.49 ± 0.05 / -0.03] THRU HOLE IN PCB MOUNTING FOOT HEIGHT: .220 [5.59])
NOT AVAILABLE FOR PRESS-FIT
B = .150 [3.81] THRU HOLE (REQUIRES .158 ± 0.003 [4.01 ± 0.08] THRU HOLE IN PCB). MOUNTING FOOT HEIGHT: .160 [4.06])
ALWAYS AVAILABLE FOR PRESS-FIT
- ⑨ MANUFACTURE'S NAME, P/N, AND DATE CODE TO APPEAR ON THIS SURFACE.
- ⑩ THE MAXIMUM OVERALL LENGTH (DIM A) OF A PART IS 8.00 [203.2]
11. PRODUCT SPECIFICATION GS-12-149
12. APPLICATION SPECIFICATION BUS-20-067.
13. FOR PRESS-FIT CONNECTORS USE FCI CAM TOOL 430140-XXX TO APPLY CONNECTOR TO PCB.
- PCB NOTES:
14. ALL DIMENSIONS ARE BASIC UNLESS OTHERWISE SPECIFIED.
15. ALL THROUGH HOLES ARE LOCATED WITH A TRUE POSITION OF .004 [0.10]
16. ALL HOLE DIAMETERS ARE FINISHED HOLE SIZE.
- ⑬ ∅ 0.0453 ± .001 [1.151 ± 0.02] DRILLED HOLES PLATED WITH 0.0003 [0.007] MIN SnPb OVER 0.001 [1.03] TO .003 [0.08] PLATING TO ACHIEVE A .040 ± .003 [1.02 ± 0.08] HOLE.
18. A Δ SYMBOL WILL BE NEXT TO ANY DIMENSION, VIEW, OR NOTE WHICH HAS BEEN MODIFIED WITH THE CURRENT DRAWING REVISION.

THIS FILE WAS ORIGINALLY CREATED IN THE PRO ENGINEER ENVIRONMENT AND ANY FUTURE REVISIONS TO THIS FILE MUST BE MADE IN THE PRO ENGINEER ENVIRONMENT

mat'l code				tolerances unless otherwise specified		CUSTOMER COPY		FCI www.fciconnect.com	
ltr	ecr no.	dr	date	linear	.XX±.01 / .X±.3	projection	title	RIGHT ANGLE RECEPTACLE w/GUIDE PIN POWER / SIGNAL	
k					.XXX±.005 / .XXX±.13			INCH / MM	product family
				angles	.XXX±.0020 / .XXX±.051	scale	size		
				dr	0° ± 2°			1:1	A
				enr	DBOGLE 05-18-99	sheet index	revision sheet		
				chr	J. BROWN 05-18-99			cage code	
				appd	J. BROWN 05-18-99				

form no. 7530-001-103

1 2

3

cage code 22526

4

Tous droits strictement réservés. Reproduction ou communication à des tiers interdite, sous quelque forme que ce soit sans autorisation écrite du propriétaire. Propriété de c.FCI. Droits de reproduction FCI.



All rights strictly reserved. Reproduction or issue to third parties in any form whatever is not permitted without written authority from the proprietor. Property of FCI. Copyright FCI.

PRODUCT NUMBER
51762-ABBCCC00EF__
Note: ③
SEE NOTE 1

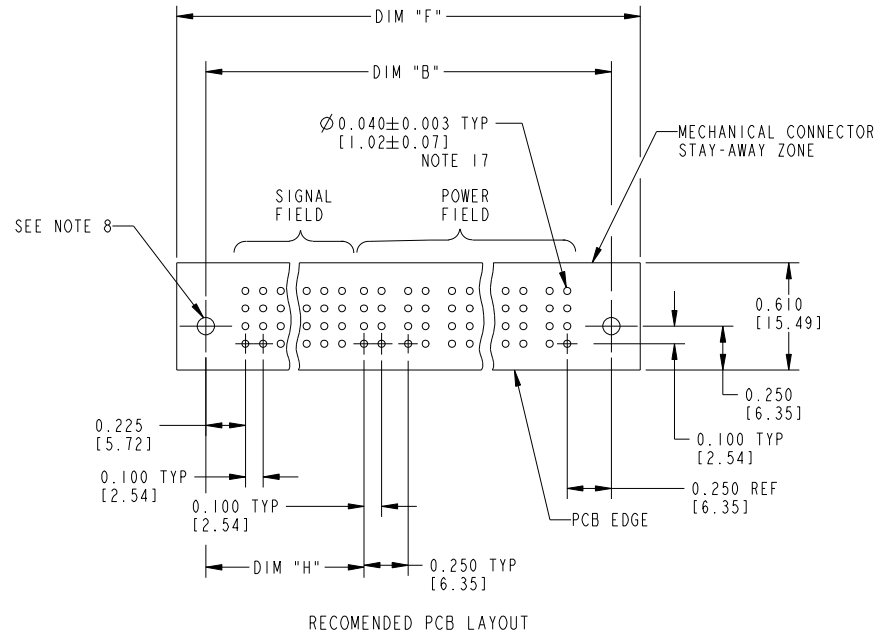
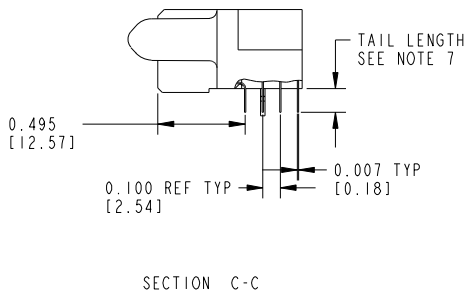
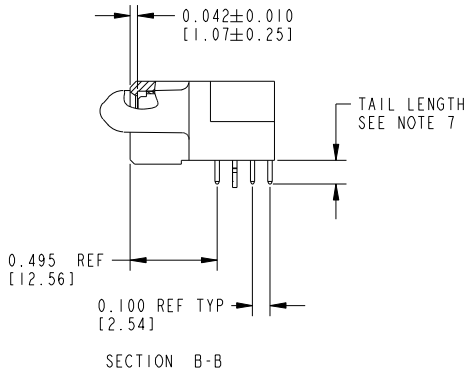
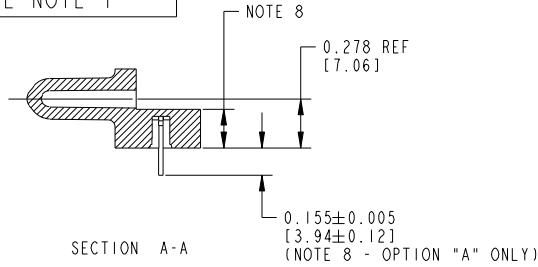

mat'l code				tolerances unless otherwise specified		CUSTOMER COPY		FCI www.fciconnect.com	
ltr	ecn no.	dr	date	linear	.XX±.01/.X±.3	projection		title RIGHT ANGLE RECEPTACLE w/GUIDE PIN POWER / SIGNAL	
K				angles	.XXX±.005/.XX±.13 .XXX±.0020/.XX±.051			product family PWRLADE	code 213
				dr	0°±2°	INCH / MM	size	dwg no	SHEET
				enr	J. BROWN 05-18-99	scale	A	51762	3 OF 3
				chr	J. BROWN 05-18-99				
				appd	J. BROWN 05-18-99				
sheet index	revision sheet								

form no. 7530-001-103

cage code 22526