

HIGH-EFFICIENCY PREDICTIVE SYNCHRONOUS BUCK DRIVER

FEATURES

- Maximizes Efficiency by Minimizing Body-Diode Conduction and Reverse Recovery Losses
- Transparent Synchronous Buck Gate Drive Operation From the Single Ended PWM Input Signal
- 12-V or 5-V Input Operation
- 3.3-V Input Operation With Availability of 12-V Bus Bias
- On-Board 6.5-V Gate Drive Regulator
- ± 3.3 -A TrueDrive™ Gate Drives for High Current Delivery at MOSFET Miller Thresholds
- Automatically Adjusts for Changing Operating Conditions
- Thermally Enhanced 14-Pin PowerPAD™ HTSSOP Package Minimizes Board Area and Junction Temperature Rise

APPLICATIONS

- Non-Isolated Single or Multi-phased DC-to-DC Converters for Processor Power, General Computer, Telecom and Datacom Applications

DESCRIPTION

The UCC27221 and UCC27222 are high-speed synchronous buck drivers for today's high-efficiency, lower-output voltage designs. Using Predictive Gate Drive™ (PGD) control technology, these drivers reduce diode conduction and reverse recovery losses in the synchronous rectifier MOSFET(s). The UCC27221 has an inverted PWM input while the UCC27222 has a non-inverting PWM input.

Predictive Gate Drive™ technology uses control loops which are stabilized internally and are therefore transparent to the user. These loops use no external components, so no additional design is needed to take advantage of the higher efficiency of these drivers.

This closed loop feedback system detects body-diode conduction, and adjusts deadtime delays to minimize the conduction time interval. This virtually eliminates body-diode conduction while adjusting for temperature, load-dependent delays, and for different MOSFETs. Precise gate timing at the nanosecond level reduces the reverse recovery time of the synchronous rectifier MOSFET body-diode, reducing reverse recovery losses seen in the main (high-side) MOSFET. The lower junction temperature in the low-side MOSFET increases product reliability. Since the power dissipation is minimized, a higher switching frequency can also be used, allowing for smaller component sizes.

The UCC27221 and UCC27222 are offered in the thermally enhanced 14-pin PowerPAD™ package with $2^{\circ}\text{C}/\text{W}$ θ_{jC} .

FUNCTIONAL APPLICATION DIAGRAM

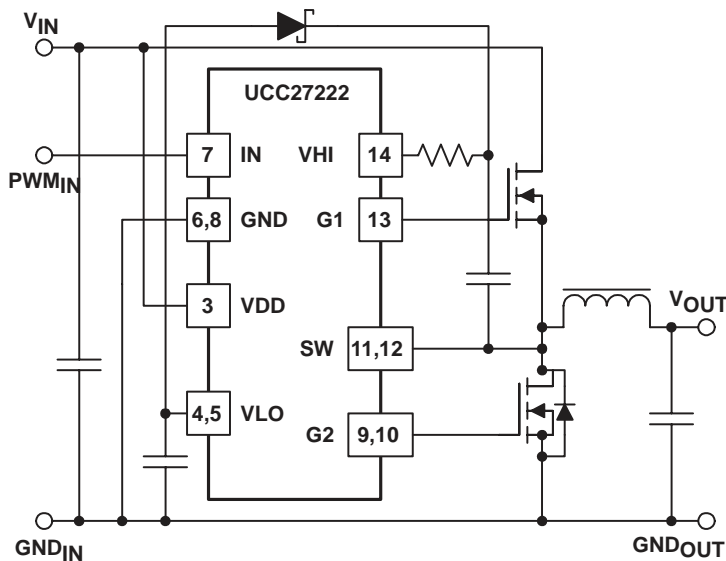

Note: 12-V input system shown. For 5-V input only systems, see Figure 6.

Predictive Gate Drive™ and PowerPAD™ are trademarks of Texas Instruments Incorporated.

PRODUCTION DATA information is current as of publication date. Products conform to specifications per the terms of Texas Instruments standard warranty. Production processing does not necessarily include testing of all parameters.

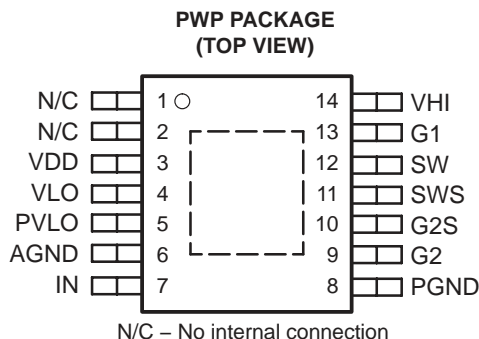

AVAILABLE OPTIONS

T _A	PWM INPUT (IN)	PACKAGED DEVICES
		PowerPAD™ HTSSOP-14 (PWP)
-40°C to 105°C	INVERTING	UCC27221PWP
	NON-INVERTING	UCC27222PWP

†The PWP package is available taped and reeled. Add R suffix to device type (e.g. UCC27221PWPR) to order quantities of 2,000 devices per reel and 90 units per tube.

absolute maximum ratings over operating free-air temperature (unless otherwise noted)†‡

Supply voltage range, VDD	-0.3 to 20 V
Input voltage, VHI	30 V
SW, SWS	20 V
Supply current, I _{DD} , including gate drive current	100 mA
Sink current (peak) pulsed, G1/G2	4.0 A
Source current (peak) pulsed, G1/G2	-4.0 A
Analog input, IN	-3.0 V to V _{DD} + 0.3 V, not to exceed 15 V
Power Dissipation at T _A = 25°C (PWP package)	3 W
Operating junction temperature range, T _J	-55°C to 115°C
Storage temperature range, T _{stg}	-65°C to 150°C
Lead temperature soldering 1.6 mm (1/16 inch) from case for 10 seconds	300°C

† Stresses beyond those listed under “absolute maximum ratings” may cause permanent damage to the device. These are stress ratings only, and functional operation of the device at these or any other conditions beyond those indicated under “recommended operating conditions” is not implied. Exposure to absolute-maximum-rated conditions for extended periods may affect device reliability.

‡ All voltages are with respect to AGND and PGND. Currents are positive into, negative out of the specified terminal.

ELECTRICAL CHARACTERISTICS

$V_{DD} = 12\text{-V}$, 1- μF capacitor from VDD to GND, 1- μF capacitor from VHI to SW, 0.1- μF and 2.2- μF capacitor from PVLO to PGND, PVLO tied to VLO, $T_A = -40^\circ\text{C}$ to 105°C for the UCC2722x, $T_A = T_J$ (unless otherwise noted)

VLO regulator

PARAMETER	TEST CONDITIONS	MIN	TYP	MAX	UNIT
Regulator output voltage	$V_{DD} = 12\text{ V}$, $I_{VLO} = 0\text{ mA}$	6.2	6.5	6.8	V
	$V_{DD} = 20\text{ V}$, $I_{VLO} = 0\text{ mA}$	6.2	6.5	6.8	
	$V_{DD} = 8.5\text{ V}$, $I_{VLO} = 100\text{ mA}$	6.1	6.5	6.9	
Line Regulation	$V_{DD} = 12\text{ V}$ to 20 V		2	10	mV
Load Regulation	$I_{VLO} = 0\text{ mA}$ to 100 mA		15	40	
Short-circuit current ⁽¹⁾	$V_{DD} = 8.5\text{ V}$		220		mA
Dropout voltage, (VDD at 5% VLO drop)	$VLO = 6.175\text{ V}$, $I_{VLO} = 100\text{ mA}$	7.1	7.8	8.5	V

undervoltage lockout

PARAMETER	TEST CONDITIONS	MIN	TYP	MAX	UNIT
Start threshold voltage	Measured at VLO	3.30	3.82	4.40	V
Minimum operating voltage after start		3.15	3.70	4.25	
Hysteresis		0.07	0.12	0.20	

bias currents

PARAMETER	TEST CONDITIONS	MIN	TYP	MAX	UNIT
V_{LO} bias current at VLO (ON), 5 V applications only	$VLO = 4.5\text{ V}$, $V_{DD} = \text{no connect}$	3.6	4.7	5.8	mA
V_{DD} bias current	$V_{DD} = 8.5\text{ V}$	5.5	7.1	8.5	
	$f_{IN} = 500\text{ kHz}$, No load on G1/G2	5.5	10	20	

input command (IN)

PARAMETER	TEST CONDITIONS	MIN	TYP	MAX	UNIT
High-level input voltage	$10\text{ V} < V_{DD} < 20\text{ V}$	3.3	3.6	3.9	V
Low-level input voltage	$10\text{ V} < V_{DD} < 20\text{ V}$	2.2	2.5	2.8	
Input bias current	$V_{DD} = 15\text{ V}$			1	μA

input (SWS)

PARAMETER	TEST CONDITIONS	MIN	TYP	MAX	UNIT
High-level input threshold voltage	$f_{IN} = 500\text{ kHz}$, $G2S = 0.0\text{ V}$, $t_{ON}, G2$ maximum,	1.4	2.0	2.6	V
Low-level input threshold voltage	$f_{IN} = 500\text{ kHz}$, $G2S = 0.0\text{ V}$, $t_{ON}, G2$ minimum,	0.7	1.0	1.3	
	$f_{IN} = 500\text{ kHz}$, $t_{ON}, G1$ minimum	-100	-300	-500	mV
Input bias current	$SWS = 0.0\text{ V}$	-0.9	-1.2	-1.5	mA

input (G2S)

PARAMETER	TEST CONDITIONS	MIN	TYP	MAX	UNIT
High-level input voltage	$f_{IN} = 500\text{ kHz}$, $SWS = 0.0\text{ V}$, $t_{ON}, G2$ maximum,	1.4	2.0	2.6	V
Low-level input voltage	$f_{IN} = 500\text{ kHz}$, $SWS = 0.0\text{ V}$, $t_{ON}, G2$ minimum,	0.7	1.0	1.3	
Input bias current	$G2S = 0\text{ V}$	-370	-470	-570	μA

NOTE 1: Ensured by design. Not production tested.

ELECTRICAL CHARACTERISTICS

$V_{DD} = 12\text{-V}$, $1\text{-}\mu\text{F}$ capacitor from V_{DD} to GND , $1\text{-}\mu\text{F}$ capacitor from V_{HI} to SW , $0.1\text{-}\mu\text{F}$ and $2.2\text{-}\mu\text{F}$ capacitor from $PVLO$ to $PGND$, $PVLO$ tied to VLO , $T_A = -40^\circ\text{C}$ to 105°C for the UCC2722x, $T_A = T_J$ (unless otherwise noted)

G1 main output

PARAMETER	TEST CONDITIONS	MIN	TYP	MAX	UNIT
Sink resistance	$SW = 0\text{ V}$, $V_{HI} = 6\text{ V}$, $IN = 0\text{ V}$, $G1 = 0.5\text{ V}$	0.3	0.9	1.5	Ω
Source resistance ⁽²⁾	$SW = 0\text{ V}$, $V_{HI} = 6\text{ V}$, $IN = 6.5\text{ V}$, $G1 = 5.5\text{ V}$	10	25	45	
Source current ⁽¹⁾⁽²⁾	$SW = 0\text{ V}$, $V_{HI} = 6\text{ V}$, $IN = 6.5\text{ V}$, $G1 = 3.0\text{ V}$	-3	-3.3		A
Sink current ⁽¹⁾⁽²⁾	$SW = 0\text{ V}$, $V_{HI} = 6\text{ V}$, $IN = 0\text{ V}$, $G1 = 3.0\text{ V}$	3	3.3		
Rise time	$C = 2.2\text{ nF}$ from $G1$ to SW , $V_{DD} = 20\text{ V}$		17	25	ns
Fall time	$C = 2.2\text{ nF}$ from $G1$ to SW , $V_{DD} = 20\text{ V}$		17	25	

G2 SR output

PARAMETER	TEST CONDITIONS	MIN	TYP	MAX	UNIT
Sink resistance ⁽²⁾	$PVLO = 6.5\text{ V}$, $IN = 6.5\text{ V}$, $G1 = 0.25\text{ V}$	5	15	30	Ω
Source resistance ⁽²⁾	$PVLO = 6.5\text{ V}$, $IN = 0\text{ V}$, $G2 = 6.0\text{ V}$	10	20	35	
Source current ⁽¹⁾⁽²⁾	$PVLO = 6.5\text{ V}$, $IN = 0\text{ V}$, $G2 = 3.25\text{ V}$	-3	-3.3		A
Sink current ⁽¹⁾⁽²⁾	$PVLO = 6.5\text{ V}$, $IN = 6.5\text{ V}$, $G2 = 3.25\text{ V}$	3	3.3		
Rise time ⁽²⁾	$C = 2.2\text{ nF}$ from $G2$ to $PGND$, $V_{DD} = 20\text{ V}$		17	25	ns
Fall time	$C = 2.2\text{ nF}$ from $G2$ to $PGND$, $V_{DD} = 20\text{ V}$		20	35	

deadtime delay

PARAMETER	TEST CONDITIONS	MIN	TYP	MAX	UNIT
$t_{OFF, G2, IN}$ to $G2$ falling		60	80	100	ns
$t_{OFF, G1, IN}$ to $G1$ falling		55	80	110	
Delay Step Resolution		3.5	4.1	4.7	
$t_{ON, G1}$ minimum			-15		
$t_{ON, G1}$ maximum			48		
$t_{ON, G2}$ minimum			-21		
$t_{ON, G2}$ maximum			38		

NOTE 1: Ensured by design. Not production tested.

2: The pullup / pulldown circuits of the drivers are bipolar and MOSFET transistors in parallel. The peak output current rating is the combined current from the bipolar and MOSFET transistors. The output resistance is the $R_{DS(ON)}$ of the MOSFET transistor when the voltage on the driver output is less than the saturation voltage of the bipolar transistor.

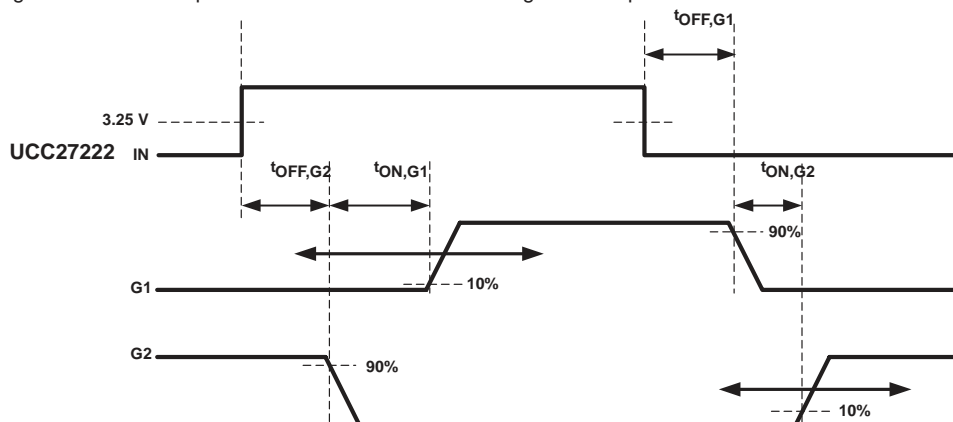

UDG-01042

Figure 1. Predictive Gate Drive Timing Diagram

TERMINAL FUNCTIONS

TERMINAL NAME	NO.	I/O	DESCRIPTION
AGND	6	–	Analog ground for all internal logic circuitry. AGND and PGND should be tied to the PCB ground plane with vias.
G1	13	O	High-side gate driver output that swings between SW and VHI.
G2	9	O	Low-side gate driver output that swings between PGND and PVLO.
G2S	10	I	Used by the predictive deadtime controller for sensing the SR MOSFET gate voltage to set the appropriate deadtime.
IN	7	I	Digital input command pin. A logic high forces on the main switch and forces off the synchronous rectifier.
PGND	8	–	Ground return for the G2 driver. Connect PGND to PCB ground plane with several vias.
PVLO	5	I	PVLO supplies the G2 driver. Connect PVLO to VLO and bypass on the PCB.
SW	12	–	G1 driver return connection.
SWS	11	I	Used by the predictive controller to sense SR body-diode conduction. Connect to SR MOSFET drain close to the MOSFET package.
VDD	3	I	Input to the internal VLO regulator. Nominal VDD range is from 8.5 V to 20 V. Bypass with at least 0.1 μ F of capacitance.
VHI	14	I	Floating G1 driver supply pin. VHI is fed by an external Schottky diode during the SR MOSFET on-time. Bypass VHI to SW with an external capacitor.
VLO	4	O	Output of the VLO regulator and supply input for the logic and control circuitry. Connect VLO to PVLO and bypass on the PCB.

SIMPLIFIED BLOCK DIAGRAM

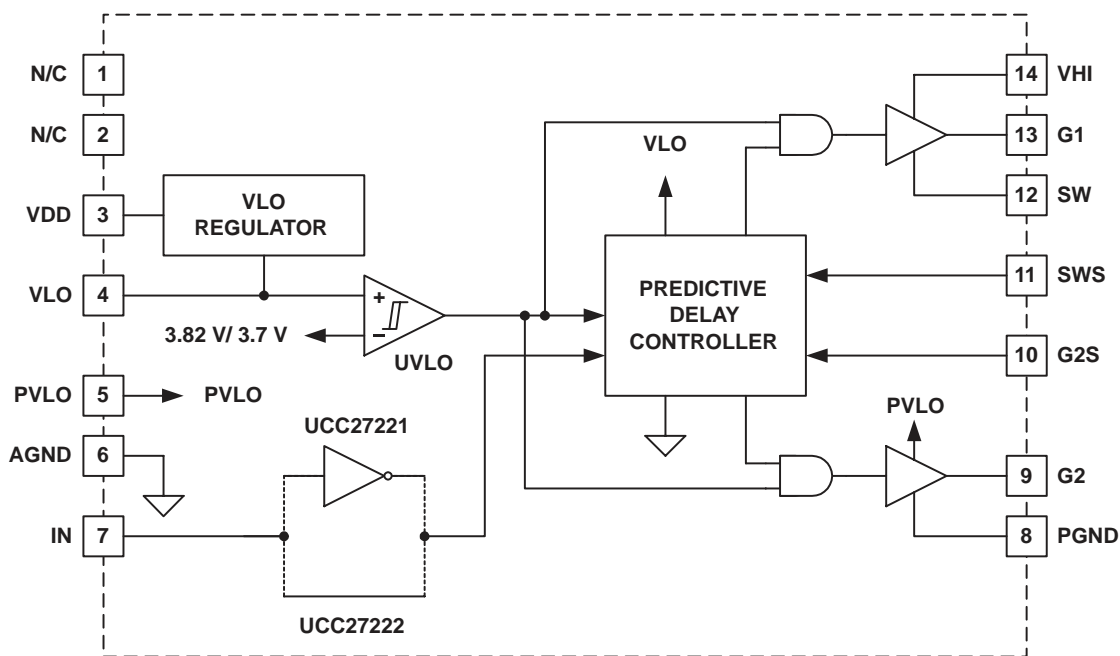

UDG-01030

APPLICATION INFORMATION

predictive gate drive technique

The Predictive Gate Drive™ technology utilizes a digital feedback system to detect body-diode conduction, and then adjusts the deadtime delays to minimize it. This system virtually eliminates the body-diode conduction time intervals for the synchronous MOSFET, while adjusting for different MOSFETs characteristics, propagation and load dependent delays. Maximum power stage efficiency is the end result.

Two internal feedback loops in the predictive delay controller continuously adjusts the turn on delays for the two MOSFET gate drives G1 and G2. As shown in Figure 2, $t_{ON,G1}$ and $t_{ON,G2}$ are varied to provide minimum body-diode conduction in the synchronous rectifier MOSFET Q₂. The turn-off delay for both G1 and G2, $t_{OFF,G1}$ and $t_{OFF,G2}$ are fixed by propagation delays internal to the device.

The predictive delay controller is implemented using a digital control technique, and the time delays are therefore discrete. The turn-on delays, $t_{ON,G1}$ and $t_{ON,G2}$, are changed by a single step (typically 3 ns) every switching cycle. The minimum and maximum turn-on delays for G1 and G2 are specified in the electrical characteristics table.

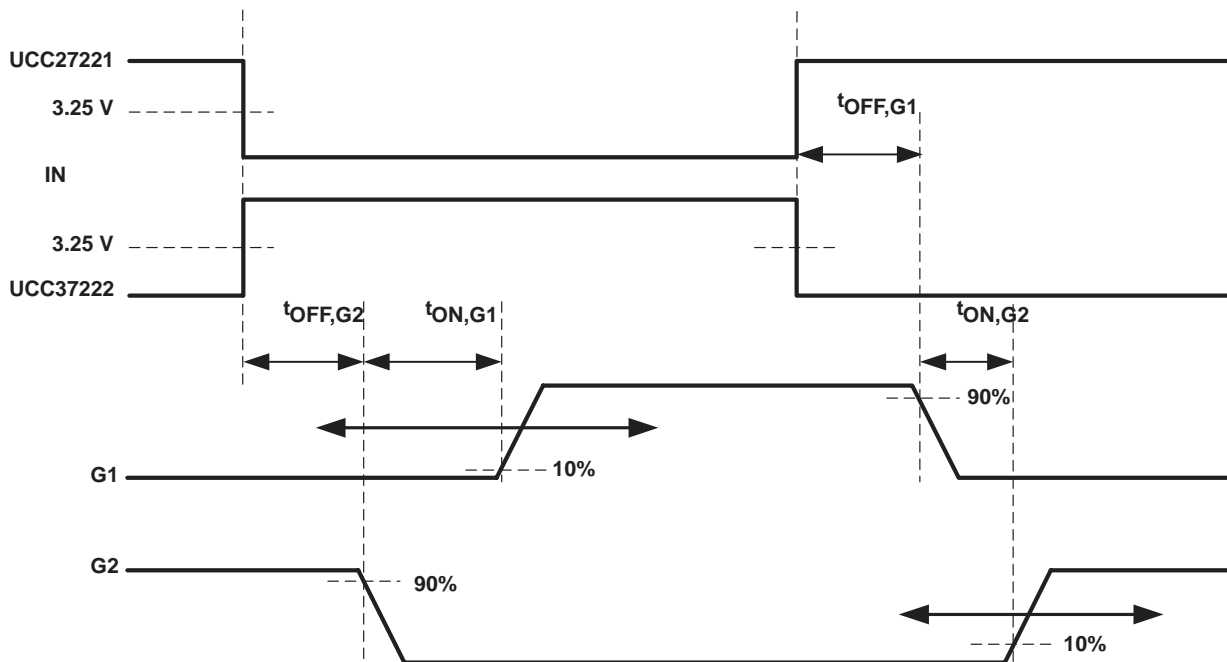

Figure 2. Predictive Gate Drive Timing Diagram

APPLICATION INFORMATION

A typical application circuit for systems with 8.5-V to 20-V input is shown in Figure 3.

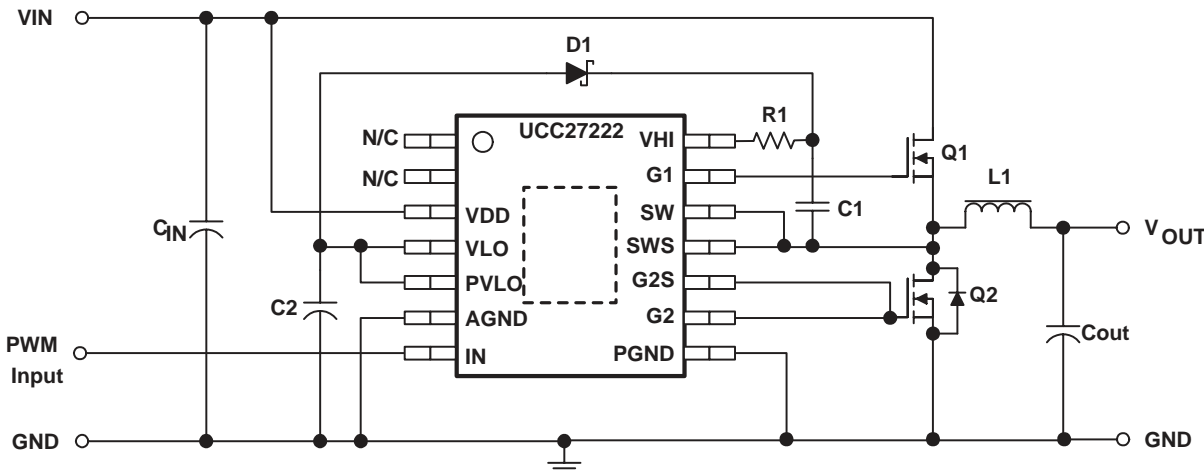

Figure 3. System Application: 8.5-V to 20-V Input

selection of VHI series resistor R1 (dV/dt Considerations):

The series resistor R1 may be needed to slowdown the turn-on of the main forward switch to limit the dV/dt which can inadvertently turn on the synchronous rectifier switch. In nominal 12-V input designs, a R1 value of 4-Ω to 10-Ω can be used depending on the type of MOSFET used and the high-side/low-side MOSFET ratio. In 5-V or lower input applications however, R1 is not needed.

When the drain-source voltage of a MOSFET quickly rises, inadvertent dV/dt induced turn-on of the device is possible. This can especially be a problem for input voltages of 12 V or greater. As Q1 rapidly turns on, the drain-to-source voltage of Q2 rises sharply, resulting in a dV/dt voltage spike appearing on the gate signal of Q2. If the dV/dt induced voltage spike were to exceed the given threshold voltage, the MOSFET may briefly turn on when it should otherwise be commanded off. Obviously this undesired event would have a negative impact on overall efficiency.

Minimizing the dV/dt effect on Q2 can be accomplished by proper MOSFET selection and careful layout techniques. The details of how to select a MOSFET to minimize dV/dt susceptibility are outlined in SEM-1400, Topic 2, Appendix A, Section A5. Secondly, the switch node connecting Q1, Q2 and L1 should be laid out as tight as possible, minimizing any parasitic inductance, which might worsen the dV/dt problem.

If the dV/dt induced voltage spike is still present on the gate Q2, a 4W to 10W value of R1 is recommended to minimize the possibility of inadvertently turning on Q2. The addition of R1 slows the turn-on of Q1, limiting the dV/dt rate appearing on the drain-to-source of Q2. Slowing down the turn-on of Q1 will result in slightly higher switching loss for that device only, but the efficiency gained by preventing dV/dt turn-on of Q2 will far outweigh the negligible effect of adding R1.

When Q2 is optimally selected for dV/dt robustness and careful attention is paid to the PCB layout of the switch node, R1 may not be needed at all, and can therefore be replaced with a 0-Ω jumper to maintain high efficiency. The goal of the designer should not be to completely eliminate the dV/dt turn-on spike but to assure that the maximum amplitude is less than the MOSFET gate-to-source turn-on threshold voltage under all operating conditions.

APPLICATION INFORMATION

selection of bypass capacitor C1

Bypass capacitors should be selected based upon allowable ripple voltage, usually expressed as a percent of the regulated power supply rail to be bypassed. In all of the UCC27222 application circuits shown herein, C1 provides the bypass for the main (high-side) gate driver. Every time Q1 is switched on, a packet of charge is removed from C1 to charge Q1’s gate to approximately 6.0 V. The charge delivered to the gate of Q1 can be found in the manufacturer’s datasheet curves. An example of a gate charge curve is shown in Figure 4.

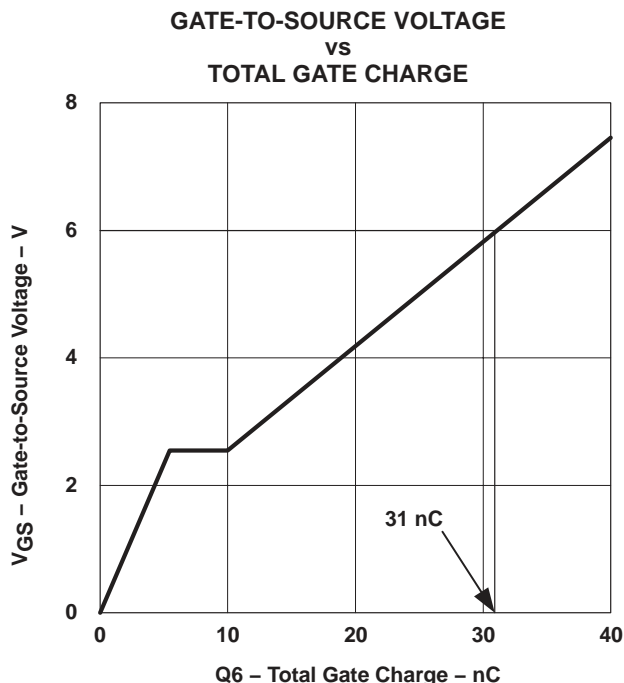

Figure 4.

As shown in Figure 4, 31 nC of gate charge is required in order for Q1’s gate to be charged to 6.0 V, relative to its source. The minimum bypass capacitor value can be found using the following calculation:

$$C1_{MIN} = \frac{Q_G}{k \times (V_{HI} - V_{SW})} \tag{1}$$

where k is the percent ripple on C1, Q_G is the total gate charge required to drive the gate of Q1 from zero to the final value of (V_{HI}–V_{SW}). In this example gate charge curve, the value of the quantity (V_{HI}–V_{SW}) is taken to be 6.0 V. This value represents the nominal VLO regulator output voltage minus the forward voltage drop of the external Schottky diode, D1. For the MOSFET with the gate charge described in Figure 4, the minimum capacitance required to maintain a 3% peak-to-peak ripple voltage can be calculated to be 172 nF, so a 180-nF or a 220-nF capacitor could be used. The maximum peak-to-peak C1 ripple must be kept below 0.4 V for proper operation.

APPLICATION INFORMATION

selection of MOSFETs

The peak current rating of a driver imposes a limit on the maximum gate charge of the external power MOSFET driven by it. The limit is based on the amount of time needed to deliver or remove the required charge to achieve the desired switching speed during turn-on and turn-off of the external transistor. Hence, there are the families of gate driver circuits with different current ratings.

To demonstrate this, assume a constant time interval for the switching transition and a fixed gate drive amplitude. A larger MOSFET with more gate charge will require higher current capability from the driver to turn-on or turn-off the device in the same amount of time. Accordingly, there is a practical upper limit on gate charge which can be driven by the UCC27222 family of drivers. Considering the current capability of the TrueDrive™ output stage and the available dynamic range (delay adjust range) of the Predictive Gate Drive™ circuitry, this limit is approximately 120 nC of gate charge.

Some higher current applications require several MOSFETs to be connected parallel and driven by the same gate drive signal. If their combined gate charge exceeds 120 nC, the rise and fall times of the gate drive signals will extend and limit the delay adjust range of the PGD circuit in the UCC27222. This may limit the benefits of the PGD technology under certain operating conditions.

Note that there are additional considerations in the gate drive circuit design which influence the maximum gate charge of the external MOSFETs. The most significant of these is the operating frequency which, together with the amount of gate charge, will define the power dissipation in the driver. The allowable power dissipation is a function of the maximum junction and operating temperatures, thermal and reliability considerations.

selection of bypass capacitor C2

C2 supplies the peak current required to turn on the Q2 synchronous rectifier MOSFET, as well as the peak current to charge the C1 capacitor through the bootstrap diode. Since the synchronous MOSFET is turned on with 0 V across its drain-to-source, there is no Miller, or gate-to-drain charge. Therefore the synchronous MOSFET gate can be modeled as a simple linear capacitance. The value of this capacitance can be found from the datasheet's gate charge curve. Referring to Figure 5, the slope of the curve past the Miller plateau indicates the equivalent gate capacitance. Because the Y-axis is described in volts, the capacitance is actually the inverse of the slope of the curve. For example, the curve in Figure 4 has a slope of approximately 2 V / 12 nC over the gate charge range of 10 nC to 40 nC. The equivalent capacitance is 12 nC / 2 V = 6 nF. With the equivalent capacitance, the minimum bypass capacitor value can be calculated as:

$$C2_{\text{MIN}} = \frac{C_{\text{EQ}}}{k} \quad (2)$$

where

- C_{EQ} is the equivalent gate capacitance,
- k is the voltage ripple on C2, expressed as a percentage

For a peak-to-peak ripple of 3%, the minimum C2 capacitor value is calculated to be 200 nF. A 220-nF capacitor would be used in this case.

APPLICATION INFORMATION

regulator current and power dissipation

The regulator current can be calculated from the dc or average current required by the two gate drivers. This current can be expressed as:

$$I_{REG} = F_{SW} \times (C_{EQ} \times V_{LO} + Q_G) \tag{3}$$

Assuming all the power dissipation is internal to the device, and the internal bias current is negligible, the power dissipated by the device is:

$$P_{DIS} = F_{SW} \times (C_{EQ} \times V_{LO} + Q_G) \times V_{DD} \tag{4}$$

For a 500-kHz design, using MOSFETs with the gate charge characteristics shown in Figure 4 for both Q1 and Q2, the average regulator current would be 35 mA, and, when operated from a 12-V input rail, the resulting power dissipation is calculated to be 420 mW.

systems using 3.3-V or 5-V power input and 12-V gate drive

Figure 5 shows a schematic for systems where the power bus input is 5 V and 12 V is available for powering the gate drives. This system provides the 6.5-V gate drive to both MOSFETs, while the power stage operates off the 3.3-V or 5-V bus.

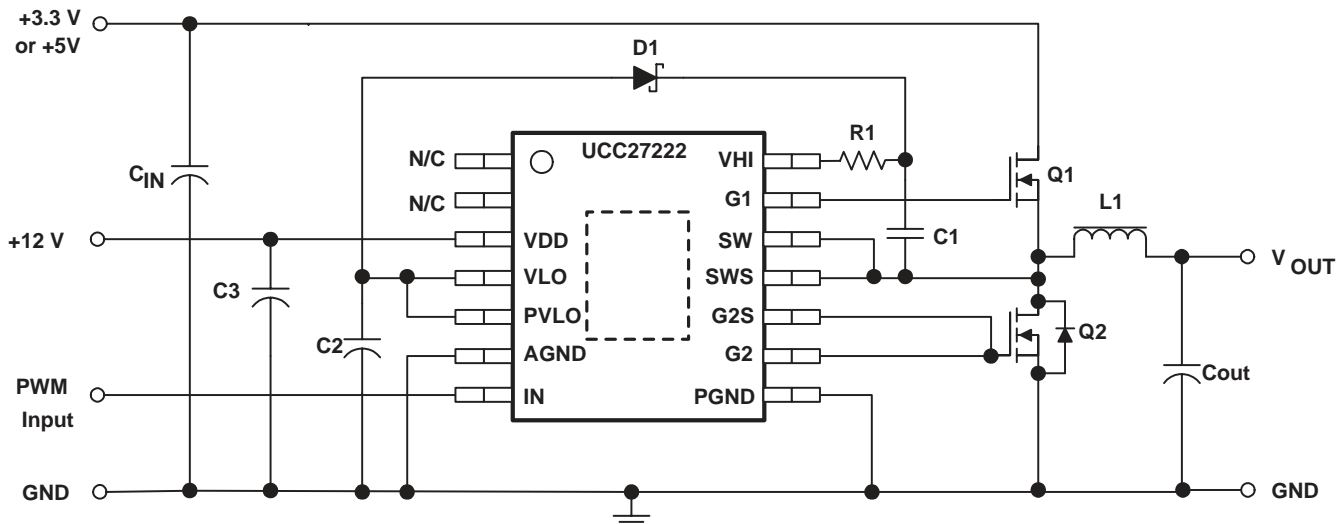

Figure 5. System Application: 3.3-V or 5-V Power Input with 12 V Available for Gate Drive

Note that the series resistor R1 may be needed to slowdown the turn-on of the main forward switch to limit the dV/dt which can inadvertently turn on the synchronous rectifier switch. The dV/dt considerations and the selection of R1 are discussed in the previous section.

APPLICATION INFORMATION

systems with 5-V input only

The circuit pictured in Figure 6 starts up from a 5-V input bus and provides a 6.5-V gate drive to the power MOSFETs. This circuit uses a charge pump consisting of D₃, D₄ and C₃ to effectively double the input voltage and apply this to the input of the linear regulator. The regulator then regulates the doubled input voltage to the 6.5-V nominal for VLO.

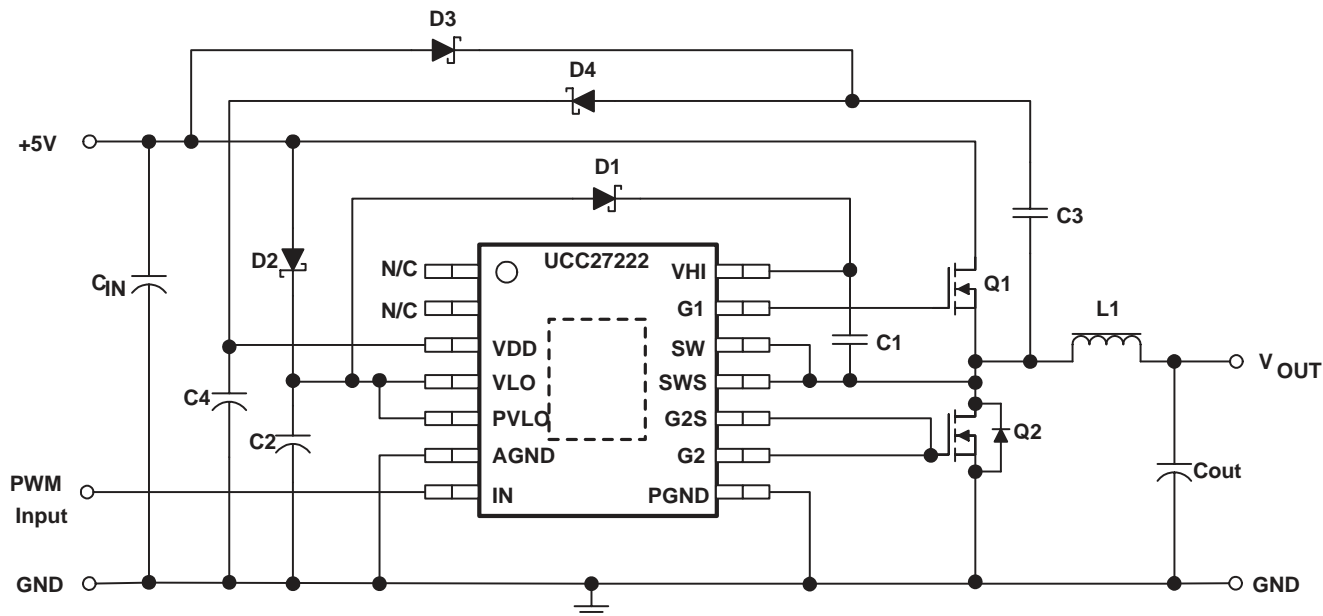

Figure 6. System Application: 5-V-Only Power Input with 6.5-V Gate Drive Using Charge Pump Circuit

APPLICATION INFORMATION

selecting D₂, D₃, and D₄

Selection of suitable diodes is based upon the conducted peak and average currents. D₂ simply provides a path to charge C₂ at converter power-up. Virtually any one of the common BAT54 series of Schottky diodes can be used. To select D₃ and D₄, the peak currents of these two diodes need to be taken into account. First, the average current flowing in both D₃ and D₄ is the same as the regulator current described in equation (3). The peak currents in D₃ and D₄ are described as:

$$I_{D3PK} = \frac{I_{REG}}{1 - D} \quad (5)$$

$$I_{D4PK} = \frac{I_{REG}}{D} \quad (6)$$

For most UCC27222 applications, the duty cycle is much less than 50%, and the peak current in D₃ is quite reasonable. However, the peak current in D₄ is quite high. This high peak current requires using a diode with a higher current rating for D₄.

To maintain a reasonable charge pump efficiency, BAT54-type diodes can be used for applications where the peak currents are below approximately 40 mA. For applications where the peak current is greater than 40 mA, a 350-mA or 500-mA diode should be used. A typical 350-mA diode is SD103CW, SOD-123 package, manufactured by Diodes Inc. A typical 500-mA diode is the ZHCS500, SOT-23 package, available from Zetex Inc.

selection of the flying capacitor C₃

The flying capacitor is subjected to large peak currents, and to keep the peak-to-peak ripple voltage low, this capacitor has to be larger than C₁ and C₂. Selection of C₃ should be done based on allowable peak-to-peak ripple on C₃:

$$C_{3MIN} = \frac{I_{REG}}{F_{SW} \times k \times (V_{IN} - V_{FD3})} \quad (7)$$

where I_{REG} is the regulator output current, F_{SW} is the switching frequency, k is the percent ripple on C₃, and V_{FD3} is the forward drop of D₃.

selection of bypass capacitor C₄

The bypass capacitor C₄ needs to be sized to take the peak current from the charge pump diode D₄. The capacitor is sized based on allowable ripple voltage:

$$C_{MIN} = \frac{I_{REG} \times (1 - D)}{F_{SW} \times k \times (2 \times V_{IN} - V_{FD3} - V_{FD4})} \quad (8)$$

where V_{FD3} and V_{FD4} are the forward voltages of D₃ and D₄ and k is the percent ripple allowed on C₄.

APPLICATION INFORMATION

synchronous rectification and predictive delay

In a normal buck converter, when the main switch turns off, current is flowing to the load in the inductor. This current cannot be stopped immediately without using infinite voltage. For the current path to flow and maintain voltage levels at a safe level, a rectifier or catch device is used. This device can be either a conventional diode, or it can be a controlled active device if a control signal is available to drive it. The UCC27222 provides a signal to drive an N-channel MOSFET as a rectifier. This control signal is carefully coordinated with the drive signal for the main switch so that there is minimum delay from the time that the rectifier MOSFET turns off and the main switch turns on, and minimum delay from when the main switch turns off and the rectifier MOSFET turns on. This scheme, Predictive Gate Drive™ delay, uses information from the current switching cycle to adjust the delays that are to be used in the next cycle. Figure 7 shows the switch-node voltage waveform for a synchronously rectified buck converter. Illustrated are the relative effects of a fixed-delay drive scheme (constant, pre-set delays for the turnoff to turn on intervals), an adaptive delay drive scheme (variable delays based upon voltages sensed on the current switching cycle) and the predictive delay drive scheme.

Note that the longer the time spent in body-diode conduction during the rectifier conduction period, the lower the efficiency. Also, not described in Figure 7 is the fact that the predictive delay circuit can prevent the body diode from becoming forward biased at all while at the same time avoiding cross conduction or shoot through. This results in a significant power savings when the main MOSFET turns on, and minimizes reverse recovery loss in the body diode of the rectifier MOSFET.

The power dissipation on the main (forward) MOSFET is reduced as well, although that savings is not as significant as the savings in the rectifier MOSFET.

During reverse recovery the body diode is still forward biased, thus the reverse recovery current goes through the forward MOSFET while the drain–source voltage is still high, causing additional switching losses. Without PGD during this switching transition, $V_{ds} = V_{in}$ and $I_{ds} = I_{load} + I_{rr}$ in the main MOSFET. With PGD however, $V_{ds} = V_{in}$ and $I_{ds} = I_{load}$. The reduction in current accounts for additional power savings in the main MOSFET.

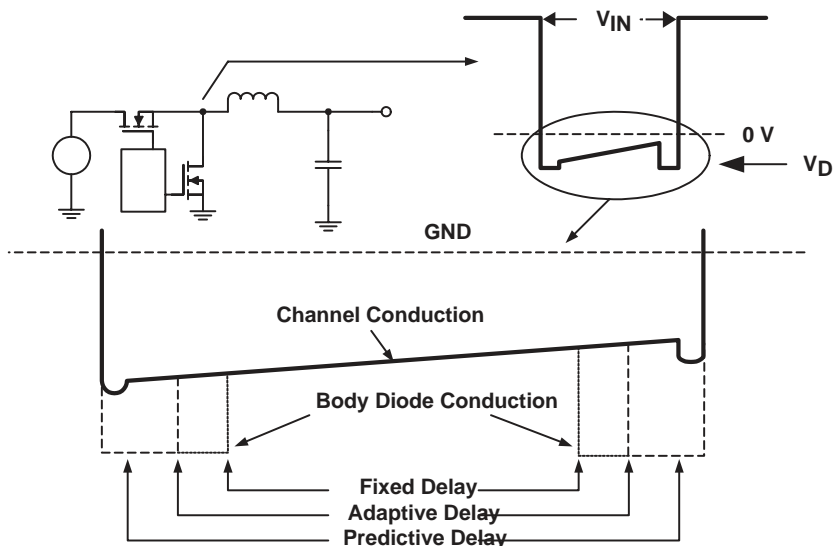

UDG-02175

Figure 7. Switch Node Waveforms for Synchronous Buck Converter

APPLICATION INFORMATION

comparison between predictive and adaptive gate drive techniques

The first synchronous rectifier controllers had a fixed turn-on delay between the two gate drivers. The advantage of this well-known technique is its simplicity. The drawbacks include the need to make the delay times long enough to cover the entire application of the device and the temperature and lot-to-lot variation of the time delay. Since the body-diode of the synchronous rectifier conducts during this deadtime, the efficiency of this technique varies with different MOSFETs, ambient temperature, and with the lot-to-lot variation of the deadtime delay.

To combat the variability of the internal time delays, second generation controllers used state information from the power stage to control the turn-on of the two gate drivers. This technique is usually referred to as adaptive gate drive technique and is pictured in Figure 8.

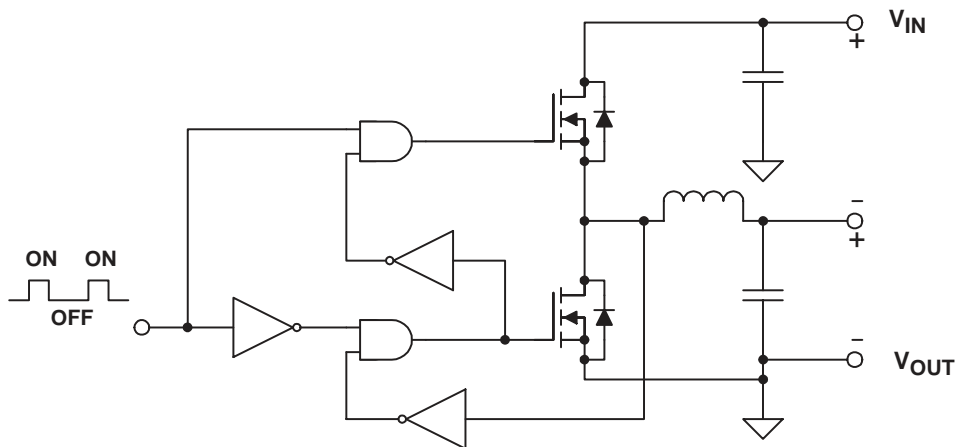

UDG-01031

Figure 8. Adaptive Gate Drive Technique

The main advantage of the adaptive technique is the on-the-fly delay adjustment for different MOSFETs and temperature-variable time delays. The disadvantages include the body-diode conduction time intervals caused by delays in the cross-coupling loops and the inability to compensate for the delay to charge the MOSFET gates to the threshold levels. Additionally, it is difficult to determine whether the synchronous MOSFET channel is off by solely monitoring the SR MOSFET gate voltage. Some devices actually add a programmable delay between the turn-off of the synchronous rectifier and the turn-on of the main MOSFET via an external capacitor. This added delay directly affects the power stage efficiency through additional body-diode conduction losses. Since these losses are centralized in the synchronous MOSFET, the stress and temperature rise in this component becomes a major design headache.

The third-generation predictive control technique is different from the adaptive technique in that it uses information from the previous switching cycle to set the deadtime for the current cycle. The adaptive technique on the other hand uses the current state information to set the delay times. The inherent feedback loop propagation delays cause body-diode conduction.

APPLICATION INFORMATION

adaptive vs. predictive waveforms

Figures 9 through 11 illustrate the adaptive (left) vs. predictive (right) switching waveforms. Key comparison regions are denoted with (A), (B), (C), (D), and (E) for the adaptive control waveforms and (A'), (B'), (C'), (D'), and (E') for the predictive control waveforms. Figures 10 and 11 are close-ups of each transition edge.

At (A), the propagation delay from sensing the synchronous rectifier gate going low to the high-side gate going high results in approximately 60 ns of body-diode conduction shown at (B). With the predictive drive, as soon as the body-diode conduction of the SR MOSFET (B) is sensed, the high-side turn-on delay is adjusted to minimize the body-diode conduction time (B').

At (A'), the high side gate-to-source voltage is increasing while the synchronous rectifier gate-to-source voltage is decreasing. A natural result of the precise timing of the high-side MOSFET turn-on is shown at (C) and (C'). The overshoot and ringing for the predictive drive (C') has much smaller amplitude than the adaptive drive (C) due a reduction in reverse recovery in the SR MOSFET body diode. This reduction in reverse recovery is only possible with the extremely precise gate timing used in the predictive drive technique.

At (D), the propagation delay from the synchronous rectifier drain-to-source voltage falling to the gate-to-source voltage rising causes the body diode of the SR MOSFET to conduct for approximately 60 ns (E). When the predictive drive is enabled (D'), the inherent delay is eliminated and virtually no body-diode conduction is shown at (E').

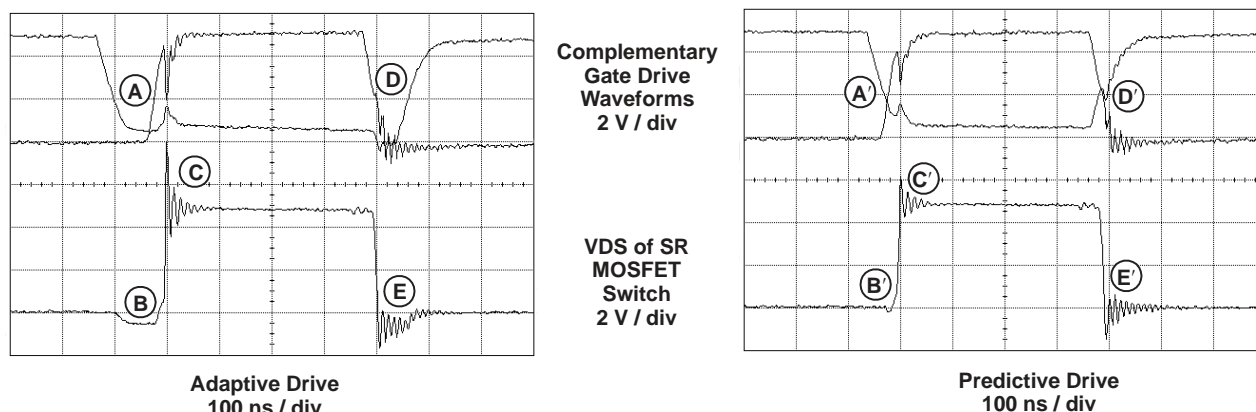

Figure 9. Adaptive vs. Predictive Switching Waveforms

APPLICATION INFORMATION

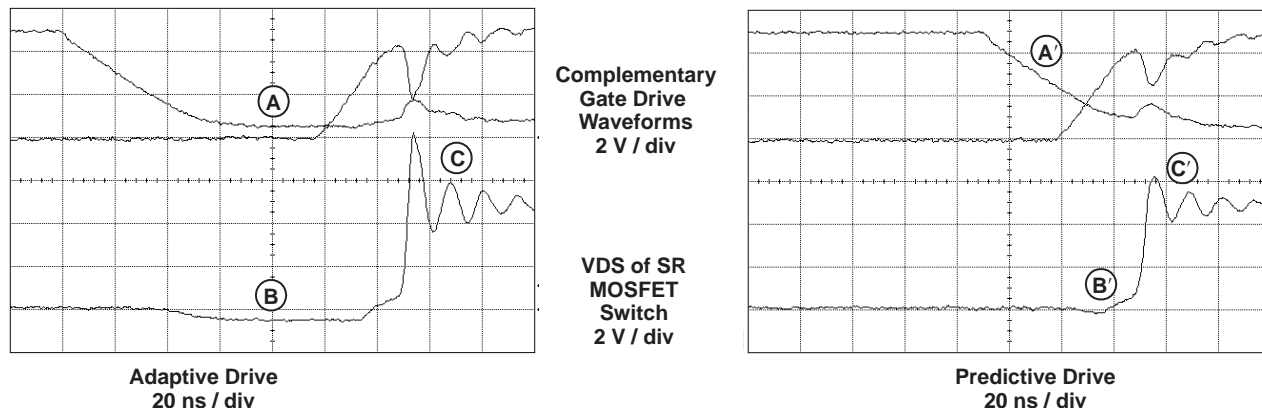

Figure 10. Close-Up: Turn-Off of Synchronous Rectifier Switch to Turn-On of Main Switch

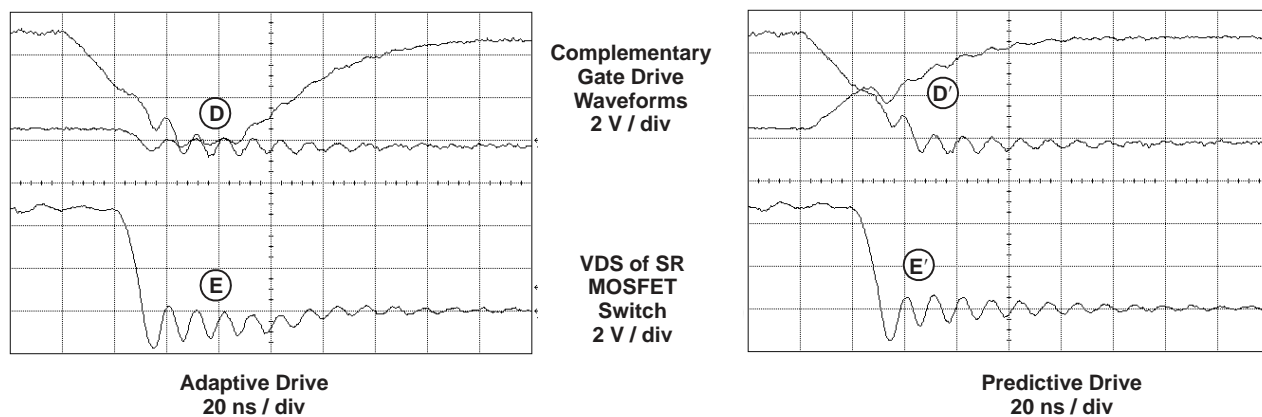

Figure 11. Close-Up: Turn-Off of Main Switch to Turn-On of Synchronous Rectifier Switch

efficiency comparison

Figures 12 through 15 show a series of efficiency measurements taken at two output voltages (0.9 V and 1.8 V) and two switching frequencies (250 kHz and 500 kHz) for both predictive and adaptive delay techniques.

The efficiency gain using the predictive technique is 1% for a V_{OUT} level of 1.8 V and at a switching frequency of 250 kHz (Figure 12). Figures 13 and 14 show the efficiency gain approximately doubles when V_{OUT} is lowered by a factor of two (to 0.9 V), or when the switching frequency is doubled to 500 kHz. With both doubled frequency and one-half of the output voltage, the efficiency gain of predictive technology is about 4% over the adaptive technology (Figure 15). Therefore, as the switching frequency increases and output voltages are lowered, the efficiency gains are higher. This results in lower operational temperatures for increased reliability as well as smaller size designs for increased frequencies.

APPLICATION INFORMATION

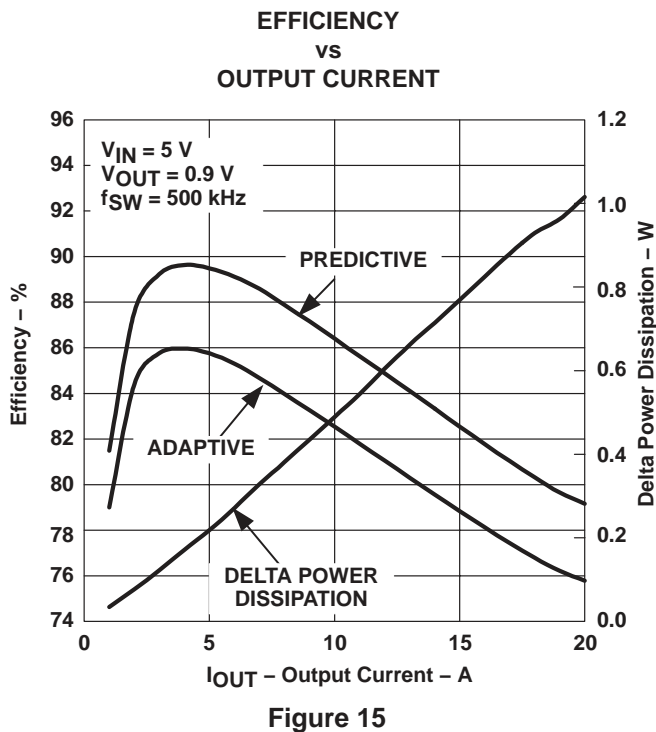
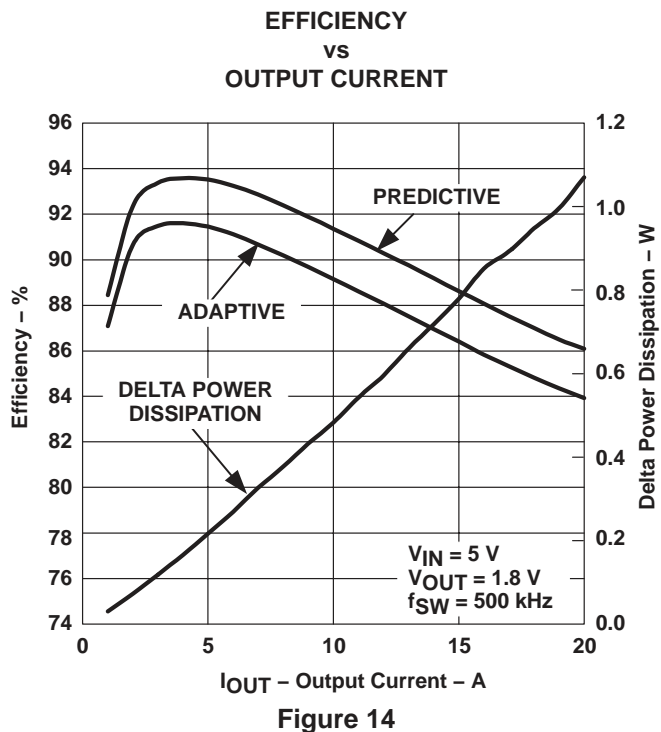
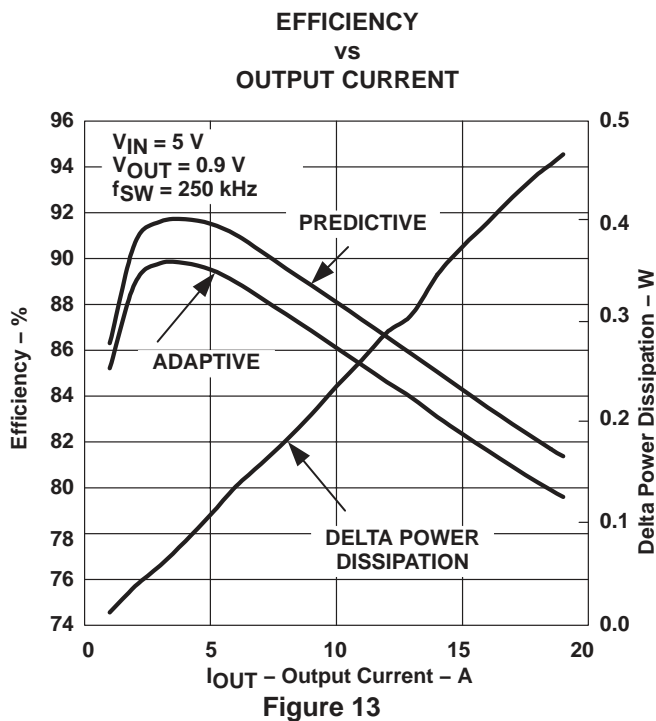
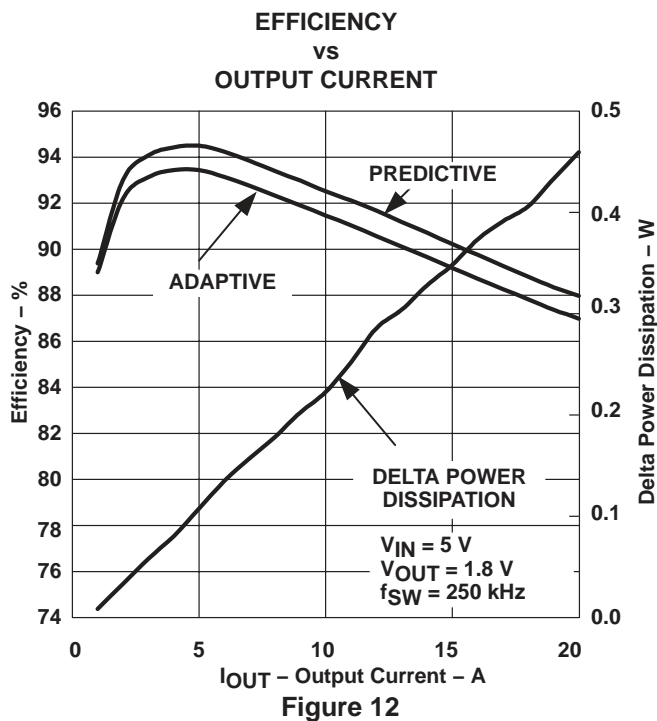

LAYOUT CONSIDERATIONS

packaging

The UCC27221/2 are only available in TI's thermally enhanced 14-pin PowerPad™ package. This package offers exceptional thermal impedance with a junction-to-case rating of 2°C/W. Shown as the crosshatched region in Figure 16, PowerPad™ includes an exposed leadframe die pad located on the bottom side of the package. Exposed pad dimensions for the PowerPad™ TSSOP 14-pin package are 69 mils x 56 mils (1.8 mm x 1.4 mm). However, the exposed pad tolerances can be + 41 / - 2 mils (+ 1.05 / - .05 mm) due to position and mold flow variation. Effectively removing the heat from the PowerPAD™ package requires a thermal land area, shown as the shaded gray region in Figure 16, designed into the PCB directly beneath the package. A minimum thermal land area of 5 mm by 3.4 mm is recommended as illustrated in Figure 16. Any tolerance variances of the exposed PowerPad™ falls well within the thermal land area when the recommended minimum land area is included on the printed circuit board. In addition, a 2-by-3 array of 13-mil thermal vias is required within the exposed PowerPad™ area, as shown in Figure 16. If additional heat sinking capability is required, larger 25-mil vias can be added to the thermal land area.

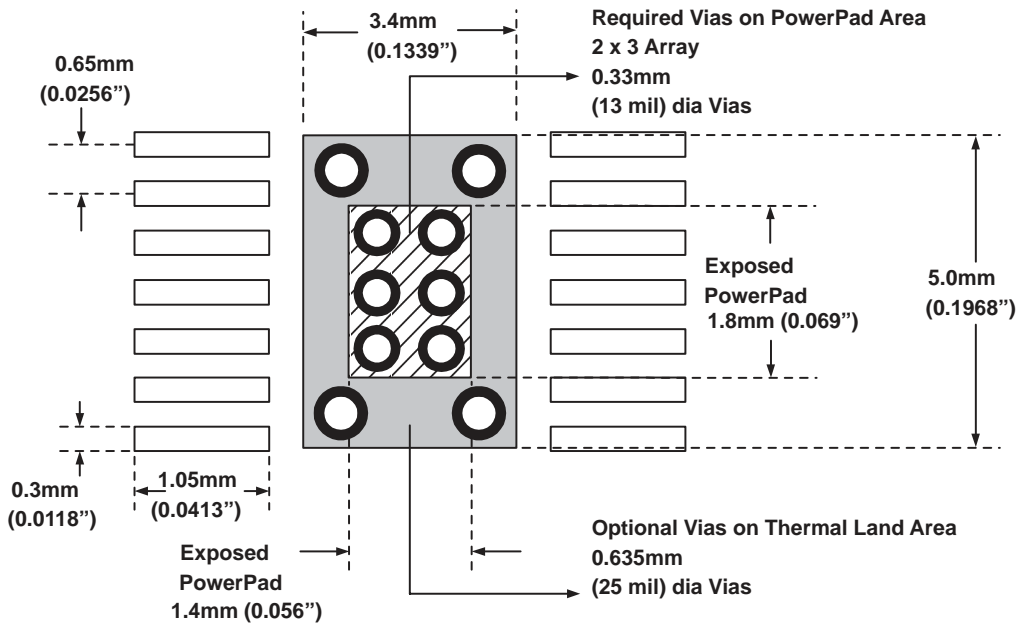

Figure 16. TSSOP-14PWP Package Outline and Minimum PowerPAD™ PCB Thermal Land

REFERENCE DESIGN AND EVALUATION MODULE

A reference design is discussed in, *12 V to 1.8 V, 20-A High Efficiency Synchronous Buck Converter Using the UCC27222 with Predictive Gate Drive™*, TI Literature Number SLUU140 and accompanying evaluation module (EVM) SLUP192. The design highlights UCC27222 and its Predictive Gate Drive™ synchronous buck operation using a simple single ended PWM controller. The schematic is shown in Figure 17.

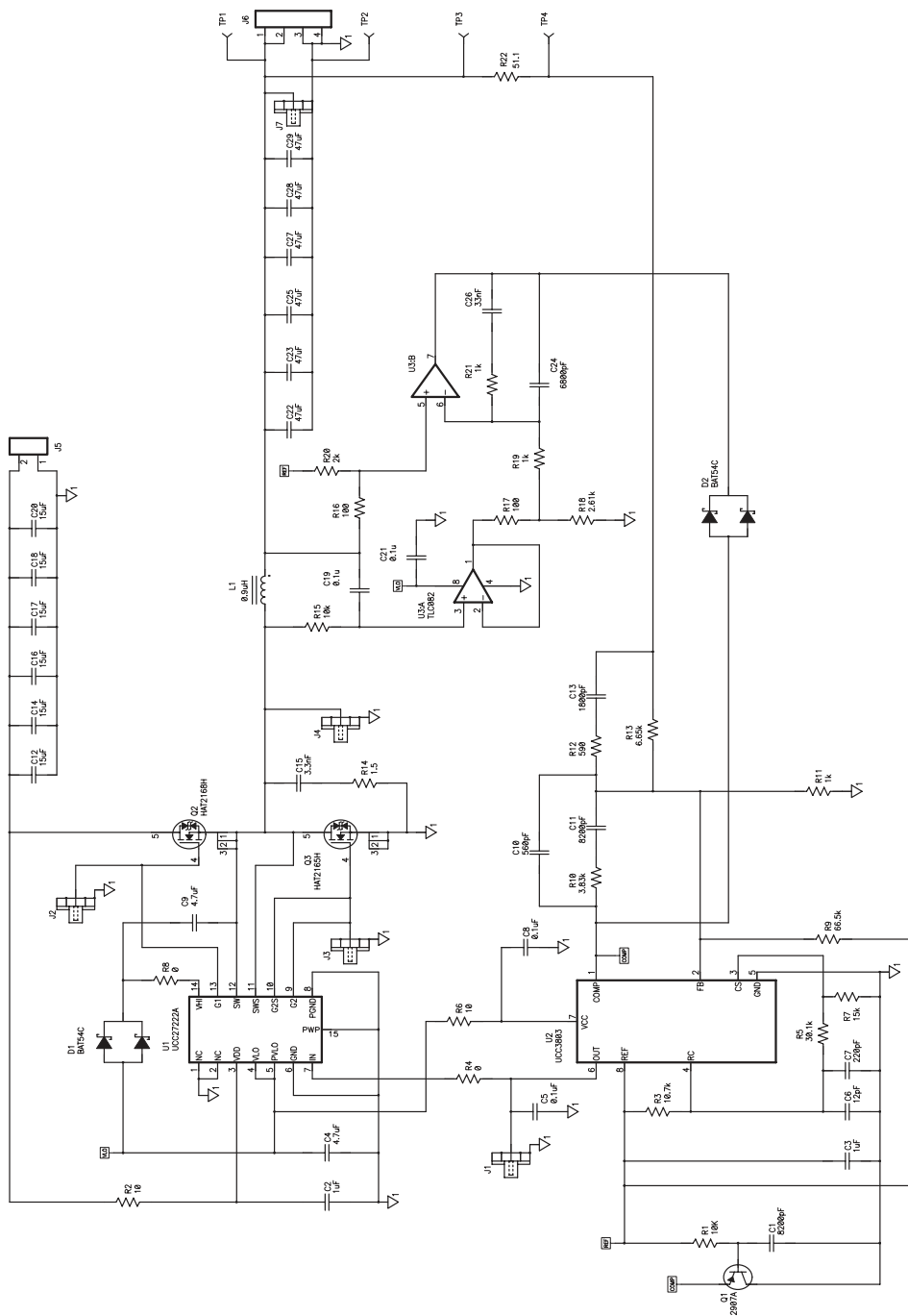
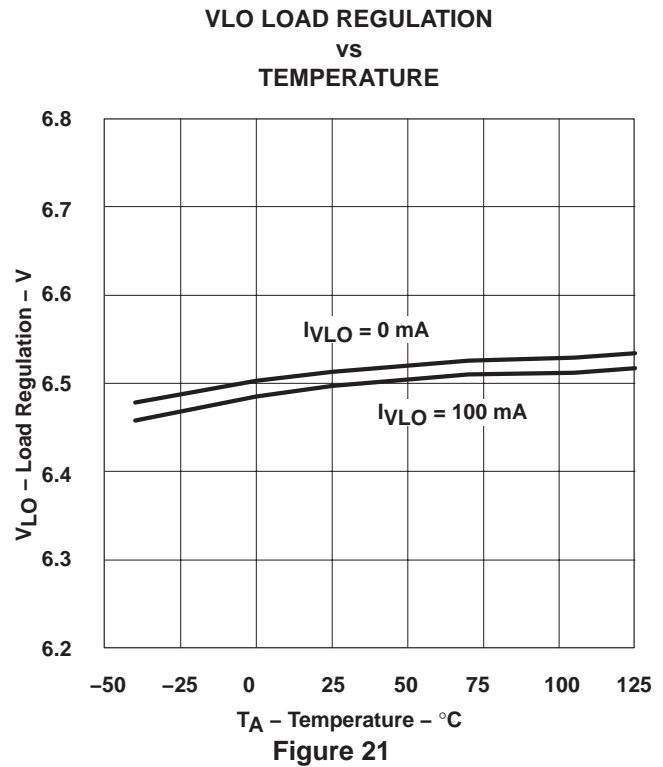
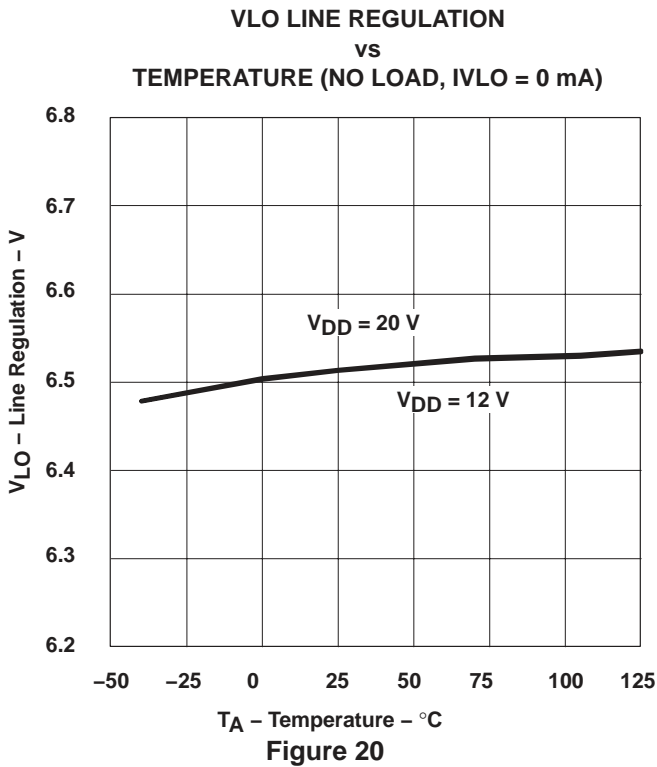
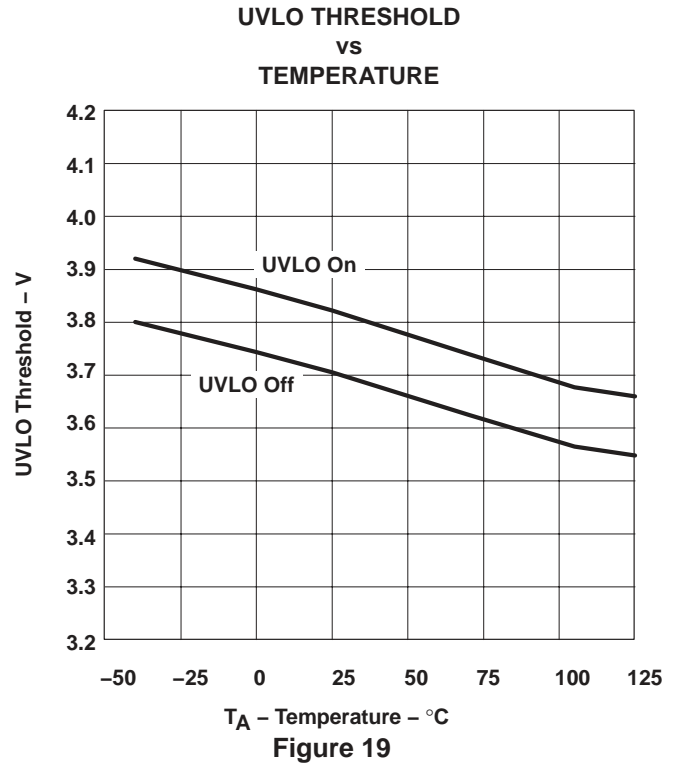
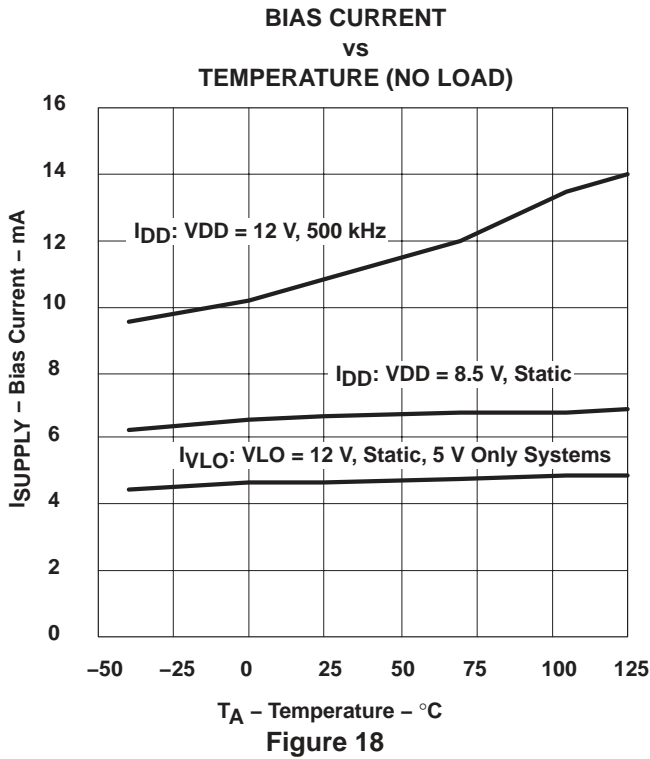

Figure 17. Typical Application Diagram

TYPICAL CHARACTERISTICS



TYPICAL CHARACTERISTICS

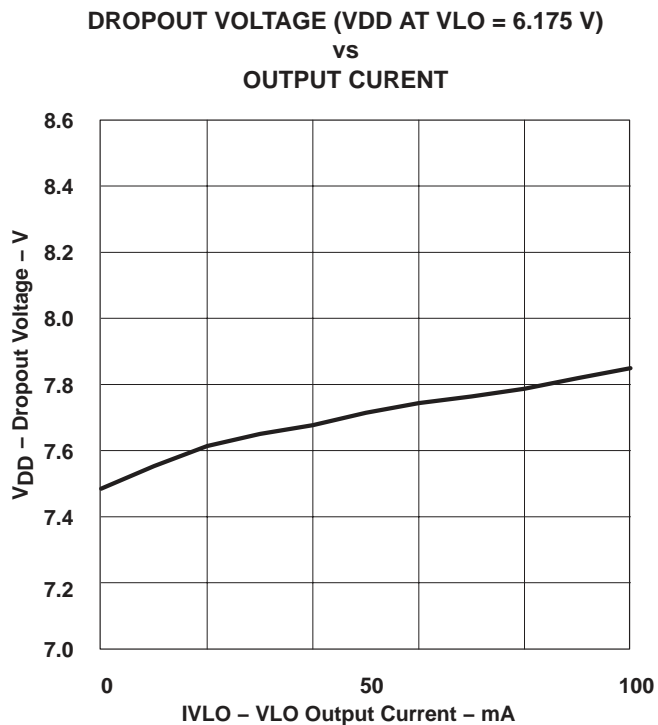

Figure 22

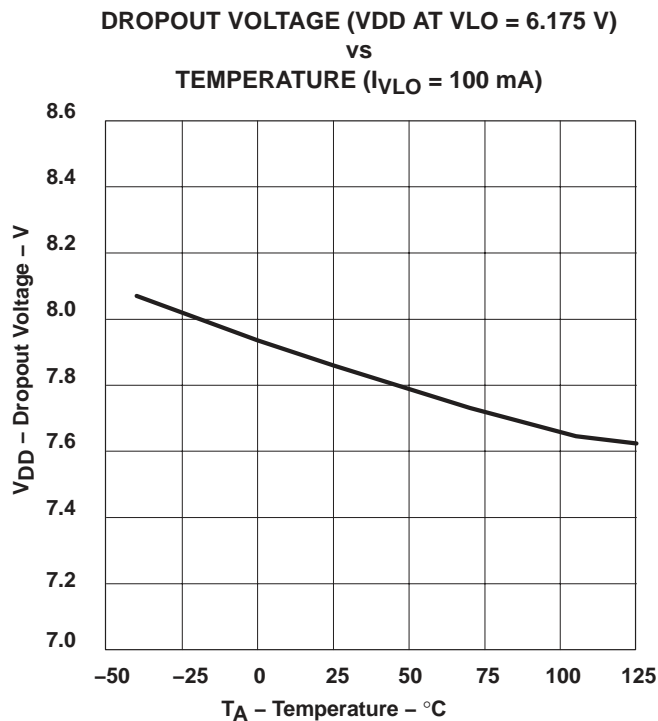

Figure 23

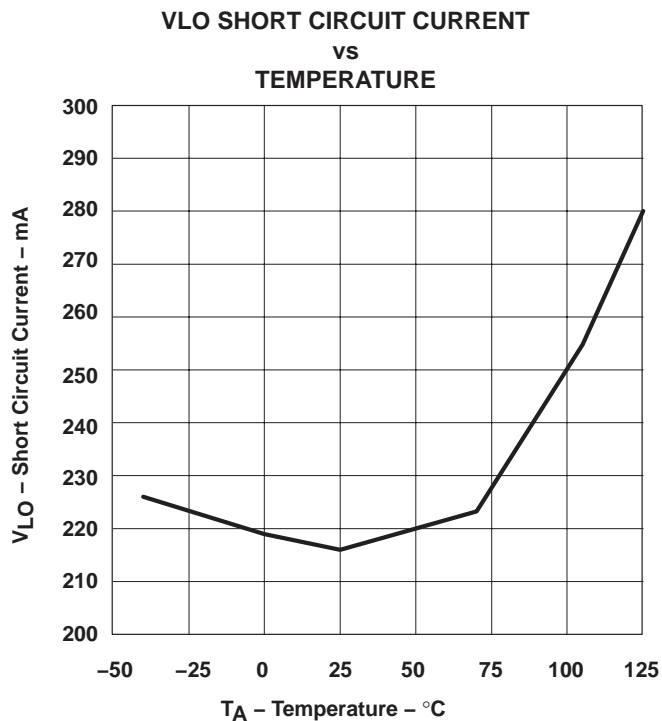

Figure 24

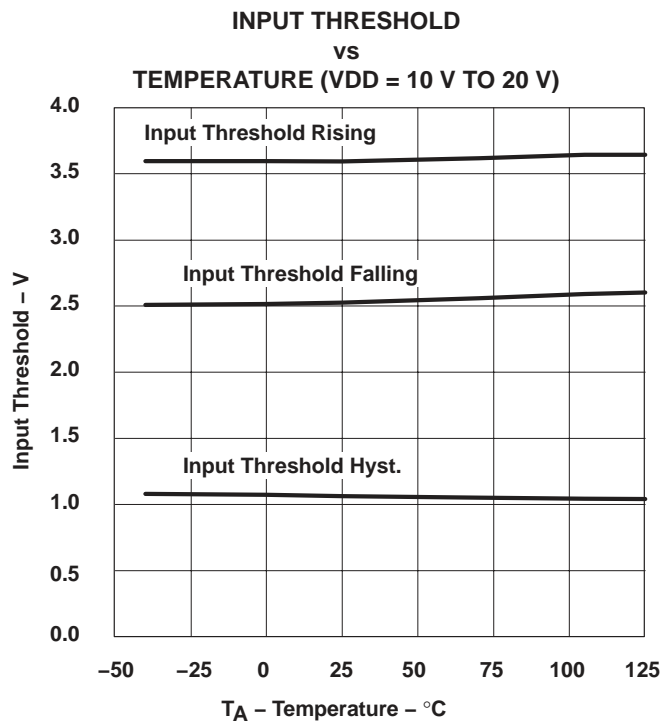

Figure 25

TYPICAL CHARACTERISTICS

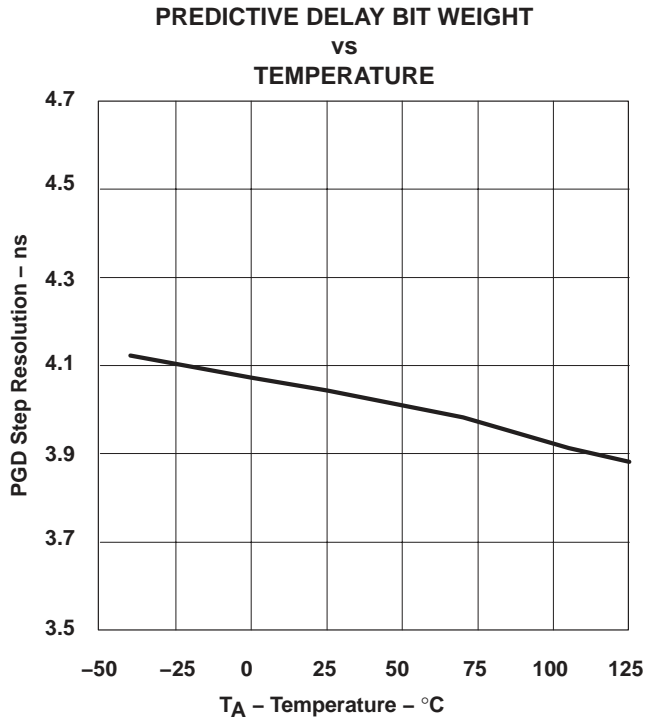

Figure 26

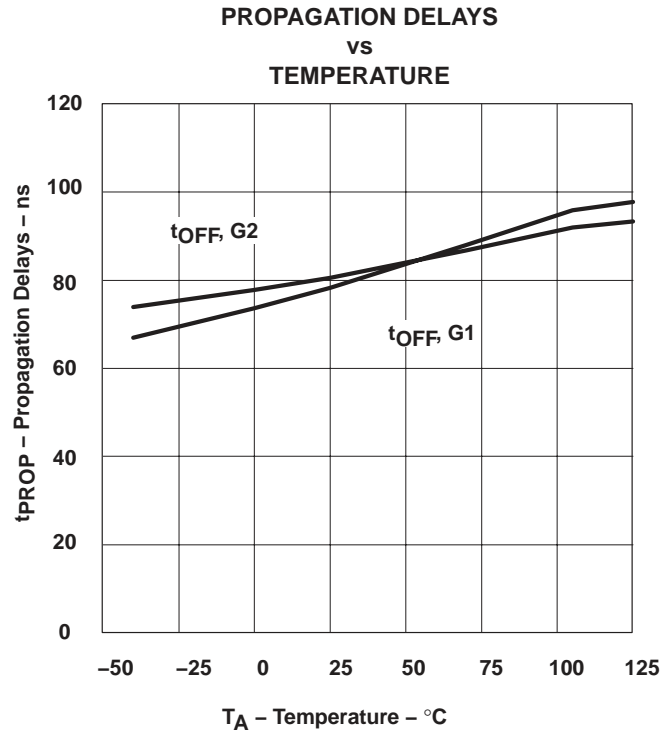

Figure 27

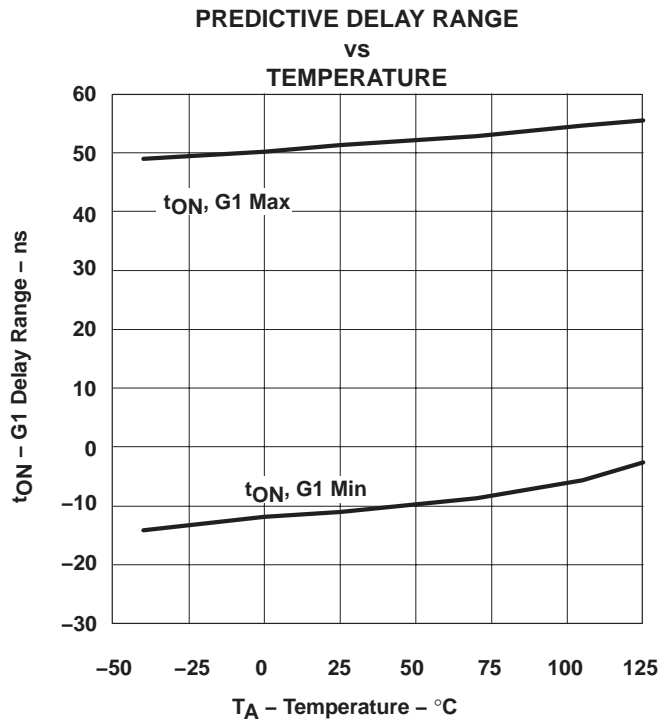

Figure 28

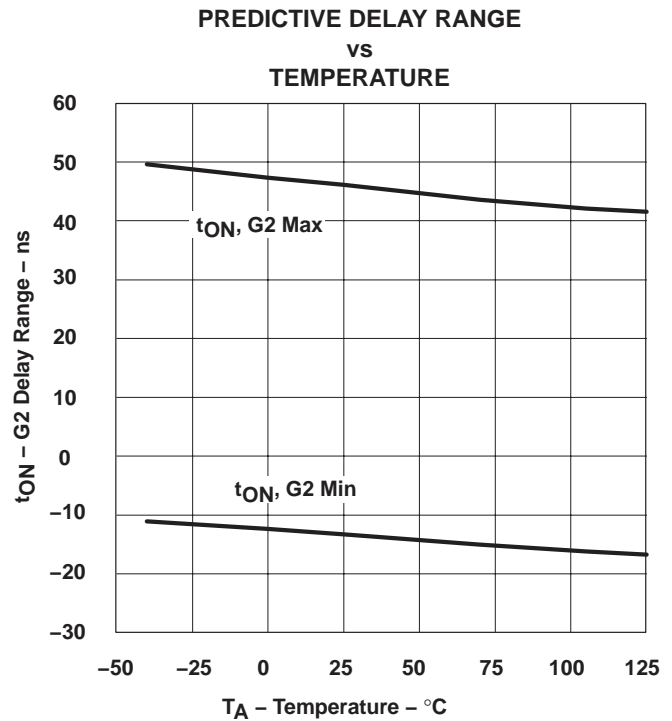

Figure 29

TYPICAL CHARACTERISTICS

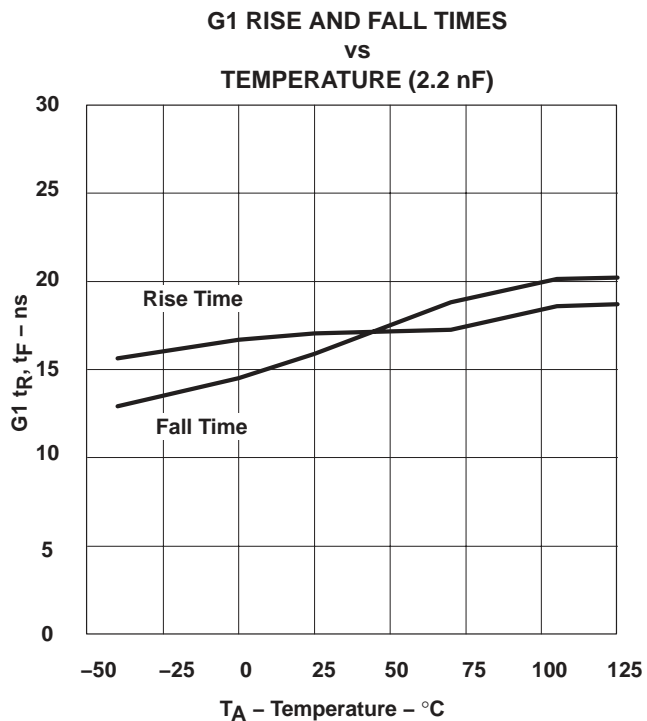

Figure 30

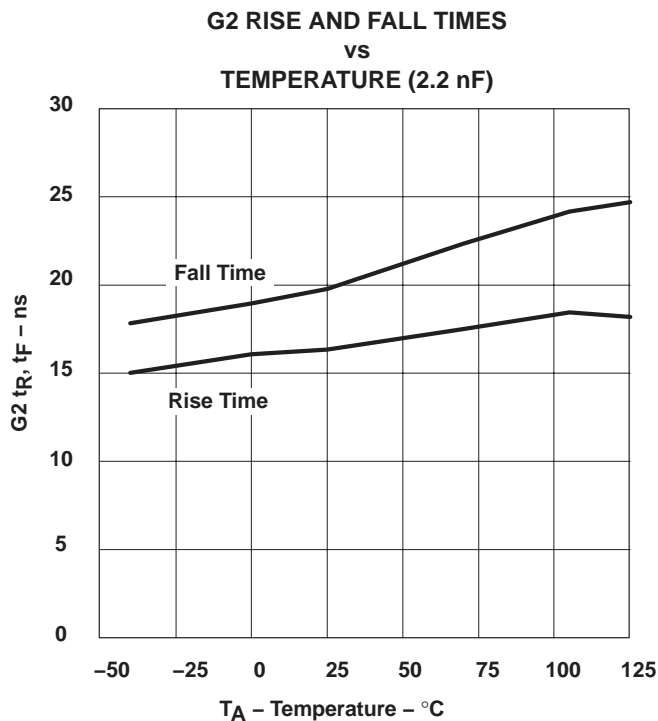

Figure 31

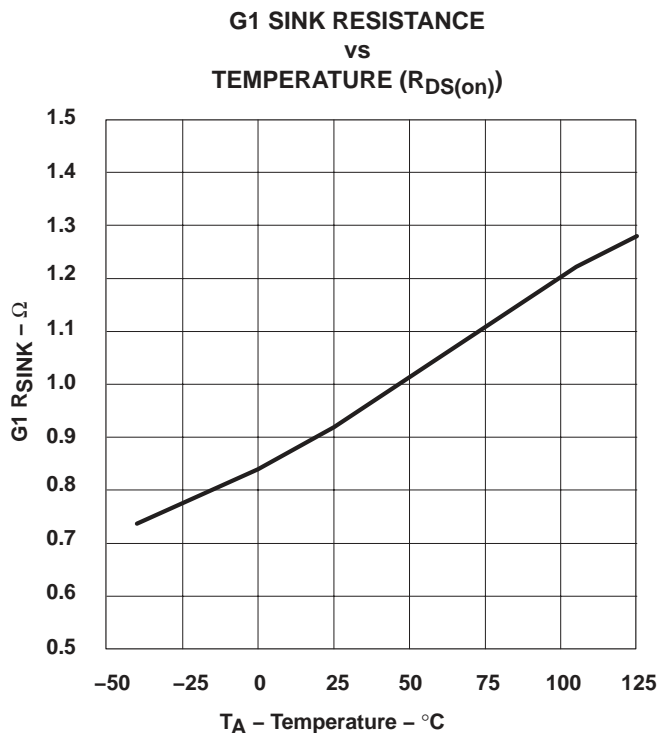

Figure 32

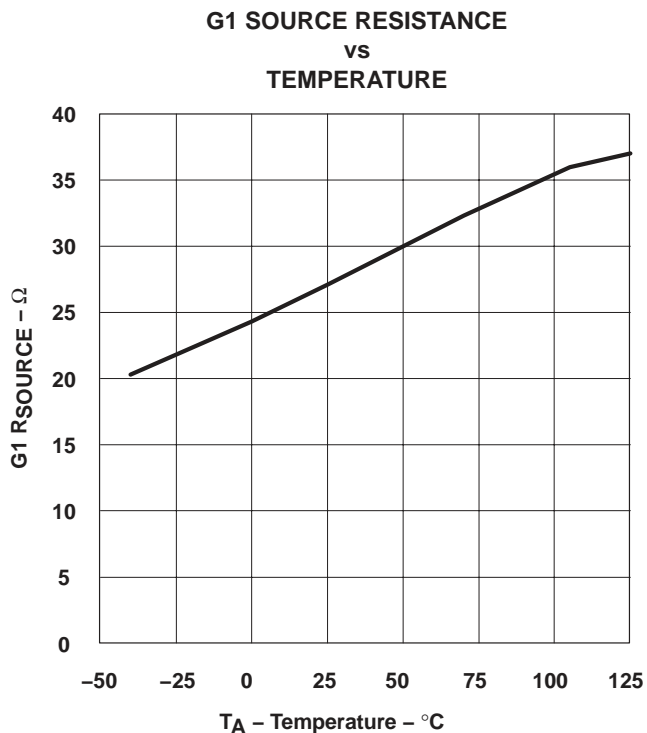
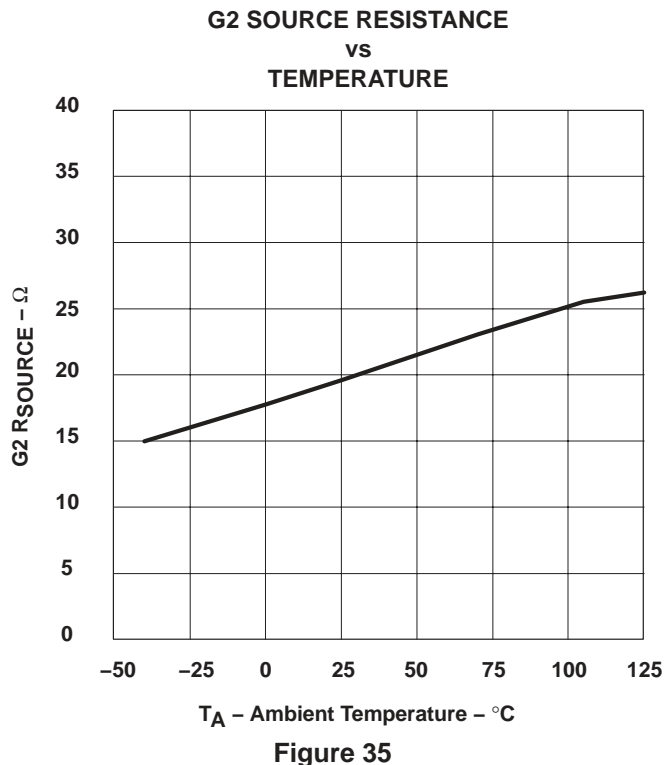
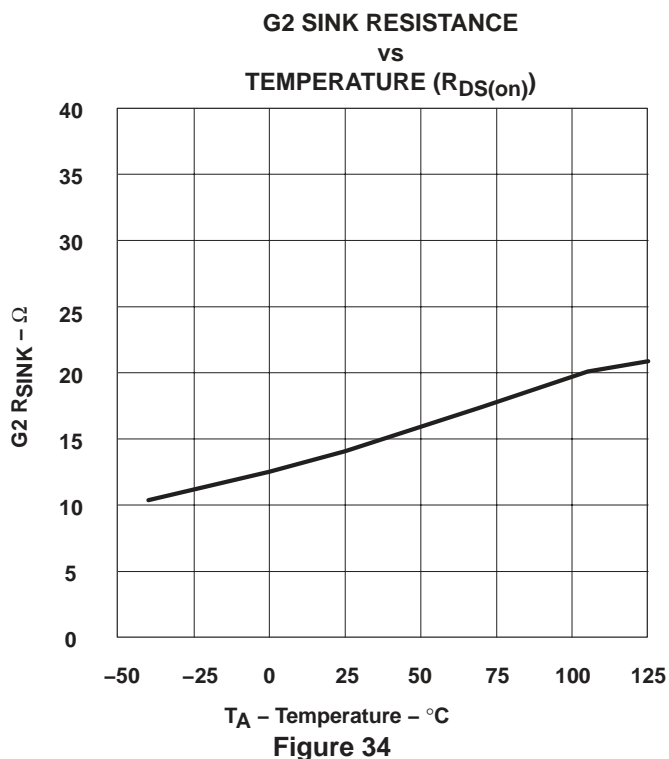

Figure 33

TYPICAL CHARACTERISTICS



RELATED PRODUCTS

PART NUMBER	DESCRIPTION	GATE DRIVE	PACKAGE
TPS2830/1	Fast synchronous buck MOSFET drivers with dead-time control	± 2.4 A	PowerPAD™ HTSSOP-14, SOIC-14
TPS2832/3	Fast synchronous buck MOSFET drivers with dead-time control	± 2.4 A	SOIC-8
TPS2834/5	Synchronous buck MOSFET drivers with dead-time control	± 2.4 A	PowerPAD™ HTSSOP-14, SOIC-14
TPS2836/7	Synchronous buck MOSFET drivers with dead-time control	± 2.4 A	SOIC-8
TPS2838/9	Synchronous buck MOSFET drivers with drive regulator	± 4 A	PowerPAD™ HTSSOP-16
TPS2848/9	Synchronous buck MOSFET drivers with drive regulator	± 4 A	PowerPAD™ HTSSOP-14
TPS40000/1/2/3	Low input voltage mode synchronous buck controller with predictive gate drive	± 1 A	PowerPAD™ MSOP-10

REFERENCES

1. Power Supply Design Seminar SEM-1400 Topic 2: *Design and Application Guide for High Speed MOSFET Gate Drive Circuits*, by Laszlo Balogh, Texas Instruments Literature Number SLUP169.
2. Power Supply Design Seminar SEM-1400 Topic 7: *Implication of Synchronous Rectifiers in Isolated, Single-Ended, Forward Converters*, by Christopher Bridge, Texas Instruments Literature Number SLUP175.
3. *12 V to 1.8 V, 20 A High-Efficiency Synchronous Buck Converter Using UCC27222 With Predictive Gate Drive™ Technology*, TI Literature Number SLUU140.

PACKAGING INFORMATION

Orderable Device	Status ⁽¹⁾	Package Type	Package Drawing	Pins	Package Qty	Eco Plan ⁽²⁾	Lead/Ball Finish	MSL Peak Temp ⁽³⁾
UCC27221PWP	ACTIVE	HTSSOP	PWP	14	90	Green (RoHS & no Sb/Br)	CU NIPDAU	Level-2-260C-1 YEAR
UCC27221PWPG4	ACTIVE	HTSSOP	PWP	14	90	Green (RoHS & no Sb/Br)	CU NIPDAU	Level-2-260C-1 YEAR
UCC27221PWPR	ACTIVE	HTSSOP	PWP	14	2000	Green (RoHS & no Sb/Br)	CU NIPDAU	Level-2-260C-1 YEAR
UCC27221PWPRG4	ACTIVE	HTSSOP	PWP	14	2000	Green (RoHS & no Sb/Br)	CU NIPDAU	Level-2-260C-1 YEAR
UCC27222PWP	ACTIVE	HTSSOP	PWP	14	90	Green (RoHS & no Sb/Br)	CU NIPDAU	Level-2-260C-1 YEAR
UCC27222PWPG4	ACTIVE	HTSSOP	PWP	14	90	Green (RoHS & no Sb/Br)	CU NIPDAU	Level-2-260C-1 YEAR
UCC27222PWPR	ACTIVE	HTSSOP	PWP	14	2000	Green (RoHS & no Sb/Br)	CU NIPDAU	Level-2-260C-1 YEAR
UCC27222PWPRG4	ACTIVE	HTSSOP	PWP	14	2000	Green (RoHS & no Sb/Br)	CU NIPDAU	Level-2-260C-1 YEAR

⁽¹⁾ The marketing status values are defined as follows:

ACTIVE: Product device recommended for new designs.

LIFEBUY: TI has announced that the device will be discontinued, and a lifetime-buy period is in effect.

NRND: Not recommended for new designs. Device is in production to support existing customers, but TI does not recommend using this part in a new design.

PREVIEW: Device has been announced but is not in production. Samples may or may not be available.

OBSOLETE: TI has discontinued the production of the device.

⁽²⁾ Eco Plan - The planned eco-friendly classification: Pb-Free (RoHS), Pb-Free (RoHS Exempt), or Green (RoHS & no Sb/Br) - please check <http://www.ti.com/productcontent> for the latest availability information and additional product content details.

TBD: The Pb-Free/Green conversion plan has not been defined.

Pb-Free (RoHS): TI's terms "Lead-Free" or "Pb-Free" mean semiconductor products that are compatible with the current RoHS requirements for all 6 substances, including the requirement that lead not exceed 0.1% by weight in homogeneous materials. Where designed to be soldered at high temperatures, TI Pb-Free products are suitable for use in specified lead-free processes.

Pb-Free (RoHS Exempt): This component has a RoHS exemption for either 1) lead-based flip-chip solder bumps used between the die and package, or 2) lead-based die adhesive used between the die and leadframe. The component is otherwise considered Pb-Free (RoHS compatible) as defined above.

Green (RoHS & no Sb/Br): TI defines "Green" to mean Pb-Free (RoHS compatible), and free of Bromine (Br) and Antimony (Sb) based flame retardants (Br or Sb do not exceed 0.1% by weight in homogeneous material)

⁽³⁾ MSL, Peak Temp. -- The Moisture Sensitivity Level rating according to the JEDEC industry standard classifications, and peak solder temperature.

Important Information and Disclaimer:The information provided on this page represents TI's knowledge and belief as of the date that it is provided. TI bases its knowledge and belief on information provided by third parties, and makes no representation or warranty as to the accuracy of such information. Efforts are underway to better integrate information from third parties. TI has taken and continues to take reasonable steps to provide representative and accurate information but may not have conducted destructive testing or chemical analysis on incoming materials and chemicals. TI and TI suppliers consider certain information to be proprietary, and thus CAS numbers and other limited information may not be available for release.

In no event shall TI's liability arising out of such information exceed the total purchase price of the TI part(s) at issue in this document sold by TI to Customer on an annual basis.

TAPE AND REEL BOX INFORMATION

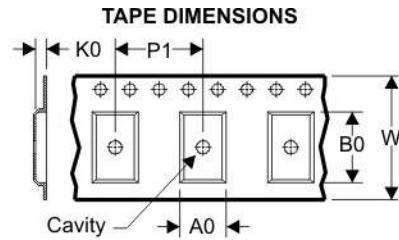
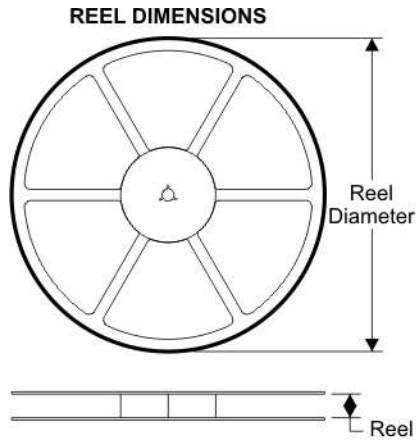

A0	Dimension designed to accommodate the component width
B0	Dimension designed to accommodate the component length
K0	Dimension designed to accommodate the component thickness
W	Overall width of the carrier tape
P1	Pitch between successive cavity centers

QUADRANT ASSIGNMENTS FOR PIN 1 ORIENTATION IN TAPE

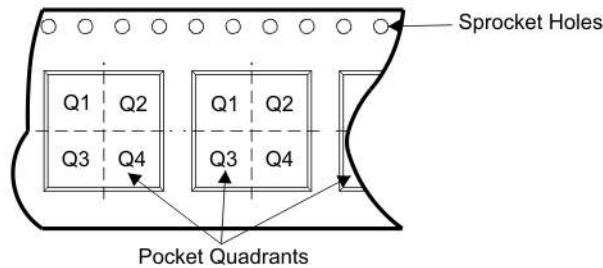

Device	Package	Pins	Site	Reel Diameter (mm)	Reel Width (mm)	A0 (mm)	B0 (mm)	K0 (mm)	P1 (mm)	W (mm)	Pin1 Quadrant
UCC27221PWPR	PWP	14	SITE 60	330	12	6.67	5.4	1.6	8	12	Q1
UCC27222PWPR	PWP	14	SITE 60	330	12	6.67	5.4	1.6	8	12	Q1

TAPE AND REEL BOX DIMENSIONS



Device	Package	Pins	Site	Length (mm)	Width (mm)	Height (mm)
UCC27221PWPR	PWP	14	SITE 60	346.0	346.0	29.0
UCC27222PWPR	PWP	14	SITE 60	346.0	346.0	29.0

PWP (R-PDSO-G**) 20 PIN SHOWN

PowerPAD™ PLASTIC SMALL-OUTLINE PACKAGE

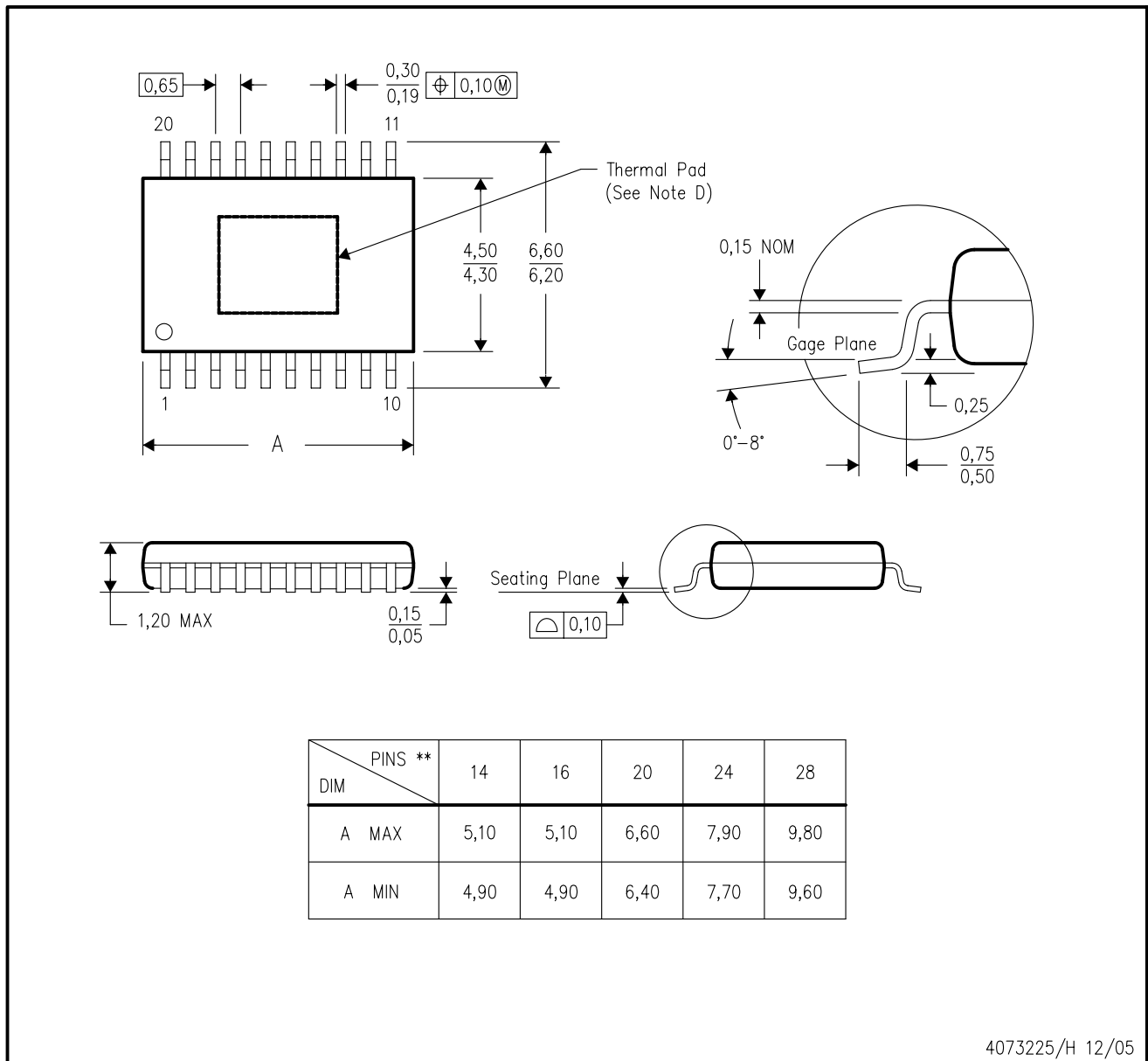

4073225/H 12/05

- NOTES:
- A. All linear dimensions are in millimeters.
 - B. This drawing is subject to change without notice.
 - C. Body dimensions do not include mold flash or protrusions. Mold flash and protrusion shall not exceed 0.15 per side.
 - D. This package is designed to be soldered to a thermal pad on the board. Refer to Technical Brief, PowerPad Thermally Enhanced Package, Texas Instruments Literature No. SLMA002 for information regarding recommended board layout. This document is available at www.ti.com <<http://www.ti.com>>.
 - E. Falls within JEDEC MO-153

PowerPAD is a trademark of Texas Instruments.

THERMAL INFORMATION

This PowerPAD™ package incorporates an exposed thermal pad that is designed to be attached directly to an external heatsink. The thermal pad must be soldered directly to the printed circuit board (PCB). After soldering, the PCB can be used as a heatsink. In addition, through the use of thermal vias, the thermal pad can be attached directly to the appropriate copper plane shown in the electrical schematic for the device, or alternatively, can be attached to a special heatsink structure designed into the PCB. This design optimizes the heat transfer from the integrated circuit (IC).

For additional information on the PowerPAD package and how to take advantage of its heat dissipating abilities, refer to Technical Brief, PowerPAD Thermally Enhanced Package, Texas Instruments Literature No. SLMA002 and Application Brief, PowerPAD Made Easy, Texas Instruments Literature No. SLMA004. Both documents are available at www.ti.com.

The exposed thermal pad dimensions for this package are shown in the following illustration.

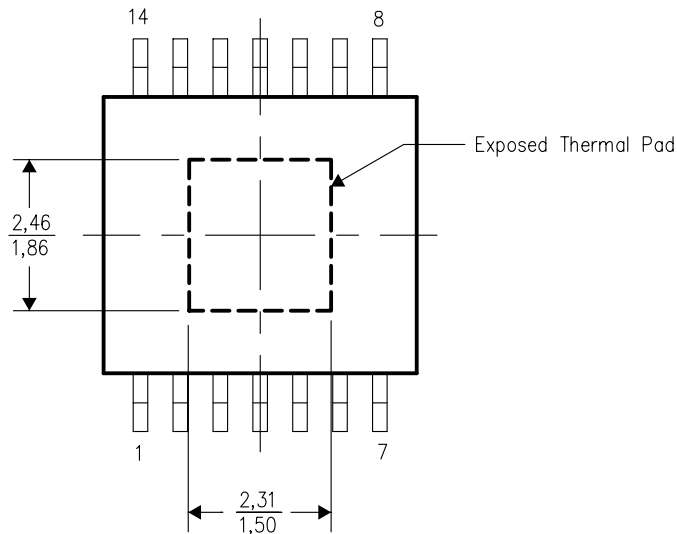

Top View

NOTE: All linear dimensions are in millimeters

Exposed Thermal Pad Dimensions

PWP (R-PDSO-G14) PowerPAD™

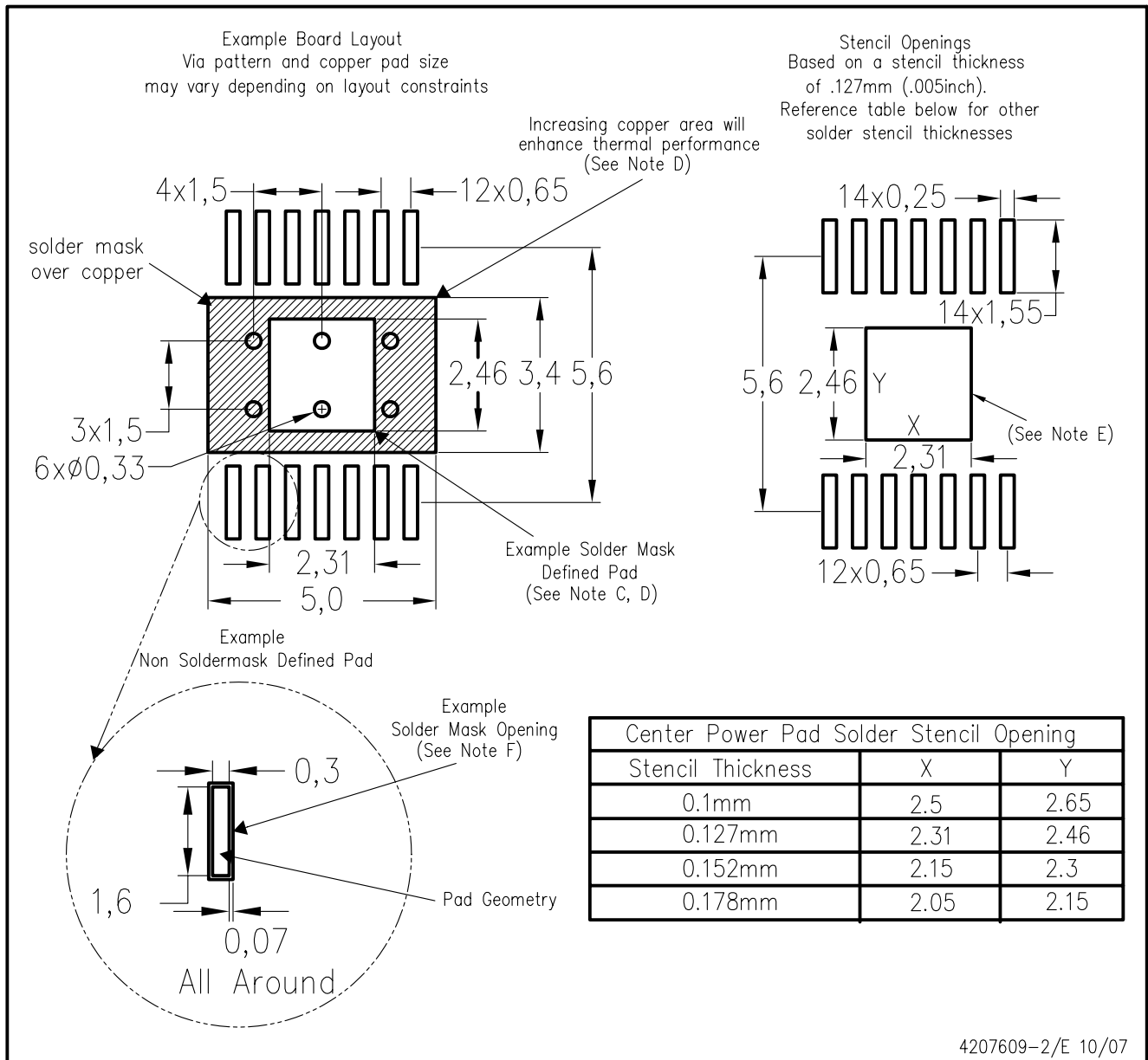

- NOTES:
- A. All linear dimensions are in millimeters.
 - B. This drawing is subject to change without notice.
 - C. Customers should place a note on the circuit board fabrication drawing not to alter the center solder mask defined pad.
 - D. This package is designed to be soldered to a thermal pad on the board. Refer to Technical Brief, PowerPad Thermally Enhanced Package, Texas Instruments Literature No. SLMA002, SLMA004, and also the Product Data Sheets for specific thermal information, via requirements, and recommended board layout. These documents are available at www.ti.com <<http://www.ti.com>>. Publication IPC-7351 is recommended for alternate designs.
 - E. Laser cutting apertures with trapezoidal walls and also rounding corners will offer better paste release. Customers should contact their board assembly site for stencil design recommendations. Example stencil design based on a 50% volumetric metal load solder paste. Refer to IPC-7525 for other stencil recommendations.
 - F. Customers should contact their board fabrication site for solder mask tolerances between and around signal pads.

PowerPAD is a trademark of Texas Instruments.

IMPORTANT NOTICE

Texas Instruments Incorporated and its subsidiaries (TI) reserve the right to make corrections, modifications, enhancements, improvements, and other changes to its products and services at any time and to discontinue any product or service without notice. Customers should obtain the latest relevant information before placing orders and should verify that such information is current and complete. All products are sold subject to TI's terms and conditions of sale supplied at the time of order acknowledgment.

TI warrants performance of its hardware products to the specifications applicable at the time of sale in accordance with TI's standard warranty. Testing and other quality control techniques are used to the extent TI deems necessary to support this warranty. Except where mandated by government requirements, testing of all parameters of each product is not necessarily performed.

TI assumes no liability for applications assistance or customer product design. Customers are responsible for their products and applications using TI components. To minimize the risks associated with customer products and applications, customers should provide adequate design and operating safeguards.

TI does not warrant or represent that any license, either express or implied, is granted under any TI patent right, copyright, mask work right, or other TI intellectual property right relating to any combination, machine, or process in which TI products or services are used. Information published by TI regarding third-party products or services does not constitute a license from TI to use such products or services or a warranty or endorsement thereof. Use of such information may require a license from a third party under the patents or other intellectual property of the third party, or a license from TI under the patents or other intellectual property of TI.

Reproduction of TI information in TI data books or data sheets is permissible only if reproduction is without alteration and is accompanied by all associated warranties, conditions, limitations, and notices. Reproduction of this information with alteration is an unfair and deceptive business practice. TI is not responsible or liable for such altered documentation. Information of third parties may be subject to additional restrictions.

Resale of TI products or services with statements different from or beyond the parameters stated by TI for that product or service voids all express and any implied warranties for the associated TI product or service and is an unfair and deceptive business practice. TI is not responsible or liable for any such statements.

TI products are not authorized for use in safety-critical applications (such as life support) where a failure of the TI product would reasonably be expected to cause severe personal injury or death, unless officers of the parties have executed an agreement specifically governing such use. Buyers represent that they have all necessary expertise in the safety and regulatory ramifications of their applications, and acknowledge and agree that they are solely responsible for all legal, regulatory and safety-related requirements concerning their products and any use of TI products in such safety-critical applications, notwithstanding any applications-related information or support that may be provided by TI. Further, Buyers must fully indemnify TI and its representatives against any damages arising out of the use of TI products in such safety-critical applications.

TI products are neither designed nor intended for use in military/aerospace applications or environments unless the TI products are specifically designated by TI as military-grade or "enhanced plastic." Only products designated by TI as military-grade meet military specifications. Buyers acknowledge and agree that any such use of TI products which TI has not designated as military-grade is solely at the Buyer's risk, and that they are solely responsible for compliance with all legal and regulatory requirements in connection with such use.

TI products are neither designed nor intended for use in automotive applications or environments unless the specific TI products are designated by TI as compliant with ISO/TS 16949 requirements. Buyers acknowledge and agree that, if they use any non-designated products in automotive applications, TI will not be responsible for any failure to meet such requirements.

Following are URLs where you can obtain information on other Texas Instruments products and application solutions:

Products		Applications	
Amplifiers	amplifier.ti.com	Audio	www.ti.com/audio
Data Converters	dataconverter.ti.com	Automotive	www.ti.com/automotive
DSP	dsp.ti.com	Broadband	www.ti.com/broadband
Interface	interface.ti.com	Digital Control	www.ti.com/digitalcontrol
Logic	logic.ti.com	Military	www.ti.com/military
Power Mgmt	power.ti.com	Optical Networking	www.ti.com/opticalnetwork
Microcontrollers	microcontroller.ti.com	Security	www.ti.com/security
RFID	www.ti-rfid.com	Telephony	www.ti.com/telephony
Low Power Wireless	www.ti.com/lpw	Video & Imaging	www.ti.com/video
		Wireless	www.ti.com/wireless

Mailing Address: Texas Instruments, Post Office Box 655303, Dallas, Texas 75265
Copyright © 2007, Texas Instruments Incorporated