

## Dual high-side switch (7.0 mOhm)

The 07XS3200 is one in a family of SMARTMOS devices designed for low-voltage automotive lighting applications. Two low  $R_{DS(on)}$  MOSFETs (dual 7.0 m $\Omega$ ) can control two separate 55 W bulbs, and/or Xenon modules, and/or LEDs.

Programming, control and diagnostics are accomplished using a 16-bit SPI interface. Its output with selectable slew rate improves electromagnetic compatibility (EMC) behavior. Additionally, each output has its own parallel input or SPI control for pulse-width modulation (PWM) control if desired. The 07XS3200 allows the user to program via the SPI, the fault current trip levels and duration of acceptable lamp inrush. The device has Fail-safe mode to provide fail-safe functionality of the outputs in case of MCU damaged.

The 07XS3200 is packaged in a Pb-free power-enhanced 32 pins SOIC package with exposed pad.

### Features

- Dual 7.0 m $\Omega$  max high-side switch (at 25 °C)
- Operating voltage range of 6.0 to 20 V with sleep current < 5.0  $\mu$ A, extended mode from 4.0 V to 28 V
- 8.0 MHz 16-bit 3.3 V and 5.0 V SPI control and status reporting with daisy chain capability
- PWM module using external clock or calibratable internal oscillator with programmable outputs delay management
- Smart overcurrent shutdown compliant to huge inrush current, severe short-circuit, overtemperature protections with time limited autoretry, and Fail-safe mode, in case of MCU damage
- Output off or on openload detection compliant to bulbs or LEDs and short to battery detection. Analog current feedback with selectable ratio and board temperature feedback.



### Applications

- Low-voltage automotive lighting
  - Halogen bulbs
  - Incandescent bulbs
  - HID Xenon ballasts
- Low-voltage industrial lighting

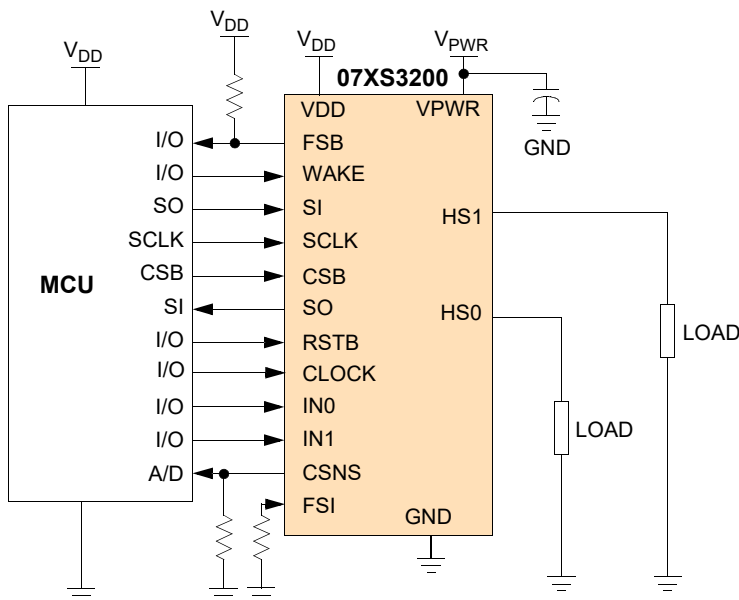

Figure 1. 07XS3200 simplified application diagram

# Table of contents

1	Orderable parts	3
2	Internal block diagram	4
3	Pin connections	5
3.1	Pinout diagram	5
3.2	Pin definitions	5
4	Electrical characteristics	7
4.1	Maximum ratings	7
4.2	Static electrical characteristics	9
4.3	Dynamic electrical characteristics	13
4.4	Timing diagrams	17
5	Functional description	20
5.1	Introduction	20
5.2	Functional pin description	20
5.3	Functional internal block description	22
6	Functional device operation	23
6.1	SPI protocol description	23
6.2	Operational modes	23
6.3	Protection and diagnostic features	28
6.4	Logic commands and registers	32
7	Typical applications	41
8	Packaging	42
8.1	Soldering information	42
8.2	Package dimensions	42
9	Revision history	46

# 1 Orderable parts

Table 1. Orderable part variations

Part number	Temperature (T <sub>A</sub> )	Package
MC07XS3200EK <sup>(1)</sup>	-40 °C to 125 °C	32-pin SOIC

Notes

1. To order parts in tape and reel, add the R2 suffix to the part number.

## 2 Internal block diagram

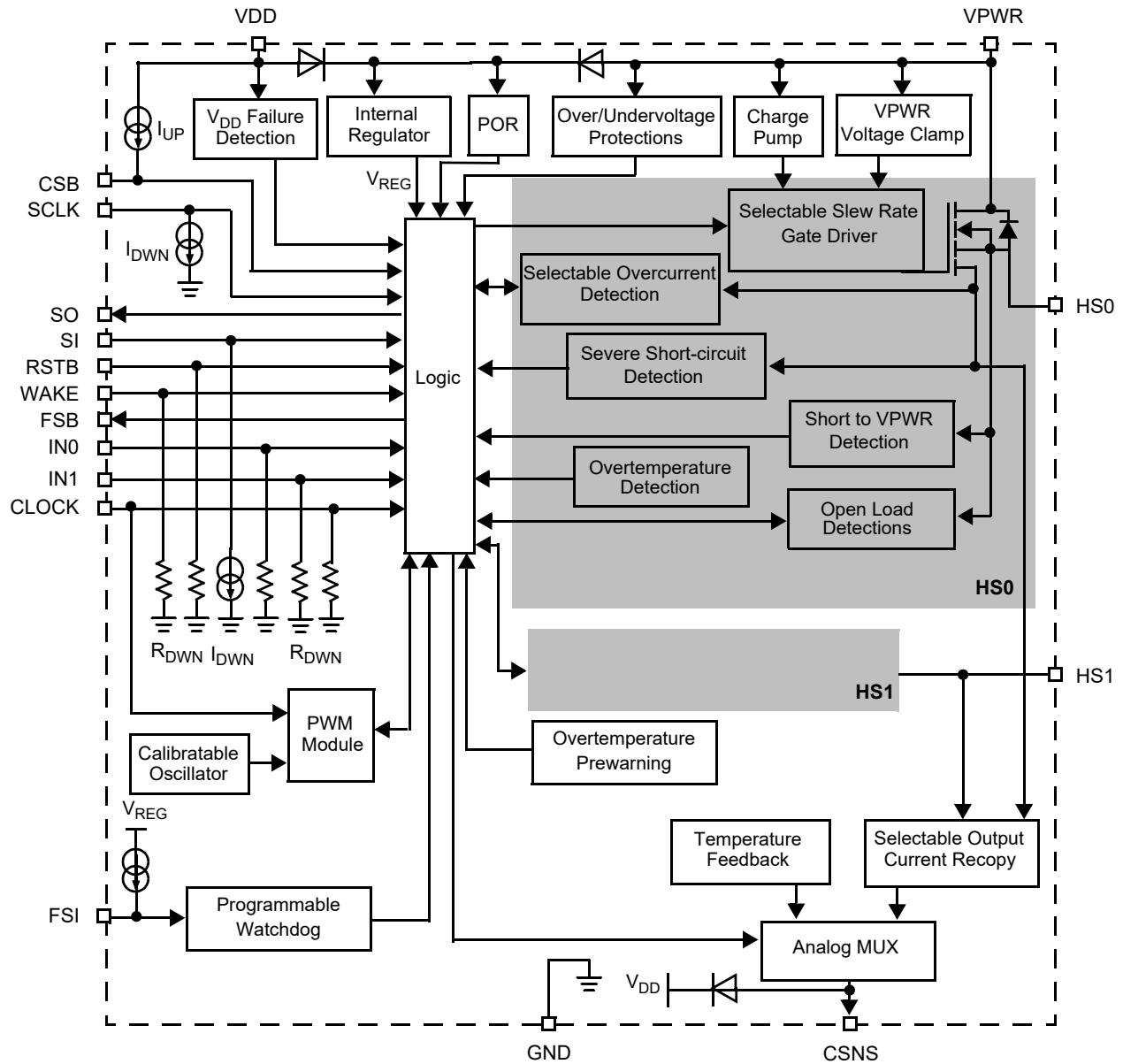

Figure 2. 07XS3200 simplified internal block diagram

## 3 Pin connections

### 3.1 Pinout diagram

Transparent top view

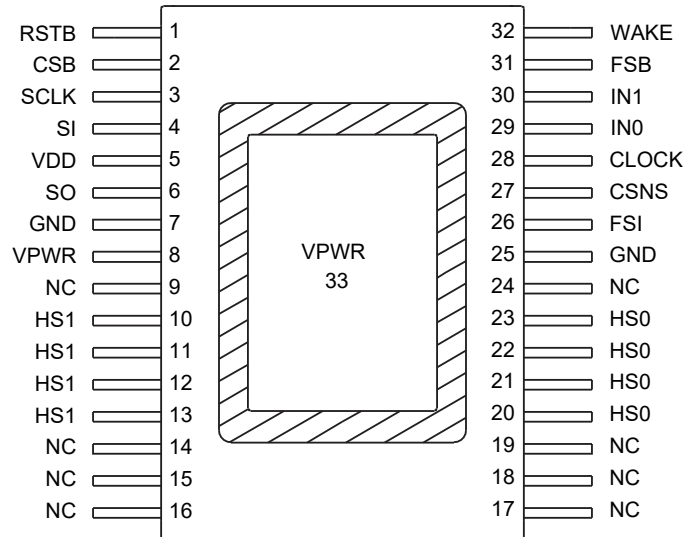

Figure 3. 07XS3200 pin connection

### 3.2 Pin definitions

A functional description of each pin can be found in the functional pin description section beginning on page 20.

Table 2. 07XS3200 pin definitions

Pin number	Pin name	Pin function	Formal name	Definition
1	RSTB	Input	Reset (active low)	This input pin is used to initialize the device configuration and fault registers, as well as place the device in a low current Sleep mode.
2	CSB	Input	Chip select (active low)	This input pin is connected to a chip select output of a master microcontroller (MCU).
3	SCLK	Input	Serial clock	This input pin is connected to the MCU providing the required bit shift clock for SPI communication.
4	SI	Input	Serial input	This is a command data input pin connected to the SPI Serial Data Output of the MCU or to the SO pin of the previous device of a daisy chain of devices.
5	VDD	Input	Digital drain voltage (power)	This is an external voltage input pin used to supply power to the SPI circuit.
6	SO	Output	Serial output	This output pin is connected to the SPI serial data input pin of the MCU or to the SI pin of the next device of a daisy chain of devices.
7, 25	GND	Ground	Ground	Those pins are the ground for the logic and analog circuitry of the device. These pins must be shorted to board level.
8	VPWR	Power	Positive power supply	Pin 8 is a positive supply for quiet and accurate control. Pin 33 is the main power supply for the high current switch. These pins must be shorted at board level. Connecting a heatsink to pin 33 guarantees optimal heat-evacuation properties.
9, 14 to 19, 24	NC	—	No connect	These pins are no connected pins. It is recommended to connect these pins to ground.

**Table 2. 07XS3200 pin definitions (continued)**

Pin number	Pin name	Pin function	Formal name	Definition
10, 11, 12, 13	HS1	Output	High-side output	Protected 7.0 mΩ high-side power output pin to the load. Those pins must be shorted at board level.
20, 21, 22, 23	HS0	Output	High-side output	Protected 7.0 mΩ high-side power output pin to the load. Those pins must be shorted at board level.
26	FSI	Input	Fail-safe input	The value of the resistance connected between this pin and ground determines the state of the outputs after a watchdog timeout occurs.
27	CSNS	Output	Output current Monitoring	This pin is used to output a current proportional to the designated HS0-1 output.
28	CLOCK	Input	Reference clock	This pin is used to apply a reference clock used to control the outputs in PWM mode through embedded PWM module.
29	IN0	Input	Direct input 0	This input pin is used to directly control the output HS0.
30	IN1	Input	Direct input 1	This input pin is used to directly control the output HS1.
31	FSB	Output	Fault status (active low)	This is an open drain configured output requiring an external pull-up resistor to VDD for fault reporting.
32	WAKE	Input	Wake	This pin is used to input a Logic [1] signal so as to enable the watchdog timer function.

# 4 Electrical characteristics

## 4.1 Maximum ratings

**Table 3. Maximum ratings**

All voltages are with respect to ground unless otherwise noted. Exceeding these ratings may cause a malfunction or permanent damage to the device.

Symbol	Ratings	Value	Unit	Notes
<b>Electrical ratings</b>				
$V_{PWR(SS)}$	$V_{PWR}$ supply voltage range <ul style="list-style-type: none"> <li>• Load dump at 25 °C (400 ms)</li> <li>• Maximum operating voltage</li> <li>• Reverse battery</li> </ul>	41 28 -18	V	
$V_{DD}$	$V_{DD}$ supply voltage range	-0.3 to 5.5	V	
	Input/output voltage	-0.3 to $V_{DD}+0.3$	V	(5)
$I_{CL(WAKE)}$	WAKE input clamp current	2.5	mA	
$I_{CL(CSNS)}$	CSNS input clamp current	2.5	mA	
$V_{HS[0:1]}$	HS [0:1] voltage <ul style="list-style-type: none"> <li>• Positive</li> <li>• Negative</li> </ul>	41 -24	V	
$I_{HS[0:1]}$	Output current per channel <ul style="list-style-type: none"> <li>• Nominal continuous current</li> <li>• Short-circuit transient current</li> <li>• Reverse continuous current</li> </ul>	26 116 -26	A	(2)
$V_{PWR} - V_{HS}$	High-side breakdown voltage	47	V	
$E_{CL[0:1]}$	HS[0,1] output clamp energy using single pulse method	100	mJ	(3)
$V_{ESD1}$ $V_{ESD2}$ $V_{ESD3}$ $V_{ESD4}$	ESD voltage <ul style="list-style-type: none"> <li>• Human Body Model (HBM) for HS[0:1], <math>V_{PWR}</math> and GND</li> <li>• Human Body Model (HBM) for other pins</li> <li>• Charge Device Model (CDM)               <ul style="list-style-type: none"> <li>Corner pins (1, 27, 28, 57)</li> <li>All other pins</li> </ul> </li> </ul>	±8000 ±2000 ±750 ±500	V	(4)
<b>Thermal ratings</b>				
$T_A$ $T_J$	Operating temperature <ul style="list-style-type: none"> <li>• Ambient</li> <li>• Junction</li> </ul>	-40 to 125 -40 to 150	°C	
$T_{STG}$	Storage temperature	-55 to 150	°C	

**Notes**

- Continuous high-side output current rating so long as maximum junction temperature is not exceeded. Calculation of maximum output current using board thermal resistance is required.
- Active clamp energy using single-pulse method ( $L = 2.0$  mH,  $R_L = 0$   $\Omega$ ,  $V_{PWR} = 14$  V,  $T_J = 150$  °C initial).
- ESD testing is performed in accordance with the Human Body Model (HBM) ( $C_{ZAP} = 100$  pF,  $R_{ZAP} = 1500$   $\Omega$ ), the Machine Model (MM) ( $C_{ZAP} = 200$  pF,  $R_{ZAP} = 0$   $\Omega$ ), and the Charge Device Model (CDM), Robotic ( $C_{ZAP} = 4.0$  pF).
- Input/output pins are: IN[0:1], CLOCK, RSTB, FSI, CSNS, SI, SCLK, CSB, SO, FSB

**Table 3. Maximum ratings (continued)**

All voltages are with respect to ground unless otherwise noted. Exceeding these ratings may cause a malfunction or permanent damage to the device.

Symbol	Ratings	Value	Unit	Notes
<b>Thermal resistance</b>				
$R_{\theta JC}$ $R_{\theta JA}$	Thermal resistance • Junction to Case • Junction to Ambient	4.0 35	°C/W	(6)
$T_{SOLDER}$	Peak Pin Reflow Temperature During Solder Mounting	260	°C	(7)

**Notes**

6. Device mounted on a 2s2p test board per JEDEC JESD51-2. 20 °C/W of  $R_{\theta JA}$  can be reached in a real application case (4 layers board).
7. Pin soldering temperature limit is for 40 seconds maximum duration. Not designed for immersion soldering. Exceeding these limits may cause malfunction or permanent damage to the device.



## 4.2 Static electrical characteristics

**Table 4. Static electrical characteristics**

Characteristics noted under conditions  $6.0\text{ V} \leq V_{PWR} \leq 20\text{ V}$ ,  $3.0\text{ V} \leq V_{DD} \leq 5.5\text{ V}$ ,  $-40\text{ }^\circ\text{C} \leq T_A \leq 125\text{ }^\circ\text{C}$ ,  $\text{GND} = 0\text{ V}$ , unless otherwise noted. Typical values noted reflect the approximate parameter means at  $T_A = 25\text{ }^\circ\text{C}$  under nominal conditions, unless otherwise noted.

Symbol	Characteristic	Min	Typ	Max	Unit	Notes
<b>Power inputs</b>						
$V_{PWR}$	Battery supply voltage range <ul style="list-style-type: none"> <li>Fully operational</li> <li>Extended mode</li> </ul>	6.0 4.0	– –	20 28	V	(8)
$V_{PWR(\text{CLAMP})}$	Battery clamp voltage	41	47	53	V	(9)
$I_{PWR(\text{ON})}$	$V_{PWR}$ operating supply current <ul style="list-style-type: none"> <li>Outputs commanded ON, HS[0:1] open, IN[0:1] &gt; <math>V_{IH}</math></li> </ul>	–	6.5	20	mA	
$I_{PWR(\text{SBY})}$	$V_{PWR}$ supply current <ul style="list-style-type: none"> <li>Outputs commanded OFF, OFF openload detection disabled, HS[0:1] shorted to the ground with <math>V_{DD} = 5.5\text{ V}</math> WAKE &gt; <math>V_{IH}</math> or RSTB &gt; <math>V_{IH}</math> and IN[0:1] &lt; <math>V_{IL}</math></li> </ul>	–	6.5	7.5	mA	
$I_{PWR(\text{SLEEP})}$	Sleep state supply current $V_{PWR} = 12\text{ V}$ , RSTB = WAKE = CLOCK = IN[0:1] < $V_{IL}$ , HS[0:1] shorted to ground <ul style="list-style-type: none"> <li><math>T_A = 25\text{ }^\circ\text{C}</math></li> <li><math>T_A = 85\text{ }^\circ\text{C}</math></li> </ul>	– –	1.0 –	5.0 30	$\mu\text{A}$	
$V_{DD(\text{ON})}$	$V_{DD}$ supply voltage	3.0	–	5.5	V	
$I_{DD(\text{ON})}$	$V_{DD}$ supply current at $V_{DD} = 5.5\text{ V}$ <ul style="list-style-type: none"> <li>No SPI communication</li> <li>8.0 MHz SPI communication</li> </ul>	– –	1.6 5.0	2.2 –	mA	(10)
$I_{DD(\text{SLEEP})}$	$V_{DD}$ sleep state current at $V_{DD} = 5.5\text{ V}$	–	–	5.0	$\mu\text{A}$	
$V_{PWR(\text{OV})}$	Overvoltage shutdown threshold	28	32	36	V	
$V_{PWR(\text{OVHYS})}$	Overvoltage shutdown hysteresis	0.2	0.8	1.5	V	
$V_{PWR(\text{UV})}$	Undervoltage shutdown threshold	3.3	3.9	4.3	V	(11)
$V_{\text{SUPPLY}(\text{POR})}$	$V_{PWR}$ and $V_{DD}$ power-on reset threshold	0.5	–	0.9	$V_{PWR(\text{UV})}$	
$V_{PWR(\text{UV})\_UP}$	Recovery undervoltage threshold	3.4	4.1	4.5	V	
$V_{DD(\text{FAIL})}$	$V_{DD}$ supply failure threshold (for $V_{PWR} > V_{PWR(\text{UV})}$ )	2.2	2.5	2.8	V	

**Notes**

- In extended mode, the functionality is guaranteed but not the electrical parameters. From 4.0 V to 6.0 V voltage range, the device is only protected with the thermal shutdown detection.
- Measured with the outputs open.
- Typical value guaranteed per design.
- Output automatically recovers with time limited autoretry to instructed state when  $V_{PWR}$  voltage is restored to normal as long as the  $V_{PWR}$  degradation level did not go below the undervoltage power-on reset threshold. This applies to all internal device logic that is supplied by  $V_{PWR}$  and assumes that the external  $V_{DD}$  supply is within specification.

**Table 4. Static electrical characteristics (continued)**

Characteristics noted under conditions  $6.0\text{ V} \leq V_{PWR} \leq 20\text{ V}$ ,  $3.0\text{ V} \leq V_{DD} \leq 5.5\text{ V}$ ,  $-40\text{ }^\circ\text{C} \leq T_A \leq 125\text{ }^\circ\text{C}$ ,  $GND = 0\text{ V}$ , unless otherwise noted. Typical values noted reflect the approximate parameter means at  $T_A = 25\text{ }^\circ\text{C}$  under nominal conditions, unless otherwise noted.

Symbol	Characteristic	Min	Typ	Max	Unit	Notes
<b>Outputs HS0 TO HS1</b>						
$R_{DS\_01(on)}$	HS[0,1] output Drain-to-Source ON resistance ( $I_{HS} = 5.0\text{ A}$ , $T_A = 25\text{ }^\circ\text{C}$ ) <ul style="list-style-type: none"> <li><math>V_{PWR} = 4.5\text{ V}</math></li> <li><math>V_{PWR} = 6.0\text{ V}</math></li> <li><math>V_{PWR} = 10\text{ V}</math></li> <li><math>V_{PWR} = 13\text{ V}</math></li> </ul>	–	–	25.2	m $\Omega$	
$R_{DS\_01(on)}$	HS[0,1] output Drain-to-Source ON resistance ( $I_{HS} = 5.0\text{ A}$ , $T_A = 150\text{ }^\circ\text{C}$ ) <ul style="list-style-type: none"> <li><math>V_{PWR} = 4.5\text{ V}</math></li> <li><math>V_{PWR} = 6.0\text{ V}</math></li> <li><math>V_{PWR} = 10\text{ V}</math></li> <li><math>V_{PWR} = 13\text{ V}</math></li> </ul>	–	–	42.8	m $\Omega$	
$R_{SD\_01(on)}$	HS[0,1] output Source-to-Drain ON resistance ( $I_{HS} = -5.0\text{ A}$ , $V_{PWR} = -18\text{ V}$ ) <ul style="list-style-type: none"> <li><math>T_A = 25\text{ }^\circ\text{C}</math></li> <li><math>T_A = 150\text{ }^\circ\text{C}</math></li> </ul>	–	–	10.5	m $\Omega$	(12)
$R_{SHORT\_01}$	HS[0,1] maximum severe short-circuit impedance detection	21	47	75	m $\Omega$	(13)
OCHI1 OCHI2 OC1 OC2 OC3 OC4 OCLO4 OCLO3 OCLO2 OCLO1	HS[0,1] output overcurrent detection levels ( $6.0\text{ V} \leq V_{HS[0:1]} \leq 20\text{ V}$ )	89.9 67 48 42 35.2 28.8 21 13.3 11.3 7.4	114.8 83.7 61.2 53.2 44.6 36.4 26.6 18.4 14.2 9.3	139.8 100.4 74.4 64.4 54 44 32.1 23.5 17.1 11.2	A	
$C_{SR0}$ $C_{SR1}$	HS[0,1] current sense ratio ( $6.0\text{ V} \leq V_{HS[0:1]} \leq 20\text{ V}$ , $CSNS \leq 5.0\text{ V}$ ) <ul style="list-style-type: none"> <li><math>CSNS\_ratio\text{ bit} = 0</math></li> <li><math>CSNS\_ratio\text{ bit} = 1</math></li> </ul>	–	1/10700 1/63600	–	–	(14)

**Notes**

- Source-Drain ON resistance (reverse Drain-to-Source ON resistance) with negative polarity  $V_{PWR}$ .
- Short-circuit impedance calculated from HS[0:1] to GND pins. Value guaranteed per design.
- Current sense ratio =  $I_{CSNS} / I_{HS[0:1]}$

**Table 4. Static electrical characteristics (continued)**

Characteristics noted under conditions  $6.0\text{ V} \leq V_{PWR} \leq 20\text{ V}$ ,  $3.0\text{ V} \leq V_{DD} \leq 5.5\text{ V}$ ,  $-40\text{ }^\circ\text{C} \leq T_A \leq 125\text{ }^\circ\text{C}$ ,  $\text{GND} = 0\text{ V}$ , unless otherwise noted. Typical values noted reflect the approximate parameter means at  $T_A = 25\text{ }^\circ\text{C}$  under nominal conditions, unless otherwise noted.

Symbol	Characteristic	Min	Typ	Max	Unit	Notes
<b>Outputs HS0 TO HS1 (continued)</b>						
$C_{SR0\_ACC}$	HS[0,1] current sense ratio ( $C_{SR0}$ ) accuracy ( $6.0\text{ V} \leq V_{HS[0:1]} \leq 20\text{ V}$ ) 25 °C and 125 °C <ul style="list-style-type: none"> <li>• <math>I_{HS[0:1]} = 12.5\text{ A}</math></li> <li>• <math>I_{HS[0:1]} = 5.0\text{ A}</math></li> <li>• <math>I_{HS[0:1]} = 3.0\text{ A}</math></li> <li>• <math>I_{HS[0:1]} = 1.5\text{ A}</math></li> </ul> -40 °C <ul style="list-style-type: none"> <li>• <math>I_{HS[0:1]} = 12.5\text{ A}</math></li> <li>• <math>I_{HS[0:1]} = 5.0\text{ A}</math></li> <li>• <math>I_{HS[0:1]} = 3.0\text{ A}</math></li> <li>• <math>I_{HS[0:1]} = 1.5\text{ A}</math></li> </ul>	-13 -20 -25 -30	– – – –	13 20 26 30	%	
$C_{SR0\_ACC}$ (CAL)	HS[0,1] current recopy accuracy with one calibration point ( $6.0\text{ V} \leq V_{HS[0:1]} \leq 20\text{ V}$ ) <ul style="list-style-type: none"> <li>• <math>I_{HS[0:1]} = 5.0\text{ A}</math></li> </ul>	-5.0	–	5.0	%	(15)
$\Delta(C_{SR0})/\Delta(T)$	HS[0,1] $C_{SR0}$ current recopy temperature drift ( $6.0\text{ V} \leq V_{HS[0:1]} \leq 20\text{ V}$ ) <ul style="list-style-type: none"> <li>• <math>I_{HS[0:1]} = 5.0\text{ A}</math></li> </ul>	–	–	0.04	%/°C	(16)
$C_{SR1\_ACC}$	HS[0,1] current sense ratio ( $C_{SR1}$ ) accuracy ( $6.0\text{ V} \leq V_{HS[0:1]} \leq 20\text{ V}$ ) 25 °C and 125 °C <ul style="list-style-type: none"> <li>• <math>I_{HS[0:1]} = 12.5\text{ A}</math></li> <li>• <math>I_{HS[0:1]} = 75\text{ A}</math></li> </ul> -40 °C <ul style="list-style-type: none"> <li>• <math>I_{HS[0:1]} = 12.5\text{ A}</math></li> <li>• <math>I_{HS[0:1]} = 75\text{ A}</math></li> </ul>	-17 -15	– –	17 15	%	
$C_{SR1\_ACC}$ (CAL)	HS[0,1] current recopy accuracy with one calibration point ( $6.0\text{ V} \leq V_{HS[0:1]} \leq 20\text{ V}$ ) <ul style="list-style-type: none"> <li>• <math>I_{HS[0:1]} = 12.5\text{ A}</math></li> </ul>	-5.0	–	5.0	%	(15)
$V_{CL}(CSNS)$	Current sense clamp voltage <ul style="list-style-type: none"> <li>• CSNS Open; <math>I_{HS[0:1]} = 5.0\text{ A}</math> with <math>C_{SR0}</math> ratio</li> </ul>	$V_{DD}+0.25$	–	$V_{DD}+1.0$	V	
$I_{OLD}(OFF)$	OFF openload detection source current	30	–	100	μA	(17)
$V_{OLD}(THRES)$	OFF openload fault detection voltage threshold	2.0	3.0	4.0	V	
$I_{OLD}(ON)$	ON openload fault detection current threshold	80	330	660	mA	
$I_{OLD}(ON\_LED)$	ON openload fault detection current threshold with LED <ul style="list-style-type: none"> <li>• <math>V_{HS[0:1]} = V_{PWR} - 0.75\text{ V}</math></li> </ul>	2.5	5.0	10	mA	
$V_{OSD}(THRES)$	Output short to $V_{PWR}$ detection voltage threshold <ul style="list-style-type: none"> <li>• Output programmed OFF</li> </ul>	$V_{PWR}-1.2$	$V_{PWR}-0.8$	$V_{PWR}-0.4$	V	
$V_{CL}$	Output negative clamp voltage <ul style="list-style-type: none"> <li>• <math>0.5\text{ A} \leq I_{HS[0:1]} \leq 5.0\text{ A}</math>, output programmed OFF</li> </ul>	-22	–	-16	V	
$T_{SD}$	Output overtemperature shutdown for $4.5\text{ V} < V_{PWR} < 28\text{ V}$	155	175	195	°C	

**Notes**

15. Based on statistical analysis. It is not production tested.
16. Based on statistical data:  $\Delta(C_{SR0})/\Delta(T) = \{(\text{measured } I_{CSNS} \text{ at } T_1 - \text{measured } I_{CSNS} \text{ at } T_2) / \text{measured } I_{CSNS} \text{ at room}\} / \{T_1 - T_2\}$ . No production tested.
17. Output OFF openload detection current is the current required to flow through the load for the purpose of detecting the existence of an openload condition when the specific output is commanded OFF. Pull-up current is measured for  $V_{HS} = V_{OLD}(THRES)$

**Table 4. Static electrical characteristics (continued)**

Characteristics noted under conditions  $6.0\text{ V} \leq V_{PWR} \leq 20\text{ V}$ ,  $3.0\text{ V} \leq V_{DD} \leq 5.5\text{ V}$ ,  $-40\text{ }^\circ\text{C} \leq T_A \leq 125\text{ }^\circ\text{C}$ ,  $\text{GND} = 0\text{ V}$ , unless otherwise noted. Typical values noted reflect the approximate parameter means at  $T_A = 25\text{ }^\circ\text{C}$  under nominal conditions, unless otherwise noted.

Symbol	Characteristic	Min	Typ	Max	Unit	Notes
<b>Control interface</b>						
$V_{IH}$	Input logic high voltage	2.0	–	$V_{DD}+0.3$	V	(18)
$V_{IL}$	Input logic low voltage	-0.3	–	0.8	V	(18)
$I_{DWN}$	Input logic pull-down current (SCLK, SI)	5.0	–	20	$\mu\text{A}$	(21)
$I_{UP}$	Input logic pull-up current (CSB)	5.0	–	20	$\mu\text{A}$	(22)
$C_{SO}$	SO, FSB tri-state capacitance	–	–	20	pF	(19)
$R_{DWN}$	Input logic pull-down resistor (RSTB, WAKE, CLOCK and IN[0:1])	125	250	500	$\text{k}\Omega$	
$C_{IN}$	Input capacitance	–	4.0	12	pF	(19)
$V_{CL(WAKE)}$	Wake input clamp voltage • $I_{CL(WAKE)} < 2.5\text{ mA}$	18	25	32	V	(20)
$V_{F(WAKE)}$	Wake input forward voltage • $I_{CL(WAKE)} = -2.5\text{ mA}$	-2.0	–	-0.3	V	
$V_{SOH}$	SO high state output voltage • $I_{OH} = 1.0\text{ mA}$	$V_{DD}-0.4$	–	–	V	
$V_{SOL}$	SO and FSB low state output voltage • $I_{OL} = -1.0\text{ mA}$	–	–	0.4	V	
$I_{SO(LEAK)}$	SO, CSNS and FSB tri-state leakage current • $\text{CSB} = V_{IH}$ and $0\text{ V} \leq V_{SO} \leq V_{DD}$ , or $\text{FSB} = 5.5\text{ V}$ , or $\text{CSNS} = 0.0\text{ V}$	-2.0	0.0	2.0	$\mu\text{A}$	
RFS	FSI external pull-down resistance • Watchdog disabled • Watchdog enabled	– 10	0.0 Infinite	1.0 –	$\text{k}\Omega$	(23)

**Notes**

18. Upper and lower logic threshold voltage range applies to SI, CSB, SCLK, FSB, IN[0:1], CLOCK and WAKE input signals. The WAKE and RSTB signals may be supplied by a derived voltage referenced to  $V_{PWR}$ .
19. Input capacitance of SI, CSB, SCLK, RSTB, IN[0:1], CLOCK and WAKE. This parameter is guaranteed by process monitoring but is not production tested.
20. The current must be limited by a series resistance when using voltages  $> 7.0\text{ V}$ .
21. Pull-down current is with  $V_{SI} \geq 1.0\text{ V}$  and  $V_{SCLK} \geq 1.0\text{ V}$ .
22. Pull-up current is with  $V_{CSB} \leq 2.0\text{ V}$ . CSB has an active internal pull-up to  $V_{DD}$ .
23. In Fail-safe HS[0:1] depends respectively on IN[0:1]. FSI has an active internal pull-up to  $V_{REG} \sim 3.0\text{ V}$ .

## 4.3 Dynamic electrical characteristics

**Table 5. Dynamic electrical characteristics**

Characteristics noted under conditions  $6.0\text{ V} \leq V_{PWR} \leq 20\text{ V}$ ,  $3.0\text{ V} \leq V_{DD} \leq 5.5\text{ V}$ ,  $-40\text{ }^\circ\text{C} \leq T_A \leq 125\text{ }^\circ\text{C}$ ,  $\text{GND} = 0\text{ V}$  unless otherwise noted. Typical values noted reflect the approximate parameter means at  $T_A = 25\text{ }^\circ\text{C}$  under nominal conditions unless otherwise noted.

Symbol	Characteristic	Min	Typ	Max	Unit	Notes
<b>Power output timing HS0 TO HS1</b>						
SR <sub>R_00</sub>	Output rising medium slew rate (medium speed slew rate / SR[1:0] = 00) • V <sub>PWR</sub> = 14 V	0.15	0.3	0.6	V/μs	(24)
SR <sub>R_01</sub>	Output rising slow slew rate (low speed slew rate / SR[1:0] = 01) • V <sub>PWR</sub> = 14 V	0.07	0.15	0.3	V/μs	(24)
SR <sub>R_10</sub>	Output falling fast slew rate (high speed slew rate / SR[1:0] = 10) • V <sub>PWR</sub> = 14 V	0.3	0.6	1.2	V/μs	(24)
SR <sub>F_00</sub>	Output falling medium slew rate (medium speed slew rate / SR[1:0] = 00) • V <sub>PWR</sub> = 14 V	0.15	0.3	0.6	V/μs	(24)
SR <sub>F_01</sub>	Output falling slow slew rate (low speed slew rate / SR[1:0] = 01) • V <sub>PWR</sub> = 14 V	0.07	0.15	0.3	V/μs	(24)
SR <sub>F_10</sub>	Output rising fast slew rate (high speed slew rate / SR[1:0] = 10) • V <sub>PWR</sub> = 14 V	0.3	0.6	1.2	V/μs	(24)
t <sub>DLY_12</sub>	HS[0:1] outputs turn-on and off delay time V <sub>PWR</sub> = 14 V for medium speed slew rate (SR[1:0] = 00) • t <sub>DLY(ON)</sub> • t <sub>DLY(OFF)</sub>	90 40	135 70	180 100	μs	(25) (26)
ΔSR	Driver output matching slew rate (SR <sub>R</sub> / SR <sub>F</sub> ) • V <sub>PWR</sub> = 14 V at 25 °C and for medium speed slew rate (SR[1:0] = 00)	0.8	1.0	1.2		
Δt <sub>RF_01</sub>	HS[0:1] driver output matching time (t <sub>DLY(ON)</sub> - t <sub>DLY(OFF)</sub> ) • V <sub>PWR</sub> = 14 V, f <sub>PWM</sub> = 240 Hz, PWM duty cycle = 50%, at 25 °C for medium speed slew rate (SR[1:0] = 00)	25	60	95	μs	
t <sub>FAULT</sub>	Fault detection blanking time	1.0	5.0	20	μs	(27)
t <sub>DETECT</sub>	Output shutdown delay time	–	7.0	30	μs	(28)
t <sub>CNSVAL</sub>	CSNS valid time	–	70	100	μs	(29)
t <sub>WDTO</sub>	Watchdog timeout	217	310	400	ms	(30)
T <sub>OLLED</sub>	ON openload fault cyclic detection period with LED • Internal clock (PWM_en bit = 1 & CLOCK_Set = 1) • External clock (PWM_en bit = 1 & CLOCK_Set = 0)	6.4 -	8.3 PWM period	12 -	ms	

### Notes

- Rise and fall slew rates measured across a 5.0 Ω resistive load at high-side output = 30% to 70% (see Figure 4, page 17).
- Turn-on delay time measured from rising edge of any signal (IN[0:1] and CSB) that would turn the output ON to  $V_{HS[0:1]} = V_{PWR} / 2$  with  $R_L = 5.0\text{ } \Omega$  resistive load.
- Turn-off delay time measured from falling edge of any signal (IN[0:1] and CSB) that would turn the output OFF to  $V_{HS[0:1]} = V_{PWR} / 2$  with  $R_L = 5.0\text{ } \Omega$  resistive load.
- Time necessary to report the fault to FSB pin.
- Time necessary to switch-off the output in case of OT or OC or SC or UV fault detection (from negative edge of FSB pin to HS voltage = 50% of  $V_{PWR}$ ).
- Time necessary for CSNS to be within ±5% of the targeted value (from HS voltage = 50% of  $V_{PWR}$  to ±5% of the targeted CSNS value).
- For FSI open, the watchdog timeout delay measured from the rising edge of RSTB, to HS[0,1] output state depend on the corresponding input command.

**Table 5. Dynamic electrical characteristics (continued)**

Characteristics noted under conditions  $6.0\text{ V} \leq V_{\text{PWR}} \leq 20\text{ V}$ ,  $3.0\text{ V} \leq V_{\text{DD}} \leq 5.5\text{ V}$ ,  $-40\text{ }^\circ\text{C} \leq T_{\text{A}} \leq 125\text{ }^\circ\text{C}$ ,  $\text{GND} = 0\text{ V}$  unless otherwise noted. Typical values noted reflect the approximate parameter means at  $T_{\text{A}} = 25\text{ }^\circ\text{C}$  under nominal conditions unless otherwise noted.

Symbol	Characteristic	Min	Typ	Max	Unit	Notes
<b>Power output timing HS0 TO HS1 (continued)</b>						
$t_{\text{OC1\_00}}$	HS[0,1] output overcurrent time step OC[1:0] = 00 (slow by default)	4.40	6.30	8.02	ms	
$t_{\text{OC2\_00}}$		1.62	2.32	3.00		
$t_{\text{OC3\_00}}$		2.10	3.00	3.90		
$t_{\text{OC4\_00}}$		2.88	4.12	5.36		
$t_{\text{OC5\_00}}$		4.58	6.56	8.54		
$t_{\text{OC6\_00}}$		10.16	14.52	18.88		
$t_{\text{OC7\_00}}$		73.2	104.6	134.0		
$t_{\text{OC1\_01}}$	OC[1:0]=01 (fast)	1.10	1.57	2.00		
$t_{\text{OC2\_01}}$		0.40	0.58	0.75		
$t_{\text{OC3\_01}}$		0.52	0.75	0.98		
$t_{\text{OC4\_01}}$		0.72	1.03	1.34		
$t_{\text{OC5\_01}}$		1.14	1.64	2.13		
$t_{\text{OC6\_01}}$		2.54	3.63	4.72		
$t_{\text{OC7\_01}}$		18.2	26.1	34.0		
$t_{\text{OC1\_10}}$	OC[1:0]=10 (medium)	2.20	3.15	4.01		
$t_{\text{OC2\_10}}$		0.81	1.16	1.50		
$t_{\text{OC3\_10}}$		1.05	1.50	1.95		
$t_{\text{OC4\_10}}$		1.44	2.06	2.68		
$t_{\text{OC5\_10}}$		2.29	3.28	4.27		
$t_{\text{OC6\_10}}$		5.08	7.26	9.44		
$t_{\text{OC7\_10}}$		36.6	52.3	68.0		
$t_{\text{OC1\_11}}$	OC[1:0]=11 (very slow)	8.8	12.6	16.4		
$t_{\text{OC2\_11}}$		3.2	4.6	21.4		
$t_{\text{OC3\_11}}$		4.2	6.0	7.8		
$t_{\text{OC4\_11}}$		5.7	8.2	10.7		
$t_{\text{OC5\_11}}$		9.1	13.1	17.0		
$t_{\text{OC6\_11}}$		20.3	29.0	37.7		
$t_{\text{OC7\_11}}$		146.4	209.2	272.0		
$t_{\text{BC1\_00}}$	HS[0,1] bulb cooling time step CB[1:0] = 00 or 11 (medium)	242	347	452	ms	
$t_{\text{BC2\_00}}$		126	181	236		
$t_{\text{BC3\_00}}$		140	200	260		
$t_{\text{BC4\_00}}$		158	226	294		
$t_{\text{BC5\_00}}$		181	259	337		
$t_{\text{BC6\_00}}$		211	302	393		
$t_{\text{BC1\_01}}$	CB[1:0] = 01 (fast)	121	173	226		
$t_{\text{BC2\_01}}$		63	90	118		
$t_{\text{BC3\_01}}$		70	100	130		
$t_{\text{BC4\_01}}$		79	113	147		
$t_{\text{BC5\_01}}$		90	129	169		
$t_{\text{BC6\_01}}$		105	151	197		
$t_{\text{BC1\_10}}$	CB[1:0] = 10 (slow)	484	694	1904		
$t_{\text{BC2\_10}}$		252	362	472		
$t_{\text{BC3\_10}}$		280	400	520		
$t_{\text{BC4\_10}}$		316	452	588		
$t_{\text{BC5\_10}}$		362	518	674		
$t_{\text{BC6\_10}}$		422	604	786		

**Table 5. Dynamic electrical characteristics (continued)**

Characteristics noted under conditions  $6.0\text{ V} \leq V_{\text{PWR}} \leq 20\text{ V}$ ,  $3.0\text{ V} \leq V_{\text{DD}} \leq 5.5\text{ V}$ ,  $-40\text{ }^\circ\text{C} \leq T_{\text{A}} \leq 125\text{ }^\circ\text{C}$ ,  $\text{GND} = 0\text{ V}$  unless otherwise noted. Typical values noted reflect the approximate parameter means at  $T_{\text{A}} = 25\text{ }^\circ\text{C}$  under nominal conditions unless otherwise noted.

Symbol	Characteristic	Min	Typ	Max	Unit	Notes
--------	----------------	-----	-----	-----	------	-------

**PWM Module timing**

$f_{\text{CLOCK}}$	Input PWM clock range on CLOCK	7.68	–	30.72	kHz	
$f_{\text{CLOCK(LOW)}}$	Input PWM clock low frequency detection range on CLOCK	1.0	2.0	4.0	kHz	(32)
$f_{\text{CLOCK(HIGH)}}$	Input PWM clock high frequency detection range on CLOCK	100	–	400	kHz	(32)
$f_{\text{PWM}}$	Output PWM frequency range using external clock on CLOCK	31.25	–	781	Hz	(31)
$A_{\text{FPWM(CAL)}}$	Output PWM frequency accuracy using calibrated oscillator	-10	–	+10	%	(31)
$f_{\text{PWM(0)}}$	Default output PWM frequency using internal oscillator	84	120	156	Hz	
$t_{\text{CSB(MIN)}}$	CSB calibration low minimum time detection range	14	20	26	$\mu\text{s}$	
$t_{\text{CSB(MAX)}}$	CSB calibration low maximum time detection range	140	200	260	$\mu\text{s}$	
$R_{\text{PWM\_1k}}$	Output PWM duty cycle range for $f_{\text{PWM}} = 1.0\text{ kHz}$ for high speed slew rate	10	–	94	%	(32)
$R_{\text{PWM\_400}}$	Output PWM duty cycle range for $f_{\text{PWM}} = 400\text{ Hz}$	6.0	–	98	%	(32)
$R_{\text{PWM\_200}}$	Output PWM duty cycle range for $f_{\text{PWM}} = 200\text{ Hz}$	5.0	–	98	%	(32)

**Input timing**

$t_{\text{IN}}$	Direct input toggle timeout	175	250	325	ms	
-----------------	-----------------------------	-----	-----	-----	----	--

**Autoretry timing**

$t_{\text{AUTO}}$	Autoretry period	105	150	195	ms	
-------------------	------------------	-----	-----	-----	----	--

**Temperature on the GND flag**

$T_{\text{OTWAR}}$	Thermal prewarning detection	110	125	140	$^\circ\text{C}$	(33)
$T_{\text{FEED}}$	Analog temperature feedback at $T_{\text{A}} = 25\text{ }^\circ\text{C}$ with $R_{\text{CSNS}} = 2.5\text{ k}\Omega$	1.15	1.20	1.25	V	
$DT_{\text{FEED}}$	Analog temperature feedback derating with $R_{\text{CSNS}} = 2.5\text{ k}\Omega$	-3.5	-3.7	-3.9	$\text{mV}/^\circ\text{C}$	(34)

**Notes**

31. Clock Fail detector available for PWM\_en bit is set to logic [1] and CLOCK\_sel is set to logic [0].
32. The PWM ratio is measured at  $V_{\text{HS}} = 50\%$  of  $V_{\text{PWR}}$  and for the default SR value. It is possible to put the device fully-on (PWM duty cycle 100%) and fully-off (duty cycle 0%). For values outside this range, a calibration is needed between the PWM duty cycle programming and the PWM on the output with  $R_{\text{L}} = 5.0\text{ }\Omega$  resistive load.
33. Typical value guaranteed per design.
34. Value guaranteed per statistical analysis.

**Table 5. Dynamic electrical characteristics (continued)**

Characteristics noted under conditions  $6.0\text{ V} \leq V_{\text{PWR}} \leq 20\text{ V}$ ,  $3.0\text{ V} \leq V_{\text{DD}} \leq 5.5\text{ V}$ ,  $-40\text{ }^\circ\text{C} \leq T_{\text{A}} \leq 125\text{ }^\circ\text{C}$ ,  $\text{GND} = 0\text{ V}$  unless otherwise noted. Typical values noted reflect the approximate parameter means at  $T_{\text{A}} = 25\text{ }^\circ\text{C}$  under nominal conditions unless otherwise noted.

Symbol	Characteristic	Min	Typ	Max	Unit	Notes
<b>SPI interface characteristics<sup>(35)</sup></b>						
$f_{\text{SPI}}$	Maximum frequency of SPI operation	–	–	8.0	MHz	
$t_{\text{WRSTB}}$	Required low state duration for RSTB	10	–	–	$\mu\text{s}$	(36)
$t_{\text{CSB}}$	Rising edge of CSB to falling edge of CSB (required setup time)	–	–	1.0	$\mu\text{s}$	(37)
$t_{\text{ENBL}}$	Rising edge of RSTB to falling edge of CSB (required Setup time)	–	–	5.0	$\mu\text{s}$	(37)
$t_{\text{LEAD}}$	Falling edge of CSB to Rising Edge of SCLK (required setup time)	–	–	500	ns	(37)
$t_{\text{WSCLKh}}$	Required high state duration of SCLK (required setup time)	–	–	50	ns	(37)
$t_{\text{WSCLKl}}$	Required low state duration of SCLK (required setup time)	–	–	50	ns	(37)
$t_{\text{LAG}}$	Falling edge of SCLK to rising edge of CSB (required setup time)	–	–	60	ns	(37)
$t_{\text{SI(SU)}}$	SI to falling edge of SCLK (required setup time)	–	–	37	ns	(38)
$t_{\text{SI(HOLD)}}$	Falling edge of SCLK to SI (required setup time)	–	–	49	ns	(38)
$t_{\text{RSO}}$	SO rise time • $C_{\text{L}} = 80\text{ pF}$	–	–	13	ns	
$t_{\text{FSO}}$	SO Fall time • $C_{\text{L}} = 80\text{ pF}$	–	–	13	ns	
$t_{\text{RSI}}$	SI, CSB, SCLK, incoming signal rise time	–	–	13	ns	(38)
$t_{\text{FSI}}$	SI, CSB, SCLK, incoming signal fall time	–	–	13	ns	(38)
$t_{\text{SO(EN)}}$	Time from falling edge of CSB to SO low-impedance	–	–	60	ns	(39)
$t_{\text{SO(DIS)}}$	Time from rising edge of CSB to SO high-impedance	–	–	60	ns	(40)

**Notes**

35. Parameters guaranteed by design.
36. RSTB low duration measured with outputs enabled and going to OFF or disabled condition.
37. Maximum setup time required for the 07XS3200 is the minimum guaranteed time needed from the microcontroller.
38. Rise and Fall time of incoming SI, CSB, and SCLK signals suggested for design consideration to prevent the occurrence of double pulsing.
39. Time required for output status data to be available for use at SO. 1.0 k $\Omega$  on pull-up on CSB.
40. Time required for output status data to be terminated at SO. 1.0 k $\Omega$  on pull-up on CSB.



## 4.4 Timing diagrams

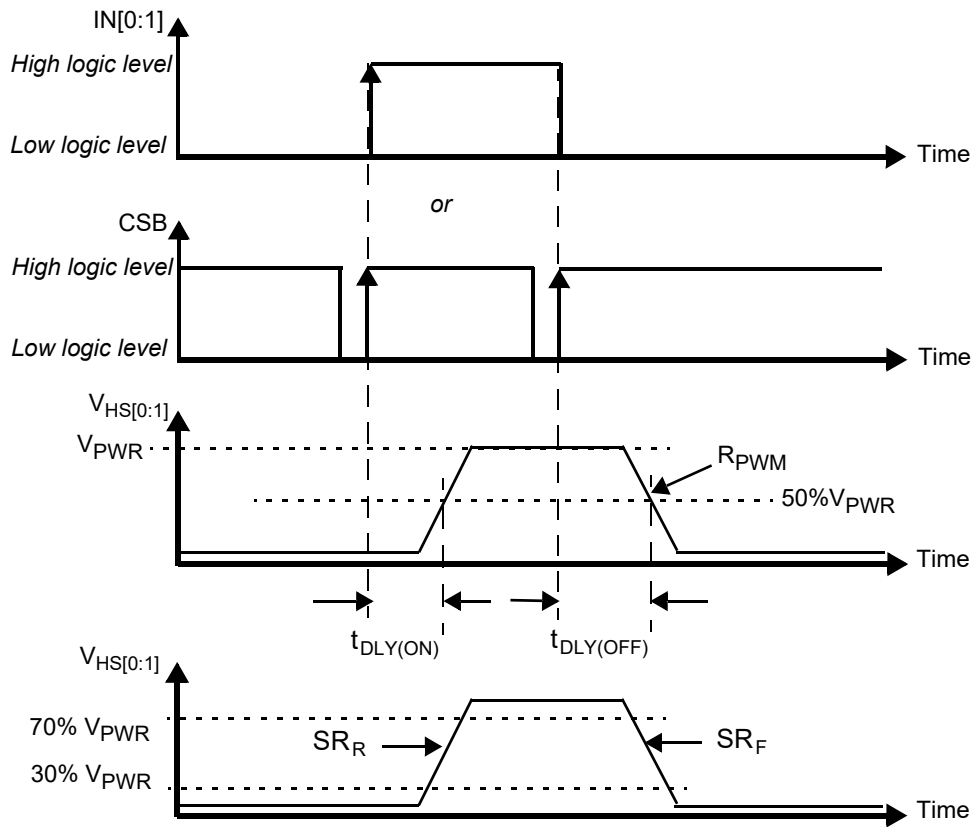

Figure 4. Output slew rate and time delays

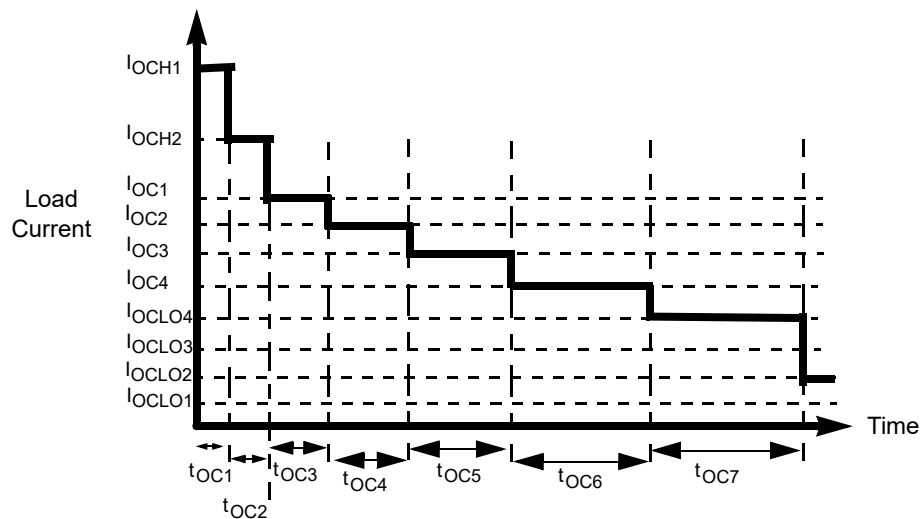

Figure 5. Overcurrent shutdown protection

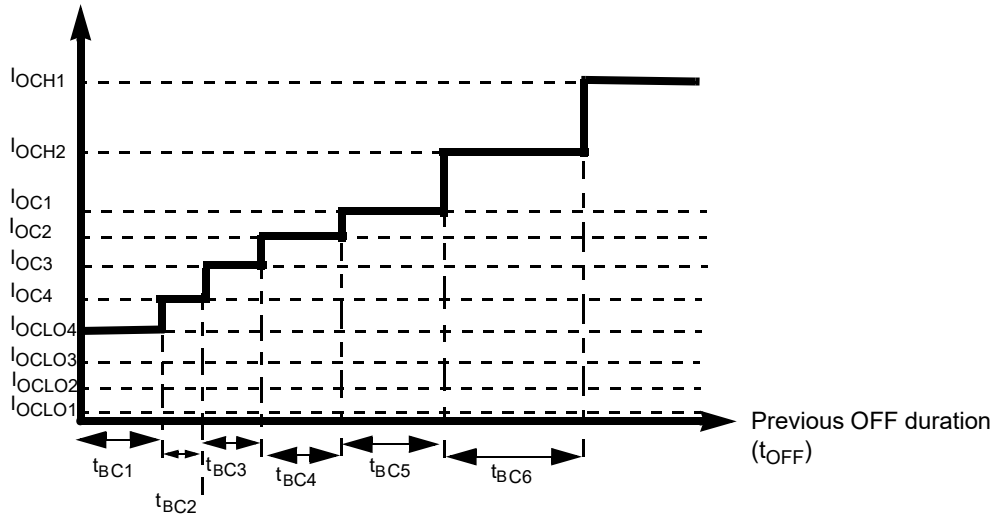

Figure 6. Bulb cooling management

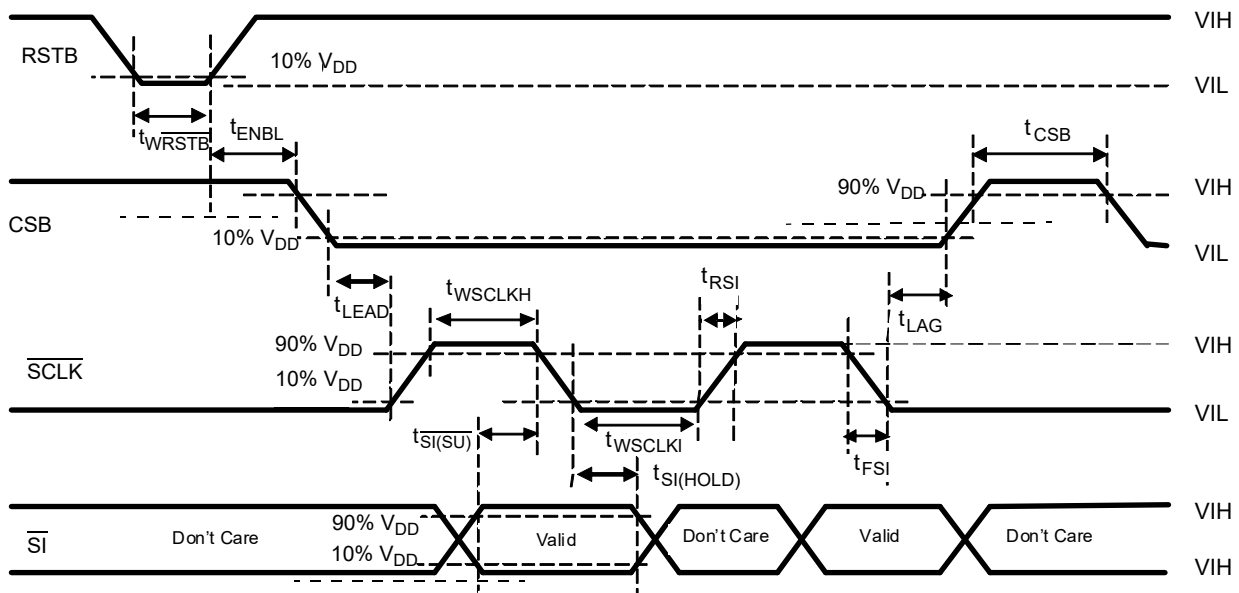

Figure 7. Input timing switching characteristics

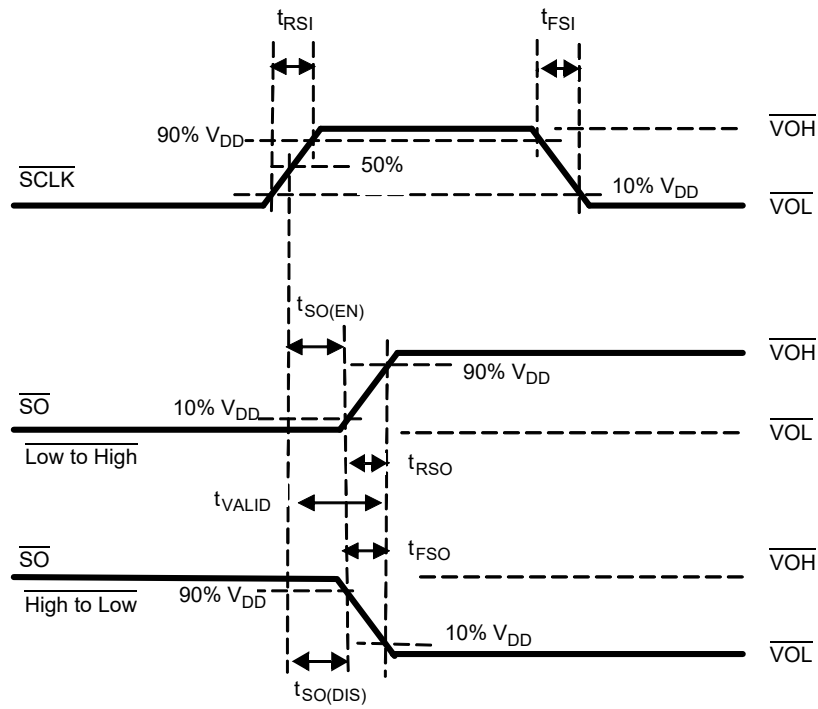

Figure 8. SCLK waveform and valid SO data delay time

# 5 Functional description

## 5.1 Introduction

The 07XS3200 is one in a family of devices designed for low-voltage automotive lighting applications. Its two low  $R_{DS(on)}$  MOSFETs (dual 7.0 m $\Omega$ ) can control two separate 55 W bulbs and/or Xenon modules.

Programming, control and diagnostics are accomplished using a 16-bit SPI interface. Its output with selectable slew rate improves electromagnetic compatibility (EMC) behavior. Additionally, each output has its own parallel input or SPI control for pulse-width modulation (PWM) control if desired. The 07XS3200 allows the user to program via the SPI, the fault current trip levels and duration of acceptable lamp inrush. The device has fail-safe mode to provide fail-safe functionality of the outputs in case of MCU damaged.

## 5.2 Functional pin description

### 5.2.1 Output current monitoring (CSNS)

The Current Sense pin provides a current proportional to the designated HS0:HS1 output or a voltage proportional to the temperature on the GND flag. That current is fed into a ground-referenced resistor (2.5 k $\Omega$  typical) and its voltage is monitored by an MCU's A/D. The output type is selected via the SPI. This pin can be tri-stated through the SPI.

### 5.2.2 Direct inputs (IN0, IN1)

Each IN input wakes the device. The IN0:IN1 high-side input pins are also used to directly control HS0:HS1 high-side output pins. If the outputs are controlled by PWM module, the external PWM clock is applied to IN0 pin. These pins are to be driven with CMOS levels, and they have a passive internal pull-down,  $R_{DWN}$ .

### 5.2.3 Fault status (FSB)

This pin is an open drain configured output requiring an external pull-up resistor to  $V_{DD}$  for fault reporting. If a device fault condition is detected, this pin is active LOW. Specific device diagnostics and faults are reported via the SPI SO pin.

### 5.2.4 Wake (WAKE)

The WAKE input wakes the device. An internal clamp protects this pin from high damaging voltages with a series resistor (10 k $\Omega$  typ). This input has a passive internal pull-down,  $R_{DWN}$ .

### 5.2.5 PWM Clock (CLOCK)

The clock input wakes the device. The PWM frequency and timing are generated from clock input by the PWM module. The clock input frequency is the selectable factor  $2^7 = 128$ . This input has a passive internal pull-down,  $R_{DWN}$ .

### 5.2.6 Reset (RSTB)

The RESET input wakes the device. This is used to initialize the device configuration and fault registers, as well as place the device in a low-current Sleep mode. The pin also starts the watchdog timer when transitioning from logic [0] to logic [1]. This pin has a passive internal pull-down,  $R_{DWN}$ .

## 5.2.7 Chip select (CSB)

The CSB pin enables communication with the master microcontroller (MCU). When this pin is in a logic [0] state, the device is capable of transferring information to, and receiving information from, the MCU. The 07XS3200 latches in data from the Input Shift registers to the addressed registers on the rising edge of CSB. The device transfers status information from the power output to the Shift register on the falling edge of CSB. The SO output driver is enabled when CSB is logic [0]. CSB should transition from a logic [1] to a logic [0] state only when SCLK is a logic [0]. CSB has an active internal pull-up from  $V_{DD}$ ,  $I_{UP}$ .

## 5.2.8 Serial clock (SCLK)

The SCLK pin clocks the internal shift registers of the 07XS3200 device. The serial input (SI) pin accepts data into the input shift register on the falling edge of the SCLK signal while the serial output (SO) pin shifts data information out of the SO line driver on the rising edge of the SCLK signal. It is important the SCLK pin be in a logic low state whenever CSB makes any transition. For this reason, it is recommended the SCLK pin be in a logic [0] whenever the device is not accessed (CSB logic [1] state). SCLK has an active internal pull-down. When CSB is logic [1], signals at the SCLK and SI pins are ignored and SO is tri-stated (high-impedance) (see [Figure 10](#), page 23). SCLK input has an active internal pull-down,  $I_{DOWN}$ .

## 5.2.9 Serial input (SI)

This is a serial interface (SI) command data input pin. Each SI bit is read on the falling edge of SCLK. A 16-bit stream of serial data is required on the SI pin, starting with D15 (MSB) to D0 (LSB). The internal registers of the 07XS3200 are configured and controlled using a 5-bit addressing scheme described in [Table 10](#), page 33. Register addressing and configuration are described in [Tables 11](#), page 33. SI input has an active internal pull-down,  $I_{DOWN}$ .

## 5.2.10 Digital drain voltage (VDD)

This pin is an external voltage input pin used to supply power to the SPI circuit. In the event  $V_{DD}$  is lost ( $V_{DD}$  Failure), the device goes to Fail-safe mode.

## 5.2.11 Ground (GND)

These pins are the ground for the device.

## 5.2.12 Positive power supply (VPWR)

This pin connects to the positive power supply and is the source of operational power for the device. The VPWR contact is the backside surface mount tab of the package.

## 5.2.13 Serial output (SO)

The SO data pin is a tri-stateable output from the shift register. The SO pin remains in a high impedance state until the CSB pin is put into a logic [0] state. The SO data is capable of reporting the status of the output, the device configuration, the state of the key inputs, etc. The SO pin changes state on the rising edge of SCLK and reads out on the falling edge of SCLK. SO reporting descriptions are provided in [Table 23](#), page 39.

## 5.2.14 High-side outputs (HS0, HS1)

Protected 7.0 mΩ high-side power outputs to the load.

## 5.2.15 Fail-safe input (FSI)

This pin incorporates an active internal pull-up current source from internal supply ( $V_{REG}$ ). This enables the watchdog timeout feature. When the FSI pin is opened, the watchdog circuit is enabled. After a watchdog timeout occurs, the output states depends on IN[0:1]. When the FSI pin is connected to GND, the watchdog circuit is disabled. The output states depends on IN[0:1] in case of  $V_{DD}$  failure condition, in case  $V_{DD}$  failure detection is activated ( $V_{DD\_FAIL\_en}$  bit sets to logic [1]).

## 5.3 Functional internal block description

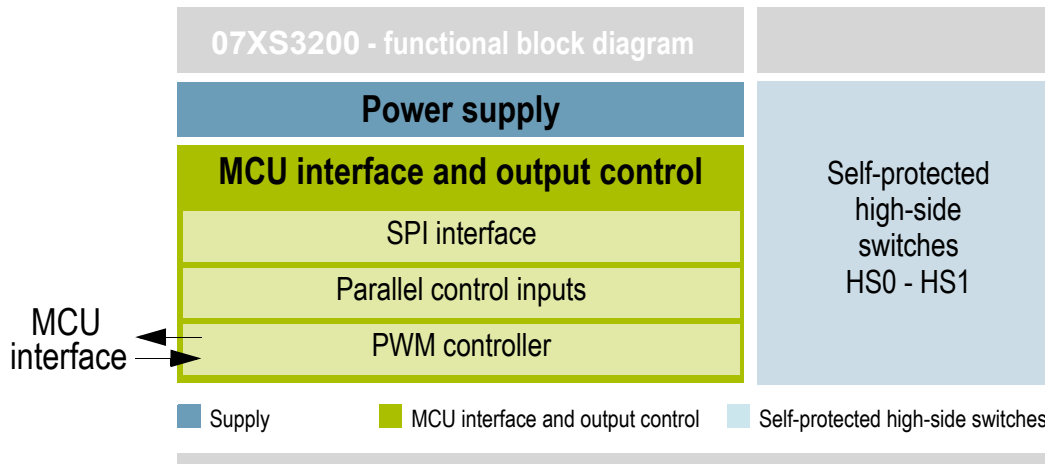

Figure 9. Functional block diagram

### 5.3.1 Power supply

The 07XS3200 is designed to operate from 4.0 V to 28 V on the VPWR pin. Characteristics are provided from 6.0 V to 20 V for the device. The VPWR pin supplies power to internal regulator, analog, and logic circuit blocks. The  $V_{DD}$  supply is used for Serial Peripheral Interface (SPI) communication to configure and diagnose the device. This IC architecture provides a low quiescent current sleep mode. Applying  $V_{PWR}$  and  $V_{DD}$  to the device places the device in the Normal mode. The device transits to Fail-safe mode in case of failures on the SPI or/and on  $V_{DD}$  voltage.

### 5.3.2 High-side switches: HS0–HS1

These pins are the high-side outputs controlling automotive lamps located for the front of vehicle, such as 65 W/55 W bulbs and Xenon-HID modules. N-channel MOSFETs with 7.0 m $\Omega$   $R_{DS(on)}$  are self-protected and present extended diagnostics to detect bulb outage and a short-circuit fault condition. The HS output is actively clamped during turn off of inductive loads and inductive battery line. When driving DC motor or solenoid loads demand multiple switching, an external recirculation device must be used to maintain the device in its Safe Operating Area.

### 5.3.3 MCU interface and output control

In Normal mode, each bulb is controlled directly from the MCU through the SPI. A pulse width modulation control module allows improvement of lamp lifetime with bulb power regulation (PWM frequency range from 100 Hz to 400 Hz) and addressing the dimming application (day running light). An analog feedback output provides a current proportional to the load current or the temperature of the board. The SPI is used to configure and to read the diagnostic status (faults) of high-side outputs. The reported fault conditions are: openload, short-circuit to battery, short-circuit to ground (overcurrent and severe short-circuit), thermal shutdown, and under/overvoltage. The vehicle is lighter thanks to accurate and configurable overcurrent detection circuitry and wire-harness optimization.

In Fail-safe mode, each lamp is controlled with dedicated parallel input pins. The device is configured in default mode.

# 6 Functional device operation

## 6.1 SPI protocol description

The SPI interface has a full duplex, three-wire synchronous data transfer with four I/O lines associated with it: Serial Input (SI), Serial Output (SO), Serial Clock (SCLK), and Chip Select (CSB).

The SI/SO pins of the 07XS3200 follow a first-in first-out (D15 to D0) protocol, with both input and output words transferring the most significant bit (MSB) first. All inputs are compatible with 5.0 V or 3.3 V CMOS logic levels.

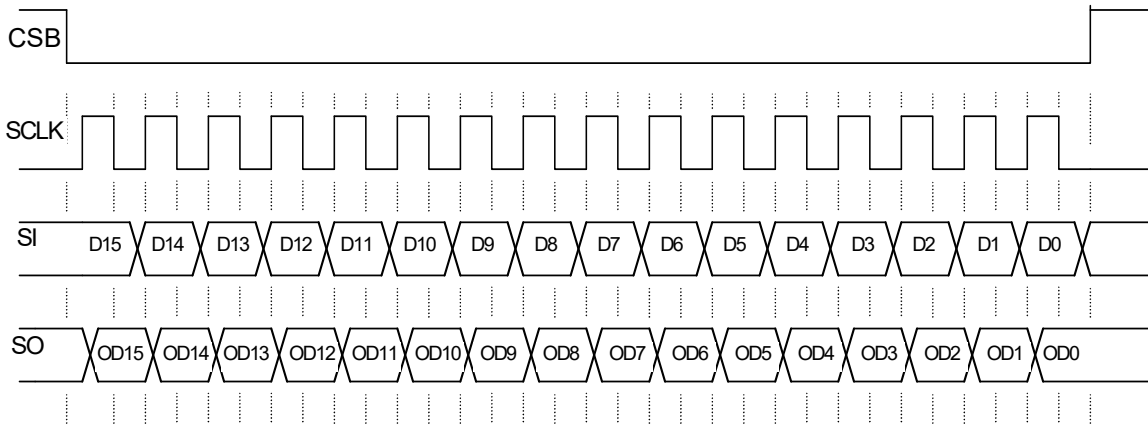

- Notes
1. RSTB is a logic [1] state during the above operation.
  2. D15:D0 relate to the most recent ordered entry of data into the device.
  3. OD15:OD0 relate to the first 16 bits of ordered fault and status data out of the device.

**Figure 10. Single 16-bit word SPI communication**

## 6.2 Operational modes

The 07XS3200 has four operating modes: Sleep, Normal, Fail-safe and Fault. [Table 6](#) and [Figure 12](#) summarize details contained in succeeding paragraphs.

The [Figure 11](#) describes an internal signal called IN\_ON[x] depending on IN[x] input.

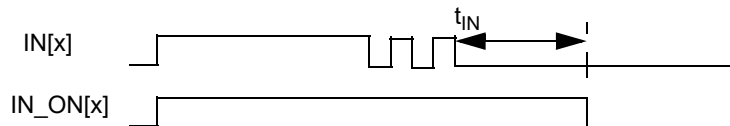

**Figure 11. IN\_ON[x] internal signal**

The 07XS3200 transits to operating modes according to the following signals:

- wake-up = RSTB or WAKE or IN\_ON[0] or IN\_ON[1] or CLOCK\_ON,
- fail = ( $V_{DD}$  Failure and VDD\_FAIL\_en) or (Watchdog timeout and FSI input not shorted to ground),
- fault = OC[0:1] or OT[0:1] or SC[0:1] or UV or (OV and  $\overline{OV}_{dis}$ ).

**Table 6. 07XS3200 operating modes**

Mode	Wake-up	Fail	Fault	Comments
Sleep	0	x	x	Device is in Sleep mode. All outputs are OFF.
Normal	1	0	0	Device is currently in Normal mode. Watchdog is active if enabled.
Fail-safe	1	1	0	Device is currently in Fail-safe mode due to watchdog timeout or $V_{DD}$ Failure conditions. The output states are defined with the RFS resistor connected to FSI.
Fault	1	X	1	Device is currently in fault mode. The faulted output(s) is (are) OFF. The safe autoretry circuitry is active to turn-on again the output(s).

x = Don't care.

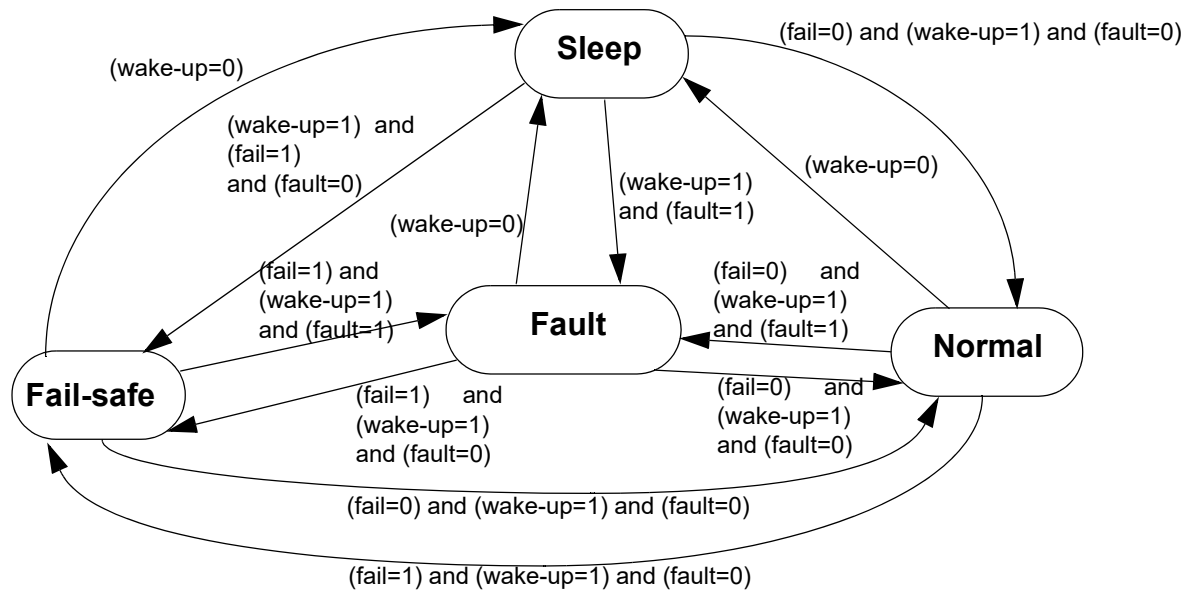

**Figure 12. Operating modes**

## 6.2.1 Sleep mode

The 07XS3200 is in Sleep mode when:

- $V_{PWR}$  and  $V_{DD}$  are within the normal voltage range,
- wake-up = 0,
- fail = X,
- fault = X.

This is the Default mode of the device after first applying battery voltage ( $V_{PWR}$ ) prior to any I/O transitions. This is also the state of the device when the WAKE and RSTB, CLOCK\_ON and IN\_ON[0:1] are logic [0]. In the Sleep mode, the output and all unused internal circuitry, such as the internal regulator, are off to minimize draw current. In addition, all SPI-configurable features of the device are as set to logic [0].

In the event of an external  $V_{PWR}$  supply disconnect, an unexpected current consumption may sink on the VDD supply pin (In Sleep state). This current leakage is about 70 mA instead of 5.0  $\mu$ A and it may impact the device reliability. The device recovers its normal operational mode once  $V_{PWR}$  is reconnected.

To avoid this unexpected current leakage on the VDD supply pin, maintain the device in Normal mode with RSTB pin set to logic[1]. This allows diagnosis of the battery disconnection event through UV fault reporting in SPI. Then, apply 0 V on the VDD supply pin to switch the device to Sleep state.



## 6.2.2 Normal mode

The 07XS3200 is in Normal mode when:

- $V_{PWR}$  and  $V_{DD}$  are within the normal voltage range,
- wake-up = 1,
- fail = 0,
- fault = 0.

In this mode, the NM bit is set to  $\overline{\text{Ifault\_contrologic}}$  [1] and the outputs HS[0:1] are under control, as defined by the hson signal:

$\text{hson}[x] = (((\text{IN}[x] \text{ and } \overline{\text{DIR\_dis}}[x]) \text{ or } \text{On bit}[x]) \text{ and } \overline{\text{PWM\_en}}) \text{ or } (\text{On bit}[x] \text{ and } \text{Duty\_cycle}[x] \text{ and } \overline{\text{PWM\_en}})$ .

In this mode and also in Fail-safe, the fault condition reset depends on fault\_control signal, as defined below:

$\text{fault\_control}[x] = ((\text{IN\_ON}[x] \text{ and } \overline{\text{DIR\_dis}}[x]) \text{ and } \overline{\text{PWM\_en}}) \text{ or } (\text{On bit}[x])$ .

### 6.2.2.1 Programmable PWM module

The outputs HS[0:1] are controlled by the programmable PWM module if PWM\_en and On bits are set to logic [1].

The clock frequency from CLOCK input pin or from the internal clock is the factor  $2^7$  (128) of the output PWM frequency (CLOCK\_sel bit).

The outputs HS[0:1] can be controlled in the range of 5.0% to 98% with a resolution of 7 bits of duty cycle (Table 7). The state of other IN pin is ignored.

**Table 7. Output PWM resolution**

On bit	Duty cycle	Output state
0	X	OFF
1	0000000	PWM (1/128 duty cycle)
1	0000001	PWM (2/128 duty cycle)
1	0000010	PWM (3/128 duty cycle)
1	n	PWM ((n+1)/128 duty cycle)
1	1111111	fully ON

The timing includes seven programmable PWM switching delay (number of PWM clock rising edges) to improve overall EMC behavior of the light module (Table 8).

**Table 8. Output PWM switching delay**

Delay bits	Output delay
000	no delay
001	16 PWM clock periods
010	32 PWM clock periods
011	48 PWM clock periods
100	64 PWM clock periods
101	80 PWM clock periods
110	96 PWM clock periods
111	112 PWM clock periods

The clock frequency from CLOCK is permanently monitored in order to report a clock failure in case the frequency is out a specified frequency range (from  $f_{\text{CLOCK(LOW)}}$  to  $f_{\text{CLOCK(HIGH)}}$ ). In case of clock failure, no PWM feature is provided, the On bit defines the outputs state and the CLOCK\_fail bit reports [1].

## 6.2.2.2 Calibratable internal clock

The internal clock can vary as much as  $\pm 30$  percent corresponding to typical  $f_{PWM(0)}$  output switching period.

Using the existing SPI inputs and the precision timing reference already available to the MCU, the 07XS3200 allows clock period setting within  $\pm 10$  percent of accuracy. Calibrating the internal clock is initiated by defined word to CALR register. The calibration pulse is provided by the MCU. The pulse is sent on the CSB pin after the SPI word is launched. At the moment, the CSB pin transitions from logic [1] to [0] until from logic [0] to [1] determines the period of internal clock with a multiplicative factor of 128.

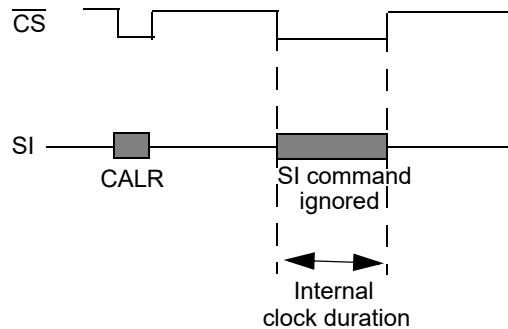

**Figure 13. Internal clock calibration diagram**

In case a negative CSB pulse is outside a predefined time range (from  $t_{CSB(MIN)}$  to  $t_{CSB(MAX)}$ ), the calibration event is ignored and the internal clock is unaltered or reset to the default value ( $f_{PWM(0)}$ ), if this was not calibrated before.

The calibratable clock is used, instead of the clock from CLOCK input, when CLOCK\_sel is set to [1].

## 6.2.3 Fail-safe mode

The 07XS3200 is in Fail-safe mode when:

- $V_{PWR}$  is within the normal voltage range,
- wake-up = 1,
- fail = 1,
- fault = 0.

### 6.2.3.1 Watchdog

If the FSI input is not grounded, the watchdog timeout detection is active when either the WAKE or IN\_ON[0:1] or RSTB input pin transitions from logic [0] to logic [1]. The WAKE input is capable of being pulled up to  $V_{PWR}$  with a series of limiting resistance limiting the internal clamp current according to the specification.

The watchdog timeout is a multiple of an internal oscillator. As long as the WD bit (D15) of an incoming SPI message is toggled within the minimum watchdog timeout period (WDTO), the device operates normally.

### 6.2.3.2 Fail-safe conditions

If an internal watchdog timeout occurs before the WD bit for FSI open (Table 9) or in case of  $V_{DD}$  failure condition ( $V_{DD} < V_{DD(FAIL)}$ ) for VDD\_FAIL\_en bit is set to logic [1], the device reverts to a Fail-safe mode until the WD bit is written to logic [1] (see Fail-safe to Normal mode transition paragraph) and  $V_{DD}$  is within the normal voltage range.

**Table 9. SPI watchdog activation**

Typical RFSI ( $\Omega$ )	Watchdog
0 (shorted to ground)	Disabled
(open)	Enabled

During the Fail-safe mode, the outputs depend on the corresponding input. The SPI register content is reset to their default value (except POR bit) and fault protections are fully operational.

The Fail-safe mode can be detected by monitoring the NM bit is set to [0].

## 6.2.4 Normal and fail-safe mode transitions

### 6.2.4.1 Transition Fail-safe to Normal mode

To leave the Fail-safe mode,  $V_{DD}$  must be in nominal voltage and the microcontroller has to send a SPI command with WDIN bit set to logic [1]; the other bits are not considered. The previous latched faults are reset by the transition into Normal mode (autoretry included). Moreover, the device can be brought out of the Fail-safe mode due to watchdog timeout issue by forcing the FSI pin to logic [0].

### 6.2.4.2 Transition Normal to Fail-safe mode

To leave the Normal mode, a fail-safe condition must occurred (fail=1). The previous latched faults are reset by the transition into Fail-safe mode (autoretry included).

## 6.2.5 Fault mode

The 07XS3200 is in Fault mode when:

- $V_{PWR}$  and  $V_{DD}$  are within the normal voltage range,
- wake-up = 1,
- fail = X,
- fault=1.

This device indicates the faults below as they occur by driving the FSB pin to logic [0] for RSTB input is pulled up:

- Overtemperature fault,
- Overcurrent fault,
- Severe short-circuit fault,
- Output(s) shorted to  $V_{PWR}$  fault in OFF state,
- Openload fault in OFF state,
- Overvoltage fault (enabled by default),
- Undervoltage fault.

The FSB pin automatically returns to logic [1] when the fault condition is removed, except for overcurrent, severe short-circuit, overtemperature and undervoltage which is reset by a new turn-on command (each fault\_control signal to be toggled).

Fault information is retained in the SPI fault register and is available (and reset) via the SO pin during the first valid SPI communication. The openload fault in ON state is only reported through SPI register without effect on the corresponding output state (HS[x]) and the  $\overline{FS}$  pin.

## 6.2.6 Start-up sequence

The 07XS3200 enters in Normal mode after start-up if following sequence is provided:

- $V_{PWR}$  and  $V_{DD}$  power supplies must be above their undervoltage thresholds
- generate wake-up event (wake-up=1) from 0 to 1 on RSTB. The device switches to normal mode with SPI register content is reset (as defined in [Table 11](#) and [Table 23](#)). All features of the 07XS3200 are available after 50  $\mu$ s typical, and all SPI registers are set to default values (set to logic [0]).
- toggle WD bit from 0 to 1

And, in case the PWM module is used (PWM\_en bit is set to logic [1]) with an external reference clock:

- apply PWM clock on CLOCK input pin after maximum 200  $\mu$ s (min. 50  $\mu$ s)

If the correct start-up sequence is not provided, the PWM function is not guaranteed.

## 6.3 Protection and diagnostic features

### 6.3.1 Protections

#### 6.3.1.1 Overtemperature fault

The 07XS3200 incorporates over-temperature detection and shutdown circuitry for each output structure.

Two cases need to be considered when the output temperature is higher than  $T_{SD}$ :

- If the output command is ON: the corresponding output is latched OFF. FSB is latched to logic [0]. To delatch the fault and be able to turn ON again the outputs, the failure condition must disappear and the autoretry circuitry must be active, or the corresponding output must be commanded OFF and then ON (toggling `fault_control` signal of corresponding output) or the  $V_{SUPPLY(POR)}$  condition, if  $V_{DD} = 0$ .
- If the output command is OFF: FSB changes to logic [0] till the corresponding output temperature are below  $T_{SD}$ .

For both cases, the fault register OT[0:1] bit into the status register is set to [1]. The fault bits are cleared in the status register after a SPI read command.

#### 6.3.1.2 Overcurrent fault

The 07XS3200 incorporates output shutdown in order to protect each output structure against resistive short-circuit condition. This protection is composed by four predefined current levels (time dependent) to fit Xenon-HID manners by default or 55 W bulb profiles, selectable by Xenon bit (as illustrated [Figure 17](#), page 36).

In the first turn-on, the lamp filament is cold and the current is huge. `Fault_control` signal transitions from logic [0] to [1] or an autoretry defines this event. In this case, the overcurrent protection is fitted to inrush current, as shown in [Figure 5](#). This overcurrent protection is programmable: OC[1:0] bits select overcurrent slope speed and OCHI1 current step can be removed in case the OCHI bit is set to [1].

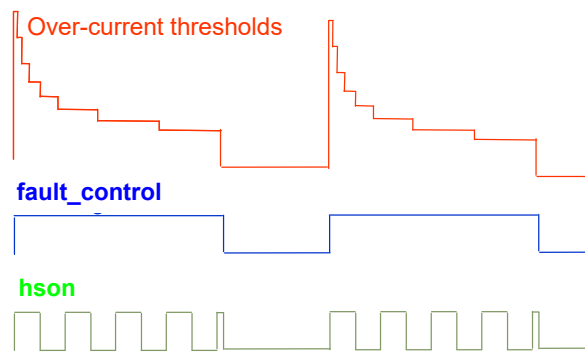

**Figure 14. Overcurrent detection profile**

In Steady state, the wire harness is protected by OCLO2 current level by default. Three other DC overcurrent levels are available: OCLO1 or OCLO3 or OCLO4 based on the state of the OCLO[1,0] bits.

If the load current level ever reaches the overcurrent detection level, the corresponding output latches the output OFF and FSB is also latched to logic [0]. To delatch the fault and be able to turn ON again the corresponding output, the failure condition must disappear and the autoretry circuitry must be active or the corresponding output must be commanded OFF and then ON (toggling `fault_control` signal of corresponding output) or  $V_{SUPPLY(POR)}$  condition if  $V_{DD} = 0$ .

The SPI fault report (OC[0:1] bits) is removed after a read operation.

In Normal mode using internal PWM module, the 07XS3200 incorporates also a cooling bulb filament management if OC\_mode and Xenon are set to logic [1]. In this case, the first step of multi-step overcurrent protection depends on the previous OFF duration, as illustrated in [Figure 6](#). The following figure illustrates the current level used in function to the duration of previous OFF state (toff). The slope of cooling bulb emulator is configurable with OCOFFCB[1:0] bits.

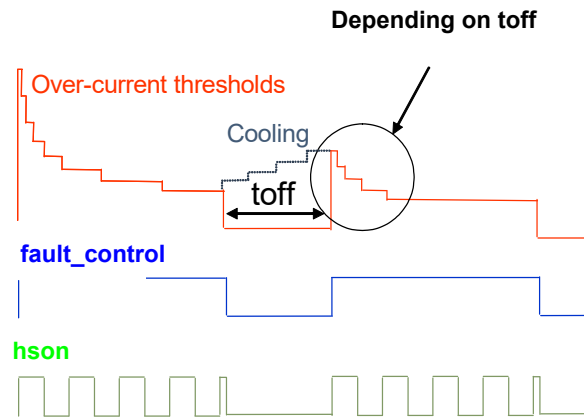

**Figure 15. Bulb cooling principle**

### 6.3.1.3 Severe short-circuit fault

The 07XS3200 provides output shutdown to protect each output in case of a severe short-circuit during of the output switching.

If the short-circuit impedance is below  $R_{SHORT}$ , the device latches the output OFF, FSB changes to logic [0] and the fault register SC[0:1] bit is set to [1]. To delatch the fault and be able to turn ON again the outputs, the failure condition must disappear and the corresponding output must be commanded OFF and then ON (toggling fault\_control signal of corresponding output) or  $V_{SUPPLY(POR)}$  condition if  $V_{DD} = 0$ . The SPI fault report (SC[0:1] bits) is removed after a read operation.

### 6.3.1.4 Overvoltage fault (enabled by default)

By default, the overvoltage protection is enabled. The 07XS3200 shuts down all outputs and FSB goes to logic [0] during an overvoltage fault condition on the VPWR pin ( $V_{PWR} \geq V_{PWR(OV)}$ ). The outputs remain in the OFF state until the overvoltage condition is removed ( $V_{PWR} \leq V_{PWR(OV)} - V_{PWR(OVHYS)}$ ). When experiencing this fault, the OVF fault bit is set to logic [1] and cleared after either a valid SPI read.

The overvoltage protection can be disabled through the SPI (OV\_dis bit is disabled set to logic [1]). The fault register reflects any overvoltage condition ( $V_{PWR} \geq V_{PWR(OV)}$ ). This overvoltage diagnosis, as a warning, is removed after a read operation, if the fault condition disappears. The HS[0:1] outputs are not commanded in  $R_{DS(on)}$  above the OV threshold.

### 6.3.1.5 Undervoltage fault

The output(s) latch off at some battery voltage below  $V_{PWR(UV)}$ . As long as the  $V_{DD}$  level stays within its operating limits, internal logic reporting and configuration remain accessible. However, it is not possible to turn the output ON again as long as  $V_{PWR}$  remains below  $V_{PWR(UV)}$ . In the case where battery voltage drops below the undervoltage threshold ( $V_{PWR} \leq V_{PWR(UV)}$ ), the outputs turn off, FSB goes to logic [0], and the fault register UV bit is set to [1].

Two cases need to be considered when the battery level recovers ( $V_{PWR} > V_{PWR(UV)_UP}$ ):

- If outputs command are low, FSB goes to logic [1] but the UV bit remains set to 1 until the next read operation (warning report).
- If the output command is ON, FSB remains at logic [0]. To delatch the fault and be able to turn ON again the outputs, the failure condition must disappear and the autoretry circuitry must be active or the corresponding output must be commanded OFF and then ON (toggling fault\_control signal of corresponding output) or  $V_{SUPPLY(POR)}$  condition if  $V_{DD} = 0$ .

In **extended mode**, the output is protected by overtemperature shutdown circuitry. All previous latched faults, occurred when  $V_{PWR}$  was within the normal voltage range, are guaranteed if  $V_{DD}$  is within the operational voltage range or until  $V_{SUPPLY(POR)}$  if  $V_{DD} = 0$ . Any new OT fault is detected (VDD failure included) and reported through SPI above  $V_{PWR(UV)}$ . The output state is not changed as long as the  $V_{PWR}$  voltage does not drop any lower than 3.5 V typical.

All latched faults (overtemperature, overcurrent, severe short-circuit, over and undervoltage) are reset if:

- $V_{DD} \leq V_{DD(FAIL)}$  with  $V_{PWR}$  in nominal voltage range
- $V_{DD}$  and  $V_{PWR}$  supplies is below  $V_{SUPPLY(POR)}$  voltage value

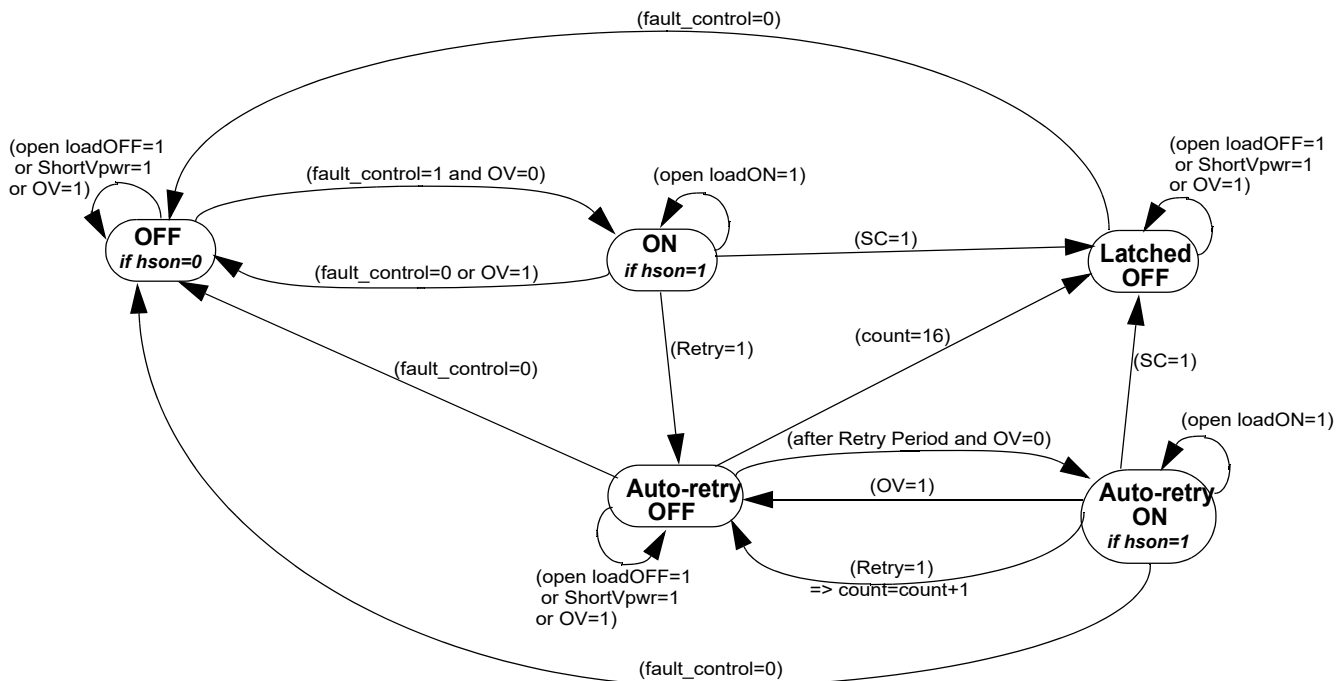

Figure 16. Autoretry state machine

## 6.3.2 Autoretry

The autoretry circuitry is used to reactivate the output(s) automatically in case of overcurrent or overtemperature or undervoltage failure conditions to provide a high availability of the load. Autoretry feature is available in Fault mode. It is activated in case of internal retry signal is set to logic [1]:

$retry[x] = OC[x] \text{ or } OT[x] \text{ or } UV$

The feature retries to switch-on the output(s) after one autoretry period ( $t_{AUTO}$ ) with a limitation in term of number of occurrence (16 for each output). The counter of retry occurrences is reset in case of Fail-safe to Normal or Normal to Fail-safe mode transitions. At each autoretry, the overcurrent detection is set to default values in order to sustain the inrush current. The Figure 16 describes the autoretry state machine.

## 6.3.3 Diagnostic

### 6.3.3.1 Output Shorted to $V_{PWR}$ fault

The 07XS3200 incorporates output shorted to  $V_{PWR}$  detection circuitry in OFF state. Output shorted to  $V_{PWR}$  fault is detected if output voltage is higher than  $V_{OSD(THRES)}$  and reported as a fault condition when the output is disabled (OFF). The output shorted to  $V_{PWR}$  fault is latched into the status register after the internal gate voltage is pulled low enough to turn OFF the output. The  $OS[0:1]$  and  $OL\_OFF[0:1]$  fault bits are set in the status register and FSB pin reports in real time the fault. If the output shorted to  $V_{PWR}$  fault is removed, the status register is cleared after reading the register. The open output shorted to  $V_{PWR}$  protection can be disabled through SPI ( $OS\_DIS[0:1]$  bit).

### 6.3.3.2 Openload faults

The 07XS3200 incorporates three dedicated openload detection circuitries on the output to detect in OFF and in ON state.

### 6.3.3.3 Openload detection in OFF state

The OFF output openload fault is detected when the output voltage is higher than  $V_{OLD(THRES)}$  pulled up with internal current source ( $I_{OLD(OFF)}$ ) and reported as a fault condition when the output is disabled (OFF). The OFF Output openload fault is latched into the status register or when the internal gate voltage is pulled low enough to turn OFF the output. The  $OL\_OFF[0:1]$  fault bit is set in the status register. If the openload fault is removed (FSB output pin goes to high), the status register is cleared after reading the register.

The OFF output openload protection can be disabled through SPI ( $Oloff\_DIS[0:1]$  bit).

### 6.3.3.4 Openload detection in ON state

The ON output openload current thresholds can be chosen by the SPI to detect a standard bulbs or LEDs ( $OLLED[0:1]$  bit set to logic [1]). In the case where load current drops below the defined current threshold  $OLON$  bit is set to logic [1], the output stays ON and FSB is not disturbed.

### 6.3.3.5 Openload detection in ON state for LED

Openload for LEDs only ( $OLLED[0:1]$  set to logic [1]) is detected periodically each  $t_{OLLED}$  (fully-on,  $D[7:0]=FF$ ). To detect  $OLLED$  in fully-on state, the output must be ON at least  $t_{OLLED}$  and PWM module must be enabled ( $PWM\_en = 1$  in GCR register). To delatch the diagnosis, the condition should be removed and the SPI read operation is needed ( $OL\_ON[0:1]$  bit). The ON output openload protection can be disabled through the SPI ( $OLON\_DIS[0:1]$  bit).

## 6.3.4 Analog current recopy and temperature feedback

The CSNS pin is an analog output reporting a current proportional to the designed output current or a voltage proportional to the temperature of the GND flag (pin #14). The routing is SPI programmable ( $TEMP\_en$ ,  $CSNS\_en$ ,  $CSNS\_s[1,0]$  and  $CSNS\_ratio\_s$  bits). If the current recopy is active, the CSNS output delivers current only during ON time of the output switch without overshoot. The maximum current is 2.0 mA, typical. The typical value of external CSNS resistor connected to the ground is 2.5 k $\Omega$ . The current recopy is not active in Fail-safe mode.

### 6.3.4.1 Temperature prewarning detection

In Normal mode, the 07XS3200 provides a temperature prewarning reported via the SPI, in case the temperature of the GND flag is higher than  $T_{OTWAR}$ . This diagnosis ( $OTW$  bit set to [1]) is latched in the SPI  $DIAGR0$  register. To delatch, a read SPI command is needed.

### 6.3.5 Active clamp on VPWR

The device provides an active gate clamp circuit in order to limit the maximum transient  $V_{PWR}$  voltage at  $V_{PWR(CLAMP)}$ . In case of an overload on an output, the corresponding output is turned off, which leads to high voltage at  $VPWR$  with an inductive  $V_{PWR}$  line. When the  $V_{PWR}$  voltage exceeds  $V_{PWR(CLAMP)}$  threshold, the turn-off on the corresponding output is deactivated and all  $HS[0:1]$  outputs are switched ON automatically to demagnetize the inductive battery line.

### 6.3.6 Reverse battery on VPWR

The output survives the application of reverse voltage as low as -18 V. Under these conditions, the ON resistance of the output is two times higher than a typical ohmic value in forward mode. No additional passive components are required except on the  $V_{DD}$  current path.

### 6.3.7 Ground disconnect protection

In the event the 07XS3200 ground is disconnected from load ground, the device protects itself and safely turns OFF the output, regardless of the state of the output at the time of disconnection (maximum  $V_{PWR} = 16$  V). A 10 k $\Omega$  resistor needs to be added between the MCU and each digital input pin to ensure the device turns off, during a ground disconnect and to prevent this pin from exceeding maximum ratings.

## 6.3.8 Loss of supply lines

### 6.3.8.1 Loss of $V_{DD}$

If the external  $V_{DD}$  supply is disconnected (or not within specification:  $V_{DD} < V_{DD(FAIL)}$ , with the  $VDD\_FAIL\_en$  bit set to logic [1]), all SPI register content is reset.

The outputs can still be driven by the direct inputs IN[0:1] if  $V_{PWR}$  is within specified voltage range. The 07XS3200 uses the battery input to power the output MOSFET-related current sense circuitry and any other internal logic providing Fail-safe device operation with no  $V_{DD}$  supplied. In this state, the overtemperature, overcurrent, severe short-circuit, short to  $V_{PWR}$  and OFF openload circuitry are fully operational, with default values corresponding to all SPI bits are set to logic [0]. No current is conducted from  $V_{PWR}$  to  $V_{DD}$ .

### 6.3.8.2 Loss of $V_{PWR}$

If the external  $V_{PWR}$  supply is disconnected (or not within specification), the SPI configuration, reporting, and daisy chain features are provided for RSTB to set to logic [1] under  $V_{DD}$  in nominal conditions. This fault condition can be diagnosed with UV fault in SPI STATR\_s registers. The SPI pull-up and pull-down current sources are not operational. The previous device configuration is maintained. No current is conducted from  $V_{DD}$  to  $V_{PWR}$ .

### 6.3.8.3 Loss of $V_{PWR}$ and $V_{DD}$

If the external  $V_{PWR}$  and  $V_{DD}$  supplies are disconnected (or not within specification: ( $V_{DD}$  and  $V_{PWR}$ )  $< V_{SUPPLY(POR)}$ ), all SPI register contents are reset, with default values corresponding to all SPI bits set to logic [0] and all latched faults reset.

## 6.3.9 EMC performances

All following tests are performed on the NXP evaluation board in accordance with the typical application schematic.

The device is protected in the event of positive and negative transients on the  $V_{PWR}$  line (per ISO 7637-2).

The 07XS3200 successfully meets the Class 5 of the CISPR25 emission standard and 200 V/m or BCI 200 mA injection level for immunity tests.

## 6.4 Logic commands and registers

### 6.4.1 Serial input communication

SPI communication is accomplished using 16-bit messages. A message is transmitted by the MCU starting with the MSB D15 and ending with the LSB, D0 (Table 10). Each incoming command message on the SI pin can be interpreted using the following bit assignments: the MSB, D15, is the watchdog bit (WDIN). In some cases, output selection is done with bit D13. The next four bits, D14-D12:D10, are used to select the command register. The remaining nine bits, D8:D0, are used to configure and control the outputs and their protection features.

Multiple messages can be transmitted in succession to accommodate those applications where daisy-chaining is desirable, or to confirm transmitted data, as long as the messages are all multiples of 16 bits. Any attempt made to latch in a message that is not 16 bits will be ignored. The 07XS3200 has defined registers, which are used to configure the device and to control the state of the outputs. Table 11 summarizes the SI registers.



**Table 10. SI message bit assignment**

Bit sig	SI Msg bit	Message bit description
MSB	D15	Watchdog in: toggled to satisfy watchdog requirements.
	D13	Register address bit used in some cases for output selection (Table 12).
	D14, D12:D10	Register address bits.
	D9	Not used (set to logic [0]).
LSB	D8:D0	Used to configure the inputs, outputs, and the device protection features and SO status content.

**Table 11. Serial input address and configuration bit map**

SI Register	SI Data															
	D15	D14	D13	D12	D11	D10	D9	D8	D7	D6	D5	D4	D3	D2	D1	D0
STATR_s	WDI_N	X	X	0	0	0	0	0	0	0	0	SOA4	SOA3	SOA2	SOA1	SOA0
PWMR_s	WDI_N	1	A	0	0	1	0	0 <sup>(41)</sup>	ON_s	PWM6_s	PWM5_s	PWM4_s	PWM3_s	PWM2_s	PWM1_s	PWM0_s
CONFR0_s	WDI_N	1	A	0	1	0	0	0	0	0	DIR_dis_s	SR1_s	SR0_s	DELAY2_s	DELAY1_s	DELAY0_s
CONFR1_s	WDI_N	1	A	0	1	1	0	0	0	Retry_unlimited_s	Retry_dis_s	OS_dis_s	OLON_dis_s	OLOFF_dis_s	OLLED_en_s	CSNS_ratio_s
OCR_s	WDI_N	1	A	1	0	0	0	Xenon_s	BC1_s	BC0_s	OC1_s	OC0_s	OCHI_s	OLCO1_s	OLCO0_s	OC_mode_s
GCR	WDI_N	0	0	1	0	1	0	VDD_FAIL_en	PWM_en	CLOCK_sel	TEMP_en	CSNS_en	CSNS1	CSNS0	X	OV_dis
CALR	WDI_N	0	0	1	1	1	0	1	0	1	0	1	1	0	1	1
Register state after RST=0 or VDD(FAIL) or V <sub>SUPPLY</sub> (POR) condition	0	0	0	X	X	X	0	0	0	0	0	0	0	0	0	0

x=Don't care.

s=Output selection with the bit A as defined in Table 12.

**Notes**

41. The PWMR\_s D8 bit must always be a logic low and never placed in a logic high.

## 6.4.2 Device register addressing

The following section describes the possible register addresses (D[14:10]) and their impact on device operation.

### 6.4.2.1 Address XX000—Status register (STATR\_S)

The STATR register is used to read the device status and the various configuration register contents without disrupting the device operation or the register contents. The register bits D[4:0] determine the content of the first sixteen bits of SO data. In addition to the device status, this feature provides the ability to read the content of the PWMR\_s, CONFR0\_s, CONFR1\_s, OCR\_s, GCR and CALR registers (Refer to [Serial output communication \(device status return data\)](#)).

### 6.4.2.2 Address A<sub>1</sub>A<sub>0</sub>001—Output PWM control register (PWMR\_S)

The PWMR\_s register allows the MCU to control the state of corresponding output through the SPI. Each output “s” is independently selected for configuration based on the state of the D13 bit ([Table 12](#)).

**Table 12. Output selection**

A (D13)	HS selection
0	HS0 (default)
1	HS1

Bit D7 sets the output state. A logic [1] enables the corresponding output switch and a logic [0] turns it OFF (if IN input is also pulled down). Bits D6:D0 set the output PWM duty cycle to one of 128 levels for PWM\_en is set to logic [1], as shown [Table 7](#).

### 6.4.2.3 Address A<sub>1</sub>A<sub>0</sub>010—Output configuration register (CONFR0\_S)

The CONFR0\_s register allows the MCU to configure corresponding output switching through the SPI. Each output “s” is independently selected for configuration based on the state of the D14:D13 bits ([Table 12](#)).

For the selected output, a logic [0] on bit D5 (DIR\_DIS\_s) enables the output for direct control. A logic [1] on bit D5 disables the output from direct control (in this case, the output is only controlled by the On bit).

D4:D3 bits (SR1\_s and SR0\_s) are used to select the high or medium or low speed slew rate for the selected output, the default value [00] corresponds to the medium speed slew rate ([Table 13](#)).

**Table 13. Slew rate speed selection**

SR1_s (D4)	SR0_s (D3)	Slew rate speed
0	0	medium (default)
0	1	low
1	0	high
1	1	Not used

Incoming message bits D2:D0 reflect the desired output that will be delayed of predefined PWM clock rising edges number, as shown [Table 8](#), (only available for PWM\_en bit is set to logic [1]).

### 6.4.2.4 Address A<sub>1</sub>A<sub>0</sub>011—Output configuration register (CONFR1\_S)

The CONFR1\_s register allows the MCU to configure corresponding output fault management through the SPI. Each output “s” is independently selected for configuration based on the state of the D14:D13 bits ([Table 12](#)).

A logic [1] on bit D6 (RETRY\_unlimited\_s) disables the autoretry counter for the selected output, the default value [0] corresponds to enable autoretry feature with time limitation.

A logic [1] on bit D5 (RETRY\_dis\_s) disables the autoretry for the selected output, the default value [0] corresponds to enable this feature.

A logic [1] on bit D4 (OS\_dis\_s) disables the output hard shorted to V<sub>PWR</sub> protection for the selected output, the default value [0] corresponds to enable this feature.

A logic [1] on bit D3 (OLON\_dis\_s) disables the ON output openload detection for the selected output, the default value [0] corresponds to enable this feature ([Table 14](#)).

A logic [1] on bit D2 (OLOFF\_dis\_s) disables the OFF output openload detection for the selected output, the default value [0] corresponds to enable this feature.

A logic [1] on bit D1 (OLLED\_en\_s) enables the ON output openload detection for LEDs for the selected output, the default value [0] corresponds to ON output openload detection is set for bulbs (Table 14).

**Table 14. ON openload selection**

OLON_dis_s (D3)	OLLED_en_s (D1)	ON openload detection
0	0	enable with bulb threshold (default)
0	1	enable with LED threshold
1	X	disable

A logic [1] on bit D0 (CSNS\_ratio\_s) selects the high ratio on the CSNS pin for the corresponding output. The default value [0] is the low ratio (Table 15).

**Table 15. Current sense ratio selection**

CSNS_high_s (D0)	Current sense ratio
0	CRS0 (default)
1	CRS1

### 6.4.2.5 Address A<sub>1</sub>A<sub>0</sub>100—Output overcurrent register (OCR)

The OCR\_s register allows the MCU to configure corresponding output overcurrent protection through the SPI. Each output “s” is independently selected for configuration based on the state of the D14:D13 bits (Table 12).

A logic [1] on bit D8 (Xenon\_s) disables the Xenon bulb overcurrent profile, as described Figure 17.

Xenon bit set to logic [0]:

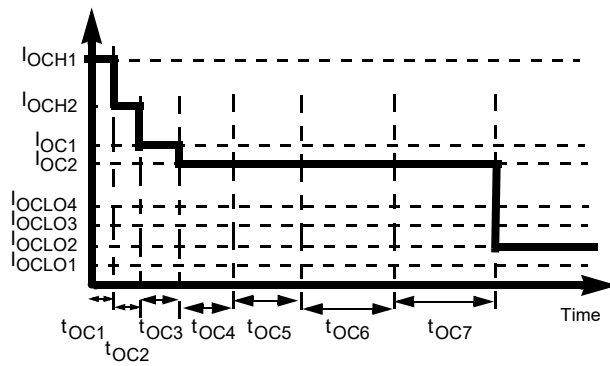

Xenon bit set to logic [1]:

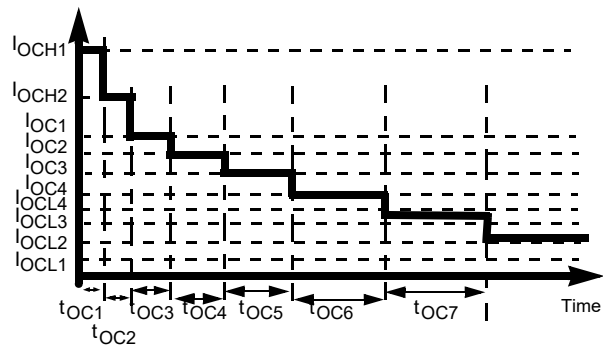

**Figure 17. Overcurrent profile depending on xenon bit**

D[7:6] bits allow to MCU to programmable bulb cooling curve and D[5:4] bits inrush curve for selected output, as shown [Table 16](#) and [Table 17](#).

**Table 16. Cooling curve selection**

BC1_s (D7)	BC0_s (D6)	Profile curves speed
0	0	medium (default)
0	1	slow
1	0	fast
1	1	medium

**Table 17. Inrush curve selection**

OC1_s (D5)	OC0_s (D4)	Profile curves speed
0	0	slow (default)
0	1	fast
1	0	medium
1	1	very slow

A logic [1] on bit D3 (OCHI\_s bit) the OCHI1 level is replaced by OCHI2 during  $t_{OC1}$ , as shown [Figure 18](#).

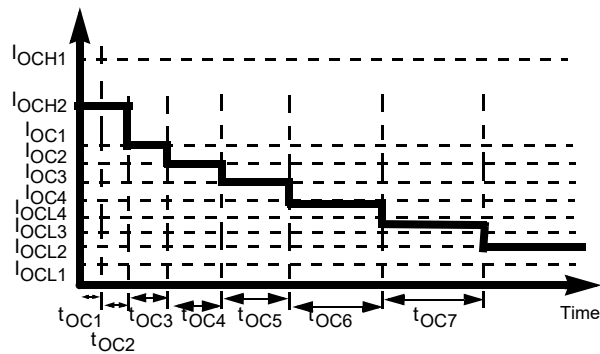

**Figure 18. Overcurrent profile with OCHI bit set to '1'**

The wire harness is protected by one of four possible current levels in steady state, as defined in [Table 18](#).

**Table 18. Output steady state selection**

OCLO1 (D2)	OCLO0 (D1)	Steady state current
0	0	OCLO2 (default)
0	1	OCLO3
1	0	OCLO4
1	1	OCLO1

Bit D0 (OC\_mode\_sel) allows to select the overcurrent mode, as described [Table 19](#).

**Table 19. Overcurrent mode selection**

OC_mode_s (D0)	Overcurrent mode
0	only inrush current management (default)
1	inrush current and bulb cooling management

### 6.4.2.6 Address 00101—Global configuration register (GCR)

The GCR register allows the MCU to configure the device through the SPI.

Bit D8 allows the MCU to enable or disable the  $V_{DD}$  failure detector. A logic [1] on VDD\_FAIL\_en bit allows switch of the outputs HS[0:1] with PWMR register device in Fail-safe mode in case of  $V_{DD} < V_{DD(FAIL)}$ .

Bit D7 allows the MCU to enable or disable the PWM module. A logic [1] on PWM\_en bit allows control of the outputs HS[0:1] with PWMR register (the direct input states are ignored).

Bit D6 (CLOCK\_sel) allows to select the clock used as reference by PWM module, as described in the following [Table 20](#).

**Table 20. PWM module selection**

PWM_en (D7)	CLOCK_sel (D6)	PWM module
0	X	PWM module disabled (default)
1	0	PWM module enabled with external clock from CLOCK
1	1	PWM module enabled with internal calibrated clock

Bits D5:D4 allow the MCU to select one of two analog feedback on CSNS output pin, as shown in [Table 21](#).

**Table 21. CSNS reporting selection**

TEMP_en (D5)	CSNS_en (D4)	CSNS reporting
0	0	CSNS tri-stated (default)
X	1	current recopy of selected output (D3:2] bits)
1	0	temperature on GND flag

**Table 22. Output current recopy selection**

CSNS1 (D3)	CSNS0 (D2)	CSNS reporting
1	0	HS0
1	1	HS1

The GCR register disables the overvoltage protection (D0). When this bit is [0], the overvoltage is enabled (default value).

### 6.4.2.7 Address 00111—Calibration register (CALR)

The CALR register allows the MCU to calibrate internal clock, as explained in [Figure 16](#).

### 6.4.3 Serial output communication (device status return data)

When the CSB pin is pulled low, the output register is loaded. Meanwhile, the data is clocked out MSB- (OD15-) first as the new message data is clocked into the SI pin. The first sixteen bits of data clocking out of the SO, and following a CSB transition, is dependent upon the previously written SPI word.

Any bits clocked out of the Serial Output (SO) pin after the first 16 bits are representative of the initial message bits clocked into the SI pin since the CSB pin first transitioned to a logic [0]. This feature is useful for daisy-chaining devices as well as message verification.

A valid message length is determined following a CSB transition of [0] to [1]. If there is a valid message length, the data is latched into the appropriate registers. A valid message length is a multiple of 16 bits. At this time, the SO pin is tri-stated and the fault status register is now able to accept new fault status information.

SO data represents information ranging from fault status to register contents, user selected by writing to the STATR bits OD4, OD3, OD2, OD1, and OD0. The value of the previous bit SOA3 determines which output the SO information applies to for the registers which are output specific; viz., Fault, PWMR, CONFR0, CONFR1, and OCR registers.

Note that the SO data continues to reflect the information for each output that was selected during the most recent STATR write until changed with an updated STATR write.

The output status register correctly reflects the status of the STATR-selected register data at the time that the CSB is pulled to a logic [0] during SPI communication, and/or for the period of time since the last valid SPI communication, with the following exception:

- The previous SPI communication was determined to be invalid. In this case, the status is reported as though the invalid SPI communication never occurred
- The  $V_{PWR}$  voltage is below 4.0 V, the status must be ignored by the MCU

### 6.4.4 Serial output bit assignment

The 16 bits of serial output data depend on the previous serial input message, as explained in the following paragraph. [Table 23](#), summarizes SO returned data for bits OD15:OD0.

- Bit OD15 is the MSB; it reflects the state of the watchdog bit from the previously clocked-in message
- Bits OD14:OD10 reflect the state of the bits SOA4:SOA0 from the previously clocked in message
- Bit OD9 is set to logic [1] in Normal mode (NM)
- The contents of bits OD8:OD0 depend on bits D4:D0 from the most recent STATR command SOA4:SOA0 as explained in the paragraph following [Table 23](#)

**Table 23. Serial output bit map description**

	Previous STATR					SO returned data															
	SOA4	SOA3	SOA2	SOA1	SOA0	OD15	OD14	OD13	OD12	OD11	OD10	OD9	OD8	OD7	OD6	OD5	OD4	OD3	OD2	OD1	OD0
STATR_s	1	A	0	0	0	WDI_N	SOA4	SOA3	SOA2	SOA1	SOA0	NM	POR	UV	OV	OLON_s	OLOFF_s	OS_s	OT_s	SC_s	OC_s
PWMR_s	1	A	0	0	1	WDI_N	SOA4	SOA3	SOA2	SOA1	SOA0	NM	0	ON_s	PWM6_s	PWM5_s	PWM4_s	PWM3_s	PWM2_s	PWM1_s	PWM0_s
CONFR0_s	1	A	0	1	0	WDI_N	SOA4	SOA3	SOA2	SOA1	SOA0	NM	X	X	X	DIR_dis_s	SR1_s	SR0_s	DELAY2_s	DELAY1_s	DELAY0_s
CONFR1_s	1	A	0	1	1	WDI_N	SOA4	SOA3	SOA2	SOA1	SOA0	NM	X	X	Retry_unlimited_s	Retry_dis_s	OS_dis_s	OLON_dis_s	OLOFF_dis_s	OLLED_en_s	CSNS_ratio_s
OCR_s	1	A	1	0	0	WDI_N	SOA4	SOA3	SOA2	SOA1	SOA0	NM	Xenon_s	BC1_s	BC0_s	OC1_s	OC0_s	OCHI_s	OCL01_s	OCL00_s	OC_mode_s
GCR	0	0	1	0	1	WDI_N	SOA4	SOA3	SOA2	SOA1	SOA0	NM	VDD_FAIL_en	PWM_en	CLOCK_sel	TEMP_en	CSNS_en	CSNS1	CSNS0	X	OV_dis
DIAGR0	0	0	1	1	1	WDI_N	SOA4	SOA3	SOA2	SOA1	SOA0	NM	X	X	X	X	X	X	CLOCK_fail	CAL_fail	OTW
DIAGR1	0	1	1	1	1	WDI_N	SOA4	SOA3	SOA2	SOA1	SOA0	NM	X	X	X	X	IN1	IN0	X	X	WD_en
DIAGR2	1	0	1	1	1	WDI_N	SOA4	SOA3	SOA2	SOA1	SOA0	NM	X	X	X	X	X	X	0	1	0
Register state after RST=0 or VDD(FAIL) or VSUPPLY(POR) condition	N/A	N/A	N/A	N/A	N/A	0	0	0	0	0	0	0	X	0	0	0	0	0	0	0	0

s=Output selection with the bit A as defined in Table 12

#### 6.4.4.1 Previous address SOA4:SOA0=1A000 (STATR\_S)

The returned data OD8 reports logic [1] in case of previous Power ON Reset condition (V<sub>SUPPLY(POR)</sub>). This bit is only reset by a read operation.

Bits OD7:OD0 reflect the current state of the Fault register (FLTR) corresponding to the output previously selected with the bits SOA3 = A (Table 23).

- OC\_s: overcurrent fault detection for a selected output,
- SC\_s: severe short-circuit fault detection for a selected output,
- OS\_s: output shorted to VPWR fault detection for a selected output,
- OLOFF\_s: openload in OFF state fault detection for a selected output,
- OLON\_s: openload in ON state fault detection (depending on current level threshold: bulb or LED) for a selected output,
- OV: overvoltage fault detection,
- UV: undervoltage fault detection
- POR: power on reset detection.

The FSB pin reports all faults. For latched faults, this pin is reset by a new Switch OFF command (toggling fault\_control signal).

#### 6.4.4.2 Previous address SOA4:SOA0=1A001 (PWMR\_S)

The returned data contains the programmed values in the PWMR register for the output selected with A.

#### 6.4.4.3 Previous address SOA4:SOA0=1A010 (CONFR0\_S)

The returned data contains the programmed values in the CONFR0 register for the output selected with A.

#### 6.4.4.4 Previous address SOA4:SOA0=1A011 (CONFR1\_S)

The returned data contains the programmed values in the CONFR1 register for the output selected with A.

#### 6.4.4.5 Previous address SOA4:SOA0=1A100 (OCR\_S)

The returned data contains the programmed values in the OCR register for the output selected with A.

#### 6.4.4.6 Previous address SOA4:SOA0=00101 (GCR)

The returned data contains the programmed values in the GCR register.

#### 6.4.4.7 Previous address SOA4:SOA0=00111 (DIAGR0)

The returned data OD2 reports logic [1] in case of PWM clock on CLOCK pin is out of specified frequency range.

The returned data OD1 reports logic [1] in case of calibration failure.

The returned data OD0 reports logic [1] in case of overtemperature prewarning (temperature of GND flag is above  $T_{OTWAR}$ ).

#### 6.4.4.8 Previous address SOA4:SOA0=01111 (DIAGR1)

The returned data OD4: OD3 report in real time the state of the direct input IN[1:0].

The OD0 indicates if the watchdog is enabled (set to logic [1]) or not (set to logic [0]). OD4:OD1 report the output state in case of Fail-safe state due to watchdog timeout as explained in the following [Table 24](#).

**Table 24. Watchdog activation report**

WD_en (OD0)	SPI watchdog
0	disabled
1	enabled

#### 6.4.4.9 Previous address SOA4:SOA0=10111 (DIAGR2)

The returned data is the product ID. Bits OD2:OD0 are set to 010 for protected dual 7.0 mΩ high-side switches.

### 6.4.5 Default device configuration

The default device configuration is explained by the following:

- HS output is commanded by the corresponding IN input or On bit through the SPI. The medium slew-rate is used.
- HS output is fully protected by the Xenon overcurrent profile by default, the severe short-circuit protection, the undervoltage and the overtemperature protection. The autoretry feature is enabled.
- openload in ON and OFF state and HS shorted to  $V_{PWR}$  detections are available
- No current recopy and no analog temperature feedback active
- Overvoltage protection is enabled
- SO reporting fault status must be ignored
- $V_{DD}$  failure detection is disabled



# 7 Typical applications

The following figure shows a typical automotive lighting application (only one vehicle corner) using an external PWM clock from the main MCU. A redundancy circuitry has been implemented to substitute light control (from MCU to watchdog) in case of a Fail-safe condition. It is recommended to locate a 22 nF decoupling capacitor to the module connector.

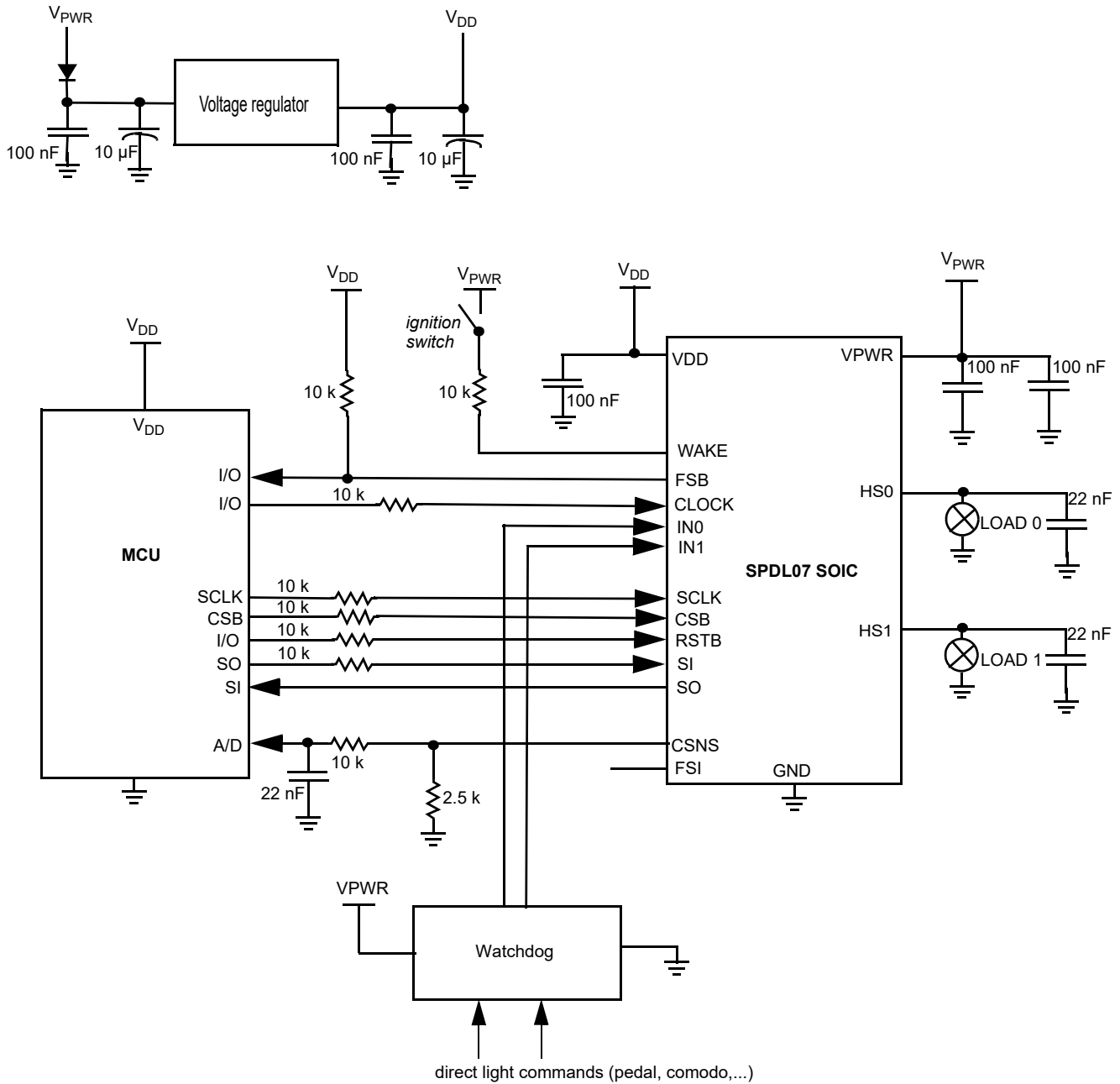

Figure 19. Typical application schematic

## 8 Packaging

### 8.1 Soldering information

The 07XS3200 is packaged in a surface mount power package intended to be soldered directly on the printed circuit board.

The 07XS3200 was qualified in accordance with JEDEC standards J-STD-020C Pb-Free reflow profile. The maximum peak temperature during the soldering process should not exceed 260 °C for 40 seconds maximum duration.

### 8.2 Package dimensions

Package dimensions are provided in package drawings. To find the most current package outline drawing, go to [www.nxp.com](http://www.nxp.com) and perform a keyword search for the drawing's document number.

Package	Suffix	Package outline drawing number
32-pin SOICW	EK	98ASA00368D

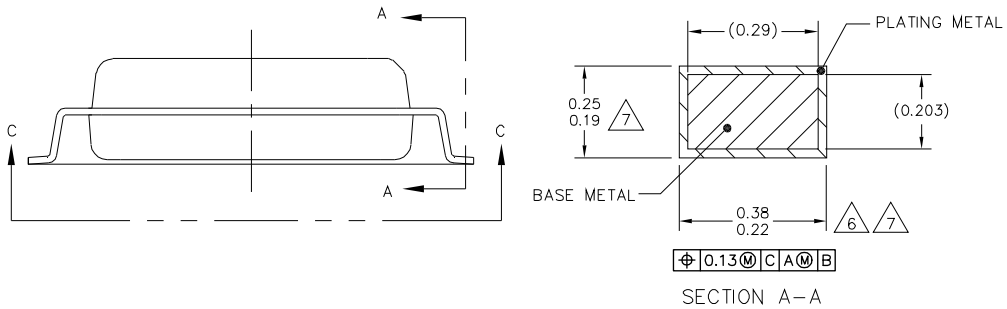
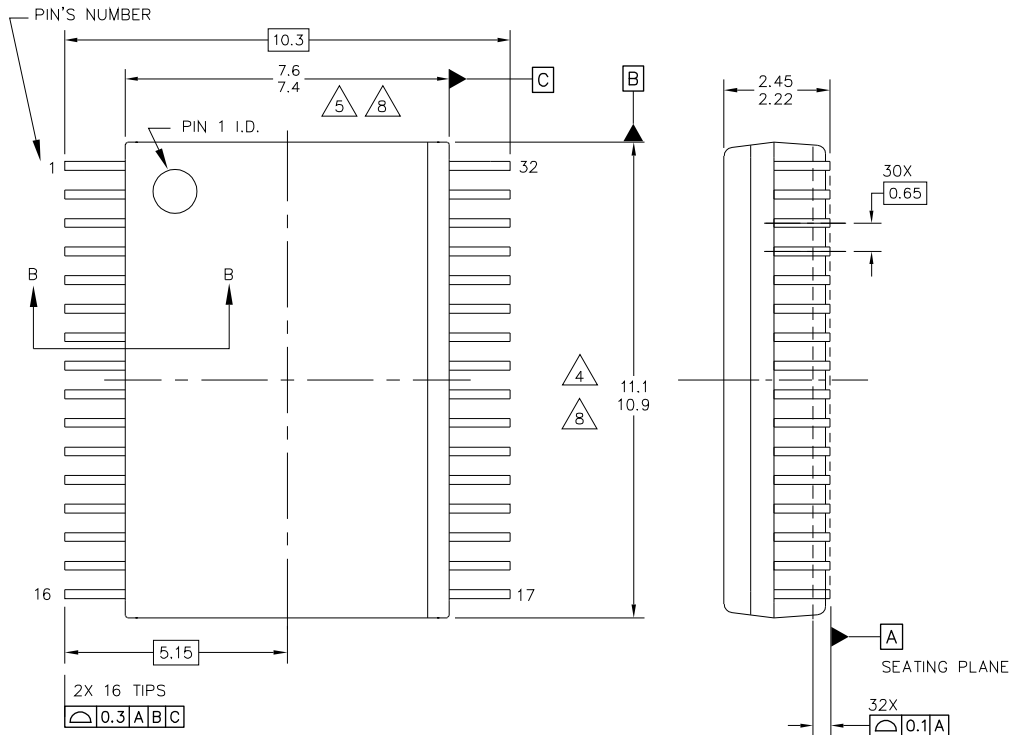

© NXP SEMICONDUCTORS N.V. ALL RIGHTS RESERVED	<b>MECHANICAL OUTLINE</b>	PRINT VERSION NOT TO SCALE
TITLE: SOIC W/B, 32 TERMINAL, 0.65 PITCH, 6.4 X 4.5 EXPOSED PAD	DOCUMENT NO: 98ASA00368D	REV: A
	STANDARD: NON-JEDEC	
	SOT1746-2	07 JAN 2016

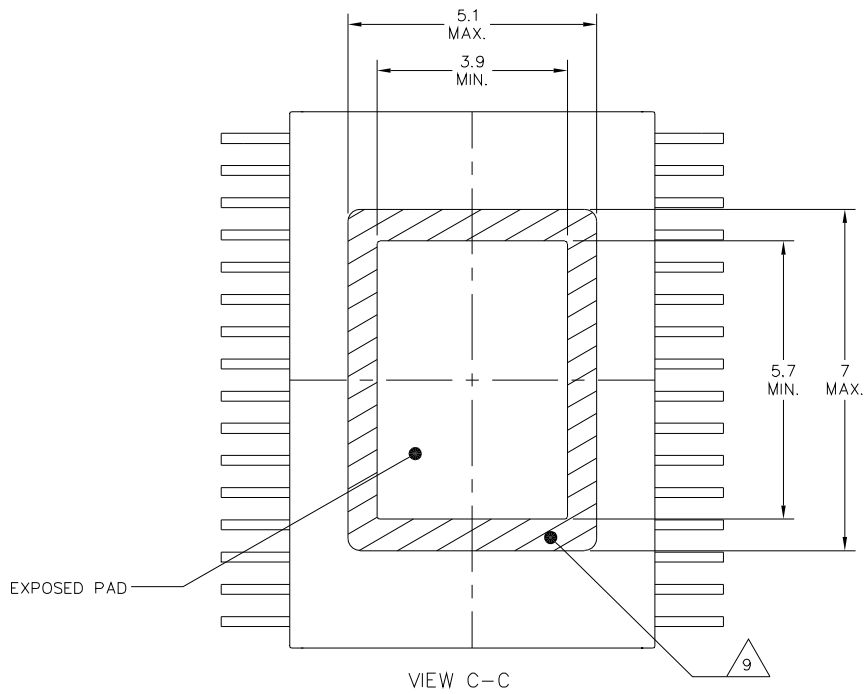
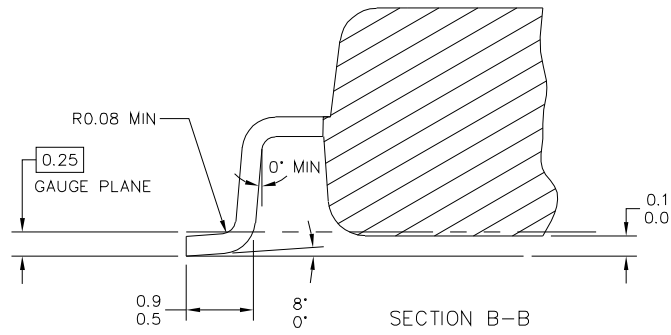

© NXP SEMICONDUCTORS N.V. ALL RIGHTS RESERVED	<b>MECHANICAL OUTLINE</b>	PRINT VERSION NOT TO SCALE
TITLE: SOIC W/B, 32 TERMINAL, 0.65 PITCH, 6.4 X 4.5 EXPOSED PAD	DOCUMENT NO: 98ASA00368D	REV: A
	STANDARD: NON-JEDEC	
	SOT1746-2	07 JAN 2016



NOTES:

1. DIMENSIONS ARE IN MILLIMETERS.
2. DIMENSIONING AND TOLERANCING PER ASME Y14.5M-1994.
3. DATUMS B AND C TO BE DETERMINED AT THE PLANE WHERE THE BOTTOM OF THE LEADS EXIT THE PLASTIC BODY.
4. THIS DIMENSION DOES NOT INCLUDE MOLD FLASH, PROTRUSION OR GATE BURRS. MOLD FLASH, PROTRUSION OR GATE BURRS SHALL NOT EXCEED 0.15 MM PER SIDE. THIS DIMENSION IS DETERMINED AT THE PLANE WHERE THE BOTTOM OF THE LEADS EXIT THE PLASTIC BODY.
5. THIS DIMENSION DOES NOT INCLUDE INTER-LEAD FLASH OR PROTRUSIONS. INTER-LEAD FLASH AND PROTRUSIONS SHALL NOT EXCEED 0.25 MM PER SIDE. THIS DIMENSION IS DETERMINED AT THE PLANE WHERE THE BOTTOM OF THE LEADS EXIT THE PLASTIC BODY.
6. THIS DIMENSION DOES NOT INCLUDE DAMBAR PROTRUSION. ALLOWABLE DAMBAR PROTRUSION SHALL NOT CAUSE THE LEAD WIDTH TO EXCEED 0.4 mm. DAMBAR CANNOT BE LOCATED ON THE LOWER RADIUS OR THE FOOT. MINIMUM SPACE BETWEEN PROTRUSION AND ADJACENT LEAD SHALL NOT LESS THAN 0.07 mm.
7. THESE DIMENSIONS APPLY TO THE FLAT SECTION OF THE LEAD BETWEEN 0.10 mm AND 0.3 mm FROM THE LEAD TIP.
8. THE PACKAGE TOP MAY BE SMALLER THAN THE PACKAGE BOTTOM. THIS DIMENSION IS DETERMINED AT THE OUTERMOST EXTREMES OF THE PLASTIC BODY EXCLUSIVE OF MOLD FLASH, TIE BAR BURRS, GATE BURRS AND INTER-LEAD FLASH, BUT INCLUDING ANY MISMATCH BETWEEN THE TOP AND BOTTOM OF THE PLASTIC BODY.
9. HATCHED AREA TO BE KEEP-OUT ZONE FOR PCB ROUTING.

© NXP SEMICONDUCTORS N.V. ALL RIGHTS RESERVED	<b>MECHANICAL OUTLINE</b>	PRINT VERSION NOT TO SCALE
TITLE: SOIC W/B, 32 TERMINAL, 0.65 PITCH, 6.4 X 4.5 EXPOSED PAD	DOCUMENT NO: 98ASA00368D	REV: A
	STANDARD: NON-JEDEC	
	SOT1746-2	07 JAN 2016

## 9 Revision history

Revision	Date	Description of Changes
1.0	2/2013	<ul style="list-style-type: none"> <li>Initial release</li> </ul>
2.0	6/2013	<ul style="list-style-type: none"> <li>Assigned final limits for HS[0,1] Current Sense Ratio, ON OpenLoad Fault Detection Current Threshold, HS[0:1] Outputs Turn-ON and OFF Delay Times, and HS[0:1] Driver Output Matching Time</li> <li>This revision was cancelled and not released</li> </ul>
3.0	9/2014	<ul style="list-style-type: none"> <li>Updated per GPCN 5352</li> <li>Corrected pinout on <a href="#">Figure 3</a> and <a href="#">Table 2</a></li> <li>Updated document format</li> </ul>
4.0	1/2016	<ul style="list-style-type: none"> <li>Deleted the 28W mode references as per PB 17069                             <ul style="list-style-type: none"> <li><a href="#">Table 4</a> - relabeled parameter descriptions, conditions, and symbols</li> <li><a href="#">Table 5</a> - relabeled parameter descriptions, conditions, and symbols</li> <li><a href="#">Table 11</a> - changed the PWMR_s D8 bit</li> <li><a href="#">Table 23</a> - changed the PWMR_s D8 bit</li> </ul> </li> <li>Added note <sup>(41)</sup> for <a href="#">Table 11</a></li> <li>Corrected errors in the revision history table</li> </ul>
	1/2016	<ul style="list-style-type: none"> <li>Corrected PB number</li> </ul>
	1/2016	<ul style="list-style-type: none"> <li>Detailed a description for the 28W mode change</li> </ul>
	7/2016	<ul style="list-style-type: none"> <li>Updated NXP document form and style</li> </ul>
5.0	8/2018	<ul style="list-style-type: none"> <li>Updated as per CIN 201808007I                             <ul style="list-style-type: none"> <li>Corrected T<sub>OLLED</sub> values in <a href="#">Table 5, Dynamic electrical characteristics</a></li> <li>Updated <a href="#">Openload detection in ON state for LED</a> (added clarification for the usage of openload LED function and changed D[6:0]=7F to D[7:0]=FF)</li> <li>Deleted 28 W references</li> </ul> </li> </ul>
6.0	1/2020	<ul style="list-style-type: none"> <li>Updated <a href="#">Figure 3</a> and pin description as per CIN 202001005I</li> </ul>

**How to Reach Us:****Home Page:**[NXP.com](http://www.nxp.com)**Web Support:**<http://www.nxp.com/support>

Information in this document is provided solely to enable system and software implementers to use NXP products.

There are no expressed or implied copyright licenses granted hereunder to design or fabricate any integrated circuits based on the information in this document. NXP reserves the right to make changes without further notice to any products herein.

NXP makes no warranty, representation, or guarantee regarding the suitability of its products for any particular purpose, nor does NXP assume any liability arising out of the application or use of any product or circuit, and specifically disclaims any and all liability, including without limitation, consequential or incidental damages. "Typical" parameters that may be provided in NXP data sheets and/or specifications can and do vary in different applications, and actual performance may vary over time. All operating parameters, including "typicals," must be validated for each customer application by the customer's technical experts. NXP does not convey any license under its patent rights nor the rights of others. NXP sells products pursuant to standard terms and conditions of sale, which can be found at the following address:

<http://www.nxp.com/terms-of-use.html>.

NXP, the NXP logo, Freescale, the Freescale logo and SMARTMOS are trademarks of NXP B.V. All other product or service names are the property of their respective owners. All rights reserved.

© 2020 NXP B.V.

Document Number: MC07XS3200

Rev. 6.0

1/2020

