



MAX11500 Evaluation Kit

Evaluates: MAX11500

General Description

The MAX11500 evaluation kit (EV kit) is a fully assembled and tested surface-mount printed-circuit board (PCB) that contains a MAX11500 IC. The MAX11500 is a 3-channel HD video filter for reconstruction and anti-aliasing applications. The filter's -3dB frequency is 33MHz. The MAX11500 includes a +6dB output buffer capable of driving a 2V_{P-P} video signal into a standard 150Ω load.

The MAX11500 EV kit can be configured for both AC- and DC-coupled inputs and outputs. The MAX11500 video inputs have 75Ω termination to ground and the outputs are 75Ω back terminated. The EV kit operates from a single 5V power supply.

Features

- ◆ Single 5V Supply Operation
- ◆ Output Buffer Drives a 150Ω Standard Video Load with a +6dB Gain
- ◆ High-Definition Video Filter
- ◆ AC- or DC-Coupled Inputs/Outputs
- ◆ Standard 75Ω Input/Output Terminations
- ◆ Surface-Mount Components
- ◆ Fully Assembled and Tested

Ordering Information

PART	TEMP RANGE	IC PACKAGE
MAX11500EVKIT+	0°C to +70°C*	8 SO

+Denotes a lead-free and RoHS-compliant EV kit.

*This limited temperature range applies to the EV kit PCB only. The MAX11500 IC temperature range is 0°C to +85°C.

Component List

DESIGNATION	QTY	DESCRIPTION
C1, C2, C3, C5	4	0.1μF ±10%, 25V X7R ceramic capacitors (0603) Murata GRM188R71E104K
C4	1	1μF ±10%, 25V X7R ceramic capacitor (0805) Murata GRM21BR71E105K
C6, C7, C8	3	220μF ±20%, 6.3V aluminum electrolytic capacitors (8.3mm x 8.3mm) SANYO 6SHPA220MAA
JU1–JU9	9	2-pin headers
R1, R4, R7	3	820kΩ ±5% resistors (0603)
R2, R5, R8	3	120kΩ ±5% resistors (0603)
R3, R6, R9–R12	6	75Ω ±1% resistors (0603)

DESIGNATION	QTY	DESCRIPTION
U1	1	MAX11500USA+ (8-pin SO)
GND, GND	2	PC mini-black test points
IN1, IN2, IN3, OUT1, OUT2, OUT3	6	PC mini-red test points
VIDIN1, VIDIN2, VIDIN3, VIDOUT1, VIDOUT2, VIDOUT3	6	75Ω BNC PCB-mount jack connectors
—	9	Shunts (JU1–JU9)
—	1	PCB: MAX11500 Evaluation Kit+

Component Suppliers

SUPPLIER	PHONE	WEBSITE
Murata Mfg. Co., Ltd.	770-436-1300	www.murata.com
SANYO North America Corp.	619-661-6835	www.sanyodevice.com

Note: Indicate that you are using the MAX11500 when contacting these component suppliers.

MAX11500 Evaluation Kit

Quick Start

Recommended Equipment

Before beginning, the following equipment is needed:

- 5V, 200mA DC power supply (V_{CC})
- Video signal generator (e.g., Tektronix TG-2000 or TG-700)
- Video measurement equipment (e.g., Tektronix VM-6000 or equivalent)

Procedure

The MAX11500 EV kit is fully assembled and tested. Follow the steps below to verify board operation.

Caution: Do not turn on the power supply until all connections are completed.

- 1) Connect the video signal generator output to the VIDIN_ BNC connectors on the MAX11500 EV kit.
- 2) Connect the VIDOUT_ BNC connectors on the EV kit to the input of the video measurement equipment.
- 3) Connect the power-supply ground to the GND pad on the EV kit.
- 4) Connect the 5V supply to the VCC pad on the EV kit.
- 5) Verify that no shunts are installed across jumpers JU1, JU3, JU5, JU7, JU8, and JU9 (AC-coupled inputs and outputs), and JU2 (no DC bias at VIDIN1).
- 6) Install shunts across jumpers JU4 and JU6 (DC bias for VIDIN2 and VIDIN3).
- 7) Set the video signal generator for the desired video input signal using a YPBPR signal format.
- 8) Connect the Y signal to the VIDIN1 BNC connector, and P_B and P_R to VIDIN2 and VIDIN3, respectively.
- 9) Turn on the power supply and enable the video signal generator output.
- 10) Analyze the video output signal with the video measurement equipment.

Detailed Description

The MAX11500 EV kit is a fully assembled and tested surface-mount PCB that contains a MAX11500 IC. The MAX11500 is a 3-channel video filter for reconstruction and anti-aliasing applications. All 3 channels have identical characteristics.

The MAX11500 filter's -3dB frequency is 33MHz. The device includes a +6dB output buffer capable of driving a 2V_{P-P} video signal into a standard 150Ω load. In the default configuration, the MAX11500 EV kit video inputs and outputs are set for AC-coupled operation.

The video inputs and outputs can also be configured for DC-coupled operation. The MAX11500 EV kit video inputs have a 75Ω termination to ground and the outputs are 75Ω back terminated.

Jumper Selection

AC-/DC-Coupled Input Operation

The MAX11500 features a transparent clamp at the video inputs that allows for either AC- or DC-coupling. If the input signal remains above ground, the transparent clamp is inactive, offering true DC-input coupling. If the signal goes below ground, it must be AC-coupled. The transparent clamp will set the sync tip just below ground.

Jumpers JU1, JU3, and JU5 set the MAX11500 EV kit video inputs for AC- or DC-coupled operation. For AC-coupled operation, remove shunts from jumpers JU1, JU3, and JU5. For DC-coupled operation, install shunts across jumpers JU1, JU3, or JU5. Use DC-coupling only for input signals whose lowest voltage is above ground. See Table 1 for proper jumper settings. When interfacing DC-coupled signals to the MAX11500 EV kit VIDIN_ inputs, verify that shunts are not installed across jumpers JU2, JU4, or JU6.

Table 1. AC-/DC-Coupled Input Operation (JU1, JU3, and JU5)

SHUNT POSITION	EV KIT INPUTS
Not installed	AC-coupled operation
Installed	DC-coupled operation

DC Bias for YPBPR Signals

When configuring the EV kit video inputs for AC-coupled operation, the correct DC bias point has to be chosen, depending on the input signal. Unipolar signals, such as R, G, B, and Y, are biased correctly using the MAX11500 internal transparent clamp. For bipolar signals, such as P_B and P_R signals, a constant DC bias voltage has to be applied after the AC-coupling capacitor to make sure that the clamp never operates. A 590mV DC bias voltage can be applied by installing shunts across jumpers JU2, JU4, or JU6. To configure the inputs to a different DC bias voltage, replace resistors R2, R5, or R8. See Table 2 for input clamp configuration.

Table 2. Input Clamp Operation (JU2, JU4, and JU6)

SHUNT POSITION	EV KIT FUNCTION
Installed	DC bias enabled: Use for P_B , P_R signals
Not installed	DC bias disabled: Use for R, G, B, Y signals

MAX11500 Evaluation Kit

AC-/DC-Coupled Output Operation

Jumpers JU7, JU8, and JU9 configure the MAX11500 EV kit video outputs for AC- or DC-coupled operation. To configure the outputs for AC-coupled operation, remove shunts from jumpers JU7, JU8, and JU9. To configure the outputs for DC-coupled operation, install shunts across jumpers JU7, JU8, and JU9. See Table 3 for the EV kit output configuration.

Table 3. AC-/DC-Coupled Output Operation (JU7, JU8, and JU9)

SHUNT POSITION	EV KIT OUTPUTS
Not installed	AC-coupled operation
Installed	DC-coupled operation

Evaluates: MAX11500

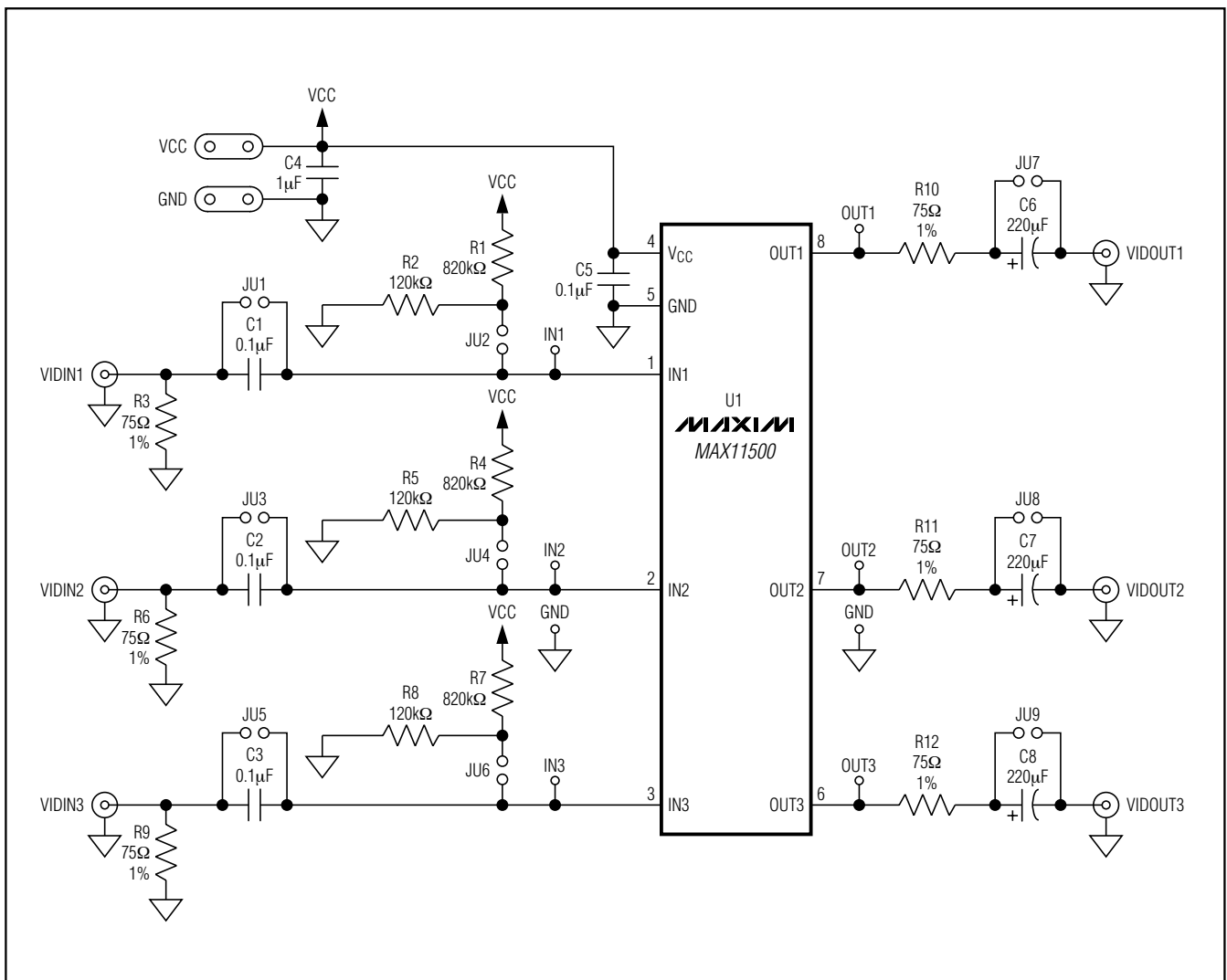

Figure 1. MAX11500 EV Kit Schematic

MAX11500 Evaluation Kit

Evaluates: MAX11500

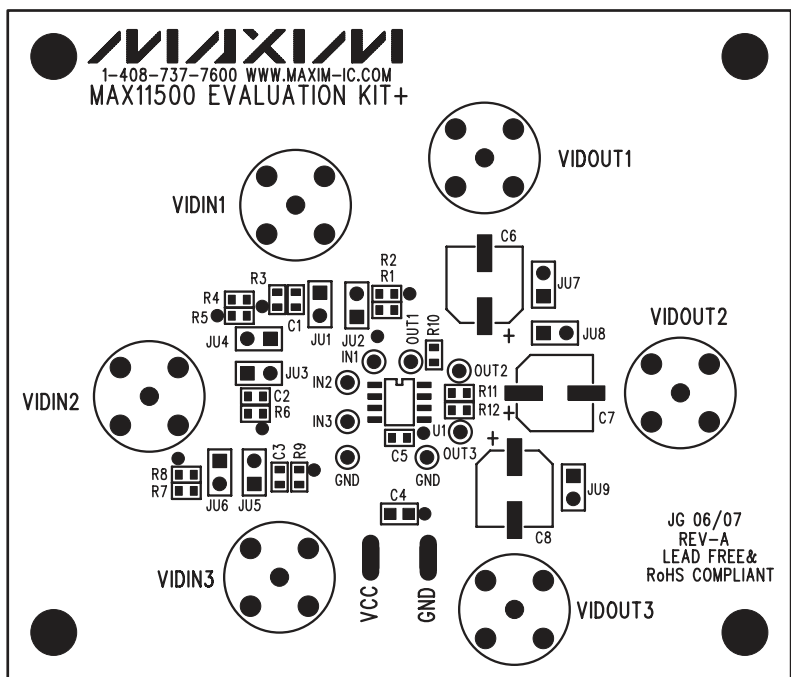

Figure 2. MAX11500 EV Kit Component Placement Guide—Component Side

MAX11500 Evaluation Kit

Evaluates: **MAX11500**

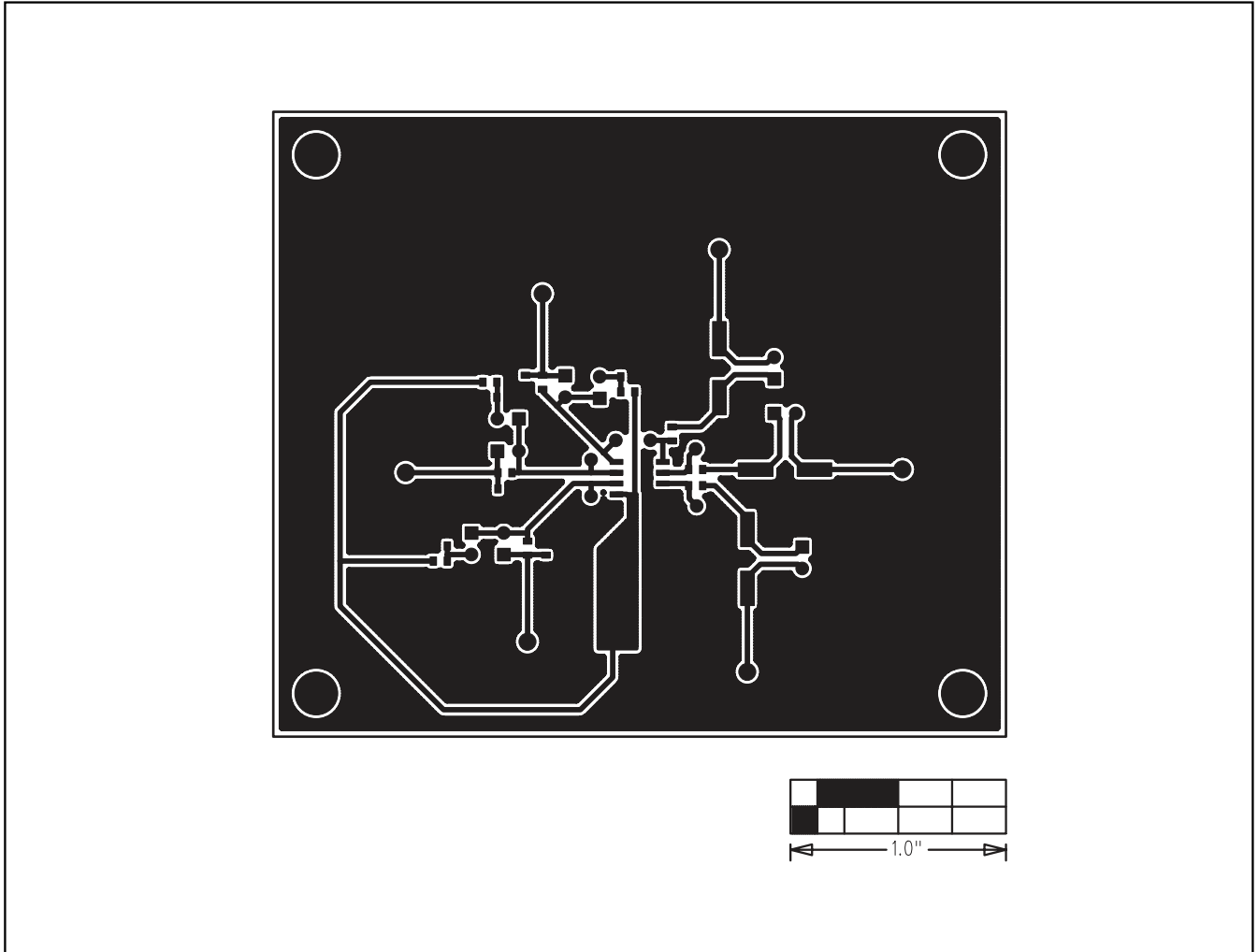

Figure 3. MAX11500 EV Kit PCB Layout—Component Side

MAX11500 Evaluation Kit

Evaluates: MAX11500

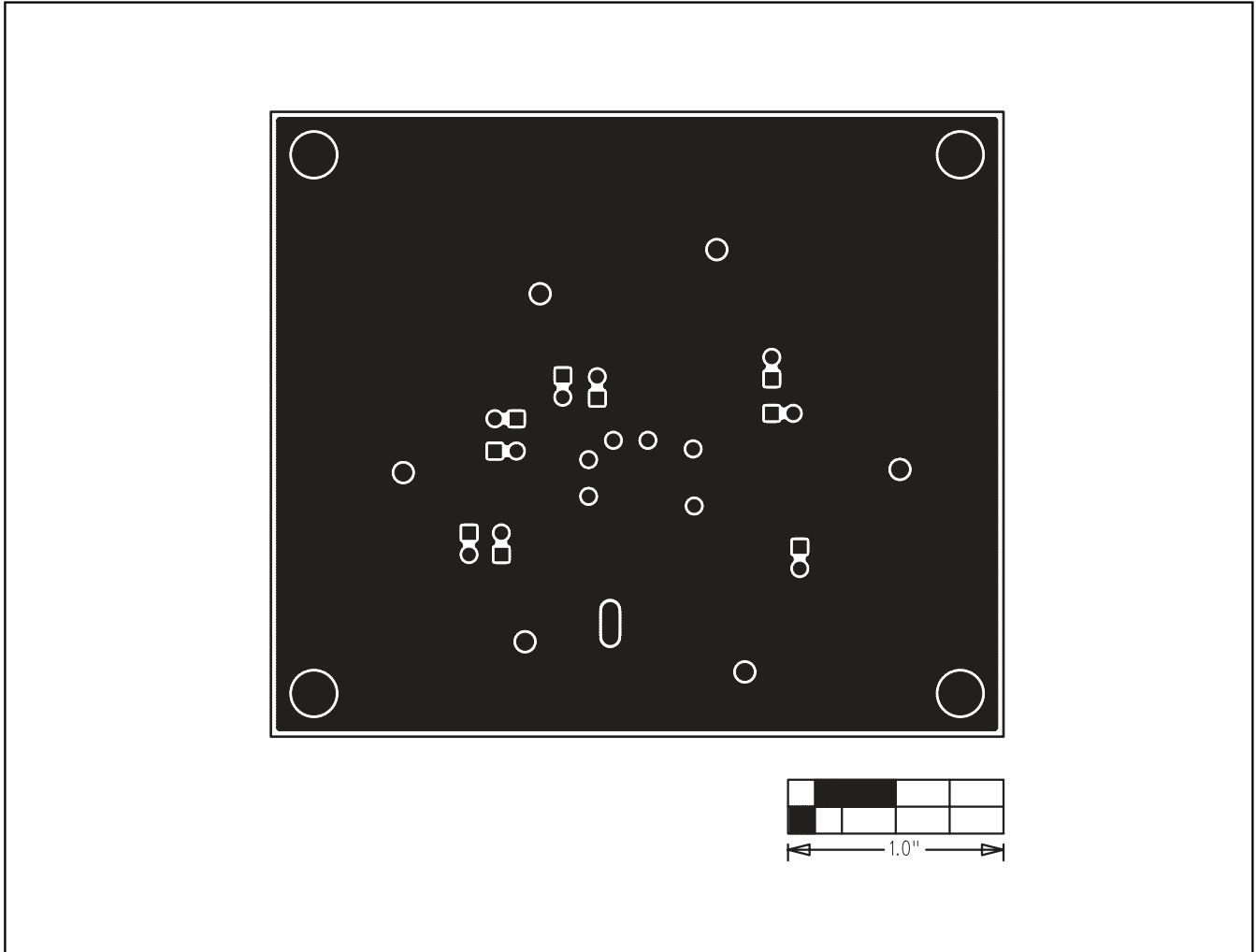

Figure 4. MAX11500 EV Kit PCB Layout—Solder Side

Maxim cannot assume responsibility for use of any circuitry other than circuitry entirely embodied in a Maxim product. No circuit patent licenses are implied. Maxim reserves the right to change the circuitry and specifications without notice at any time.

6 **Maxim Integrated Products, 120 San Gabriel Drive, Sunnyvale, CA 94086 408-737-7600**

© 2007 Maxim Integrated Products

MAXIM is a registered trademark of Maxim Integrated Products, Inc.