

FEATURES

- ◆ Fully integrated octal T1/E1 short haul line interface which supports 100 Ω T1 twisted pair, 120 Ω E1 twisted pair and 75 Ω E1 coaxial applications
- ◆ Selectable Single Rail mode or Dual Rail mode and AMI or B8ZS/HDB3 encoder/decoder
- ◆ Built-in transmit pre-equalization meets G.703 & T1.102
- ◆ Selectable transmit/receive jitter attenuator meets ETSI CTR12/13, ITU G.736, G.742, G.823 and AT&T Pub 62411 specifications
- ◆ SONET/SDH optimized jitter attenuator meets ITU G.783 mapping jitter specification
- ◆ Digital/Analog LOS detector meets ITU G.775, ETS 300 233 and T1.231
- ◆ ITU G.772 non-intrusive monitoring for in-service testing for any one of channel 1 to channel 7
- ◆ Low impedance transmit drivers with high-Z
- ◆ Selectable hardware and parallel/serial host interface
- ◆ Local, Remote and Inband Loopback test functions
- ◆ Hitless Protection Switching (HPS) for 1 to 1 protection without relays
- ◆ JTAG boundary scan for board test
- ◆ 3.3 V supply with 5 V tolerant I/O
- ◆ Low power consumption
- ◆ Operating temperature range: -40°C to +85°C
- ◆ Available in 144-pin Thin Quad Flat Pack (TQFP) and 160-pin Plastic Ball Grid Array (PBGA) packages
Green package options available

FUNCTIONAL BLOCK DIAGRAM

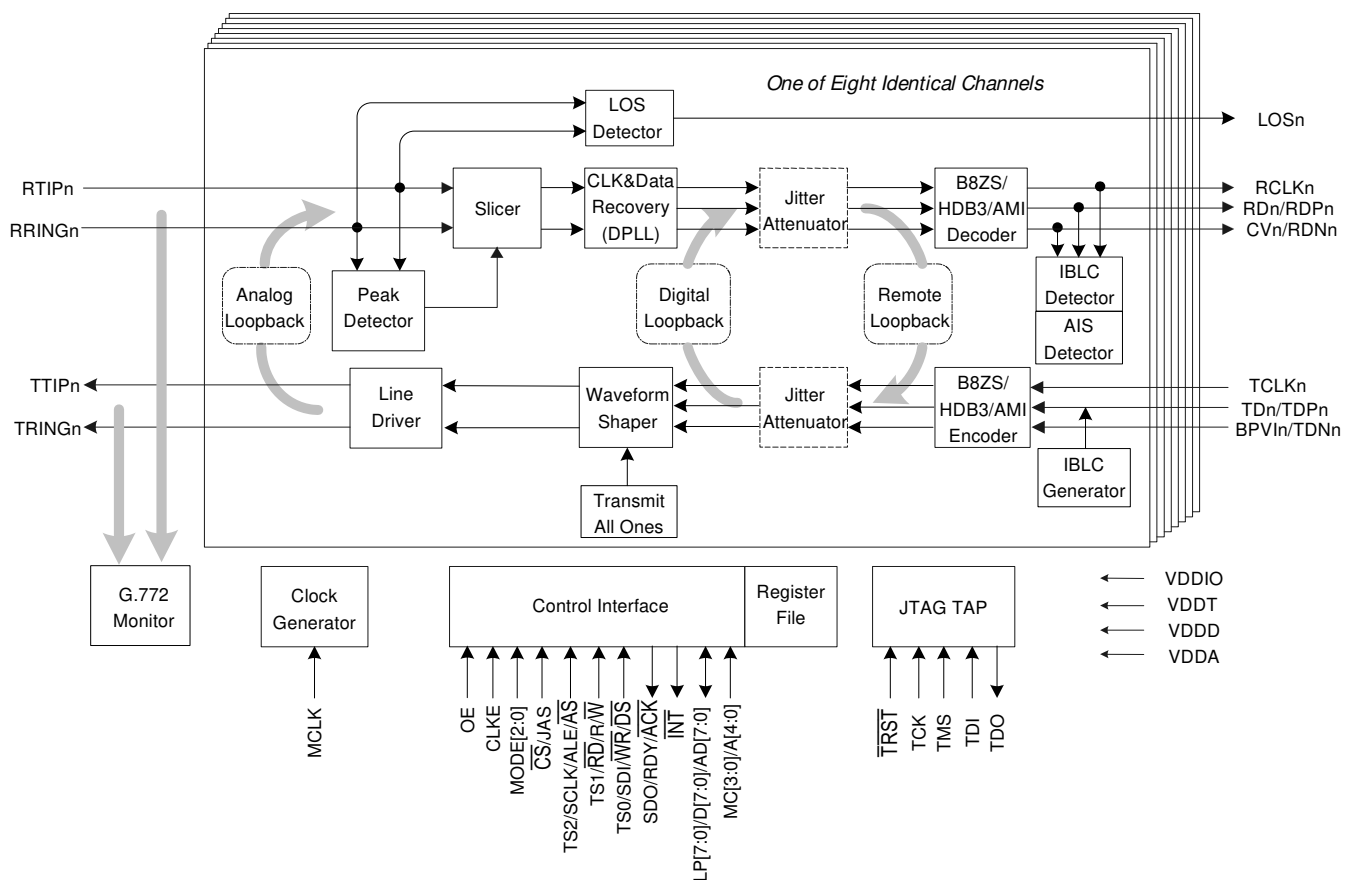

Figure-1 Block Diagram

DESCRIPTION

The IDT82V2048 is a single chip, 8-channel T1/E1 short haul PCM transceiver with a reference clock of 1.544 MHz (T1) or 2.048 MHz (E1). The IDT82V2048 contains 8 transmitters and 8 receivers.

All the receivers and transmitters can be programmed to work either in Single Rail mode or Dual Rail mode. B8ZS/HDB3 or AMI encoder/decoder is selectable in Single Rail mode. Pre-encoded transmit data in NRZ format can be accepted when the device is configured in Dual Rail mode. The receivers perform clock and data recovery by using integrated digital phase-locked loop. As an option, the raw sliced data (no retiming) can be output on the receive data pins. Transmit equalization is implemented with low-impedance output drivers that provide shaped waveforms to the transformer, guaranteeing template conformance.

A jitter attenuator is integrated in the IDT82V2048 and can be switched into either the transmit path or the receive path for all channels. The jitter attenuation performance meets ETSI CTR12/13, ITU G.736, G.742, G.823, and AT&T Pub 62411 specifications.

The IDT82V2048 offers hardware control mode and software control mode. Software control mode works with either serial host interface or parallel host interface. The latter works via an Intel/Motorola compatible 8-bit parallel interface for both multiplexed or non-multiplexed applications. Hardware control mode uses multiplexed pins to select different operation modes when the host interface is not available to the device.

The IDT82V2048 also provides loopback and JTAG boundary scan testing functions. Using the integrated monitoring function, the IDT82V2048 can be configured as a 7-channel transceiver with non-intrusive protected monitoring points.

The IDT82V2048 can be used for SDH/SONET multiplexers, central office or PBX, digital access cross connects, digital radio base stations, remote wireless modules and microwave transmission systems.

PIN CONFIGURATIONS

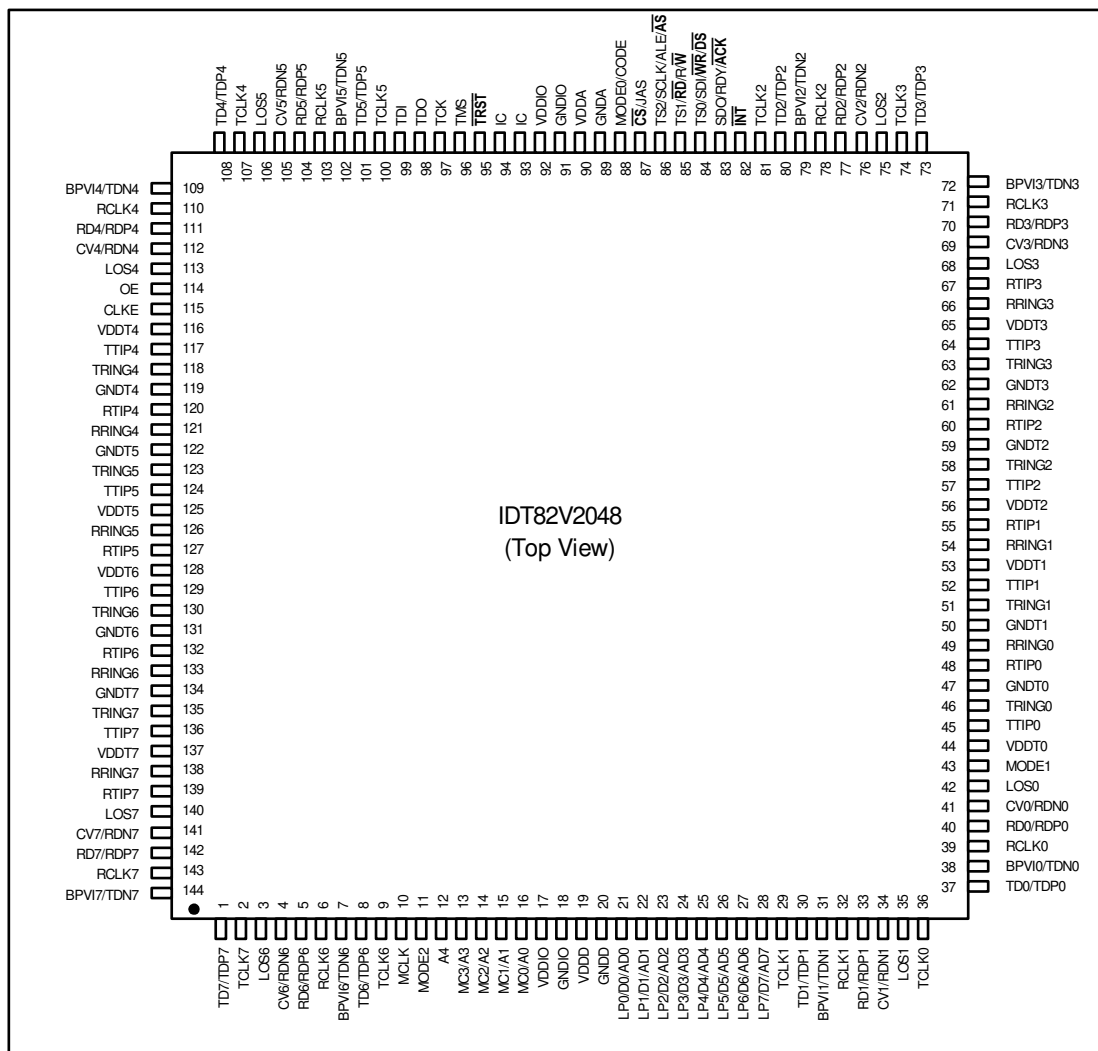

Figure-2 TQFP144 Package Pin Assignment

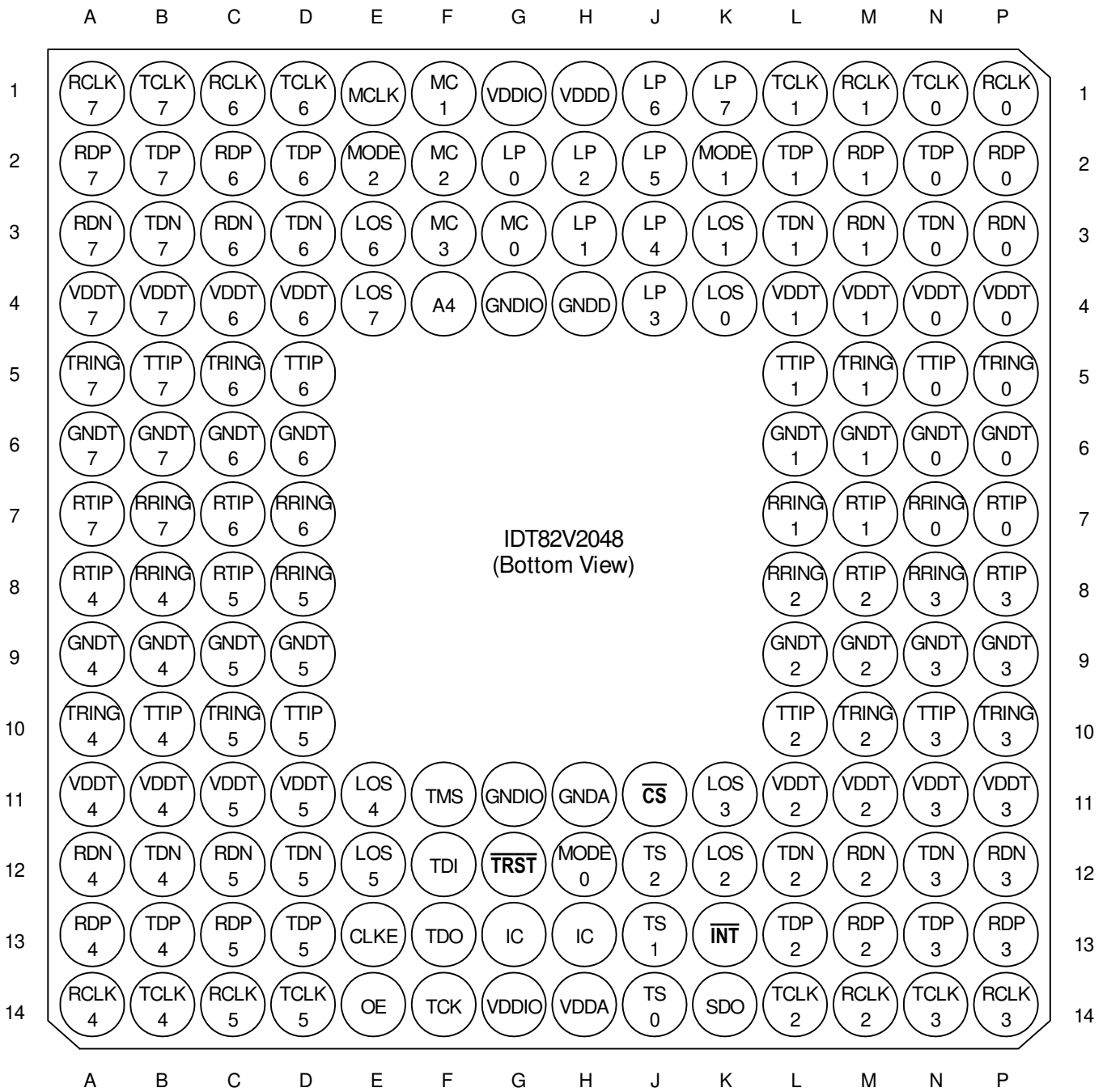

Figure-3 PBGA160 Package Pin Assignment

1 PIN DESCRIPTION

Table-1 Pin Description

Name	Type	Pin No.		Description
		TQFP144	PBGA160	
Transmit and Receive Line Interface				
TTIP0	Analog Output	45	N5	TTIPn/TRINGn: Transmit Bipolar Tip/Ring for Channel 0~7 These pins are the differential line driver outputs. They will be in high-Z if pin OE is low or the corresponding pin TCLKn is low (pin OE is global control, while pin TCLKn is per-channel control). In host mode, each pin can be in high-Z by programming a '1' to the corresponding bit in register OE ⁽¹⁾ .
TTIP1		52	L5	
TTIP2		57	L10	
TTIP3		64	N10	
TTIP4		117	B10	
TTIP5		124	D10	
TTIP6		129	D5	
TTIP7		136	B5	
TRING0		46	P5	
TRING1		51	M5	
TRING2		58	M10	
TRING3		63	P10	
TRING4		118	A10	
TRING5		123	C10	
TRING6	130	C5		
TRING7	135	A5		
RTIP0	Analog Input	48	P7	RTIPn/RRINGn: Receive Bipolar Tip/Ring for Channel 0~7 These pins are the differential line receiver inputs.
RTIP1		55	M7	
RTIP2		60	M8	
RTIP3		67	P8	
RTIP4		120	A8	
RTIP5		127	C8	
RTIP6		132	C7	
RTIP7		139	A7	
RRING0		49	N7	
RRING1		54	L7	
RRING2		61	L8	
RRING3		66	N8	
RRING4		121	B8	
RRING5		126	D8	
RRING6	133	D7		
RRING7	138	B7		

¹. Register name is indicated by bold capital letter. For example, OE indicates Output Enable Register.

Table-1 Pin Description (Continued)

Name	Type	Pin No.		Description																													
		TQFP144	PBGA160																														
Transmit and Receive Digital Data Interface																																	
TD0/TDP0 TD1/TDP1 TD2/TDP2 TD3/TDP3 TD4/TDP4 TD5/TDP5 TD6/TDP6 TD7/TDP7	I	37 30 80 73 108 101 8 1	N2 L2 L13 N13 B13 D13 D2 B2	<p>TDn: Transmit Data for Channel 0~7 When the device is in Single Rail mode, the NRZ data to be transmitted is input on this pin. Data on TDn is sampled into the device on the falling edges of TCLKn, and encoded by AMI or B8ZS/HDB3 line code rules before being transmitted to the line.</p> <p>BPVIn: Bipolar Violation Insertion for Channel 0~7 Bipolar violation insertion is available in Single Rail mode 2 (see Table-2 on page 13 and Table-3 on page 14) with AMI enabled. A low-to-high transition on this pin will make the next logic one to be transmitted on TDn the same polarity as the previous pulse, and violate the AMI rule. This is for testing.</p> <p>TDPn/TDNn: Positive/Negative Transmit Data for Channel 0~7 When the device is in Dual Rail Mode, the NRZ data to be transmitted for positive/negative pulse is input on this pin. Data on TDPn/TDNn are sampled on the falling edges of TCLKn. The line code in dual rail mode is as the follow:</p> <table border="1" style="margin-left: auto; margin-right: auto;"> <thead> <tr> <th>TDPn</th> <th>TDNn</th> <th>Output Pulse</th> </tr> </thead> <tbody> <tr> <td>0</td> <td>0</td> <td>Space</td> </tr> <tr> <td>0</td> <td>1</td> <td>Negative Pulse</td> </tr> <tr> <td>1</td> <td>0</td> <td>Positive Pulse</td> </tr> <tr> <td>1</td> <td>1</td> <td>Space</td> </tr> </tbody> </table> <p>Pulling pin TDNn high for more than 16 consecutive TCLK clock cycles will configure the corresponding channel into Single Rail mode 1 (see Table-2 on page 13 and Table-3 on page 14).</p>	TDPn	TDNn	Output Pulse	0	0	Space	0	1	Negative Pulse	1	0	Positive Pulse	1	1	Space														
TDPn		TDNn	Output Pulse																														
0		0	Space																														
0		1	Negative Pulse																														
1		0	Positive Pulse																														
1		1	Space																														
BPVI0/TDN0 BPVI1/TDN1 BPVI2/TDN2 BPVI3/TDN3 BPVI4/TDN4 BPVI5/TDN5 BPVI6/TDN6 BPVI7/TDN7		38 31 79 72 109 102 7 144	N3 L3 L12 N12 B12 D12 D3 B3																														
TCLK0 TCLK1 TCLK2 TCLK3 TCLK4 TCLK5 TCLK6 TCLK7		I	36 29 81 74 107 100 9 2	N1 L1 L14 N14 B14 D14 D1 B1	<p>TCLKn: Transmit Clock for Channel 0~7 The clock of 1.544 MHz (for T1 mode) or 2.048 MHz (for E1 mode) for transmit is input on this pin. The transmit data at TDn/TDPn or TDNn is sampled into the device on the falling edges of TCLKn. Pulling TCLKn high for more than 16 MCLK cycles, the corresponding transmitter is set in Transmit All Ones (TAOS) state (when MCLK is clocked). In TAOS state, the TAOS generator adopts MCLK as the clock reference. If TCLKn is low, the corresponding transmit channel is set into power down state, while driver output ports become high-Z. Different combinations of TCLKn and MCLK result in different transmit mode. It is summarized as the follows:</p> <table border="1" style="margin-left: auto; margin-right: auto;"> <thead> <tr> <th>MCLK</th> <th>TCLKn</th> <th colspan="2">Transmit Mode</th> </tr> </thead> <tbody> <tr> <td>Clocked</td> <td>Clocked</td> <td colspan="2">Normal operation</td> </tr> <tr> <td>Clocked</td> <td>High (≥ 16 MCLK)</td> <td colspan="2">Transmit All Ones (TAOS) signals to the line side in the corresponding transmit channel.</td> </tr> <tr> <td>Clocked</td> <td>Low (≥ 64 MCLK)</td> <td colspan="2">The corresponding transmit channel is set into power down state.</td> </tr> <tr> <td rowspan="3">High/Low</td> <td rowspan="3">TCLK1 is clocked</td> <td>TCLKn is clocked</td> <td>Normal operation</td> </tr> <tr> <td>TCLKn is high (≥ 16 TCLK1)</td> <td>Transmit All Ones (TAOS) signals to the line side in the corresponding transmit channel.</td> </tr> <tr> <td>TCLKn is low (≥ 64 TCLK1)</td> <td>Corresponding transmit channel is set into power down state.</td> </tr> <tr> <td>High/Low</td> <td>TCLK1 is unavailable.</td> <td colspan="2">All eight transmitters (TTIPn & TRINGn) will be in high-Z.</td> </tr> </tbody> </table>	MCLK	TCLKn	Transmit Mode		Clocked	Clocked	Normal operation		Clocked	High (≥ 16 MCLK)	Transmit All Ones (TAOS) signals to the line side in the corresponding transmit channel.		Clocked	Low (≥ 64 MCLK)	The corresponding transmit channel is set into power down state.		High/Low	TCLK1 is clocked	TCLKn is clocked	Normal operation	TCLKn is high (≥ 16 TCLK1)	Transmit All Ones (TAOS) signals to the line side in the corresponding transmit channel.	TCLKn is low (≥ 64 TCLK1)	Corresponding transmit channel is set into power down state.	High/Low	TCLK1 is unavailable.	All eight transmitters (TTIPn & TRINGn) will be in high-Z.	
MCLK			TCLKn	Transmit Mode																													
Clocked			Clocked	Normal operation																													
Clocked			High (≥ 16 MCLK)	Transmit All Ones (TAOS) signals to the line side in the corresponding transmit channel.																													
Clocked			Low (≥ 64 MCLK)	The corresponding transmit channel is set into power down state.																													
High/Low			TCLK1 is clocked	TCLKn is clocked	Normal operation																												
				TCLKn is high (≥ 16 TCLK1)	Transmit All Ones (TAOS) signals to the line side in the corresponding transmit channel.																												
	TCLKn is low (≥ 64 TCLK1)			Corresponding transmit channel is set into power down state.																													
High/Low	TCLK1 is unavailable.	All eight transmitters (TTIPn & TRINGn) will be in high-Z.																															

Table-1 Pin Description (Continued)

Name	Type	Pin No.		Description
		TQFP144	PBGA160	
RD0/RDP0 RD1/RDP1 RD2/RDP2 RD3/RDP3 RD4/RDP4 RD5/RDP5 RD6/RDP6 RD7/RDP7	O	40 33 77 70 111 104 5 142	P2 M2 M13 P13 A13 C13 C2 A2	<p>RDn: Receive Data for Channel 0~7 In Single Rail mode, the received NRZ data is output on this pin. The data is decoded by AMI or B8ZS/HDB3 line code rule.</p> <p>CVn: Code Violation for Channel 0~7 In Single Rail mode, the bipolar violation, code violation and excessive zeros will be reported by driving pin CVn high for a full clock cycle. However, only bipolar violation is indicated when AMI decoder is selected.</p> <p>RDPn/RDNn: Positive/Negative Receive Data for Channel 0~7 In Dual Rail Mode with clock recovery, these pins output the NRZ data. A high signal on RDPn indicates the receipt of a positive pulse on RTIPn/RRINGn while a high signal on RDNn indicates the receipt of a negative pulse on RTIPn/RRINGn.</p>
CV0/RDN0 CV1/RDN1 CV2/RDN2 CV3/RDN3 CV4/RDN4 CV5/RDN5 CV6/RDN6 CV7/RDN7	High-Z	41 34 76 69 112 105 4 141	P3 M3 M12 P12 A12 C12 C3 A3	<p>The output data at RDn or RDPn/RDNn are clocked out on the falling edges of RCLK when the CLKE input is low, or are clocked out on the rising edges of RCLK when CLKE is high.</p> <p>In Dual Rail Mode without clock recovery, these pins output the raw RZ sliced data. In this data recovery mode, the active polarity of RDPn/RDNn is determined by pin CLKE. When pin CLKE is low, RDPn/RDNn is active low. When pin CLKE is high, RDPn/RDNn is active high.</p> <p>In hardware mode, RDn or RDPn/RDNn will remain active during LOS. In host mode, these pins will either remain active or insert alarm indication signal (AIS) into the receive path, determined by bit AISE in register GCF.</p> <p>RDn or RDPn/RDNn is set into high-Z when the corresponding receiver is powered down.</p>
RCLK0 RCLK1 RCLK2 RCLK3 RCLK4 RCLK5 RCLK6 RCLK7	O High-Z	39 32 78 71 110 103 6 143	P1 M1 M14 P14 A14 C14 C1 A1	<p>RCLKn: Receive Clock for Channel 0~7 In clock recovery mode, this pin outputs the recovered clock from signal received on RTIPn/RRINGn. The received data are clocked out of the device on the rising edges of RCLKn if pin CLKE is high, or on falling edges of RCLKn if pin CLKE is low.</p> <p>In data recovery mode, RCLKn is the output of an internal exclusive OR (XOR) which is connected with RDPn and RDNn. The clock is recovered from the signal on RCLKn.</p> <p>If Receiver n is powered down, the corresponding RCLKn is in high-Z.</p>
MCLK	I	10	E1	<p>MCLK: Master Clock This is an independent, free running reference clock. A clock of 1.544 MHz (for T1 mode) or 2.048 MHz (for E1 mode) is supplied to this pin as the clock reference of the device for normal operation.</p> <p>In receive path, when MCLK is high, the device slices the incoming bipolar line signal into RZ pulse (Data Recovery mode). When MCLK is low, all the receivers are powered down, and the output pins RCLKn, RDPn and RDNn are switched to high-Z.</p> <p>In transmit path, the operation mode is decided by the combination of MCLK and TCLKn (see TCLKn pin description for details).</p> <p>NOTE: Wait state generation via $\overline{\text{RDY}}/\overline{\text{ACK}}$ is not available if MCLK is not provided.</p>
LOS0 LOS1 LOS2 LOS3 LOS4 LOS5 LOS6 LOS7	O	42 35 75 68 113 106 3 140	K4 K3 K12 K11 E11 E12 E3 E4	<p>LOSn: Loss of Signal Output for Channel 0~7 A high level on this pin indicates the loss of signal when there is no transition over a specified period of time or no enough ones density in the received signal. The transition will return to low automatically when there is enough transitions over a specified period of time with a certain ones density in the received signal. The LOS assertion and desertion criteria are described in 2.4.4 Loss of Signal (LOS) Detection.</p>

Table-1 Pin Description (Continued)

Name	Type	Pin No.		Description																		
		TQFP144	PBGA160																			
Hardware/Host Control Interface																						
MODE2	I (Pulled to VDDIO/2)	11	E2	<p>MODE2: Control Mode Select 2</p> <p>The signal on this pin determines which control mode is selected to control the device:</p> <table border="1"> <thead> <tr> <th>MODE2</th> <th>Control Interface</th> </tr> </thead> <tbody> <tr> <td>Low</td> <td>Hardware Mode</td> </tr> <tr> <td>VDDIO/2</td> <td>Serial Host Interface</td> </tr> <tr> <td>High</td> <td>Parallel Host Interface</td> </tr> </tbody> </table> <p>Hardware control pins include MODE[2:0], TS[2:0], LP[7:0], CODE, CLKE, JAS and OE. Serial host Interface pins include \overline{CS}, SCLK, SDI, SDO and \overline{INT}. Parallel host Interface pins include \overline{CS}, A[4:0], D[7:0], $\overline{WR/DS}$, $\overline{RD/RW}$, $\overline{ALE/AS}$, \overline{INT} and $\overline{RDY/ACK}$. The device supports multiple parallel host interface as follows (refer to MODE1 and MODE0 pin descriptions below for details):</p> <table border="1"> <thead> <tr> <th>MODE[2:0]</th> <th>Host Interface</th> </tr> </thead> <tbody> <tr> <td>100</td> <td>Non-multiplexed Motorola Mode Interface</td> </tr> <tr> <td>101</td> <td>Non-multiplexed Intel Mode Interface</td> </tr> <tr> <td>110</td> <td>Multiplexed Motorola Mode Interface</td> </tr> <tr> <td>111</td> <td>Multiplexed Intel Mode Interface</td> </tr> </tbody> </table>	MODE2	Control Interface	Low	Hardware Mode	VDDIO/2	Serial Host Interface	High	Parallel Host Interface	MODE[2:0]	Host Interface	100	Non-multiplexed Motorola Mode Interface	101	Non-multiplexed Intel Mode Interface	110	Multiplexed Motorola Mode Interface	111	Multiplexed Intel Mode Interface
MODE2	Control Interface																					
Low	Hardware Mode																					
VDDIO/2	Serial Host Interface																					
High	Parallel Host Interface																					
MODE[2:0]	Host Interface																					
100	Non-multiplexed Motorola Mode Interface																					
101	Non-multiplexed Intel Mode Interface																					
110	Multiplexed Motorola Mode Interface																					
111	Multiplexed Intel Mode Interface																					
MODE1	I	43	K2	<p>MODE1: Control Mode Select 1</p> <p>In parallel host mode, the parallel interface operates with separate address bus and data bus when this pin is low, and operates with multiplexed address and data bus when this pin is high. In serial host mode or hardware mode, this pin should be grounded.</p>																		
MODE0/CODE	I	88	H12	<p>MODE0: Control Mode Select 0</p> <p>In parallel host mode, the parallel host interface is configured for Motorola compatible hosts when this pin is low, or for Intel compatible hosts when this pin is high.</p> <p>CODE: Line Code Rule Select</p> <p>In hardware control mode, the B8ZS (for T1 mode)/HDB3 (for E1 mode) encoder/decoder is enabled when this pin is low, and AMI encoder/decoder is enabled when this pin is high. The selections affect all the channels. In serial host mode, this pin should be grounded.</p>																		
\overline{CS} /JAS	I (Pulled to VDDIO/2)	87	J11	<p>\overline{CS}: Chip Select (Active Low)</p> <p>In host mode, this pin is asserted low by the host to enable host interface. A high to low transition must occur on this pin for each read/write operation and the level must not return to high until the operation is over.</p> <p>JAS: Jitter Attenuator Select</p> <p>In hardware control mode, this pin globally determines the Jitter Attenuator position:</p> <table border="1"> <thead> <tr> <th>JAS</th> <th>Jitter Attenuator (JA) Configuration</th> </tr> </thead> <tbody> <tr> <td>Low</td> <td>JA in transmit path</td> </tr> <tr> <td>VDDIO/2</td> <td>JA not used</td> </tr> <tr> <td>High</td> <td>JA in receive path</td> </tr> </tbody> </table>	JAS	Jitter Attenuator (JA) Configuration	Low	JA in transmit path	VDDIO/2	JA not used	High	JA in receive path										
JAS	Jitter Attenuator (JA) Configuration																					
Low	JA in transmit path																					
VDDIO/2	JA not used																					
High	JA in receive path																					

Table-1 Pin Description (Continued)

Name	Type	Pin No.		Description
		TQFP144	PBGA160	
TS2/SCLK/ ALE/ \overline{AS}	I	86	J12	<p>TS2: Template Select 2 In hardware control mode, the signal on this pin is the most significant bit for the transmit template select. Refer to 2.5.1 Waveform Shaper for details.</p> <p>SCLK: Shift Clock In serial host mode, the signal on this pin is the shift clock for the serial interface. Data on pin SDO is clocked out on falling edges of SCLK if pin CLKE is high, or on rising edges of SCLK if pin CLKE is low. Data on pin SDI is always sampled on rising edges of SCLK.</p> <p>ALE: Address Latch Enable In parallel Intel multiplexed host mode, the address on AD[4:0] is sampled into the device on the falling edges of ALE (signals on AD[7:5] are ignored). In non-multiplexed host mode, ALE should be pulled high.</p> <p>\overline{AS}: Address Strobe (Active Low) In parallel Motorola multiplexed host mode, the address on AD[4:0] is latched into the device on the falling edges of \overline{AS} (signals on AD[7:5] are ignored). In non-multiplexed host mode, \overline{AS} should be pulled high.</p>
TS1/ \overline{RD} / \overline{RW}	I	85	J13	<p>TS1: Template Select 1 In hardware control mode, the signal on this pin is the second most significant bit for the transmit template select. Refer to 2.5.1 Waveform Shaper for details.</p> <p>\overline{RD}: Read Strobe (Active Low) In parallel Intel multiplexed or non-multiplexed host mode, this pin is active low for read operation.</p> <p>\overline{RW}: Read/Write Select In parallel Motorola multiplexed or non-multiplexed host mode, the pin is active low for write operation and high for read operation.</p>
TS0/SDI/ \overline{WR} / \overline{DS}	I	84	J14	<p>TS0: Template Select 0 In hardware control mode, the signal on this pin is the least significant bit for the transmit template select. Refer to 2.5.1 Waveform Shaper for details.</p> <p>SDI: Serial Data Input In serial host mode, this pin input the data to the serial interface. Data on this pin is sampled on the rising edges of SCLK.</p> <p>\overline{WR}: Write Strobe (Active Low) In parallel Intel host mode, this pin is active low during write operation. The data on D[7:0] (in non-multiplexed mode) or AD[7:0] (in multiplexed mode) is sampled into the device on the rising edges of \overline{WR}.</p> <p>\overline{DS}: Data Strobe (Active Low) In parallel Motorola host mode, this pin is active low. During a write operation ($\overline{RW} = 0$), the data on D[7:0] (in non-multiplexed mode) or AD[7:0] (in multiplexed mode) is sampled into the device on the rising edges of \overline{DS}. During a read operation ($\overline{RW} = 1$), the data is driven to D[7:0] (in non-multiplexed mode) or AD[7:0] (in multiplexed mode) by the device on the rising edges of \overline{DS}.</p> <p>In parallel Motorola non-multiplexed host mode, the address information on the 5 bits of address bus A[4:0] are latched into the device on the falling edges of \overline{DS}.</p>

Table-1 Pin Description (Continued)

Name	Type	Pin No.		Description								
		TQFP144	PBGA160									
SDO/RDY/ $\overline{\text{ACK}}$	O	83	K14	<p>SDO: Serial Data Output In serial host mode, the data is output on this pin. In serial write operation, SDO is in high impedance for the first 8 SCLK clock cycles and driven low for the remaining 8 SCLK clock cycles. In serial read operation, SDO is in high-Z only when SDI is in address/command byte. Data on pin SDO is clocked out of the device on the falling edges of SCLK if pin CLKE is high, or on the rising edges of SCLK if pin CLKE is low.</p> <p>RDY: Ready Output In parallel Intel host mode, the high level of this pin reports to the host that bus cycle can be completed, while low reports the host must insert wait states.</p> <p>$\overline{\text{ACK}}$: Acknowledge Output (Active Low) In parallel Motorola host mode, the low level of this pin indicates that valid information on the data bus is ready for a read operation or acknowledges the acceptance of the written data during a write operation.</p>								
$\overline{\text{INT}}$	O Open Drain	82	K13	<p>$\overline{\text{INT}}$: Interrupt (Active Low) This is an open drain, active low interrupt output. Four sources may cause the interrupt. Refer to 2.19 Interrupt Handling for details.</p>								
LP7/D7/AD7 LP6/D6/AD6 LP5/D5/AD5 LP4/D4/AD4 LP3/D3/AD3 LP2/D2/AD2 LP1/D1/AD1 LP0/D0/AD0	I/O High-Z	28 27 26 25 24 23 22 21	K1 J1 J2 J3 J4 H2 H3 G2	<p>LPn: Loopback Select 7~0 In hardware control mode, pin LPn configures the corresponding channel in different loopback mode, as follows:</p> <table border="1"> <thead> <tr> <th>LPn</th> <th>Loopback Configuration</th> </tr> </thead> <tbody> <tr> <td>Low</td> <td>Remote Loopback</td> </tr> <tr> <td>VDDIO/2</td> <td>No loopback</td> </tr> <tr> <td>High</td> <td>Analog Loopback</td> </tr> </tbody> </table> <p>Refer to 2.17 Loopback Mode for details.</p> <p>Dn: Data Bus 7~0 In non-multiplexed host mode, these pins are the bi-directional data bus.</p> <p>ADn: Address/Data Bus 7~0 In multiplexed host mode, these pins are the multiplexed bi-directional address/data bus.</p> <p>In serial host mode, these pins should be grounded.</p>	LPn	Loopback Configuration	Low	Remote Loopback	VDDIO/2	No loopback	High	Analog Loopback
LPn	Loopback Configuration											
Low	Remote Loopback											
VDDIO/2	No loopback											
High	Analog Loopback											

Table-1 Pin Description (Continued)

Name	Type	Pin No.		Description																																		
		TQFP144	PBGA160																																			
A4 MC3/A3 MC2/A2 MC1/A1 MC0/A0	I	12 13 14 15 16	F4 F3 F2 F1 G3	<p>MCn: Performance Monitor Configuration 3~0 In hardware control mode, A4 must be connected to GND. MC[3:0] are used to select one transmitter or receiver of channel 1 to 7 for non-intrusive monitoring. Channel 0 is used as the monitoring channel. If a transmitter is monitored, signals on the corresponding pins TTIPn and TRINGn are internally transmitted to RTIP0 and RRING0. If a receiver is monitored, signals on the corresponding pins RTIPn and RRINGn are internally transmitted to RTIP0 and RRING0. The monitored is then output to RDP0 and RDN0 pins. In host mode operation, the signals monitored by channel 0 can be routed to TTIP0/RING0 by activating the remote loopback in this channel. Refer to 2.20 G.772 Monitoring for more details.</p> <p>Performance Monitor Configuration determined by MC[3:0] is shown below. Note that if MC[2:0] = 000, the device is in normal operation of all the channels.</p> <table border="1"> <thead> <tr> <th>MC[3:0]</th> <th>Monitoring Configuration</th> </tr> </thead> <tbody> <tr> <td>0000</td> <td>Normal operation without monitoring</td> </tr> <tr> <td>0001</td> <td>Monitor Receiver 1</td> </tr> <tr> <td>0010</td> <td>Monitor Receiver 2</td> </tr> <tr> <td>0011</td> <td>Monitor Receiver 3</td> </tr> <tr> <td>0100</td> <td>Monitor Receiver 4</td> </tr> <tr> <td>0101</td> <td>Monitor Receiver 5</td> </tr> <tr> <td>0110</td> <td>Monitor Receiver 6</td> </tr> <tr> <td>0111</td> <td>Monitor Receiver 7</td> </tr> <tr> <td>1000</td> <td>Normal operation without monitoring</td> </tr> <tr> <td>1001</td> <td>Monitor Transmitter 1</td> </tr> <tr> <td>1010</td> <td>Monitor Transmitter 2</td> </tr> <tr> <td>1011</td> <td>Monitor Transmitter 3</td> </tr> <tr> <td>1100</td> <td>Monitor Transmitter 4</td> </tr> <tr> <td>1101</td> <td>Monitor Transmitter 5</td> </tr> <tr> <td>1110</td> <td>Monitor Transmitter 6</td> </tr> <tr> <td>1111</td> <td>Monitor Transmitter 7</td> </tr> </tbody> </table> <p>An: Address Bus 4~0 When pin MODE1 is low, the parallel host interface operates with separate address and data bus. In this mode, the signal on this pin is the address bus of the host interface.</p>	MC[3:0]	Monitoring Configuration	0000	Normal operation without monitoring	0001	Monitor Receiver 1	0010	Monitor Receiver 2	0011	Monitor Receiver 3	0100	Monitor Receiver 4	0101	Monitor Receiver 5	0110	Monitor Receiver 6	0111	Monitor Receiver 7	1000	Normal operation without monitoring	1001	Monitor Transmitter 1	1010	Monitor Transmitter 2	1011	Monitor Transmitter 3	1100	Monitor Transmitter 4	1101	Monitor Transmitter 5	1110	Monitor Transmitter 6	1111	Monitor Transmitter 7
MC[3:0]	Monitoring Configuration																																					
0000	Normal operation without monitoring																																					
0001	Monitor Receiver 1																																					
0010	Monitor Receiver 2																																					
0011	Monitor Receiver 3																																					
0100	Monitor Receiver 4																																					
0101	Monitor Receiver 5																																					
0110	Monitor Receiver 6																																					
0111	Monitor Receiver 7																																					
1000	Normal operation without monitoring																																					
1001	Monitor Transmitter 1																																					
1010	Monitor Transmitter 2																																					
1011	Monitor Transmitter 3																																					
1100	Monitor Transmitter 4																																					
1101	Monitor Transmitter 5																																					
1110	Monitor Transmitter 6																																					
1111	Monitor Transmitter 7																																					
OE	I	114	E14	<p>OE: Output Driver Enable Pulling this pin low can drive all driver output into high-Z for redundancy application without external mechanical relays. In this condition, all other internal circuits remain active.</p>																																		
CLKE	I	115	E13	<p>CLKE: Clock Edge Select The signal on this pin determines the active edge of RCLKn and SCLK in clock recovery mode, or determines the active level of RDPn and RDNn in the data recovery mode. See 2.3 Clock Edges on page 14 for details.</p>																																		
JTAG Signals																																						
$\overline{\text{TRST}}$	I Pull-up	95	G12	<p>$\overline{\text{TRST}}$: JTAG Test Port Reset (Active Low) This is the active low asynchronous reset to the JTAG Test Port. This pin has an internal pull-up resistor and it can be left open.</p>																																		
TMS	I Pull-up	96	F11	<p>TMS: JTAG Test Mode Select The signal on this pin controls the JTAG test performance and is clocked into the device on the rising edges of TCK. This pin has an internal pull-up resistor and it can be left open.</p>																																		
TCK	I	97	F14	<p>TCK: JTAG Test Clock This pin input the clock of the JTAG Test. The data on TDI and TMS are clocked into the device on the rising edges of TCK, while the data on TDO is clocked out of the device on the falling edges of TCK. This pin should be connected to GNDIO or VDDIO pin when unused.</p>																																		

Table-1 Pin Description (Continued)

Name	Type	Pin No.		Description
		TQFP144	PBGA160	
TDO	O High-Z	98	F13	TDO: JTAG Test Data Output This pin output the serial data of the JTAG Test. The data on TDO is clocked out of the device on the falling edges of TCK. TDO is a high-Z output signal. It is active only when scanning of data is out. This pin should be left float when unused.
TDI	I Pull-up	99	F12	TDI: JTAG Test Data Input This pin input the serial data of the JTAG Test. The data on TDI is clocked into the device on the rising edges of TCK. This pin has an internal pull-up resistor and it can be left open.
Power Supplies and Grounds				
VDDIO	-	17 92	G1 G14	3.3 V I/O Power Supply
GNDIO	-	18 91	G4 G11	I/O GND
VDDT0 VDDT1 VDDT2 VDDT3 VDDT4 VDDT5 VDDT6 VDDT7	-	44 53 56 65 116 125 128 137	N4, P4 L4, M4 L11, M11 N11, P11 A11, B11 C11, D11 C4, D4 A4, B4	3.3 V/5 V Power Supply for Transmitter Driver All VDDT pins must be connected to 3.3 V or all VDDT must be connected to 5 V. It is not allowed to leave any of the VDDT pins open (not-connected) even if the channel is not used. T1 is only 5V VDDT.
GNDT0 GNDT1 GNDT2 GNDT3 GNDT4 GNDT5 GNDT6 GNDT7	-	47 50 59 62 119 122 131 134	N6, P6 L6, M6 L9, M9 N9, P9 A9, B9 C9, D9 C6, D6 A6, B6	Analog GND for Transmitter Driver
VDDD VDDA	-	19 90	H1 H14	3.3 V Digital/Analog Core Power Supply
GNDD GNDA	-	20 89	H4 H11	Digital/Analog Core GND
Others				
IC	O	93 94	G13 H13	IC: Internal Connection Internal use. Leave it float for normal operation.

2 FUNCTIONAL DESCRIPTION

2.1 OVERVIEW

The IDT82V2048 is a fully integrated octal short-haul line interface unit, which contains eight transmit and receive channels for use in either T1 or E1 applications. The receiver performs clock and data recovery. As an option, the raw sliced data (no retiming) can be output to the system. Transmit equalization is implemented with low-impedance output drivers that provide shaped waveforms to the transformer, guaranteeing template conformance. A selectable jitter attenuator may be placed in the receive path or the transmit path. Moreover, multiple testing functions, such as error detection, loopback and JTAG boundary scan are also provided. The device is optimized for flexible software control through a serial or parallel host mode interface. Hardware control is also available. [Figure-1 on page 1](#) shows one of the eight identical channels operation.

2.2 T1/E1 MODE SELECTION

T1/E1 mode selection configures the device globally. In Hardware Mode, the template selection pins TS[2:0], determine whether the operation mode is T1 or E1 (see [Table-9 on page 19](#)). In Software Mode, the register TS determines whether the operation mode is T1 or E1.

2.2.1 SYSTEM INTERFACE

The system interface of each channel can be configured to operate in different modes:

1. Single rail interface with clock recovery.
2. Dual rail interface with clock recovery.
3. Dual rail interface with data recovery (that is, with raw data slicing only and without clock recovery).

Each signal pin on system side has multiple functions depending on which operation mode the device is in.

The Dual Rail interface consists of TDPn¹, TDNn, TCLKn, RDPn, RDNn and RCLKn. Data transmitted from TDPn and TDNn appears on TTIPn and TRINGn at the line interface; data received from the RTIPn and RRINGn at the line interface are transferred to RDPn and RDNn while the recovered clock extracting from the received data stream outputs on RCLKn. In Dual Rail operation, the clock/data recovery mode is selectable. Dual Rail interface with clock recovery shown in [Figure-4](#) is a default configuration mode. Dual Rail interface with data recovery is shown in [Figure-5](#). Pin RDPn and RDNn, are raw RZ slice outputs and internally connected to an EXOR which is fed to the RCLKn output for external clock recovery applications.

In Single Rail mode, data transmitted from TDn appears on TTIPn and TRINGn at the line interface. Data received from the RTIPn and RRINGn at the line interface appears on RDn while the recovered clock extracting from the received data stream outputs on RCLKn. When the device is in single rail interface, the selectable AMI or B8ZS/HDB3 line encoder/decoder is available and any code violation in the received data will be indicated at the CVn pin. The Single Rail mode has 2 sub-modes: Single Rail Mode 1 and Single Rail Mode 2. Single Rail Mode 1, whose interface is composed of TDn, TCLKn, RDn, CVn and RCLKn, is realized by pulling pin TDNn high for more than 16 consecutive TCLK cycles. Single Rail Mode 2, whose interface is composed of TDn, TCLKn, RDn, CVn, RCLKn and BPVIn, is realized by setting bit CRS in register e-CRS² and bit SING in register e-SING. The difference between them is that, in the latter mode bipolar violation can be inserted via pin BPVIn if AMI line code is selected.

The configuration of the Hardware Mode System Interface is summarized in [Table-2](#). The configuration of the Host Mode System Interface is summarized in [Table-3](#).

¹ The footprint 'n' (n = 0 - 7) indicates one of the eight channels.
² The first letter 'e-' indicates expanded register.

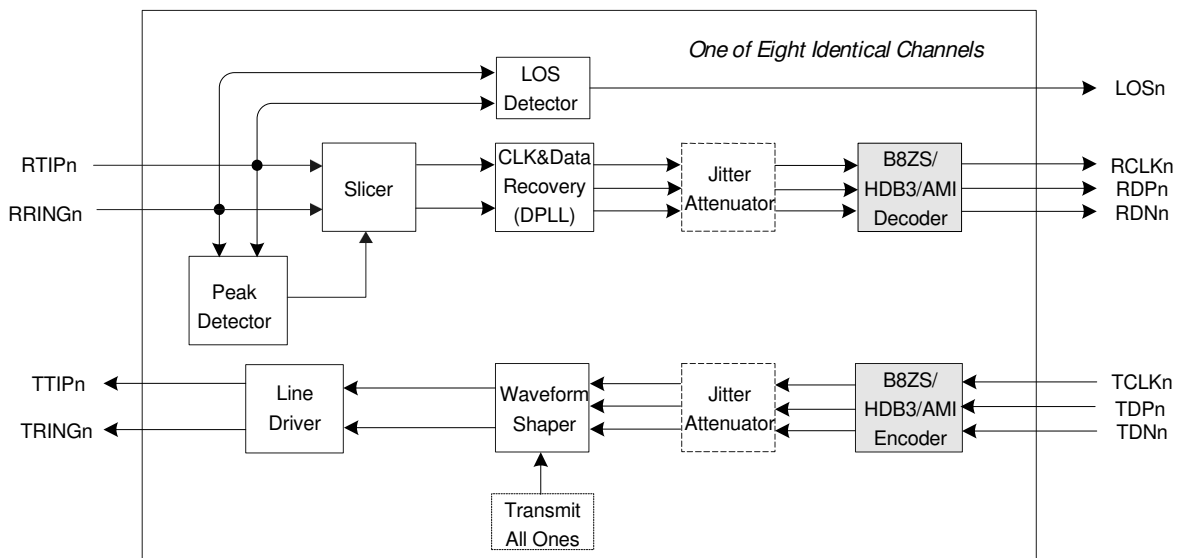

Note: The grey blocks are bypassed and the dotted blocks are selectable.

Figure-4 Dual Rail Interface with Clock Recovery

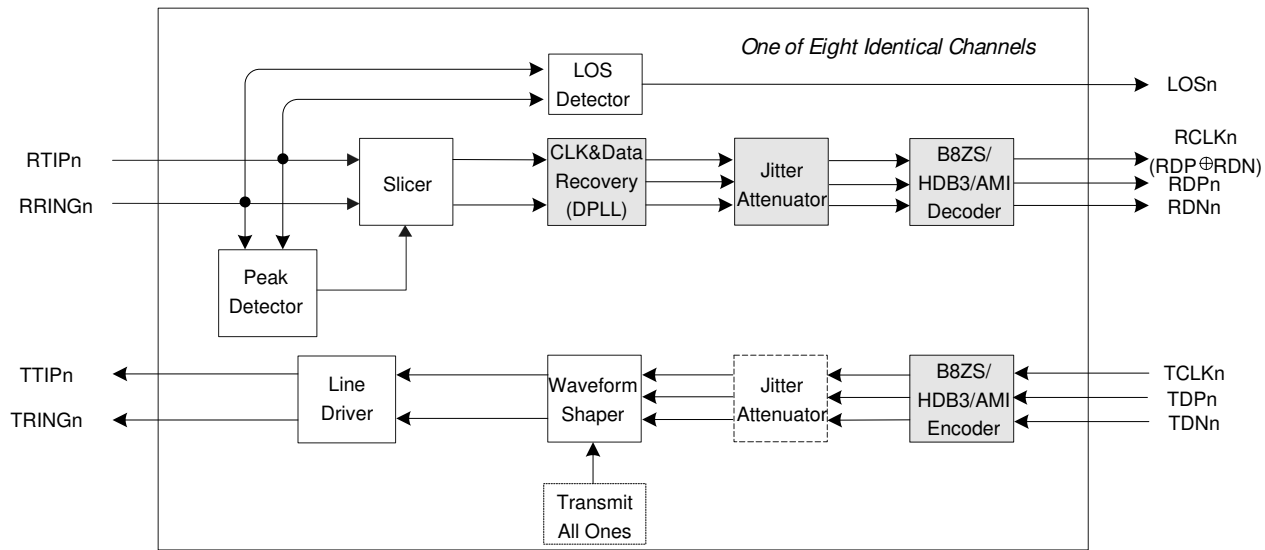

Note: The grey blocks are bypassed and the dotted blocks are selectable.

Figure-5 Dual Rail Interface with Data Recovery

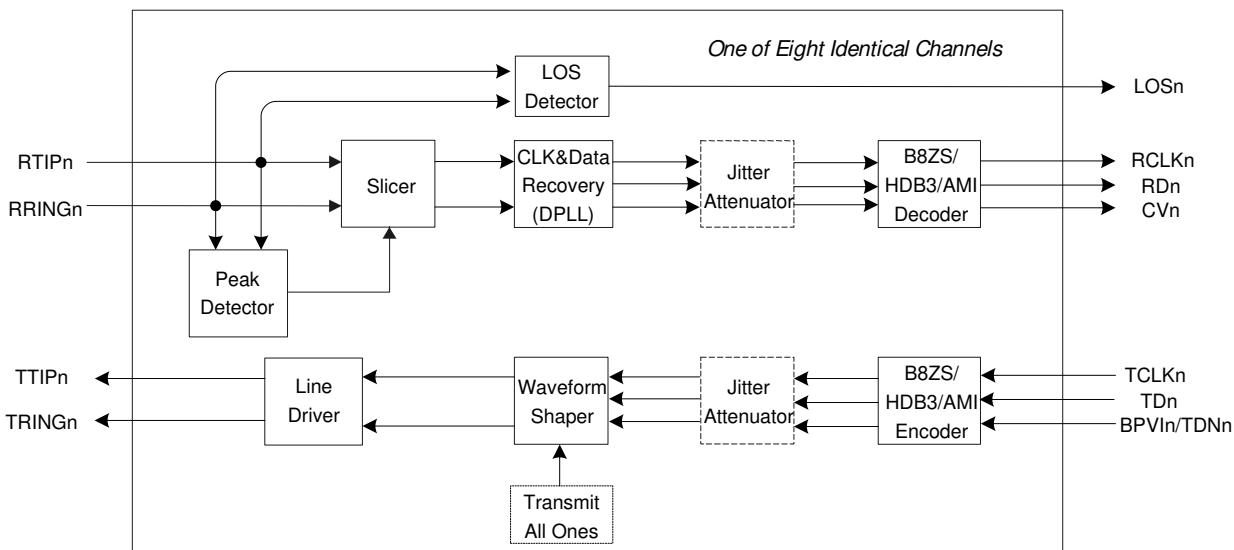

Figure-6 Single Rail Mode

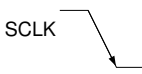

Table-2 System Interface Configuration (In Hardware Mode)

Pin MCLK	Pin TDn	Interface
Clocked	High (≥ 16 MCLK)	Single Rail Mode 1
Clocked	Pulse	Dual Rail mode with Clock Recovery
High	Pulse	Dual Rail mode with Data Recovery. Receive just slices the incoming data. Transmit is determined by the status of TCLKn.
Low	Pulse	Receiver is powered down. Transmit is determined by the status of TCLKn.

Table-3 System Interface Configuration (In Host Mode)

Pin MCLK	Pin TDNn	CRSn in e-CRS	SINGn in e-SING	Interface
Clocked	High	0	0	Single Rail Mode 1
Clocked	Pulse	0	1	Single Rail Mode 2
Clocked	Pulse	0	0	Dual Rail mode with Clock Recovery
Clocked	Pulse	1	0	Dual Rail mode with Data Recovery. Receive just slices the incoming data. Transmit is determined by the status of TCLKn.
High	Pulse	-	-	Dual Rail mode with Data Recovery. Receive just slices the incoming data. Transmit is determined by the status of TCLKn.
Low	Pulse	-	-	Receiver is powered down. Transmit is determined by the status of TCLKn.

Table-4 Active Clock Edge and Active Level

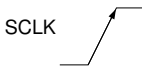
Pin CLKE	Pin RDn/RDPn and CVn/RDNn			Pin SDO	
	Clock Recovery		Slicer Output		
High		Active High	Active High		Active High
Low		Active High	Active Low		Active High

2.3 CLOCK EDGES

The active edge of RCLKn and SCLK are selectable. If pin CLKE is high, the active edge of RCLKn is the rising edge, as for SCLK, that is falling edge. On the contrary, if CLKE is low, the active edge of RCLK is the falling edge and that of SCLK is rising edge. Pins RDn/RDPn, CVn/RDNn and SDO are always active high, and those output signals are clocked out on the active edge of RCLKn and SCLK respectively. See [Table-4 Active Clock Edge and Active Level on page 14](#) for details. However, in dual rail mode without clock recovery, pin CLKE is used to set the active level for RDPn/RDNn raw slicing output: High for active high polarity and low for active low. It should be noted that data on pin SDI are always active high and are sampled on the rising edges of SCLK. The data on pin TDn/TDPn or BPVn/TDNn are also always active high but are sampled on the falling edges of TCLKn, despite the level on CLKE.

2.4 RECEIVER

In receive path, the line signals couple into RRINGn and RTIPn via a transformer and are converted into RZ digital pulses by a data slicer. Adaptation for attenuation is achieved using an integral peak detector that sets the slicing levels. Clock and data are recovered from the received RZ digital pulses by a digital phase-locked loop that provides jitter accommodation. After passing through the selectable jitter attenuator, the recovered data are decoded using B8ZS/HDB3 or AMI line code rules and clocked out of pin RDn in single rail mode, or presented on RDPn/RDNn in an undecoded dual rail NRZ format. Loss of signal, alarm indication signal, line code violation and excessive zeros are detected. The presence of programmable inband loopback codes are also detected. These various changes in status may be enabled to generate interrupts.

2.4.1 PEAK DETECTOR AND SLICER

The slicer determines the presence and polarity of the received pulses. In data recovery mode, the raw positive slicer output appears on RDPn while the negative slicer output appears on RDNn. In clock and data recovery mode, the slicer output is sent to Clock and Data Recovery circuit for abstracting retimed data and optional decoding. The slicer circuit has a built-in peak detector from which the slicing threshold is derived. The slicing threshold is default to 50% (typical) of the peak value.

Signals with an attenuation of up to 12 dB (from 2.4 V) can be recovered by the receiver. To provide immunity from impulsive noise, the peak detectors are held above a minimum level of 0.150 V typically, despite the received signal level.

2.4.2 CLOCK AND DATA RECOVERY

The Clock and Data Recovery is accomplished by Digital Phase Locked Loop (DPLL). The DPLL is clocked 16 times of the received clock rate, i.e. 24.704 MHz in T1 mode or 32.768 MHz in E1 mode. The recovered data and clock from DPLL is then sent to the selectable Jitter Attenuator or decoder for further processing.

The clock recovery and data recovery mode can be selected on a per channel basis by setting bit CRSn in register e-CRS. When bit CRSn is defaulted to '0', the corresponding channel operates in data and clock recovery mode. The recovered clock is output on pin RCLKn and retimed NRZ data are output on pin RDPn/RDNn in dual rail mode or on RDn in single rail mode. When bit CRSn is set to '1', dual rail mode with data recovery is enabled in the corresponding channel and the clock recovery is bypassed. In this condition, the analog line signals are converted to RZ digital bit streams on the RDPn/RDNn pins and internally connected to an EXOR which is fed to the RCLKn output for external clock recovery applications.

If MCLK is pulled high, all the receivers will enter the dual rail mode with data recovery. In this case, register e-CRS is ignored.

2.4.3 B8ZS/HDB3/AMI LINE CODE RULE

Selectable B8ZS/HDB3 and AMI line coding/decoding is provided when the device is configured in single rail mode. B8ZS rules for T1 and HDB3 rules for E1 are enabled by setting bit CODE in register GCF to '0' or pulling pin CODE low. AMI rule is enabled by setting bit CODE in register GCF to '1' or pulling pin CODE high. The settings affect all eight channels.

Individual line code rule selection for each channel, if needed, is available by setting bit SINGn in register e-SING to '1' (to activate bit CODEn in register e-CODE) and programming bit CODEn to select line code rules in the corresponding channel: '0' for B8ZS/HDB3, while '1' for AMI. In this case, the value in bit CODE in register GCF or pin CODE for global control is unaffected in the corresponding channel and only affect in other channels.

In dual rail mode, the decoder/encoder are bypassed. Bit CODE in register GCF, bit CODEn in register e-CODE and pin CODE are ignored.

The configuration of the line code rule is summarized in [Table-5](#).

2.4.4 LOSS OF SIGNAL (LOS) DETECTION

The Loss of Signal Detector monitors the amplitude and density of the received signal on receiver line before the transformer (measured on port A, B shown in [Figure-14](#)). The loss condition is reported by pulling pin LOSn high. At the same time, LOS alarm registers track LOS condition. When LOS is detected or cleared, an interrupt will generate if not masked. In host mode, the detection supports the ANSI T1.231 for T1 mode, ITU G.775 and ETSI 300 233 for E1 mode. In hardware mode, it supports the ITU G.775 and ANSI T1.231.

[Table-6](#) summarizes the conditions of LOS in clock recovery mode.

During LOS, the RDPn/RDNn continue to output the sliced data when bit AISE in register GCF is set to '0' or output all ones as AIS (alarm indication signal) when bit AISE is set to '1'. The RCLKn is replaced by MCLK only if the bit AISE is set.

Table-5 Configuration of the Line Code Rule

Hardware Mode	
CODE	Line Code Rule
Low	All channels in B8ZS/HDB3
High	All channels in AMI

Host Mode			
CODE in GCF	CODEn in e-CODE	SINGn in e-SING	Line Code Rule
0	0/1	0	All channels in B8ZS/HDB3
0	0	1	
1	0/1	0	All channels in AMI
1	1	1	
0	1	1	CHn in AMI
1	0	1	CHn in B8ZS/HDB3

Table-6 LOS Condition in Clock Recovery Mode

		Standard			Signal on LOSn
		ANSI T1.231 for T1	G.775 for E1	ETSI 300 233 for E1	
LOS Detected	Continuous Intervals	175	32	2048 (1 ms)	High
	Amplitude ⁽¹⁾	below typical 200 mVp	below typical 200 mVp	below typical 200 mVp	
LOS Cleared	Density	12.5% (16 marks in a sliding 128-bit period) with no more than 99 continuous zeros	12.5% (4 marks in a sliding 32-bit period) with no more than 15 continuous zeros	12.5% (4 marks in a sliding 32-bit period) with no more than 15 continuous zeros	Low
	Amplitude ⁽¹⁾	exceed typical 250 mVp	exceed typical 250 mVp	exceed typical 250 mVp	

¹. LOS levels at device (RTIPn, RRINGn) with all ones signal. For more detail regarding the LOS parameters, please refer to [Receiver Characteristics on page 49](#).

2.4.5 ALARM INDICATION SIGNAL (AIS) DETECTION

Alarm Indication Signal is available only in host mode with clock recovery, as shown in [Table-7](#).

excessive zeros and code violation are reported respectively. When the device is configured in AMI decoding mode, only bipolar violation can be reported.

2.4.6 ERROR DETECTION

The device can detect excessive zeros, bipolar violation and B8ZS/HDB3 code violation, as shown in [Figure-7](#), [Figure-8](#) and [Figure-9](#). In host mode, the e-CZER and e-CODV are used to determine whether

The error detection is available only in single rail mode in which the pin CVn/RDNn is used as error report output (CVn pin).

The configuration and report status of error detection are summarized in [Table-8](#).

Table-7 AIS Condition

	ITU G.775 for E1 (Register LAC defaulted to '0')	ETSI 300 233 for E1 (Register LAC set to '1')	ANSI T1.231 for T1
AIS Detected	Less than 3 zeros contained in each of two consecutive 512-bit stream are received	Less than 3 zeros contained in a 512-bit stream are received	Less than 9 zeros contained in a 8192-bit stream (a ones density of 99.9% over a period of 5.3 ms) are received
AIS Cleared	3 or more zeros contained in each of two consecutive 512-bit stream are received	3 or more zeros contained in a 512-bit stream are received	9 or more zeros contained in a 8192-bit stream are received

Table-8 Error Detection

Hardware Mode		Host Mode			
Line Code	Pin CVn Reports	Line Code	CODVn in e-CODV	CZERn in e-CZER	Pin CVn Reports
AMI	Bipolar Violation	AMI	-	-	Bipolar Violation
B8ZS/ HDB3	Bipolar Violation + Code Violation	B8ZS/HDB3	0	0	Bipolar Violation + Code Violation
			0	1	Bipolar Violation + Code Violation + Excessive Zeros
			1	0	Bipolar Violation
			1	1	Bipolar Violation + Excessive Zeros

2.4.6.1 BPV DETECTION AND REPORTING IN AMI LINE CODING

AMI stands for Alternative Mark Inversion. It uses bipolar pulses to represent logical values. A logic 0 is represented by no symbol and a logic 1 by pulses of alternating polarity. In AMI line coding, marks

(pulses) are transmitted or received alternatively on tip and ring. If a mark (pulse) is transmitted or received in the same polarity as the prior mark (pulse), it is a bipolar violation.

Bipolar violation (BPV) is a non-zero signal element in an AMI signal that has the same polarity as the previous non-zero signal element.

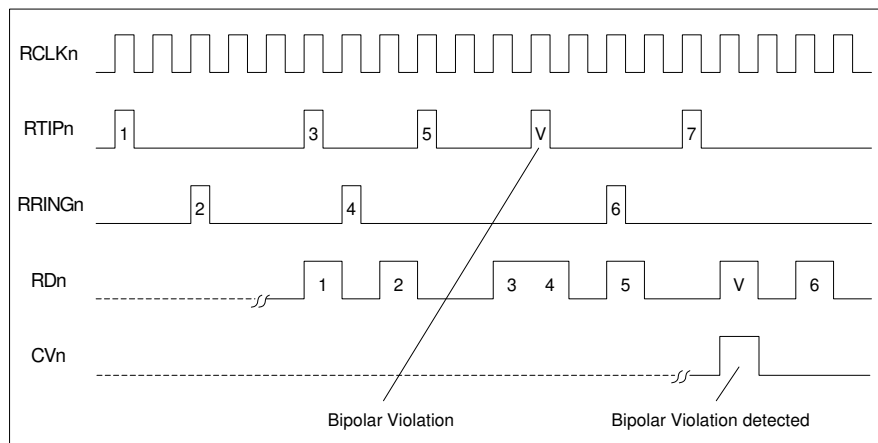

Figure-7 AMI Bipolar Violation

2.4.6.2 EXZ AND BPV DETECTION IN HDB3

The purpose of HDB3 is to prevent transmission of more than 3 consecutive zeros while maintaining DC balance. HDB3 encoder will encode any 4 consecutive zeros as 000V or B00V where V is a bipolar violation and B is a balancing pulse that is opposite in polarity to the previous V. If there is an odd number of B pulses since the last V, then the four consecutive zeros will be substituted as 000V. If there is an even number of B pulses since the last V, then B00V substitution is chosen. The HDB3 decoder, once receiving correctly encoded 000V or B00V, will automatically restore the pattern back into 4 consecutive zeros.

HDB3 decoder will report an EXZ (excessive zero) when it receives 4 consecutive zeros.

The detection of code violation in 000V, coded for 4 consecutive zeros in HDB3 line coding, depends on the number of alternate ones between two consecutive 'V' (code violation) in the input data pattern. If the number of alternate ones between two consecutive violations is an odd number, no violation detection is reported. In Figure-8 input pattern, there is one code violation detection for two 000V patterns. It can be inferred that in Figure-8, there is another code violation prior to the first 000V pattern, and the number of alternate pulses between these two violations is an odd number.

Conversely, if the number of alternate pulses between two violations is an even number, there is a code violation reported for 000V as in Figure-9.

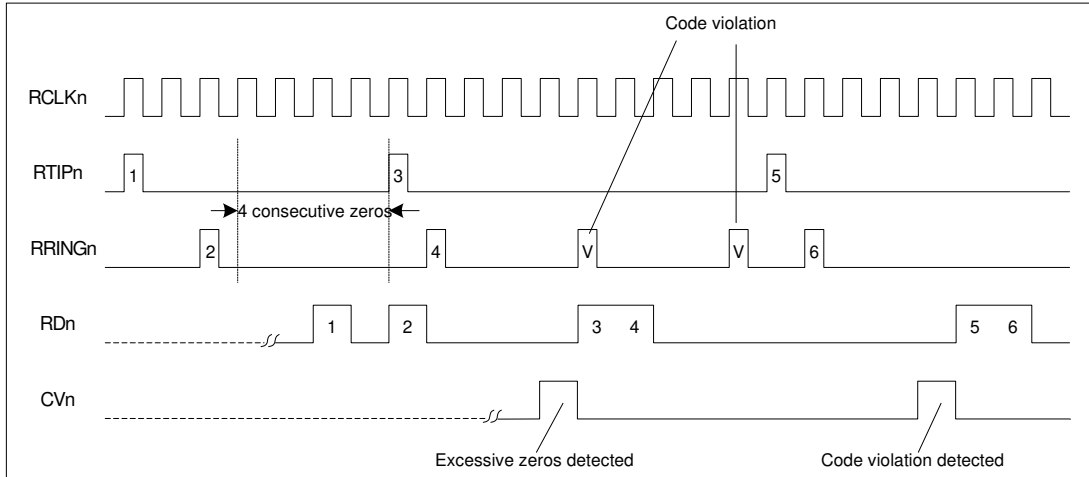

Figure-8 HDB3 Code Violation & Excessive Zeros

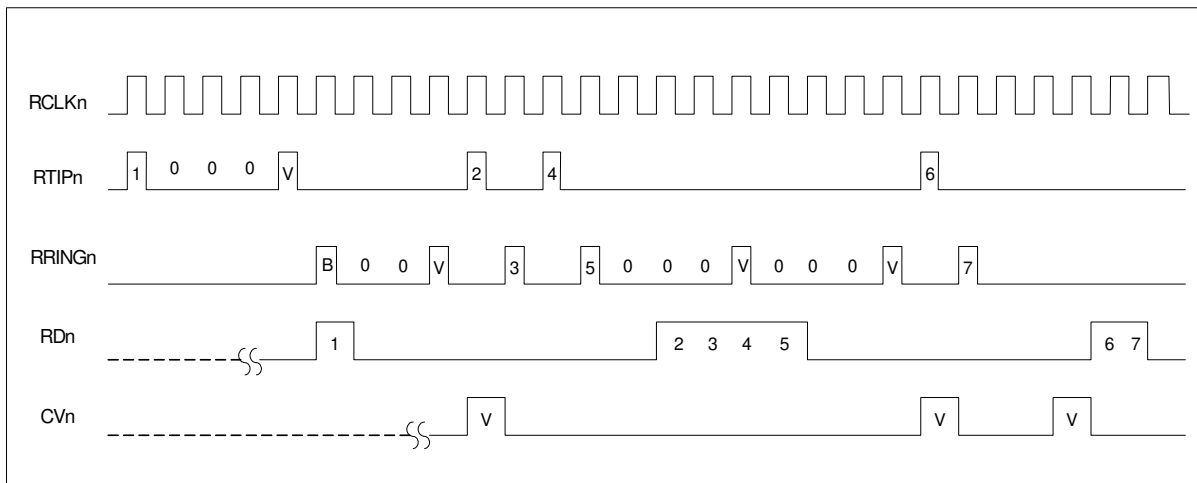

Figure-9 HDB3 Code Violations & Two BPV Detections

2.4.6.3 EXZ AND BPV DETECTION IN B8ZS

B8ZS (Binary 8 Zero Substitution) is an AMI line code with the substitution of a unique code to replace occurrences of eight consecutive zero signal elements. Each block of eight successive zeros is replaced by 000VB0VB, where B represents an inserted non-zero signal element, and V represents an inserted non-zero signal element that is a bipolar violation.

Bipolar violation (BPV) is a non-zero signal element that has the same polarity as the previous non-zero signal element. In normal B8ZS line coding for 8 contiguous zeros, two BPV signals are deliberately inserted. BPV in this case is not an error. Therefore, data and error

pulses will not appear on RDn and CVn pins in this BPV case. Sometimes, a BPV occurs as a result of transmission line noise or interference. As such, it is an error and should be detected and reported.

An excessive zeros (EXZ) for a B8ZS-coded signal is the occurrence of any zero-string length greater than seven contiguous zeros.

As shown in [Figure-11](#), all three bipolar violations (pulse '2', '4' and '5') in the input data pattern are treated as individual code violations: they are recovered as data bits in RD signal line and a BPV is detected for each of the three violated pulses.

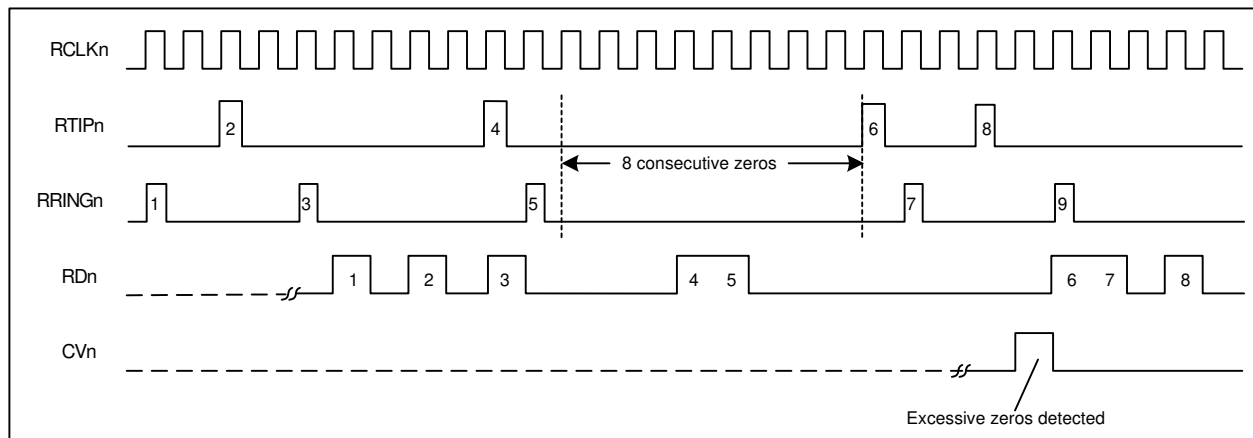

Figure-10 B8ZS Excessive Zeros

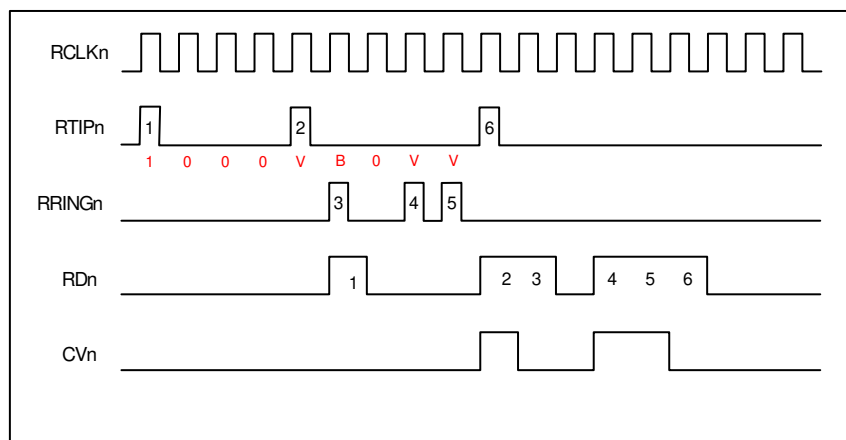

Figure-11 B8ZS Bipolar Violation

2.5 TRANSMITTER

In transmit path, data in NRZ format are clocked into the device on TDn and encoded by AMI or B8ZS/HDB3 line code rules when single rail mode is configured or pre-encoded data in NRZ format are input on TDPn and TDNn when dual rail mode is configured. The data are sampled into the device on falling edges of TCLKn. Jitter attenuator, if enabled, is provided with a FIFO through which the data to be transmitted are passing. A low jitter clock is generated by an integral digital phase-locked loop and is used to read data from the FIFO. The shape of the pulses are user programmable to ensure that the T1/E1 pulse template is met after the signal passes through different cable lengths or types. Bipolar violation, for diagnosis, can be inserted on pin BPVIn if AMI line code rule is enabled.

2.5.1 WAVEFORM SHAPER

T1 pulse template, specified in the DSX-1 Cross-Connect by ANSI T1.102, is illustrated in Figure-12. The device has built-in transmit waveform templates, corresponding to 5 levels of pre-equalization for cable of a length from 0 to 655 ft with each increment of 133 ft.

E1 pulse template, specified in ITU-T G.703, is shown in Figure-13. The device has built-in transmit waveform templates for cable of 75 Ω or 120 Ω.

Any one of the six built-in waveforms can be chosen in both hardware mode and host mode. In hardware mode, setting pins TS[2:0] can select the required waveform template for all the transmitters, as shown in Table-9. In host mode, the waveform template can be configured on a per-channel basis. Bits TSIA[2:0] in register TSIA are used to select the channel and bits TS[2:0] in register TS are used to select the required waveform template.

The built-in waveform shaper uses an internal high frequency clock which is 16XMCLK as the clock reference. This function will be bypassed when MCLK is unavailable.

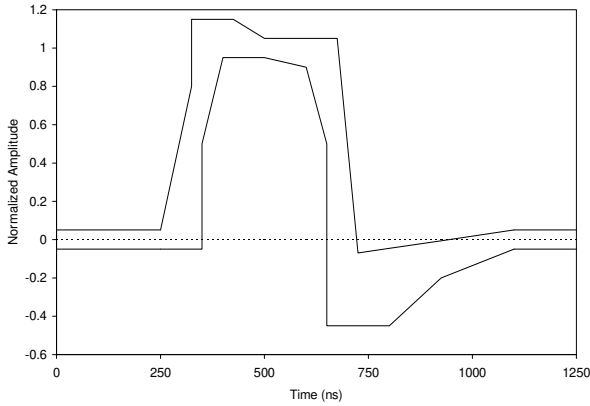

Figure-12 DSX-1 Waveform Template

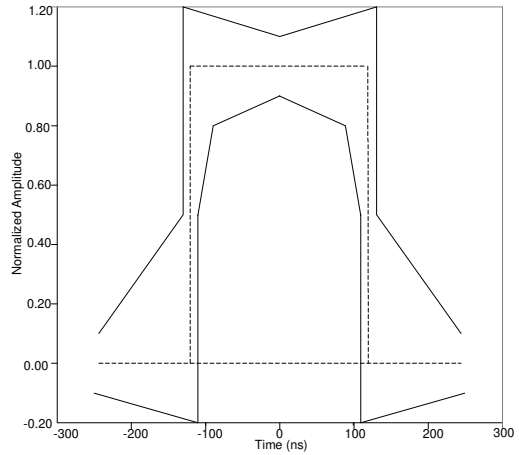

Figure-13 CEPT Waveform Template

Table-9 Built-in Waveform Template Selection

TS2	TS1	TS0	Service	Clock Rate	Cable Length	Maximum Cable Loss (dB) ⁽¹⁾	
0	0	0	E1	2.048 MHz	120 Ω/75 Ω Cable	-	
0	0	1	Reserved				-
0	1	0	Reserved				-
0	1	1	T1	1.544 MHz	0-133 ft. ABAM	0.6	
1	0	0			133-266 ft. ABAM	1.2	
1	0	1			266-399 ft. ABAM	1.8	
1	1	0			399-533 ft. ABAM	2.4	
1	1	1			533-655 ft. ABAM	3.0	

¹ Maximum cable loss at 772 kHz.

2.5.2 BIPOLAR VIOLATION INSERTION

When configured in Single Rail Mode 2 with AMI line code enabled, pin TDNn/BPVn is used as BPVI input. A low-to-high transition on this pin inserts a bipolar violation on the next available mark in the transmit data stream. Sampling occurs on the falling edges of TCLK. But in TAOS (Transmit All Ones) with Analog Loopback, Remote Loopback and Inband Loopback, the BPVI is disabled. In TAOS with Digital Loopback, the BPVI is looped back to the system side, so the data to be transmitted on TTIPn and TRINGn are all ones with no bipolar violation.

2.6 JITTER ATTENUATOR

The jitter attenuator can be selected to work either in transmit path or in receive path or not used. The selection is accomplished by setting pin JAS in hardware mode or configuring bits JACF[1:0] in register GCF in host mode, which affects all eight channels.

For applications which require line synchronization, the line clock needed to be extracted for the internal synchronization, the jitter attenuator is set in the receive path. Another use of the jitter attenuator is to provide clock smoothing in the transmit path for applications such as synchronous/asynchronous demultiplexing applications. In these applications, TCLK will have an instantaneous frequency that is higher than the nominal T1/E1 data rate and in order to set the average long-term TCLK frequency within the transmit line rate specifications, periods of TCLK are suppressed (gapped).

The jitter attenuator integrates a FIFO which can accommodate a gapped TCLK. In host mode, the FIFO length can be 32 X 2 or 64 X 2 bits by programming bit JADP in GCF. In hardware mode, it is fixed to 64 X 2 bits. The FIFO length determines the maximum permissible gap width (see Table-10 Gap Width Limitation). Exceeding these values will cause FIFO overflow or underflow. The data is 16 or 32 bits' delay through the jitter attenuator in the corresponding transmit or receive path. The constant delay feature is crucial for the applications requiring "hitless" switching.

Table-10 Gap Width Limitation

FIFO Length	Max. Gap Width
64 bit	56 UI
32 bit	28 UI

In host mode, bit JABW in GCF determines the jitter attenuator 3 dB corner frequency (fc) for both T1 and E1. In hardware mode, the fc is fixed to 2.5 Hz for T1 or 1.7 Hz for E1. Generally, the lower the fc is, the higher the attenuation. However, lower fc comes at the expense of increased acquisition time. Therefore, the optimum fc is to optimize both the attenuation and the acquisition time. In addition, the longer FIFO length results in an increased throughput delay and also influences the 3 dB corner frequency. Generally, it's recommended to use the lower corner frequency and the shortest FIFO length that can still meet jitter attenuation requirements.

Table-11 Output Jitter Specification

T1	E1
AT&T Pub 62411	ITU-T G.736
GR-253-CODE	ITU-T G.742
TR-TSY-000009	ITU-T G.783
	ETSI CTR 12/13

2.7 LINE INTERFACE CIRCUITRY

The transmit and receive interface RTIPn/RRINGn and TTIPn/TRINGn connections provide a matched interface to the cable. Figure-14 shows the appropriate external components to connect with the cable for one transmit/receive channel. Table-12 summarizes the component values based on the specific application.

Table-12 External Components Values

Component	E1		T1
	75 Ω Coax	120 Ω Twisted Pair	100 Ω Twisted Pair, VDDT = 5.0 V
R _T	9.5 Ω ± 1%	9.5 Ω ± 1%	9.1 Ω ± 1%
R _R	9.31 Ω ± 1%	15 Ω ± 1%	12.4 Ω ± 1%
C _p	2200 pF		1000 pF
D1 - D4	Nihon Inter Electronics - EP05Q03L, 11EQS03L, EC10QS04, EC10QS03L; Motorola - MBR0540T1		

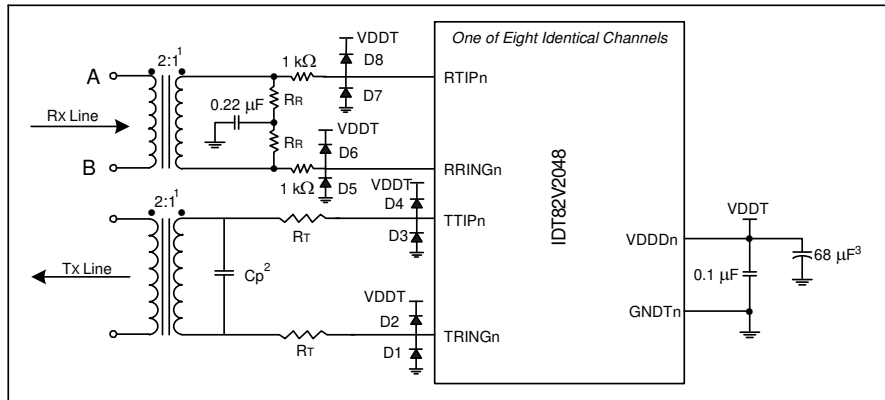

- NOTE:
1. Pulse T1124 transformer is recommended to be used in Standard (STD) operating temperature range (0°C to 70°C), while Pulse T1114 transformer is recommended to be used in Extended (EXT) operating temperature range is -40°C to +85°C. See Transformer Specifications Table for details.
 2. Typical value. Adjust for actual board parasitics to obtain optimum return loss.
 3. Common decoupling capacitor for all VDDT and GNDT pins. One per chip.

Figure-14 External Transmit/Receive Line Circuitry

2.8 TRANSMIT DRIVER POWER SUPPLY

All transmit driver power supplies must be 5.0 V or 3.3 V.

In E1 mode, despite the power supply voltage, the 75 Ω/120 Ω lines are driven through a pair of 9.5 Ω series resistors and a 1:2 transformer.

In T1 mode, only 5.0 V can be selected, 100 lines are driven through a pair of 9.1 Ω series resistors and a 1:2 transformer.

In harsh cable environment, series resistors are required to improve the transmit return loss performance and protect the device from surges coupling into the device.

Table-13 Transformer Specifications⁽¹⁾

Electrical Specification @ 25°C										
Part No.		Turns Ratio (Pri: sec ± 2%)		OCL @ 25°C (mH MIN)		L _L (μH MAX)		C _{www} (pF MAX)		Package/Schematic
STD Temp.	EXT Temp.	Transmit	Receive	Transmit	Receive	Transmit	Receive	Transmit	Receive	
T1124	T1114	1:2CT	1CT:2	1.2	1.2	.6	.6	35	35	TOU/3

¹ Pulse T1124 transformer is recommended to be used in Standard (STD) operating temperature range (0°C to 70°C), while Pulse T1114 transformer is recommended to be used in Extended (EXT) operating temperature range is -40°C to +85°C.

2.9 POWER DRIVER FAILURE MONITOR

An internal power Driver Failure Monitor (DFMON), parallel connected with TTIPn and TRINGn, can detect short circuit failure between TTIPn and TRINGn pins. Bit SCPB in register GCF decides whether the output driver short circuit protection is enabled. When the short circuit protection is enabled, the driver output current is limited to a typical value: 180 mA_p. Also, register DF, DFI and DFM will be available. When DFMON will detect a short circuit, register DF will be set. With a short circuit failure detected and short circuit protection enabled, register DFI will be set and an interrupt will be generated on pin INT.

2.10 TRANSMIT LINE SIDE SHORT CIRCUIT FAILURE DETECTION

In E1 or T1 with 5 V VDDT, a pair of 9.5 Ω serial resistors connect with TTIPn and TRINGn pins and limit the output current. In this case, the output current is a limited value which is always lower than the typical line short circuit current 180 mA_p, even if the transmit line side is shorted.

Refer to [Table-12 External Components Values](#) for details.

2.11 LINE PROTECTION

In transmit side, the Schottky diodes D1~D4 are required to protect the line driver and improve the design robustness. In receive side, the series resistors of 1 kΩ are used to protect the receiver against current surges coupled in the device. The series resistors do not affect the receiver sensitivity, since the receiver impedance is as high as 120 kΩ typically.

2.12 HITLESS PROTECTION SWITCHING (HPS)

The IDT82V2048 transceivers include an output driver with high-Z feature for T1/E1 redundancy applications. This feature reduces the cost of redundancy protection by eliminating external relays. Details of HPS are described in relative Application Note.

2.13 SOFTWARE RESET

Writing register RS will cause software reset by initiating about 1 μs reset cycle. This operation set all the registers to their default value.

2.14 POWER ON RESET

During power up, an internal reset signal sets all the registers to default values. The power-on reset takes at least 10 μs, starting from when the power supply exceeds 2/3 VDDA.

2.15 POWER DOWN

Each transmit channel will be powered down by pulling pin TCLKn low for more than 64 MCLK cycles (if MCLK is available) or about 30 μs (if MCLK is not available). In host mode, each transmit channel will also be powered down by setting bit TPDNn in register e-TPDN to '1'.

All the receivers will be powered down when MCLK is low. When MCLK is clocked or high, setting bit RPDNn in register e-RPDN to '1' will configure the corresponding receiver to be powered down.

2.16 INTERFACE WITH 5 V LOGIC

The IDT82V2048 can interface directly with 5 V TTL family devices. The internal input pads are tolerant to 5 V output from TTL and CMOS family devices.

2.17 LOOPBACK MODE

The device provides five different diagnostic loopback configurations: Digital Loopback, Analog Loopback, Remote Loopback, Dual Loopback and Inband Loopback. In host mode, these functions are implemented by programming the registers DLB, ALB, RLB and Inband Loopback register group respectively. In hardware mode, only Analog Loopback and Remote Loopback can be selected by pin LPn.

2.17.1 DIGITAL LOOPBACK

By programming the bits of register DLB, each channel of the device can be configured in Local Digital Loopback. In this configuration, the data and clock to be transmitted, after passing the encoder, are looped back to Jitter Attenuator (if enabled) and decoder in the receive path, then output on RCLKn, RDn/RDPn and CVn/RDNn. The data to be transmitted are still output on TTIPn and TRINGn while the data received on RTIPn and RRINGn are ignored. The Loss Detector is still in use. [Figure-15](#) shows the process.

During Digital Loopback, the received signal on the receive line is still monitored by the LOS Detector (See [2.4.4 Loss of Signal \(LOS\) Detection](#) for details). In case of a LOS condition and AIS insertion enabled, all ones signal will be output on RDPn/RDNn. With ATAO enabled, all ones signal will be also output on TTIPn/TRINGn. AIS insertion can be enabled by setting AISE bit in register GCF and ATAO can be enabled by setting register ATAO (default disabled).

2.17.2 ANALOG LOOPBACK

By programming the bits of register ALB or pulling pin LPn high, each channel of the device can be configured in Analog Loopback. In this configuration, the data to be transmitted output from the line driver are internally looped back to the slicer and peak detector in the receive path and output on RCLKn, RDn/RDPn and CVn/RDNn. The data to be transmitted are still output on TTIPn and TRINGn while the data received on RTIPn and RRINGn are ignored. The LOS Detector (See [2.4.4 Loss of Signal \(LOS\) Detection](#) for details) is still in use and monitors the internal looped back data. If a LOS condition on TDPn/TDNn is expected during Analog Loopback, ATAO should be disabled (default). [Figure-16](#) shows the process.

The TTIPn and RTIPn, TRINGn and RRINGn cannot be connected directly to do the external analog loopback test. Line impedance loading is required to conduct the external analog loopback test.

2.17.3 REMOTE LOOPBACK

By programming the bits of register RLB or pulling pin LPn low, each channel of the device can be set in Remote Loopback. In this configuration, the data and clock recovered by the clock and data recovery circuits are looped to waveform shaper and output on TTIPn and TRINGn. The jitter attenuator is also included in loopback when enabled in the transmit or receive path. The received data and clock are still output on RCLKn, RDn/RDPn and CVn/RDNn while the data to be transmitted on TCLKn, TDn/TDPn and BPVIn/TDNn are ignored. The LOS Detector is still in use. [Figure-17](#) shows the process.

2.17.4 DUAL LOOPBACK

Dual Loopback mode is set by setting bit DLBn in register DLB and bit RLBn in register RLB to '1'. In this configuration, after passing the encoder, the data and clock to be transmitted are looped back to decoder directly and output on RCLKn, RDn/RDPn and CVn/RDNn. The recovered data from RTIPn and RRINGn are looped back to waveform shaper through JA (if selected) and output on TTIPn and TRINGn. The LOS Detector is still in use. Figure-18 shows the process.

2.17.5 TRANSMIT ALL ONES (TAOS)

In hardware mode, the TAOS mode is set by pulling pin TCLKn high for more than 16 MCLK cycles. In host mode, TAOS mode is set by programming register TAO. In addition, automatic TAOS signals are inserted by setting register ATAO when Loss of Signal occurs. Note that the TAOS generator adopts MCLK as a timing reference. In order to assure that the output frequency is within specified limits, MCLK must have the applicable stability.

The TAOS mode, the TAOS mode with Digital Loopback and the TAOS mode with Analog Loopback are shown in Figure-19, Figure-20 and Figure-21.

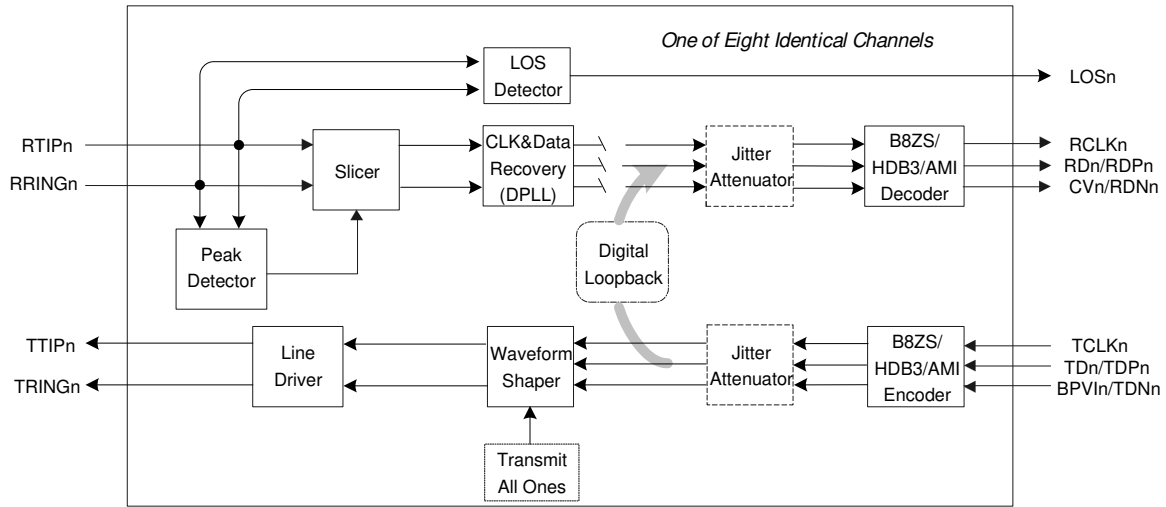

Figure-15 Digital Loopback

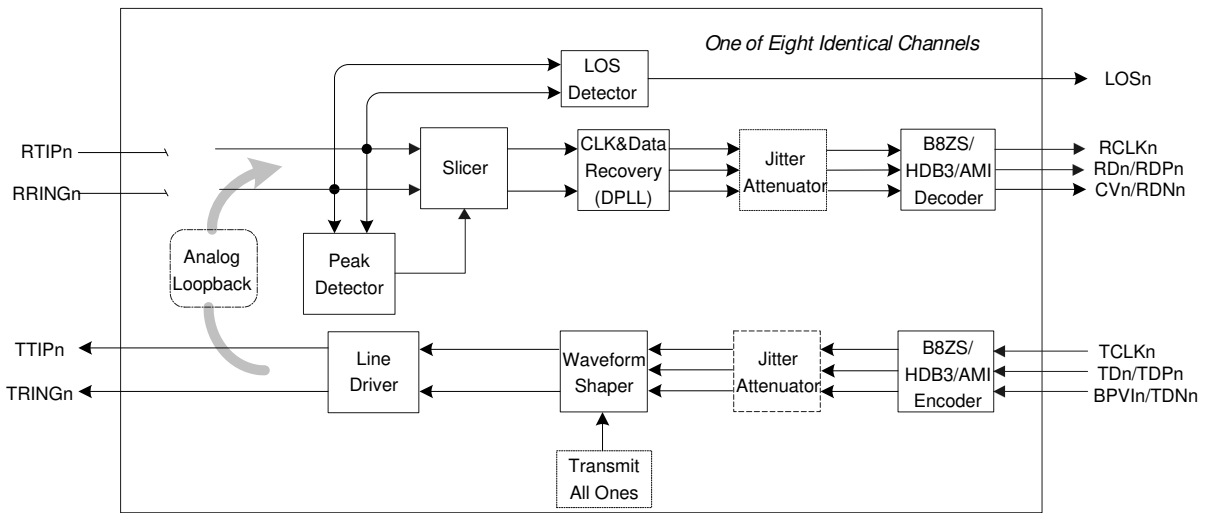

Figure-16 Analog Loopback

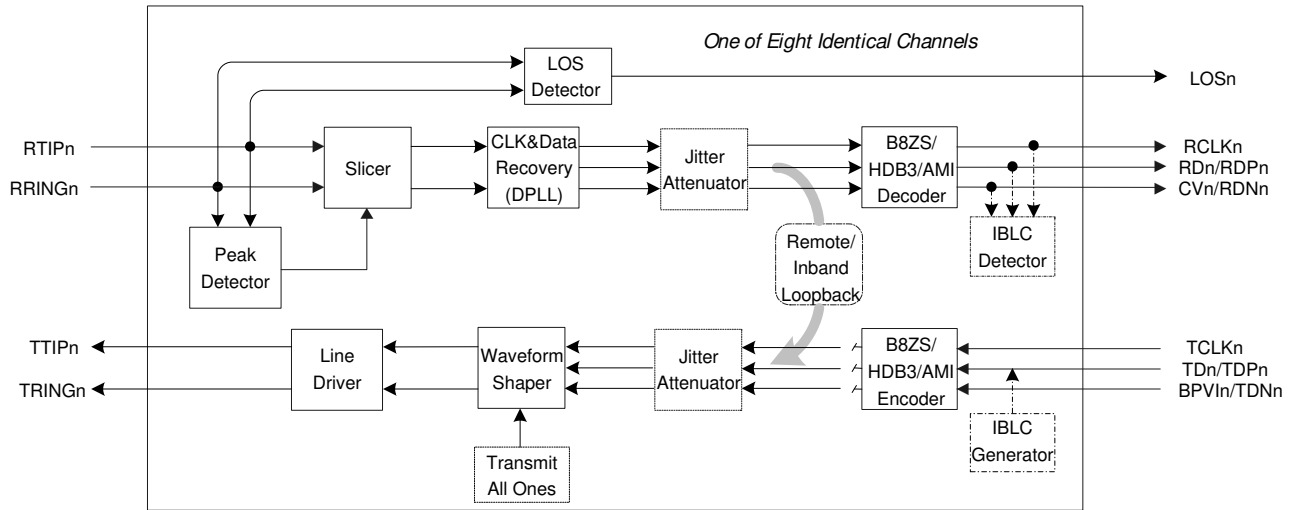

Figure-17 Remote Loopback

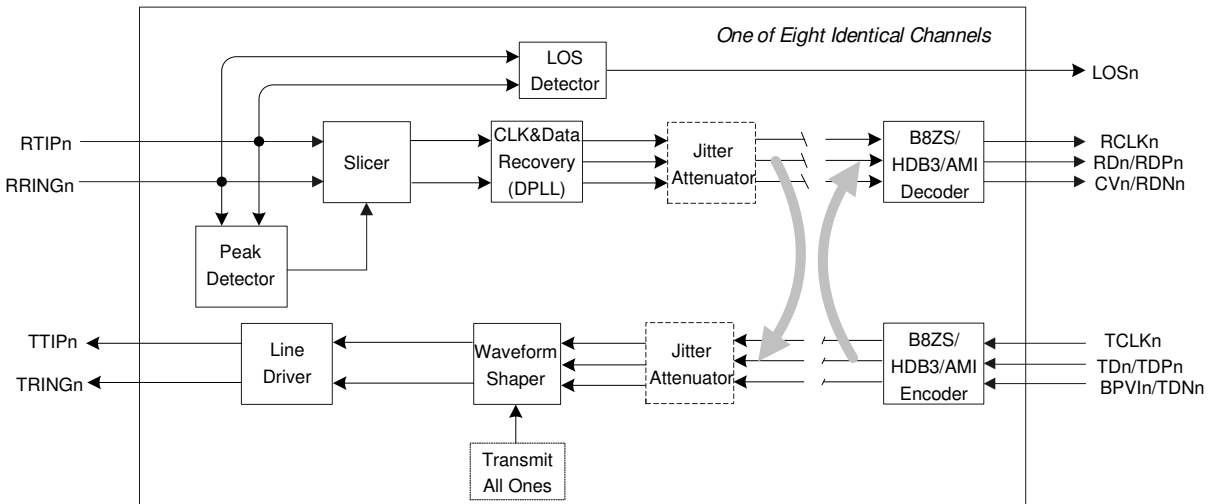

Figure-18 Dual Loopback

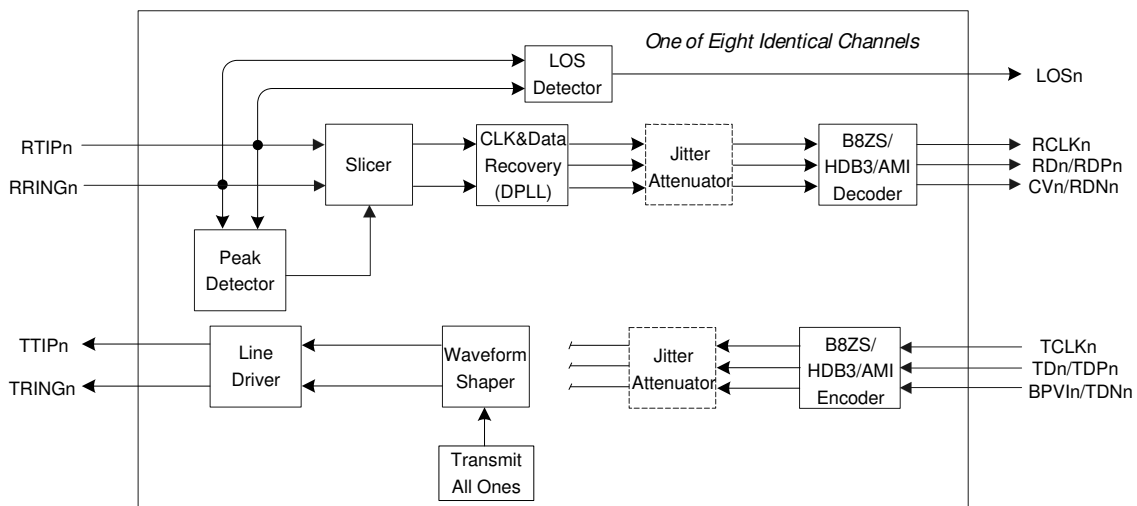

Figure-19 TAOS Data Path

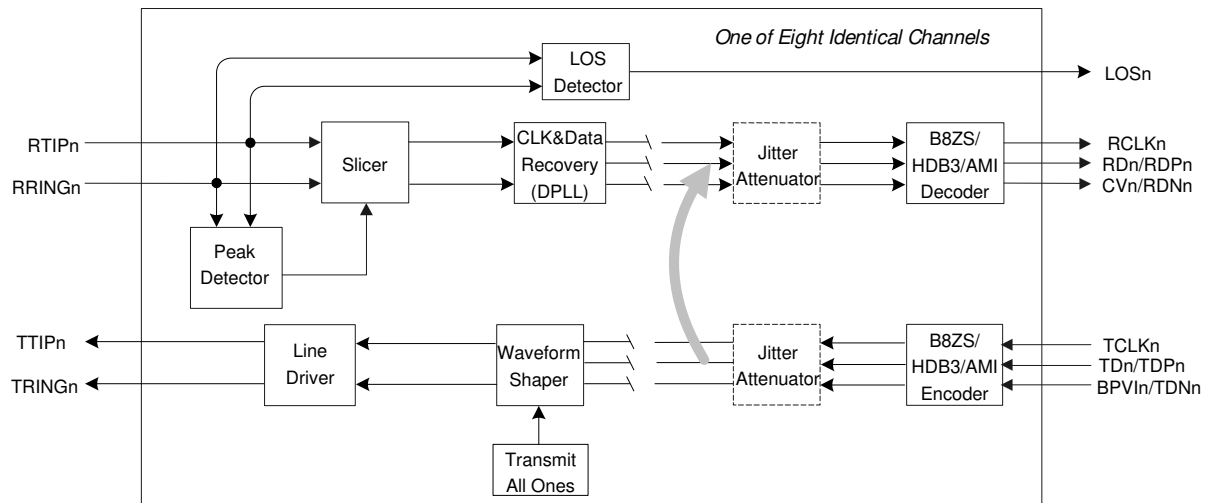

Figure-20 TAOS with Digital Loopback

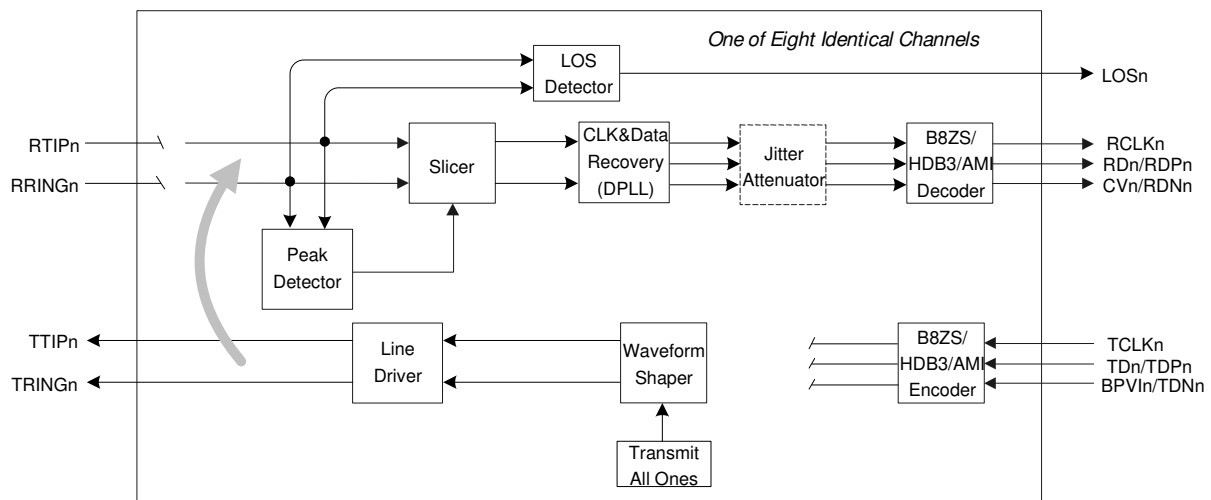

Figure-21 TAOS with Analog Loopback

2.17.6 INBAND LOOPBACK

Inband Loopback is a function that facilitates the system remote diagnosis. When this function is enabled, the chip will detect or generate the Inband Loopback Code. There are two kinds of Inband Loopback Code: Activate Code and Deactivate Code. If the Activate Code is received from the far end in a continuous 5.1 second, the chip will automatically go into Remote Loopback Mode (shown in Figure-17). If the Deactivate Code is received from the far end in a continuous 5.1 second, the chip quits from the Remote Loopback mode. The chip can send the Activate Code and Deactivate Code to the far end. Two function blocks: IBLC Detector (Inband Loopback Code Detector) and IBLC Generator (Inband Loopback Code Generator), realize the Inband Loopback.

The detection of Inband Loopback Code is enabled by bit LBDE in register e-LBCF. If bit ALBE in register e-LBCF is set to '1', the chip will automatically go into or quit from the Remote Loopback mode based on the receipt of Inband Loopback Code. The length of the Activate Code is defined in bits LBAL[1:0] in register e-LBCF; and the length of the Deactivate Code is defined in bits LBDL[1:0] in register e-LBCF. The pattern

of the Activate Code is defined in register e-LBAC, and the pattern of the Deactivate Code is defined in register e-LBDC. The above settings are globally effective for all the eight channels. The presence of Inband Loopback Code in each channel is reflected timely in register e-LBS. Any transition of each bit in register e-LBS will be reflected in register e-LBI, and if enabled in register e-LBM, will generate an interrupt. The required sequence of programming the Inband Loopback Code detection is: First, set registers e-LBAC and e-LBDC, followed by register e-LBM. Finally, to activate Inband Loopback detection, set register e-LBCF.

The Inband Loopback Code Generator use the same registers as the Inband Loopback Detector to define the length and pattern of Activate Code and Deactivate Code. The length and pattern of the generated Activate Code and Deactivate Code can be different from the detected Activate Code and Deactivate Code. Register e-LBGS determines sending Activate Code or Deactivate Code, and register e-LBGE acts as a switch to start or stop the sending of Inband Loopback Code to the selected channels. Before sending Inband Loopback Code, users should be sure that registers e-LBCF, e-LBAC, e-LBDC and e-LBSG

are configured properly. The required sequence for configuring the Inband Loopback Generator is: First, set registers e-LBAC and e-LBDC, followed by register e-LBCF. Then, to select the Inband Loopback generator set registers e-LBGS and then e-LBGE.

The Inband Loopback Detection and the Inband Loopback Generation can not be used simultaneously.

Example: 5-bit Loop-up/Loop-down Detection (w/o interrupts):

(see note in register description for e-LBAC)

Loop-up code: 11000
 Loop-down code: 11100

Set (in this order)

e-LBAC (0x09) = 0xC6 (11000110)
 e-LBDC (0x0A) = 0xE7 (11100111)
 e-LBCF (0x08) = 0x30

Example: 5-bit Loop-up/Loop-down Activation on Channel 1 (w/o interrupts):

Loop-up code: 11000
 Loop-down code: 11100

Set (in this order)

e-LBAC (0x09) = 0xC6 (11000110)

Table-14 Parallel Host Interface Pins

MODE[2:0]	Host Interface	Generic Control, Data and Output Pin
100	Non-multiplexed Motorola interface	\overline{CS} , \overline{ACK} , \overline{DS} , $\overline{R/\overline{W}}$, \overline{AS} , A[4:0], D[7:0], \overline{INT}
101	Non-multiplexed Intel interface	\overline{CS} , RDY, \overline{WR} , \overline{RD} , ALE, A[4:0], D[7:0], \overline{INT}
110	Multiplexed Motorola interface	\overline{CS} , \overline{ACK} , \overline{DS} , $\overline{R/\overline{W}}$, \overline{AS} , AD[7:0], \overline{INT}
111	Multiplexed Intel interface	\overline{CS} , RDY, \overline{WR} , \overline{RD} , ALE, AD[7:0], \overline{INT}

e-LBDC (0x0A) = 0xE7 (11100111)
 e-LBCF (0x08) = 0x00
 e-LBGS (0x0E) = 0x00
 e-LBGE (0x0F) = 0x02

2.18 HOST INTERFACE

The host interface provides access to read and write the registers in the device. The interface consists of serial host interface and parallel host interface. By pulling pin MODE2 to VDDIO/2 or high, the device can be set to work in serial mode and in parallel mode respectively.

2.18.1 PARALLEL HOST INTERFACE

The interface is compatible with Motorola and Intel host. Pins MODE1 and MODE0 are used to select the operating mode of the parallel host interface. When pin MODE1 is pulled low, the host uses separate address bus and data bus. When high, multiplexed address/data bus is used. When pin MODE0 is pulled low, the parallel host interface is configured for Motorola compatible hosts. When pin MODE0 is pulled high, the parallel host interface is configured for Intel compatible hosts. See [Table-1 Pin Description](#) for more details. The host interface pins in each operation mode is tabulated in [Table-14](#):

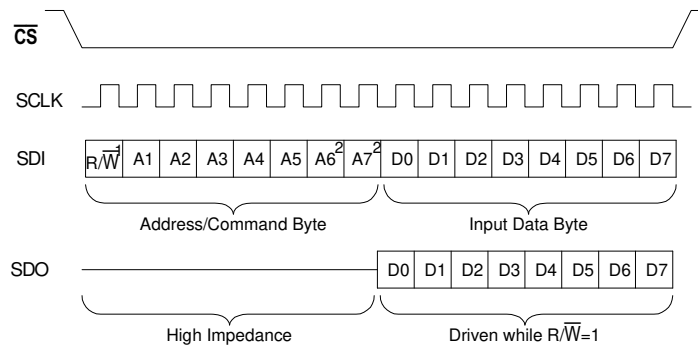

1. While $\overline{R/\overline{W}}=1$, read from IDT82V2048; While $\overline{R/\overline{W}}=0$, write to IDT82V2048.
2. Ignored.

Figure-22 Serial Host Mode Timing

2.18.2 SERIAL HOST INTERFACE

By pulling pin MODE2 to VDDIO/2, the device operates in the serial host Mode. In this mode, the registers are accessible through a 16-bit word which contains an 8-bit command/address byte (bit $\overline{R/\overline{W}}$ and 5-address-bit A1~A5, A6 and A7 bits are ignored) and a subsequent 8-bit

data byte (D7~D0), as shown in [Figure-22](#). When bit $\overline{R/\overline{W}}$ is set to '1', data is read out from pin SDO. When bit $\overline{R/\overline{W}}$ is set to '0', data on pin SDI is written into the register whose address is indicated by address bits A5~A1. See [Figure-22 Serial Host Mode Timing](#).

2.19 INTERRUPT HANDLING

2.19.1 INTERRUPT SOURCES

There are four kinds of interrupt sources:

1. *Status change in register LOS. The analog/digital loss of signal detector continuously monitors the received signal to update the specific bit in register LOS which indicates presence or absence of a LOS condition.*
2. *Status change in register DF. The automatic power driver circuit continuously monitors the output drivers signal to update the specific bit in register DFM which indicates presence or absence of an output driver short circuit condition.*
3. *Status change in register AIS. The AIS detector monitors the received signal to update the specific bit in register AIS which indicates presence or absence of a AIS condition.*
4. *Status change in register e-LBS. The IBLC detector monitors the inband loopback activation or deactivation code in received signal to update the specific bit in register e-LBS which indicates presence or absence of an inband loopback condition.*

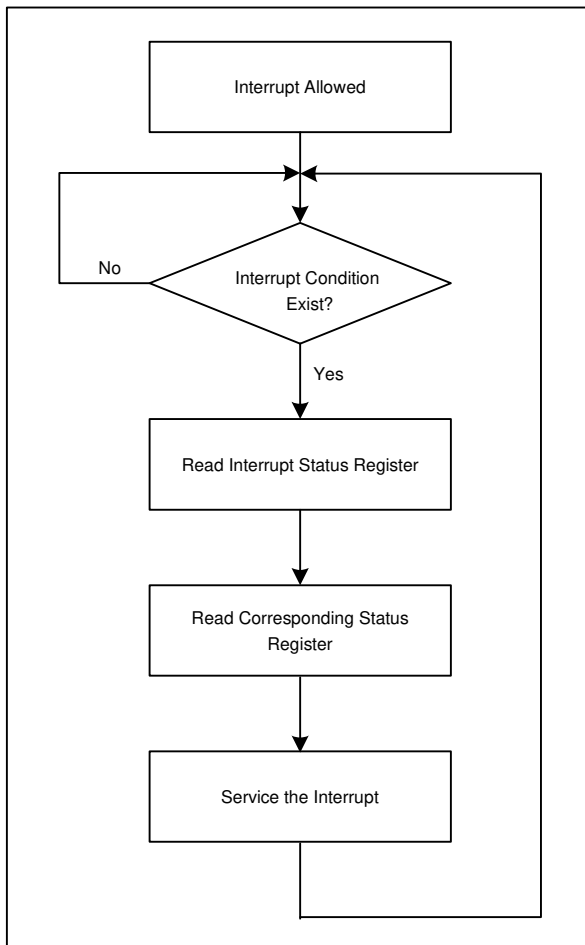

Figure-23 Interrupt Service Routine

2.19.2 INTERRUPT ENABLE

The IDT82V2048 provides a latched interrupt output ($\overline{\text{INT}}$) and the four kinds of interrupts are all reported by this pin. When the Interrupt Mask register (LOSM, DFM, AISM and e-LBM) is set to '1', the Interrupt Status register (LOSI, DFI, AISI and e-LBI) is enabled respectively. Whenever there is a transition ('0' to '1' or '1' to '0') in the corresponding status register, the Interrupt Status register will change into '1', which means an interrupt occurs, and there will be a high to low transition on $\overline{\text{INT}}$ pin. An external pull-up resistor of approximately 10 k Ω is required to support the wire-OR operation of $\overline{\text{INT}}$. When any of the four Interrupt Mask registers is set to '0' (the power-on default value is '0'), the corresponding Interrupt Status register is disabled and the transition on status register is ignored.

2.19.3 INTERRUPT CLEARING

When an interrupt occurs, the Interrupt Status registers: LOSI, DFI, AISI and e-LBI, are read to identify the interrupt source. These registers will be cleared to '0' after the corresponding status registers: LOS, DF, AIS and e-LBS are read. The Status registers will be cleared once the corresponding conditions are met.

Pin $\overline{\text{INT}}$ is pulled high when there is no pending interrupt left. The interrupt handling in the interrupt service routine is showed in [Figure-23](#).

2.20 G.772 MONITORING

The eight channels of IDT82V2048 can all be configured to work as regular transceivers. In applications using only seven channels (channels 1 to 7), channel 0 is configured to non-intrusively monitor any of the other channels' inputs or outputs on the line side. The monitoring is non-intrusive per ITU-T G.772. [Figure-24](#) shows the Monitoring Principle. The receiver path or transmitter path to be monitored is configured by pins MC[3:0] in hardware mode or by register PMON in host mode.

The monitored signal goes through the clock and data recovery circuit of channel 0. The monitored clock can output on RCLK0 which can be used as a timing interfaces derived from E1 signal. The monitored data can be observed digitally at the output pins RCLK0, RD0/RDP0 and RDN0. LOS detector is still in use in channel 0 for the monitored signal.

In monitoring mode, channel 0 can be configured in Remote Loop-back. The signal which is being monitored will output on TTIP0 and TRING0. The output signal can then be connected to a standard test equipment with an E1 electrical interface for non-intrusive monitoring.

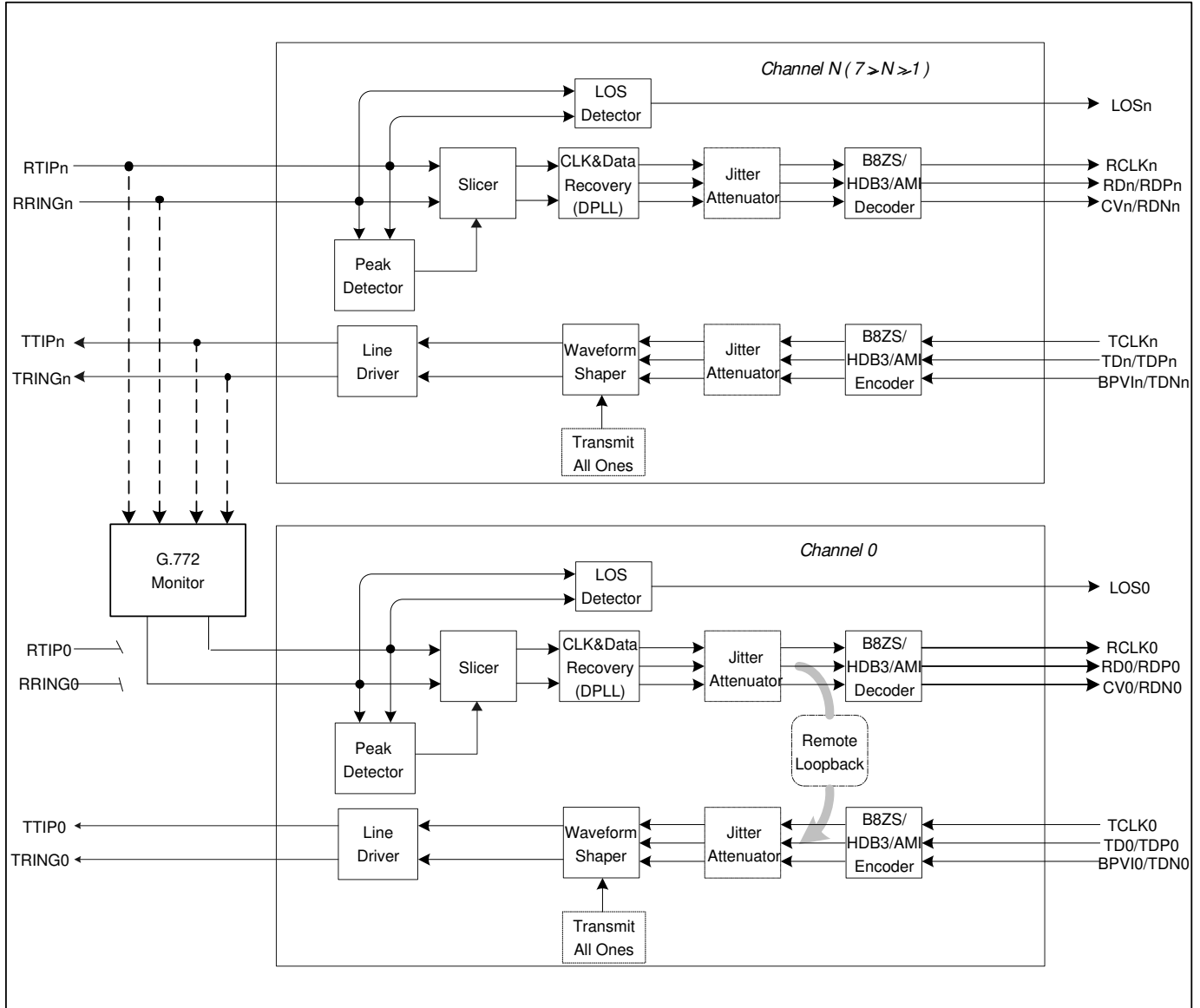

Figure-24 Monitoring Principle

3 PROGRAMMING INFORMATION

3.1 REGISTER LIST AND MAP

There are 23 primary registers (including an Address Pointer Control Register and 16 expanded registers in the device).

Whatever the control interface is, 5 address bits are used to set the registers. In non-multiplexed parallel interface mode, the five dedicated address bits are A[4:0]. In multiplexed parallel interface mode, AD[4:0] carries the address information. In serial interface mode, A[5:1] are used to address the register.

The Register ADDP, addressed as 11111 or 1F Hex, switches between primary registers bank and expanded registers bank.

By setting the register ADDP to 'AAH', the 5 address bits point to the expanded register bank, that is, the expanded registers are available. By clearing register ADDP, the primary registers are available.

Primary Registers, whose addresses are 16H to 1EH, are reserved. Expanded registers, whose addresses are 10H to 1EH, are used for test and must be set to '0' (default).

Table-15 Primary Register List

Address			Register	R/W	Explanation
Hex	Serial Interface A7-A1	Parallel Interface A7-A0			
00	XX00000	XXX00000	ID	R	Device ID Register
01	XX00001	XXX00001	ALB	R/W	Analog Loopback Configuration Register
02	XX00010	XXX00010	RLB	R/W	Remote Loopback Configuration Register
03	XX00011	XXX00011	TAO	R/W	Transmit All Ones Configuration Register
04	XX00100	XXX00100	LOS	R	Loss of Signal Status Register
05	XX00101	XXX00101	DF	R	Driver Fault Status Register
06	XX00110	XXX00110	LOSM	R/W	LOS Interrupt Mask Register
07	XX00111	XXX00111	DFM	R/W	Driver Fault Interrupt Mask Register
08	XX01000	XXX01000	LOSI	R	LOS Interrupt Status Register
09	XX01001	XXX01001	DFI	R	Driver Fault Interrupt Status Register
0A	XX01010	XXX01010	RS	W	Software Reset Register
0B	XX01011	XXX01011	PMON	R/W	Performance Monitor Configuration Register
0C	XX01100	XXX01100	DLB	R/W	Digital Loopback Configuration Register
0D	XX01101	XXX01101	LAC	R/W	LOS/AIS Criteria Configuration Register
0E	XX01110	XXX01110	ATAO	R/W	Automatic TAOS Configuration Register
0F	XX01111	XXX01111	GCF	R/W	Global Configuration Register
10	XX10000	XXX10000	TSIA	R/W	Indirect Address Register for Transmit Template Select
11	XX10001	XXX10001	TS	R/W	Transmit Template Select Register
12	XX10010	XXX10010	OE	R/W	Output Enable Configuration Register
13	XX10011	XXX10011	AIS	R	AIS Status Register
14	XX10100	XXX10100	AISM	R/W	AIS Interrupt Mask Register
15	XX10101	XXX10101	AISI	R	AIS Interrupt Status Register
16	XX10110	XXX10110			Reserved
17	XX10111	XXX10111			
18	XX11000	XXX11000			
19	XX11001	XXX11001			
1A	XX11010	XXX11010			
1B	XX11011	XXX11011			
1C	XX11100	XXX11100			
1D	XX11101	XXX11101			
1E	XX11110	XXX11110			
1F	XX11111	XXX11111	ADDP	R/W	

Table-16 Expanded (Indirect Address Mode) Register List

Address			Register	R/W	Explanation
Hex	Serial Interface A7-A1	Parallel Interface A7-A0			
00	XX00000	XXX00000	e-SING	R/W	Single Rail Mode Setting Register
01	XX00001	XXX00001	e-CODE	R/W	Encoder/Decoder Selection Register
02	XX00010	XXX00010	e-CRS	R/W	Clock Recovery Enable/Disable Register
03	XX00011	XXX00011	e-RPDN	R/W	Receiver n Powerdown Enable/Disable Register
04	XX00100	XXX00100	e-TPDN	R/W	Transmitter n Powerdown Enable/Disable Register
05	XX00101	XXX00101	e-CZER	R/W	Consecutive Zero Detect Enable/Disable Register
06	XX00110	XXX00110	e-CODV	R/W	Code Violation Detect Enable/Disable Register
07	XX00111	XXX00111	e-EQUA	R/W	Enable Equalizer Enable/Disable Register
08	XX01000	XXX01000	e-LBCF	R/W	Inband Loopback Configuration Register
09	XX01001	XXX01001	e-LBAC	R/W	Inband Loopback Activation Code Register
0A	XX01010	XXX01010	e-LBDC	R/W	Inband Loopback Deactivation Code Register
0B	XX01011	XXX01011	e-LBS	R	Inband Loopback Code Receive Status Register
0C	XX01100	XXX01100	e-LBM	R/W	Inband Loopback Interrupt Mask Register
0D	XX01101	XXX01101	e-LBI	R	Inband Loopback Interrupt Status Register
0E	XX01110	XXX01110	e-LBGS	R/W	Inband Loopback Activate/Deactivate Code Generator Selection Register
0F	XX01111	XXX01111	e-LBGE	R/W	Inband Loopback Activate/Deactivate Code Generator Enable Register
10	XX10000	XXX10000			Test
11	XX10001	XXX10001			
12	XX10010	XXX10010			
13	XX10011	XXX10011			
14	XX10100	XXX10100			
15	XX10101	XXX10101			
16	XX10110	XXX10110			
17	XX10111	XXX10111			
18	XX11000	XXX11000			
19	XX11001	XXX11001			
1A	XX11010	XXX11010			
1B	XX11011	XXX11011			
1C	XX11100	XXX11100			
1D	XX11101	XXX11101			
1E	XX11110	XXX11110			
1F	XX11111	XXX11111	ADDP	R/W	Address pointer control register for switching between primary register bank and expanded register bank

Table-17 Primary Register Map

Register	Address R/W Default	Bit 7	Bit 6	Bit 5	Bit 4	Bit 3	Bit 2	Bit 1	Bit 0
ID	00H R Default	ID 7 R 0	ID 6 R 0	ID 5 R 0	ID 4 R 1	ID 3 R 0	ID 2 R 0	ID 1 R 0	ID 0 R 0
ALB	01H R/W Default	ALB 7 R/W 0	ALB 6 R/W 0	ALB 5 R/W 0	ALB 4 R/W 0	ALB 3 R/W 0	ALB 2 R/W 0	ALB 1 R/W 0	ALB 0 R/W 0
RLB	02H R/W Default	RLB 7 R/W 0	RLB 6 R/W 0	RLB 5 R/W 0	RLB 4 R/W 0	RLB 3 R/W 0	RLB 2 R/W 0	RLB 1 R/W 0	RLB 0 R/W 0
TAO	03H R/W Default	TAO 7 R/W 0	TAO 6 R/W 0	TAO 5 R/W 0	TAO 4 R/W 0	TAO 3 R/W 0	TAO 2 R/W 0	TAO 1 R/W 0	TAO 0 R/W 0
LOS	04H R Default	LOS 7 R 0	LOS 6 R 0	LOS 5 R 0	LOS 4 R 0	LOS 3 R 0	LOS 2 R 0	LOS 1 R 0	LOS 0 R 0
DF	05H R Default	DF 7 R 0	DF 6 R 0	DF 5 R 0	DF 4 R 0	DF 3 R 0	DF 2 R 0	DF 1 R 0	DF 0 R 0
LOSM	06H R/W Default	LOSM 7 R/W 0	LOSM 6 R/W 0	LOSM 5 R/W 0	LOSM 4 R/W 0	LOSM 3 R/W 0	LOSM 2 R/W 0	LOSM 1 R/W 0	LOSM 0 R/W 0
DFM	07H R/W Default	DFM 7 R/W 0	DFM 6 R/W 0	DFM 5 R/W 0	DFM 4 R/W 0	DFM 3 R/W 0	DFM 2 R/W 0	DFM 1 R/W 0	DFM 0 R/W 0
LOSI	08H R Default	LOSI 7 R 0	LOSI 6 R 0	LOSI 5 R 0	LOSI 4 R 0	LOSI 3 R 0	LOSI 2 R 0	LOSI 1 R 0	LOSI 0 R 0
DFI	09H R Default	DFI 7 R 0	DFI 6 R 0	DFI 5 R 0	DFI 4 R 0	DFI 3 R 0	DFI 2 R 0	DFI 1 R 0	DFI 0 R 0
RS	0AH W Default	RS 7 W 1	RS 6 W 1	RS 5 W 1	RS 4 W 1	RS 3 W 1	RS 2 W 1	RS 1 W 1	RS 0 W 1
PMON	0BH R/W Default	- R/W 0	- R/W 0	- R/W 0	- R/W 0	MC 3 R/W 0	MC 2 R/W 0	MC 1 R/W 0	MC 0 R/W 0
DLB	0CH R/W Default	DLB 7 R/W 0	DLB 6 R/W 0	DLB 5 R/W 0	DLB 4 R/W 0	DLB 3 R/W 0	DLB 2 R/W 0	DLB 1 R/W 0	DLB 0 R/W 0
LAC	0DH R/W Default	LAC 7 R/W 0	LAC 6 R/W 0	LAC 5 R/W 0	LAC 4 R/W 0	LAC 3 R/W 0	LAC 2 R/W 0	LAC 1 R/W 0	LAC 0 R/W 0
ATAO	0EH R/W Default	ATAO 7 R/W 0	ATAO 6 R/W 0	ATAO 5 R/W 0	ATAO 4 R/W 0	ATAO 3 R/W 0	ATAO 2 R/W 0	ATAO 1 R/W 0	ATAO 0 R/W 0
GCF	0FH R/W Default	- R/W 0	AISE R/W 0	SCPB R/W 0	CODE R/W 0	JADP R/W 0	JABW R/W 0	JACF 1 R/W 0	JACF 0 R/W 0

Table-17 Primary Register Map (Continued)

Register	Address R/W Default	Bit 7	Bit 6	Bit 5	Bit 4	Bit 3	Bit 2	Bit 1	Bit 0
TSIA	10 Hex R/W Default	- R/W 0	- R/W 0	- R/W 0	- R/W 0	- R/W 0	TSIA 2 R/W 0	TSIA 1 R/W 0	TSIA 0 R/W 0
TS	11 Hex R/W Default	- R/W 0	- R/W 0	- R/W 0	- R/W 0	- R/W 0	TS 2 R/W 0	TS 1 R/W 0	TS 0 R/W 0
OE	12 Hex R/W Default	OE 7 R/W 0	OE 6 R/W 0	OE 5 R/W 0	OE 4 R/W 0	OE 3 R/W 0	OE 2 R/W 0	OE 1 R/W 0	OE 0 R/W 0
AIS	13 Hex R Default	AIS 7 R 0	AIS 6 R 0	AIS 5 R 0	AIS 4 R 0	AIS 3 R 0	AIS 2 R 0	AIS 1 R 0	AIS 0 R 0
AISM	14 Hex R/W Default	AISM 7 R/W 0	AISM 6 R/W 0	AISM 5 R/W 0	AISM 4 R/W 0	AISM 3 R/W 0	AISM 2 R/W 0	AISM 1 R/W 0	AISM 0 R/W 0
AISI	15 Hex R Default	AISI 7 R 0	AISI 6 R 0	AISI 5 R 0	AISI 4 R 0	AISI 3 R 0	AISI 2 R 0	AISI 1 R 0	AISI 0 R 0
ADDP	1F Hex R/W Default	ADDP 7 R/W 0	ADDP 6 R/W 0	ADDP 5 R/W 0	ADDP 4 R/W 0	ADDP 3 R/W 0	ADDP 2 R/W 0	ADDP 1 R/W 0	ADDP 0 R/W 0

Table-18 Expanded (Indirect Address Mode) Register Map

Register	Address R/W Default	Bit 7	Bit 6	Bit 5	Bit 4	Bit 3	Bit 2	Bit 1	Bit 0
e-SING	00H R/W Default	SING 7 R/W 0	SING 6 R/W 0	SING 5 R/W 0	SING 4 R/W 0	SING 3 R/W 0	SING 2 R/W 0	SING 1 R/W 0	SING 0 R/W 0
e-CODE	01H R/W Default	CODE 7 R/W 0	CODE 6 R/W 0	CODE 5 R/W 0	CODE 4 R/W 0	CODE 3 R/W 0	CODE 2 R/W 0	CODE 1 R/W 0	CODE 0 R/W 0
e-CRS	02H R/W Default	CRS 7 R/W 0	CRS 6 R/W 0	CRS 5 R/W 0	CRS 4 R/W 0	CRS 3 R/W 0	CRS 2 R/W 0	CRS 1 R/W 0	CRS 0 R/W 0
e-RPDN	03H R/W Default	RPDN 7 R/W 0	RPDN 6 R/W 0	RPDN 5 R/W 0	RPDN 4 R/W 0	RPDN 3 R/W 0	RPDN 2 R/W 0	RPDN 1 R/W 0	RPDN 0 R/W 0
e-TPDN	04H R/W Default	TPDN 7 R/W 0	TPDN 6 R/W 0	TPDN 5 R/W 0	TPDN 4 R/W 0	TPDN 3 R/W 0	TPDN 2 R/W 0	TPDN 1 R/W 0	TPDN 0 R/W 0
e-CZER	05H R/W Default	CZER 7 R/W 0	CZER 6 R/W 0	CZER 5 R/W 0	CZER 4 R/W 0	CZER 3 R/W 0	CZER 2 R/W 0	CZER 1 R/W 0	CZER 0 R/W 0
e-CODV	06H R/W Default	CODV 7 R/W 0	CODV 6 R/W 0	CODV 5 R/W 0	CODV 4 R/W 0	CODV 3 R/W 0	CODV 2 R/W 0	CODV 1 R/W 0	CODV 0 R/W 0
e-EQUA	07H R/W Default	EQUA 7 R/W 0	EQUA 6 R/W 0	EQUA 5 R/W 0	EQUA 4 R/W 0	EQUA 3 R/W 0	EQUA 2 R/W 0	EQUA 1 R/W 0	EQUA 0 R/W 0
e-LBCF	08H R/W Default	- R/W 0	- R/W 0	LBDE R/W 0	ALBE R/W 0	LBAL 1 R/W 0	LBAL 0 R/W 0	LBDL 1 R/W 0	LBDL 0 R/W 0
e-LBAC	09H R/W Default	LBAC 7 R/W 0	LBAC 6 R/W 0	LBAC 5 R/W 0	LBAC 4 R/W 0	LBAC 3 R/W 0	LBAC 2 R/W 0	LBAC 1 R/W 0	LBAC 0 R/W 0
e-LBDC	0AH R/W Default	LBDC 7 R/W 0	LBDC 6 R/W 0	LBDC 5 R/W 0	LBDC 4 R/W 0	LBDC 3 R/W 0	LBDC 2 R/W 0	LBDC 1 R/W 0	LBDC 0 R/W 0
e-LBS	0BH R Default	LBS 7 R 0	LBS 6 R 0	LBS 5 R 0	LBS 4 R 0	LBS 3 R 0	LBS 2 R 0	LBS 1 R 0	LBS 0 R 0
e-LBM	0CH R/W Default	LBM 7 R/W 0	LBM 6 R/W 0	LBM 5 R/W 0	LBM 4 R/W 0	LBM 3 R/W 0	LBM 2 R/W 0	LBM 1 R/W 0	LBM 0 R/W 0
e-LBI	0DH R/W Default	LBI 7 R 0	LBI 6 R 0	LBI 5 R 0	LBI 4 R 0	LBI 3 R 0	LBI 2 R 0	LBI 1 R 0	LBI 0 R 0
e-LBGS	0EH R/W Default	LBGS 7 R/W 0	LBGS 6 R/W 0	LBGS 5 R/W 0	LBGS 4 R/W 0	LBGS 3 R/W 0	LBGS 2 R/W 0	LBGS 1 R/W 0	LBGS 0 R/W 0
e-LBGE	0FH R/W Default	LBGE 7 R/W 0	LBGE 6 R/W 0	LBGE 5 R/W 0	LBGE 4 R/W 0	LBGE 3 R/W 0	LBGE 2 R/W 0	LBGE 1 R/W 0	LBGE 0 R/W 0
ADDP	1FH R/W Default	ADDP 7 R/W 0	ADDP 6 R/W 0	ADDP 5 R/W 0	ADDP 4 R/W 0	ADDP 3 R/W 0	ADDP 2 R/W 0	ADDP 1 R/W 0	ADDP 0 R/W 0

3.2 REGISTER DESCRIPTION

3.2.1 PRIMARY REGISTERS

ID: Device ID Register (R, Address = 00H)

Symbol	Position	Default	Description
ID[7:0]	ID.7-0	10H	An 8-bit word is pre-set into the device as the identification and revision number. This number is different with the functional changes and is mask programmed.

ALB: Analog Loopback Configuration Register (R/W, Address = 01H)

Symbol	Position	Default	Description
ALB[7:0]	ALB.7-0	00H	0 = Normal operation. (Default) 1 = Analog Loopback enabled.

RLB: Remote Loopback Configuration Register (R/W, Address = 02H)

Symbol	Position	Default	Description
RLB[7:0]	RLB.7-0	00H	0 = Normal operation. (Default) 1 = Remote Loopback enabled.

TAO: Transmit All Ones Configuration Register (R/W, Address = 03H)

Symbol	Position	Default	Description
TAO[7:0]	TAO.7-0	00H	0 = Normal operation. (Default) 1 = Transmit all ones.

LOS: Loss of Signal Status Register (R, Address = 04H)

Symbol	Position	Default	Description
LOS[7:0]	LOS.7-0	00H	0 = Normal operation. (Default) 1 = Loss of signal detected.

DF: Driver Fault Status Register (R, Address = 05H)

Symbol	Position	Default	Description
DF[7:0]	DF.7-0	00H	0 = Normal operation. (Default) 1 = Driver fault detected.

LOSM: Loss of Signal Interrupt Mask Register (R/W, Address = 06H)

Symbol	Position	Default	Description
LOSM[7:0]	LOSM.7-0	00H	0 = LOS interrupt is not allowed. (Default) 1 = LOS interrupt is allowed.

DFM: Driver Fault Interrupt Mask Register (R/W, Address = 07H)

Symbol	Position	Default	Description
DFM[7:0]	DFM.7-0	00H	0 = Driver fault interrupt not allowed. (Default) 1 = Driver fault interrupt allowed.

LOSI: Loss of Signal Interrupt Status Register (R, Address = 08H)

Symbol	Position	Default	Description
LOSI[7:0]	LOSI.7-0	00H	0 = (Default). Or after a LOS read operation. 1 = Any transition on LOSn (Corresponding LOSMn is set to '1').

DFI: Driver Fault Interrupt Status Register (R, Address = 09H)

Symbol	Position	Default	Description
DFI[7:0]	DFI.7-0	00H	0 = (Default). Or after a DF read operation. 1 = Any transition on DFn (Corresponding DFMn is set to '1').

RS: Software Reset Register (W, Address = 0AH)

Symbol	Position	Default	Description
RS[7:0]	RS.7-0	FFH	Writing to this register will not change the content in this register but initiate a 1 μs reset cycle, which means all the registers in the device are set to their default values.

PMON: Performance Monitor Configuration Register (R/W, Address = 0BH)

Symbol	Position	Default	Description
-	PMON.7-4	0000	0 = Normal operation. (Default) 1 = Reserved.
MC[3:0]	PMON.3-0	0000	0000 = Normal operation without monitoring (Default) 0001 = Monitor Receiver 1 0010 = Monitor Receiver 2 0011 = Monitor Receiver 3 0100 = Monitor Receiver 4 0101 = Monitor Receiver 5 0110 = Monitor Receiver 6 0111 = Monitor Receiver 7 1000 = Normal operation without monitoring 1001 = Monitor Transmitter 1 1010 = Monitor Transmitter 2 1011 = Monitor Transmitter 3 1100 = Monitor Transmitter 4 1101 = Monitor Transmitter 5 1110 = Monitor Transmitter 6 1111 = Monitor Transmitter 7

DLB: Digital Loopback Configuration Register (R/W, Address = 0CH)

Symbol	Position	Default	Description
DLB[7:0]	DLB.7-0	00H	0 = Normal operation. (Default) 1 = Digital Loopback enabled.

LAC: LOS/AIS Criteria Configuration Register (R/W, Address = 0DH)

Symbol	Position	Default	Description
LAC[7:0]	LAC.7-0	00H	For E1 mode, the criterion is selected as below: 0 = G.775 (Default) 1 = ETSI 300 233 For T1 mode, the criterion meets T1.231.

ATAO: Automatic TAOS Configuration Register (R/W, Address = 0EH)

Symbol	Position	Default	Description
ATAO[7:0]	ATAO.7-0	00H	0 = No automatic transmit all ones. (Default) 1 = Automatic transmit all ones to the line side during LOS.

GCF: Global Configuration Register (R/W, Address = 0FH)

Symbol	Position	Default	Description
-	GCF.7	0	0 = Normal operation. 1 = Reserved.
AISE	GCF.6	0	0 = AIS insertion to the system side disabled on LOS. 1 = AIS insertion to the system side enabled on LOS.
SCPB	GCF.5	0	0 = Short circuit protection is enabled. 1 = Short circuit protection is disabled.
CODE	GCF.4	0	0 = B8ZS/HDB3 encoder/decoder enabled. 1 = AMI encoder/decoder enabled.
JADP	GCF.3	0	Jitter Attenuator Depth Select 0 = 32-bit FIFO (Default) 1 = 64-bit FIFO
JABW	GCF.2	0	Jitter Transfer Function Bandwidth Select 0 = 2.5 Hz (T1); 1.7 Hz (E1) (Default) 1 = 5 Hz; 6.5 Hz
JACF[1:0]	GCF.1-0	00	Jitter Attenuator Configuration 00 = JA not used. (Default) 01 = JA in transmit path 10 = JA not used. 11 = JA in receive path

TSIA: Indirect Address Register for Transmit Template Select Registers (R/W, Address = 10H)

Symbol	Position	Default	Description
-	TSIA.7-3	00000	0 = Normal operation. (Default) 1 = Reserved.
TSIA[2:0]	TSIA.2-0	000	000 = Channel 0 (Default) 001 = Channel 1 010 = Channel 2 011 = Channel 3 100 = Channel 4 101 = Channel 5 110 = Channel 6 111 = Channel 7

TS: Transmit Template Select Register (R/W, Address = 11H)

Symbol	Position	Default	Description		
-	TS.7-3	00000	0 = Normal operation. (Default) 1 = Reserved.		
TS[2:0]	TS.2-0	000	TS[2:0] select one of eight built-in transmit template for different applications.		
			TS[2:0]	Mode	Cable Length
			000	E1	75 Ω coaxial cable/120 Ω twisted pair cable.
			001	Reserved.	
			010	Reserved.	
			011	T1	0 - 133 ft.
			100	T1	133 - 266 ft.
			101	T1	266 - 399 ft.
			110	T1	399 - 533 ft.
111	T1	533 - 655 ft.			

OE: Output Enable Configuration Register (R/W, Address = 12H)

Symbol	Position	Default	Description
OE[7:0]	OE.7-0	00H	0 = Transmit drivers enabled. (Default) 1 = Transmit drivers in high-Z.

AIS: Alarm Indication Signal Status Register (R, Address = 13H)

Symbol	Position	Default	Description
AIS[7:0]	AIS.7-0	00H	0 = Normal operation. (Default) 1 = AIS detected.

AISM: Alarm Indication Signal Interrupt Mask Register (R/W, Address = 14H)

Symbol	Position	Default	Description
AISM[7:0]	AISM.7-0	00H	0 = AIS interrupt is not allowed. (Default) 1 = AIS interrupt is allowed.

AISI: Alarm Indication Signal Interrupt Status Register (R, Address = 15H)

Symbol	Position	Default	Description
AISI[7:0]	AISI.7-0	00H	0 = (Default), or after an AIS read operation 1 = Any transition on AISn. (Corresponding AISMn is set to '1'.)

ADDP: Address Pointer Control Register (R/W, Address = 1F H)

Symbol	Position	Default	Description
ADDP[7:0]	ADDP.7-0	00H	Two kinds of configuration in this register can be set to switch between primary register bank and expanded register bank. When power up, the address pointer will point to the top address of primary register bank automatically. 00H = The address pointer points to the top address of primary register bank (default). AAH = The address pointer points to the top address of expanded register bank.

3.2.2 EXPANDED REGISTER DESCRIPTION

e-SING: Single Rail Mode Setting Register (R/W, Expanded Address = 00H)

Symbol	Position	Default	Description
SING[7:0]	SING.7-0	00H	0 = Pin TDNn selects single rail mode or dual rail mode. (Default) 1 = Single rail mode enabled (with CRSn=0)

e-CODE: Encoder/Decoder Selection Register (R/W, Expanded Address = 01H)

Symbol	Position	Default	Description
CODE[7:0]	CODE.7-0	00H	CODEn selects AMI or B8ZS/HDB3 encoder/decoder on a per channel basis with SINGn = 1 and CRSn = 0. 0 = B8ZS/HDB3 encoder/decoder enabled. (Default) 1 = AMI encoder/decoder enabled.

e-CRS: Clock Recovery Enable/Disable Selection Register (R/W, Expanded Address = 02H)

Symbol	Position	Default	Description
CRS[7:0]	CRS.7-0	00H	0 = Clock recovery enabled. (Default) 1 = Clock recovery disabled.

e-RPDN: Receiver n Powerdown Register (R/W, Expanded Address = 03H)

Symbol	Position	Default	Description
RPDN[7:0]	RPDN.7-0	00H	0 = Normal operation. (Default) 1 = Receiver n is powered down.

e-TPDN: Transmitter n Powerdown Register (R/W, Expanded Address = 04H)

Symbol	Position	Default	Description
TPDN[7:0]	TPDN.7-0	00H	0 = Normal operation. (Default) 1 = Transmitter n is powered down ⁽¹⁾ (the corresponding transmit output driver enters a low power high-Z mode).

¹: Transmitter n is powered down when either pin TCLKn is pulled low or TPDNn is set to '1'

e-CZER: Consecutive Zero Detect Enable/Disable Register (R/W, Expanded Address = 05H)

Symbol	Position	Default	Description
CZER[7:0]	CZER.7-0	00H	0 = Excessive zeros detect disabled. (Default) 1 = Excessive zeros detect enabled for B8ZS/HDB3 decoder in single rail mode.

e-CODV: Code Violation Detect Enable/Disable Register (R/W, Expanded Address = 06H)

Symbol	Position	Default	Description
CODV[7:0]	CODV.7-0	00H	0 = Code Violation Detect enable for B8ZS/HDB3 decoder in single rail mode. (Default) 1 = Code Violation Detect disabled.

e-EQUA: Receive Equalizer Enable/Disable Register (R/W, Expanded Address = 07H)

Symbol	Position	Default	Description
EQUA[7:0]	EQUA.7-0	00H	0 = Normal operation. (Default) 1 = Equalizer in Receiver n is enabled, which can improve the receive performance when transmission length is more than 200 m.

e-LBCF: Inband Loopback Configuration Register ⁽¹⁾(R/W, Expanded Address = 08H)

Symbol	Position	Default	Description
-	LBCF.7-6	00	0 = Normal Operation. (Default) 1 = Reserved.
LBDE	LBCF.5	0	Loopback Detector Enable 0 = Inband loopback code detection is disabled. (Default) 1 = Inband loopback code detection is enabled.
ALBE	LBCF.4	0	Automatic Loopback Enable 0 = Automatic Inband Loopback disabled. 1 = Automatic Inband Loopback enabled.
LBAL[1:0]	LBCF.3-2	00	Loopback Activate Code Length 00 = 5-bit long activate code in LBAC[7:3] is effective. 01 = 6-bit long activate code in LBAC[7:2] is effective. 10 = 7-bit long activate code in LBAC[7:1] is effective. 11 = 8-bit long activate code in LBAC[7:0] is effective.
LBDL[1:0]	LBCF.1-0	00	Loopback Deactivate Code Length 00 = 5-bit long deactivate code in LBDC[7:3] is effective. 01 = 6-bit long deactivate code in LBDC[7:2] is effective. 10 = 7-bit long deactivate code in LBDC[7:1] is effective. 11 = 8-bit long deactivate code in LBDC[7:0] is effective.

¹. This register is global control.

e-LBAC: Inband Loopback Activation Code Register ⁽¹⁾⁽²⁾(R/W, Expanded Address = 09H)

Symbol	Position	Default	Description
LBAC[7:0]	LBAC.7-0	00H	LBAC[7:0] = 8-bit (or 4-bit) repeating activate code is programmed with the length limitation in LBAL[1:0]. LBAC[7:1] = 7-bit repeating activate code is programmed with the length limitation in LBAL[1:0]. LBAC[7:2] = 6-bit (or 3-bit) repeating activate code is programmed with the length limitation in LBAL[1:0]. LBAC[7:3] = 5-bit repeating activate code is programmed with the length limitation in LBAL[1:0].

¹. When setting a value in e-LBAC or e-LBDC that is less than 8 bits, the most significant bits must be replicated in the unused least significant bits. e.g. if setting a 5-bit code = 11000, the register value should be 11000110. Here b7 is repeated in b2; b6 is repeated in b1; b5 is repeated in b0.

². This register is global control.

e-LBDC: Inband Loopback Deactivation Code Register ⁽¹⁾⁽²⁾(R/W, Expanded Address = 0AH)

Symbol	Position	Default	Description
LBDC[7:0]	LBDC.7-0	00H	LBDC[7:0] = 8-bit (or 4-bit) repeating deactivate code is programmed with the length limitation set by LBDL[1:0] bits. LBDC[7:1] = 7-bit repeating deactivate code is programmed with the length limitation set by LBDL[1:0] bits. LBDC[7:2] = 6-bit (or 3-bit) repeating deactivate code is programmed with the length limitation set by LBDL[1:0] bits. LBDC[7:3] = 5-bit repeating deactivate code is programmed with the length limitation set by LBDL[1:0] bits.

¹. When setting a value in e-LBAC or e-LBDC that is less than 8 bits, the most significant bits must be replicated in the unused least significant bits. e.g. if setting a 5-bit code = 11000, the register value should be 11000110. Here b7 is repeated in b2; b6 is repeated in b1; b5 is repeated in b0.

². This register is global control.

e-LBS: Inband Loopback Receive Status Register (R, Expanded Address = 0BH)

Symbol	Position	Default	Description
LBS[7:0]	LBS.7-0	00H	0 = Normal operation (Default). Or loopback deactivation code detected. 1 = Loopback activation code detected.

e-LBM: Inband Loopback Interrupt Mask Register (R/W, Expanded Address = 0CH)

Symbol	Position	Default	Description
LBM[7:0]	LBM.7-0	00H	0 = LBI interrupt is not allowed (Default) 1 = LBI interrupt is allowed.

e-LBI: Inband Loopback Interrupt Status Register (R, Expanded Address = 0DH)

Symbol	Position	Default	Description
LBI[7:0]	LBI.7-0	00H	0 = (Default). Or after a read of e-LBS operation. 1 = Any transition on e-LBSn. (Corresponding e-LBMn and bit LBDE in e-LBCF are both set to 1.)

e-LBGS: Inband Loopback Activate/Deactivate Code Generator Selection Register (R/W, Expanded Address = 0EH)

Symbol	Position	Default	Description
LBGS[7:0]	LBGS.7-0	00H	0 = Activate Code Generator is selected in Transmitter n. (Default) 1 = Deactivate Code Generator is selected in Transmitter n.

e-LBGE: Inband Loopback Activate/Deactivate Code Generator Enable Register (R/W, Expanded Address = 0FH)

Symbol	Position	Default	Description
LBGE[7:0]	LBGE.7-0	00H	0 = Activate/Deactivate Code Generator for inband loopback is disabled in Transmitter n. (Default) 1 = Activate/Deactivate Code Generator for inband loopback is enabled in Transmitter n.

4 IEEE STD 1149.1 JTAG TEST ACCESS PORT

The IDT82V2048 supports the digital Boundary Scan Specification as described in the IEEE 1149.1 standards.

The boundary scan architecture consists of data and instruction registers plus a Test Access Port (TAP) controller. Control of the TAP is achieved through signals applied to the TMS and TCK pins. Data is shifted into the registers via the TDI pin, and shifted out of the registers via the TDO pin. JTAG test data are clocked at a rate determined by JTAG test clock.

The JTAG boundary scan registers includes BSR (Boundary Scan Register), IDR (Device Identification Register), BR (Bypass Register) and IR (Instruction Register). These will be described in the following pages. Refer to [Figure-25](#) for architecture.

4.1 JTAG INSTRUCTIONS AND INSTRUCTION REGISTER (IR)

The IR with instruction decode block is used to select the test to be executed or the data register to be accessed or both.

The instructions are shifted in LSB first to this 3-bit register. See [Table-19 Instruction Register Description on page 41](#) for details of the codes and the instructions related.

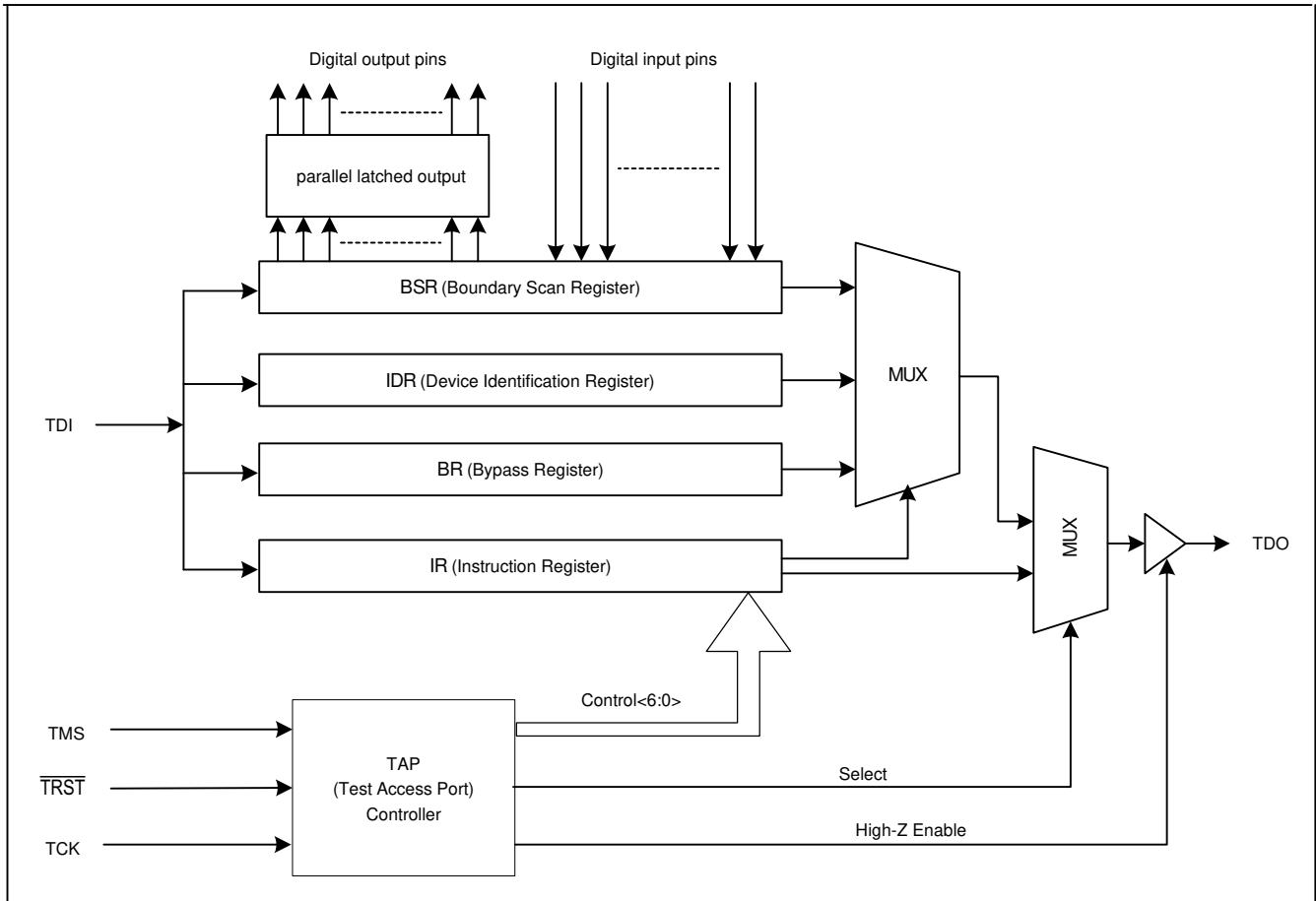

Figure-25 JTAG Architecture

Table-19 Instruction Register Description

IR Code	Instruction	Comments
000	Extest	The external test instruction allows testing of the interconnection to other devices. When the current instruction is the EXTEST instruction, the boundary scan register is placed between TDI and TDO. The signal on the input pins can be sampled by loading the boundary scan register using the Capture-DR state. The sampled values can then be viewed by shifting the boundary scan register using the Shift-DR state. The signal on the output pins can be controlled by loading patterns shifted in through input TDI into the boundary scan register using the Update-DR state.
100	Sample/Preload	The sample instruction samples all the device inputs and outputs. For this instruction, the boundary scan register is placed between TDI and TDO. The normal path between IDT82V2048 logic and the I/O pins is maintained. Primary device inputs and outputs can be sampled by loading the boundary scan register using the Capture-DR state. The sampled values can then be viewed by shifting the boundary scan register using the Shift-DR state.
110	Idcode	The identification instruction is used to connect the identification register between TDI and TDO. The device's identification code can then be shifted out using the Shift-DR state.
111	Bypass	The bypass instruction shifts data from input TDI to output TDO with one TCK clock period delay. The instruction is used to bypass the device.

Table-20 Device Identification Register Description

Bit No.	Comments
0	Set to '1'
1~11	Producer Number
12~27	Part Number
28~31	Device Revision

4.2 JTAG DATA REGISTER

4.2.1 DEVICE IDENTIFICATION REGISTER (IDR)

The IDR can be set to define the producer number, part number and the device revision, which can be used to verify the proper version or revision number that has been used in the system under test. The IDR is 32 bits long and is partitioned as in [Table-20](#). Data from the IDR is shifted out to TDO LSB first.

Table-21 Boundary Scan Register Description

Bit No.	Bit Symbol	Pin Signal	Type	Comments
0	POUT0	LP0	I/O	
1	PIN0	LP0	I/O	
2	POUT1	LP1	I/O	
3	PIN1	LP1	I/O	
4	POUT2	LP2	I/O	
5	PIN2	LP2	I/O	
6	POUT3	LP3	I/O	
7	PIN3	LP3	I/O	
8	POUT4	LP4	I/O	
9	PIN4	LP4	I/O	
10	POUT5	LP5	I/O	
11	PIN5	LP5	I/O	
12	POUT6	LP6	I/O	
13	PIN6	LP6	I/O	
14	POUT7	LP7	I/O	
15	PIN7	LP7	I/O	

4.2.2 BYPASS REGISTER (BR)

The BR consists of a single bit. It can provide a serial path between the TDI input and TDO output, bypassing the BSR to reduce test access times.

4.2.3 BOUNDARY SCAN REGISTER (BSR)

The BSR can apply and read test patterns in parallel to or from all the digital I/O pins. The BSR is a 98 bits long shift register and is initialized and read using the instruction EXTEST or SAMPLE/PRELOAD. Each pin is related to one or more bits in the BSR. Please refer to [Table-21](#) for details of BSR bits and their functions.

Table-21 Boundary Scan Register Description (Continued)

Bit No.	Bit Symbol	Pin Signal	Type	Comments
16	PIOS	N/A	-	Controls pins LP[7:0]. When '0', the pins are configured as outputs. The output values to the pins are set in POUT 7~0. When '1', the pins are high-Z. The input values to the pins are read in PIN 7~0.
17	TCLK1	TCLK1	I	
18	TDP1	TDP1	I	
19	TDN1	TDN1	I	
20	RCLK1	RCLK1	O	
21	RDP1	RDP1	O	
22	RDN1	RDN1	O	
23	HZEN1	N/A	-	Controls pin RDP1, RDN1 and RCLK1. When '0', the outputs are enabled on the pins. When '1', the pins are high-Z.
24	LOS1	LOS1	O	
25	TCLK0	TCLK0	I	
26	TDP0	TDP0	I	
27	TDN0	TDN0	I	
28	RCLK0	RCLK0	O	
29	RDP0	RDP0	O	
30	RDN0	RDN0	O	
31	HZEN0	N/A	-	Controls pin RDP0, RDN0 and RCLK0. When '0', the outputs are enabled on the pins. When '1', the pins are high-Z.
32	LOS0	LOS0	O	
33	MODE1	MODE1	I	
34	LOS3	LOS3	O	
35	RDN3	RDN3	O	
36	RDP3	RDP3	O	
37	HZEN3	N/A	-	Controls pin RDP3, RDN3 and RCLK3. When '0', the outputs are enabled on the pins. When '1', the pins are high-Z.
38	RCLK3	RCLK3	O	
39	TDN3	TDN3	I	
40	TDP3	TDP3	I	
41	TCLK3	TCLK3	I	
42	LOS2	LOS2	O	
43	RDN2	RDN2	O	
44	RDP2	RDP2	O	
45	HZEN2	N/A	-	Controls pin RDP2, RDN2 and RCLK2. When '0', the outputs are enabled on the pins. When '1', the pins are high-Z.
46	RCLK2	RCLK2	O	
47	TDN2	TDN2	I	
48	TDP2	TDP2	I	
49	TCLK2	TCLK2	I	
50	INT	INT	O	
51	ACK	ACK	O	
52	SDORDYS	N/A	-	Control pin ACK. When '0', the output is enabled on pin $\overline{\text{ACK}}$. When '1', the pin is high-Z.
53	WRB	$\overline{\text{DS}}$	I	
54	RDB	R/W	I	
55	ALE	ALE	I	
56	CSB	$\overline{\text{CS}}$	I	

Table-21 Boundary Scan Register Description (Continued)

Bit No.	Bit Symbol	Pin Signal	Type	Comments
57	MODE0	MODE0	I	
58	TCLK5	TCLK5	I	
59	TDP5	TDP5	I	
60	TDN5	TDN5	I	
61	RCLK5	RCLK5	O	
62	RDP5	RDP5	O	
63	RDN5	RDN5	O	
64	HZEN5	N/A	-	Controls pin RDP5, RDN5 and RCLK5. When '0', the outputs are enabled on the pins. When '1', the pins are high-Z.
65	LOS5	LOS5	O	
66	TCLK4	TCLK4	I	
67	TDP4	TDP4	I	
68	TDN4	TDN4	I	
69	RCLK4	RCLK4	O	
70	RDP4	RDP4	O	
71	RDN4	RDN4	O	
72	HZEN4	N/A	-	Controls pin RDP4, RDN4 and RCLK4. When '0', the outputs are enabled on the pins. When '1', the pins are high-Z.
73	LOS4	LOS4	O	
74	OE	OE	I	
75	CLKE	CLKE	I	
76	LOS7	LOS7	O	
77	RDN7	RDN7	O	
78	RDP7	RDP7	O	
79	HZEN7	N/A	-	Controls pin RDP7, RDN7 and RCLK7. When '0', the outputs are enabled on the pins. When '1', the pins are high-Z.
80	RCLK7	RCLK7	O	
81	TDN7	TDN7	I	
82	TDP7	TDP7	I	
83	TCLK7	TCLK7	I	
84	LOS6	LOS6	O	
85	RDN6	RDN6	O	
86	RDP6	RDP6	O	
87	HZEN6	N/A	-	Controls pin RDP6, RDN6 and RCLK6. When '0', the outputs are enabled on the pins. When '1', the pins are high-Z.
88	RCLK6	RCLK6	O	
89	TDN6	TDN6	I	
90	TDP6	TDP6	I	
91	TCLK6	TCLK6	I	
92	MCLK	MCLK	I	
93	MODE2	MODE2	I	
94	A4	A4	I	
95	A3	A3	I	
96	A2	A2	I	
97	A1	A1	I	
98	A0	A0	I	

4.3 TEST ACCESS PORT CONTROLLER

The TAP controller is a 16-state synchronous state machine. [Figure-26](#) shows its state diagram. A description of each state follows. Note that the figure contains two main branches to access either the data or

instruction registers. The value shown next to each state transition in this figure states the value present at TMS at each rising edge of TCK. Refer to [Table-22](#) for details of the state description.

Table-22 TAP Controller State Description

State	Description
Test Logic Reset	In this state, the test logic is disabled. The device is set to normal operation. During initialization, the device initializes the instruction register with the IDCODE instruction. Regardless of the original state of the controller, the controller enters the Test-Logic-Reset state when the TMS input is held high for at least 5 rising edges of TCK. The controller remains in this state while TMS is high. The device processor automatically enters this state at power-up.
Run-Test/Idle	This is a controller state between scan operations. Once in this state, the controller remains in the state as long as TMS is held low. The instruction register and all test data registers retain their previous state. When TMS is high and a rising edge is applied to TCK, the controller moves to the Select-DR state.
Select-DR-Scan	This is a temporary controller state and the instruction does not change in this state. The test data register selected by the current instruction retains its previous state. If TMS is held low and a rising edge is applied to TCK when in this state, the controller moves into the Capture-DR state and a scan sequence for the selected test data register is initiated. If TMS is held high and a rising edge applied to TCK, the controller moves to the Select-IR-Scan state.
Capture-DR	In this state, the Boundary Scan Register captures input pin data if the current instruction is EXTEST or SAMPLE/PRELOAD. The instruction does not change in this state. The other test data registers, which do not have parallel input, are not changed. When the TAP controller is in this state and a rising edge is applied to TCK, the controller enters the Exit1-DR state if TMS is high or the Shift-DR state if TMS is low.
Shift-DR	In this controller state, the test data register connected between TDI and TDO as a result of the current instruction shifts data on stage toward its serial output on each rising edge of TCK. The instruction does not change in this state. When the TAP controller is in this state and a rising edge is applied to TCK, the controller enters the Exit1-DR state if TMS is high or remains in the Shift-DR state if TMS is low.
Exit1-DR	This is a temporary state. While in this state, if TMS is held high, a rising edge applied to TCK causes the controller to enter the Update-DR state, which terminates the scanning process. If TMS is held low and a rising edge is applied to TCK, the controller enters the Pause-DR state. The test data register selected by the current instruction retains its previous value and the instruction does not change during this state.
Pause-DR	The pause state allows the test controller to temporarily halt the shifting of data through the test data register in the serial path between TDI and TDO. For example, this state could be used to allow the tester to reload its pin memory from disk during application of a long test sequence. The test data register selected by the current instruction retains its previous value and the instruction does not change during this state. The controller remains in this state as long as TMS is low. When TMS goes high and a rising edge is applied to TCK, the controller moves to the Exit2-DR state.
Exit2-DR	This is a temporary state. While in this state, if TMS is held high, a rising edge applied to TCK causes the controller to enter the Update-DR state, which terminates the scanning process. If TMS is held low and a rising edge is applied to TCK, the controller enters the Shift-DR state. The test data register selected by the current instruction retains its previous value and the instruction does not change during this state.
Update-DR	The Boundary Scan Register is provided with a latched parallel output to prevent changes while data is shifted in response to the EXTEST and SAMPLE/PRELOAD instructions. When the TAP controller is in this state and the Boundary Scan Register is selected, data is latched into the parallel output of this register from the shift-register path on the falling edge of TCK. The data held at the latched parallel output changes only in this state. All shift-register stages in the test data register selected by the current instruction retain their previous value and the instruction does not change during this state.
Select-IR-Scan	This is a temporary controller state. The test data register selected by the current instruction retains its previous state. If TMS is held low and a rising edge is applied to TCK when in this state, the controller moves into the Capture-IR state, and a scan sequence for the instruction register is initiated. If TMS is held high and a rising edge is applied to TCK, the controller moves to the Test-Logic-Reset state. The instruction does not change during this state.
Capture-IR	In this controller state, the shift register contained in the instruction register loads a fixed value of '100' on the rising edge of TCK. This supports fault-isolation of the board-level serial test data path. Data registers selected by the current instruction retain their value and the instruction does not change during this state. When the controller is in this state and a rising edge is applied to TCK, the controller enters the Exit1-IR state if TMS is held high, or the Shift-IR state if TMS is held low.
Shift-IR	In this state, the shift register contained in the instruction register is connected between TDI and TDO and shifts data one stage towards its serial output on each rising edge of TCK. The test data register selected by the current instruction retains its previous value and the instruction does not change during this state. When the controller is in this state and a rising edge is applied to TCK, the controller enters the Exit1-IR state if TMS is held high, or remains in the Shift-IR state if TMS is held low.

Table-22 TAP Controller State Description (Continued)

State	Description
Exit1-IR	This is a temporary state. While in this state, if TMS is held high, a rising edge applied to TCK causes the controller to enter the Update-IR state, which terminates the scanning process. If TMS is held low and a rising edge is applied to TCK, the controller enters the Pause-IR state. The test data register selected by the current instruction retains its previous value and the instruction does not change during this state.
Pause-IR	The pause state allows the test controller to temporarily halt the shifting of data through the instruction register. The test data register selected by the current instruction retains its previous value and the instruction does not change during this state. The controller remains in this state as long as TMS is low. When TMS goes high and a rising edge is applied to TCK, the controller moves to the Exit2-IR state.
Exit2-IR	This is a temporary state. While in this state, if TMS is held high, a rising edge applied to TCK causes the controller to enter the Update-IR state, which terminates the scanning process. If TMS is held low and a rising edge is applied to TCK, the controller enters the Shift-IR state. The test data register selected by the current instruction retains its previous value and the instruction does not change during this state.
Update-IR	The instruction shifted into the instruction register is latched into the parallel output from the shift-register path on the falling edge of TCK. When the new instruction has been latched, it becomes the current instruction. The test data registers selected by the current instruction retain their previous value.

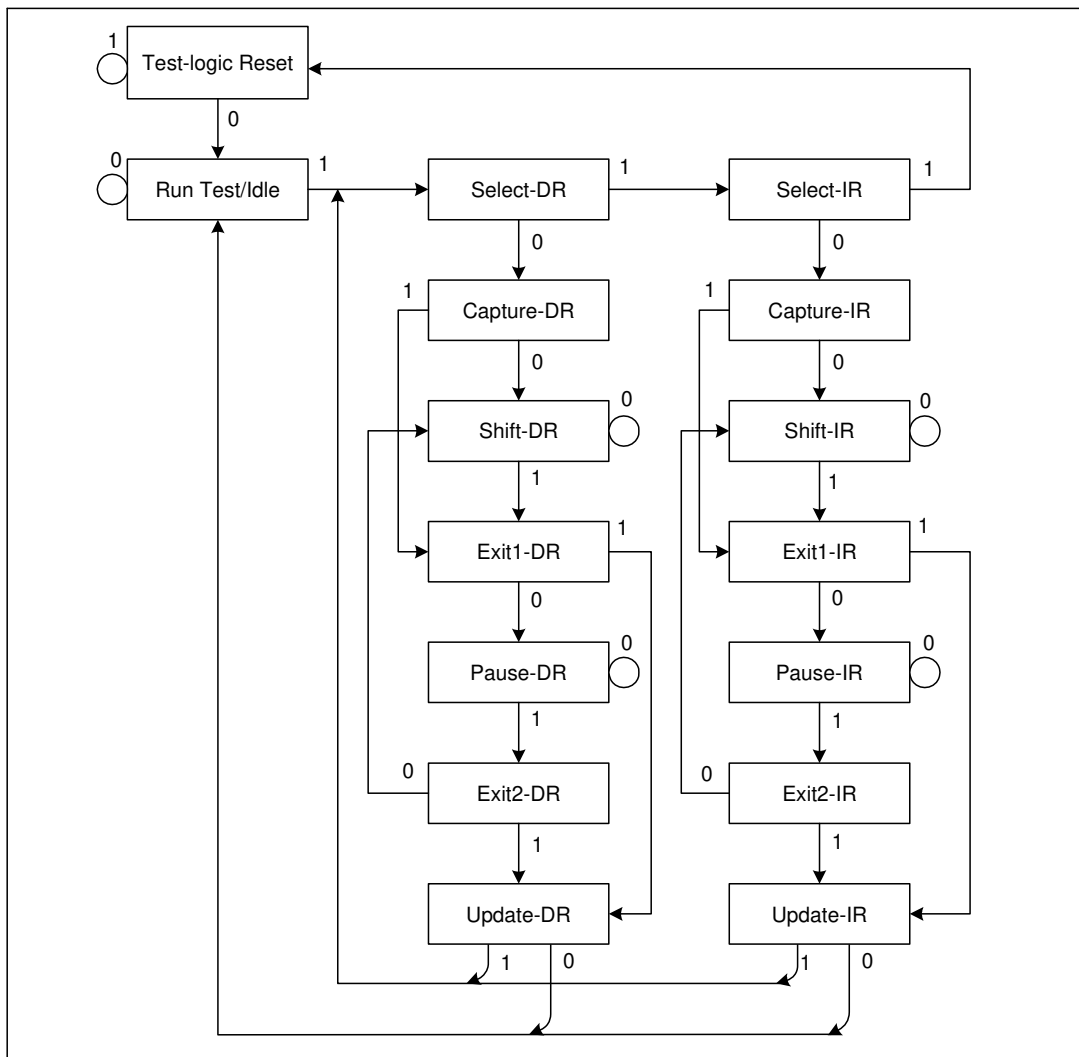

Figure-26 JTAG State Diagram

ABSOLUTE MAXIMUM RATING

Symbol	Parameter	Min	Max	Unit
VDDA, VDDD	Core Power Supply	-0.5	4.0	V
VDDIO0, VDDIO1	I/O Power Supply	-0.5	4.0	V
VDDT0-7	Transmit Power Supply	-0.5	7.0	V
Vin	Input Voltage, any digital pin	GND-0.5	5.5	V
	Input Voltage ⁽¹⁾ , RTIPn pins and RRINGn pins	GND-0.5	VDDA+ 0.5 VDDD+ 0.5	V V
	ESD Voltage, any pin ⁽²⁾	2000		V
Iin	Transient Latch-up Current, any pin		100	mA
	Input Current, any digital pin ⁽³⁾	-10	10	mA
	DC Input Current, any analog pin ⁽³⁾		±100	mA
Pd	Maximum Power Dissipation in package		1.6	W
Tc	Case Temperature		120	°C
Ts	Storage Temperature	-65	+150	°C

CAUTION: Exceeding these values may cause permanent damage. Functional operation under these conditions is not implied. Exposure to absolute maximum rating conditions for extended periods may affect device reliability.

¹. Referenced to ground

². Human body model

³. Constant input current

RECOMMENDED OPERATING CONDITIONS

Symbol	Parameter	Min	Typ	Max	Unit
VDDA, VDDD	Core Power Supply	3.13	3.3	3.47	V
VDDIO	I/O Power Supply	3.13	3.3	3.47	V
VDDT ⁽¹⁾	Transmitter Supply				
	3.3 V	3.13	3.3	3.47	V
	5 V	4.75	5.0	5.25	V
T _A	Ambient Operating Temperature	-40	25	85	°C
R _L	Output load at TTIPn pins and TRINGn pins	25			Ω
I _{VDD}	Average Core Power Supply Current ⁽²⁾		55	65	mA
I _{VDDIO}	I/O Power Supply Current ⁽³⁾		15	25	mA
I _{VDDT}	Average transmitter power supply current, T1 mode ^{(2),(4),(5)}				
	50% ones density data:			230	mA
	100% ones density data:			440	mA

¹. T1 is only 5V VDDT.

². Maximum power and current consumption over the full operating temperature and power supply voltage range. Includes all channels.

³. Digital output is driving 50 pF load, digital input is within 10% of the supply rails.

⁴. T1 maximum values measured with maximum cable length (TS[2:0] = 111). Typical values measured with typical cable length (TS[2:0] = 101).

⁵. Power consumption includes power absorbed by line load and external transmitter components.

POWER CONSUMPTION

Symbol	Parameter	TS[2:0]	Min	Typ	Max ⁽¹⁾⁽²⁾	Unit
	E1, 3.3 V, 75 Ω Load					
	50% ones density data:	000	-	662	-	mW
	100% ones density data:	000	-	1100	1177	mW
	E1, 3.3 V, 120 Ω Load					
	50% ones density data:	000	-	576	-	mW
	100% ones density data:	000	-	930	992	mW
	E1, 5.0 V, 75 Ω Load					
	50% ones density data:	000	-	910	-	mW
	100% ones density data:	000	-	1585	1690	mW
	E1, 5.0 V, 120 Ω Load					
	50% ones density data:	000	-	785	-	mW
	100% ones density data:	000	-	1315	1410	mW
	T1, 5.0 V, 100 Ω Load ⁽³⁾					
	50% ones density data:	101	-	1185	-	mW
	100% ones density data:	111	-	2395	2670	mW

¹ Maximum power and current consumption over the full operating temperature and power supply voltage range. Includes all channels.

² Power consumption includes power absorbed by line load and external transmitter components.

³ T1 maximum values measured with maximum cable length (TS[2:0] = 111). Typical values measured with typical cable length (TS[2:0] = 101).

DC CHARACTERISTICS

Symbol	Parameter	Min	Typ	Max	Unit
V _{IL}	Input Low Level Voltage				
	MODE2, JAS and LPn pins			$\frac{1}{3} V_{DDIO}-0.2$	V
	All other digital inputs pins			0.8	V
V _{IM}	Input Mid Level Voltage				
	MODE2, JAS and LPn pins	$\frac{1}{3} V_{DDIO}+0.2$	$\frac{1}{2} V_{DDIO}$	$\frac{2}{3} V_{DDIO}-0.2$	V
V _{IH}	Input High Voltage				
	MODE2, JAS and LPn pins	$\frac{2}{3} V_{DDIO}+0.2$			V
	All other digital inputs pins	2.0			V
V _{OL}	Output Low level Voltage ⁽¹⁾ (I _{out} = 1.6 mA)			0.4	V
V _{OH}	Output High level Voltage ⁽¹⁾ (I _{out} = 400 μA)	2.4		V _{DDIO}	V
V _{MA}	Analog Input Quiescent Voltage (RTIPn/RRINGn pin while floating)	1.33	1.4	1.47	V
I _H	Input High Level Current (MODE2, JAS and LPn pin)			50	μA
I _L	Input Low Level Current (MODE2, JAS and LPn pin)			50	μA
I _I	Input Leakage Current				
	TMS, TDI and \overline{TRST} pins			50	μA
	All other digital input pins	-10		10	μA
I _{ZL}	High-Z Leakage Current	-10		10	μA
Z _{OH}	Output High-Z on TTIPn pins and TRINGn pins	150			kΩ

¹ Output drivers will output CMOS logic levels into CMOS loads.

TRANSMITTER CHARACTERISTICS

Symbol	Parameter	Min	Typ	Max	Unit	
V_{o-p}	Output Pulse Amplitudes ⁽¹⁾					
	E1, 75 Ω load	2.14	2.37	2.6	V	
	E1, 120 Ω load	2.7	3.0	3.3	V	
	T1, 100 Ω load	2.4	3.0	3.6	V	
V_{o-s}	Zero (space) Level					
	E1, 75 Ω load	-0.237		0.237	V	
	E1, 120 Ω load	-0.3		0.3	V	
	T1, 100 Ω load	-0.15		0.15	V	
	Transmit Amplitude Variation with supply	-1		+1	%	
	Difference between pulse sequences for 17 consecutive pulses			200	mV	
T_{PW}	Output Pulse Width at 50% of nominal amplitude					
	E1:	232	244	256	ns	
	T1:	338	350	362	ns	
	Ratio of the amplitudes of Positive and Negative Pulses at the center of the pulse interval	0.95		1.05		
RTX	Transmit Return Loss ⁽²⁾					
	E1, 75 Ω	51 kHz – 102 kHz	15			dB
		102 kHz – 2.048 MHz	15			dB
		2.048 MHz – 3.072 MHz	15			dB
	E1, 120 Ω	51 kHz – 102 kHz	15			dB
		102 kHz – 2.048 MHz	15			dB
		2.048 MHz – 3.072 MHz	15			dB
	T1 (VDDT = 5 V)	51 kHz – 102 kHz	15			dB
		102 kHz – 2.048 MHz	15			dB
		2.048 MHz – 3.072 MHz	15			dB
	JTX_{p-p}	Intrinsic Transmit Jitter (TCLK is jitter free, JA enabled)				
		E1: 20 Hz – 100 kHz		0.050		U.I.
T1: 10 Hz – 8 kHz			0.020		U.I.p-p	
8 kHz – 40 kHz			0.025		U.I.p-p	
	10 Hz – 40 kHz		0.025		U.I.p-p	
	Wide Band		0.050		U.I.p-p	
T_d	Transmit Path Delay (JA is disabled)					
	Single Rail		8		U.I.	
	Dual Rail		3		U.I.	
I_{SC}	Line Short Circuit Current ⁽³⁾		180		mAp	

¹ E1: measured at the line output ports; T1: measured at the DSX

² Test at IDT82V2048 evaluation board

³ Measured on device, between TTIPn and TRINGn

RECEIVER CHARACTERISTICS

Symbol	Parameter	Min	Typ	Max	Unit
ATT	Permissible Cable Attenuation (E1: @ 1024 kHz, T1: @ 772 kHz)			15	dB
IA	Input Amplitude	0.1		0.9	Vp
SIR	Signal to Interference Ratio Margin ⁽¹⁾	-15			dB
SRE	Data Decision Threshold (refer to peak input voltage)		50		%
	Data Slicer Threshold		150		mV
	Analog Loss Of Signal ⁽²⁾ Declare/Clear:	120/150	200/250	280/350	mVp
	Allowable consecutive zeros before LOS E1, G.775: E1, ETSI 300 233: T1, T1.231-1993		32 2048 175		
	LOS Reset Clock Recovery Mode	12.5			% ones
JRX _{p-p}	Peak to Peak Intrinsic Receive Jitter (JA disabled) E1 (wide band): T1 (wide band):			0.0625 0.0625	U.I. U.I.
JTRX	Jitter Tolerance				
	E1: 1 Hz – 20 Hz	18.0			U.I.
	20 Hz – 2.4 kHz	1.5			U.I.
	18 kHz – 100 kHz	0.2			U.I.
	T1: 0.1 Hz – 1 Hz	138.0			U.I.
	4.9 Hz – 300 Hz	28.0			U.I.
	10 kHz – 100 kHz	0.4			U.I.
ZDM	Receiver Differential Input Impedance		120		k Ω
ZCM	Receiver Common Mode Input Impedance to GND	10			k Ω
RRX	Receive Return Loss 51 kHz – 102 kHz 102 kHz – 2.048 MHz 2.048 MHz – 3.072 MHz	20 20 20			dB dB dB
	Receive Path Delay Dual Rail Single Rail		3 8		U.I. U.I.

¹: E1: per G.703, O.151 @ 6 dB cable attenuation. T1: @ 655 ft. of 22 ABAM cable

²: Measured on device, between RTIP and RRING, all ones signal.

JITTER ATTENUATOR CHARACTERISTICS

Symbol	Parameter	Min	Typ	Max	Unit	
f _{-3dB}	Jitter Transfer Function Corner Frequency (-3 dB)					
	Host mode	E1, 32/64 bit FIFO				
		JABW = 0:		1.7		Hz
		JABW = 1:		6.6		Hz
		T1, 32/64 bit FIFO				
JABW = 0:		2.5		Hz		
JABW = 1:		5		Hz		
Hardware mode	E1		1.7		Hz	
	T1		2.5		Hz	
	Jitter Attenuator					
	E1 ⁽¹⁾ :					
	@ 3 Hz	-0.5			dB	
	@ 40 Hz	-0.5			dB	
	@ 400 Hz	+19.5			dB	
	@ 100 kHz	+19.5			dB	
	T1 ⁽²⁾ :					
	@ 1 Hz	0			dB	
	@ 20 Hz	0			dB	
	@ 1 kHz	+33.3			dB	
@ 1.4 kHz	40			dB		
@ 70 kHz	40			dB		
td	Jitter Attenuator Latency Delay					
	32 bit FIFO:		16		U.I.	
	64 bit FIFO:		32		U.I.	
	Input Jitter Tolerance before FIFO Overflow Or Underflow					
	32 bit FIFO:		28		U.I.	
	64 bit FIFO:		56		U.I.	
	Output Jitter in Remote Loopback ⁽³⁾					
				0.11	U.I.	

¹. Per G.736, see [Figure-43 on page 61](#).

². Per AT&T pub.62411, see [Figure-44 on page 61](#).

³. Per ETSI CTR12/13 output jitter.

TRANSCEIVER TIMING CHARACTERISTICS

Symbol	Parameter	Min	Typ	Max	Unit
	MCLK Frequency				
	E1:		2.048		MHz
	T1:		1.544		MHz
	MCLK Tolerance	-100		100	ppm
	MCLK Duty Cycle	40		60	%
Transmit Path					
	TCLK Frequency				
	E1:		2.048		MHz
	T1:		1.544		MHz
	TCLK Tolerance	-50		+50	ppm
	TCLK Duty Cycle	10		90	%
t1	Transmit Data Setup Time	40			ns
t2	Transmit Data Hold Time	40			ns
	Delay time of OE low to driver High-Z			1	μ s
	Delay time of TCLK low to driver High-Z	40	44	48	μ s
Receive Path					
	Clock Recovery Capture Range ⁽¹⁾				
	E1:		± 80		ppm
	T1:		± 180		ppm
	RCLK Duty Cycle ⁽²⁾	40	50	60	%
t4	RCLK Pulse Width ⁽²⁾				
	E1:	457	488	519	ns
	T1:	607	648	689	ns
t5	RCLK Pulse Width Low Time				
	E1:	203	244	285	ns
	T1:	259	324	389	ns
t6	RCLK Pulse Width High Time				
	E1:	203	244	285	ns
	T1:	259	324	389	ns
	Rise/Fall Time ⁽³⁾	5		30	ns
t7	Receive Data Setup Time				
	E1:	200	244		ns
	T1:	200	324		ns
t8	Receive Data Hold Time				
	E1:	200	244		ns
	T1:	200	324		ns
t9	RDPn/RDNn Pulse Width (MCLK = High) ⁽⁴⁾				
	E1:	200	244		ns
	T1:	300	324		ns

¹. Relative to nominal frequency, MCLK = ± 100 ppm

². RCLK duty cycle widths will vary depending on extent of received pulse jitter displacement. Maximum and minimum RCLK duty cycles are for worst case jitter conditions (0.2 UI displacement for E1 per ITU G.823).

³. For all digital outputs. C load = 15 pF

⁴. Clock recovery is disabled in this mode.

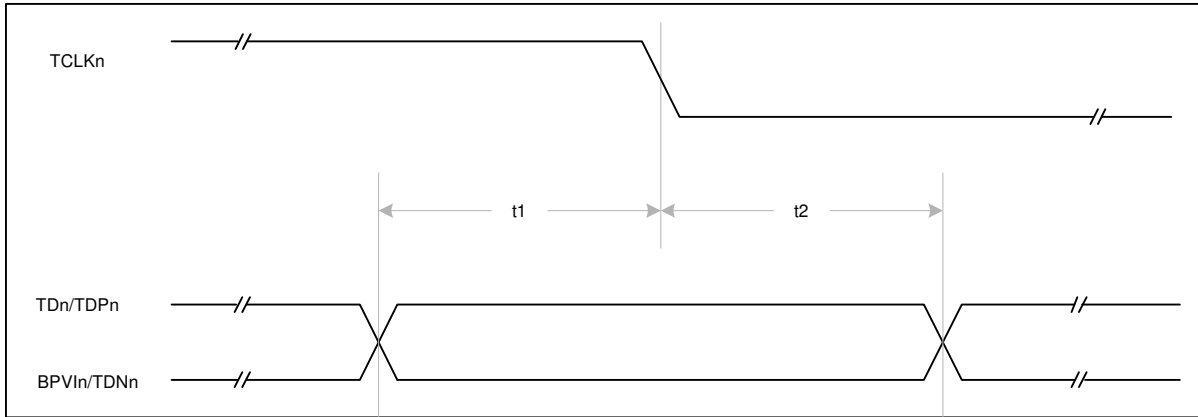

Figure-27 Transmit System Interface Timing

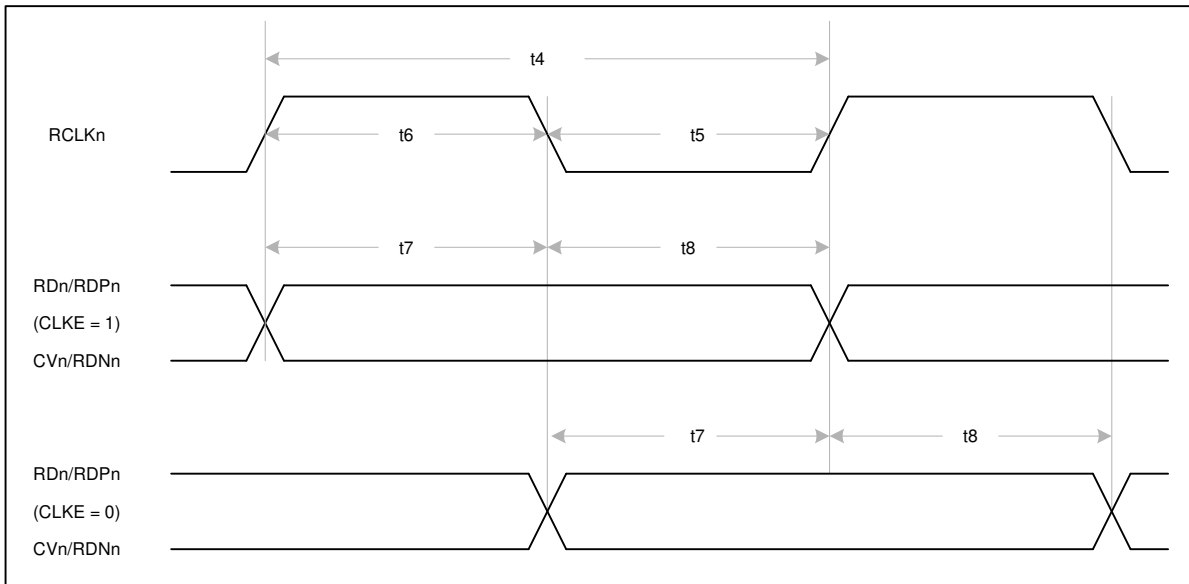

Figure-28 Receive System Interface Timing

JTAG TIMING CHARACTERISTICS

Symbol	Parameter	Min	Typ	Max	Unit	Comments
t1	TCK Period	200			ns	
t2	TMS to TCK setup Time TDI to TCK Setup Time	50			ns	
t3	TCK to TMS Hold Time TCK to TDI Hold Time	50			ns	
t4	TCK to TDO Delay Time			100	ns	

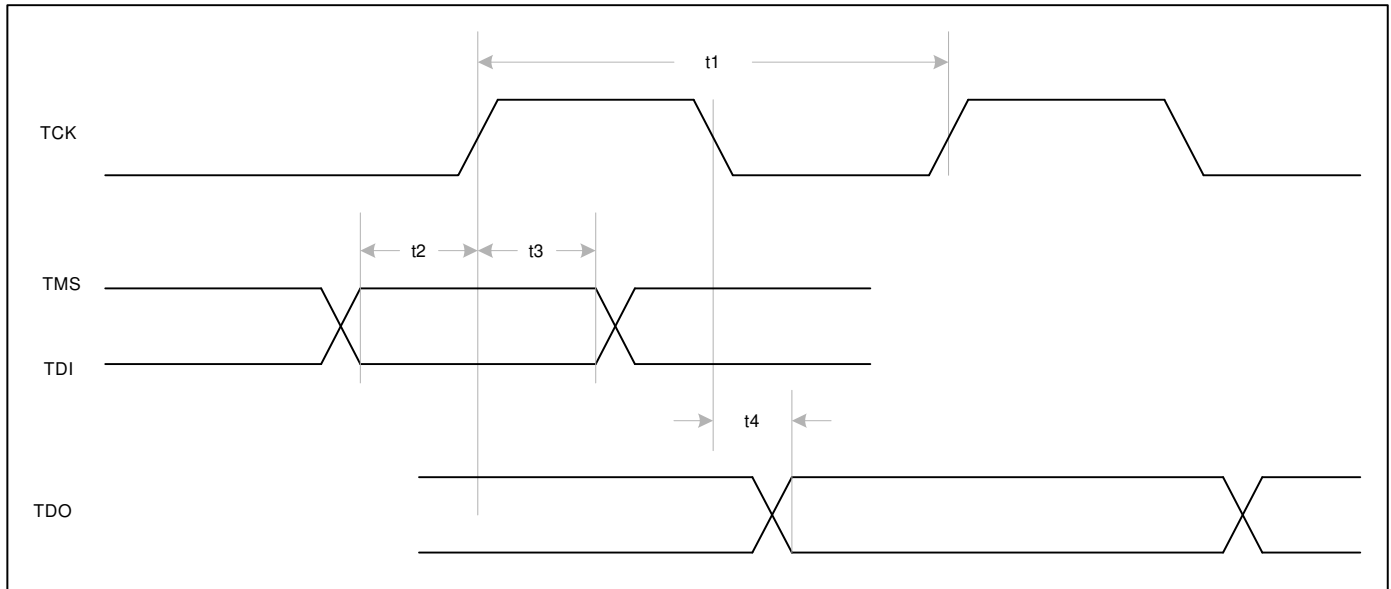

Figure-29 JTAG Interface Timing

PARALLEL HOST INTERFACE TIMING CHARACTERISTICS

INTEL MODE READ TIMING CHARACTERISTICS

Symbol	Parameter	Min	Typ	Max	Unit	Comments
t1	Active \overline{RD} Pulse Width	90			ns	(1)
t2	Active \overline{CS} to Active \overline{RD} Setup Time	0			ns	
t3	Inactive \overline{RD} to Inactive \overline{CS} Hold Time	0			ns	
t4	Valid Address to Inactive ALE Setup Time (in Multiplexed Mode)	5			ns	
t5	Invalid \overline{RD} to Address Hold Time (in Non-Multiplexed Mode)	0			ns	
t6	Active \overline{RD} to Data Output Enable Time	7.5		15	ns	
t7	Inactive \overline{RD} to Data High-Z Delay Time	7.5		15	ns	
t8	Active \overline{CS} to RDY delay time	6		12	ns	
t9	Inactive \overline{CS} to RDY High-Z Delay Time	6		12	ns	
t10	Inactive \overline{RD} to Inactive \overline{INT} Delay Time			20	ns	
t11	Address Latch Enable Pulse Width (in Multiplexed Mode)	10			ns	
t12	Address Latch Enable to \overline{RD} Setup Time (in Multiplexed Mode)	0			ns	
t13	Address Setup time to Valid Data Time (in Non-Multiplexed Mode)	18		32	ns	
t14	Inactive \overline{RD} to Active RDY Delay Time	10		15	ns	
t15	Active \overline{RD} to Active RDY Delay Time	30		85	ns	
t16	Inactive ALE to Address Hold Time (in Multiplexed Mode)	5			ns	

¹ The t1 is determined by the start time of the valid data when the RDY signal is not used.

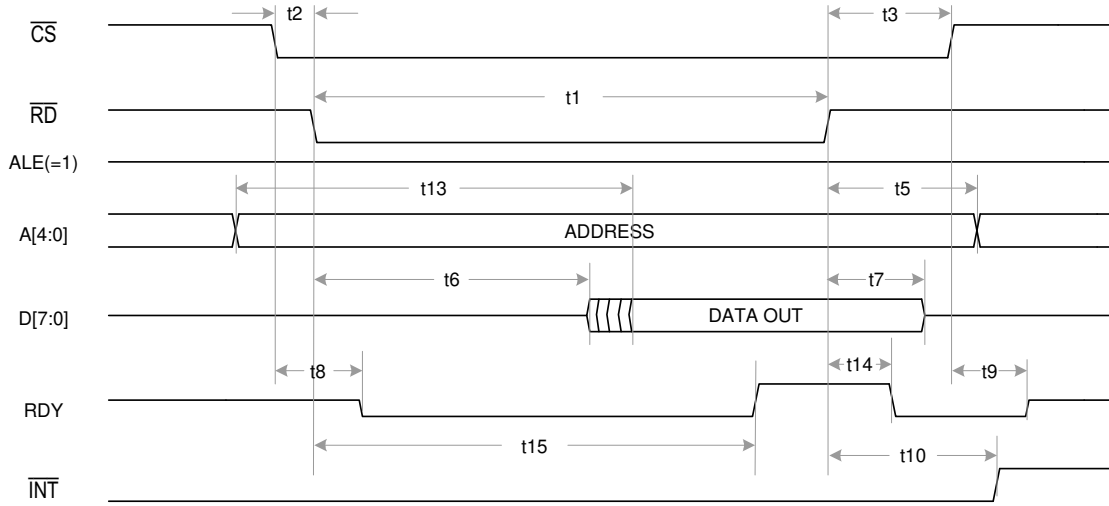

Figure-30 Non-Multiplexed Intel Mode Read Timing

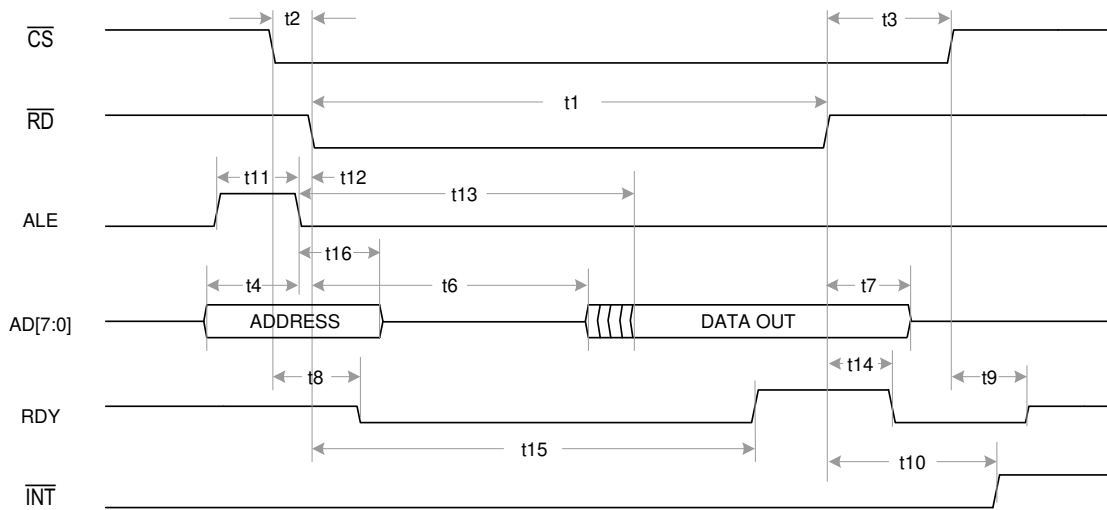

Figure-31 Multiplexed Intel Mode Read Timing

INTEL MODE WRITE TIMING CHARACTERISTICS

Symbol	Parameter	Min	Typ	Max	Unit	Comments
t1	Active \overline{WR} Pulse Width	90			ns	(1)
t2	Active \overline{CS} to Active \overline{WR} Setup Time	0			ns	
t3	Inactive \overline{WR} to Inactive \overline{CS} Hold Time	0			ns	
t4	Valid Address to Latch Enable Setup Time (in Multiplexed Mode)	5			ns	
t5	Invalid \overline{WR} to Address Hold Time (in Non-Multiplexed Mode)	2			ns	
t6	Valid Data to Inactive \overline{WR} Setup Time	5			ns	
t7	Inactive \overline{WR} to Data Hold Time	10			ns	
t8	Active \overline{CS} to Inactive RDY Delay Time	6		12	ns	
t9	Active \overline{WR} to Active RDY Delay Time	30		85	ns	
t10	Inactive \overline{WR} to Inactive RDY Delay Time	10		15	ns	
t11	Invalid \overline{CS} to RDY High-Z Delay Time	6		12	ns	
t12	Address Latch Enable Pulse Width (in Multiplexed Mode)	10			ns	
t13	Inactive ALE to \overline{WR} Setup Time (in Multiplexed Mode)	0			ns	
t14	Inactive ALE to Address hold time (in Multiplexed Mode)	5			ns	
t15	Address setup time to Inactive \overline{WR} time (in Non-Multiplexed Mode)	5			ns	

¹ The t1 can be 15 ns when RDY signal is not used.

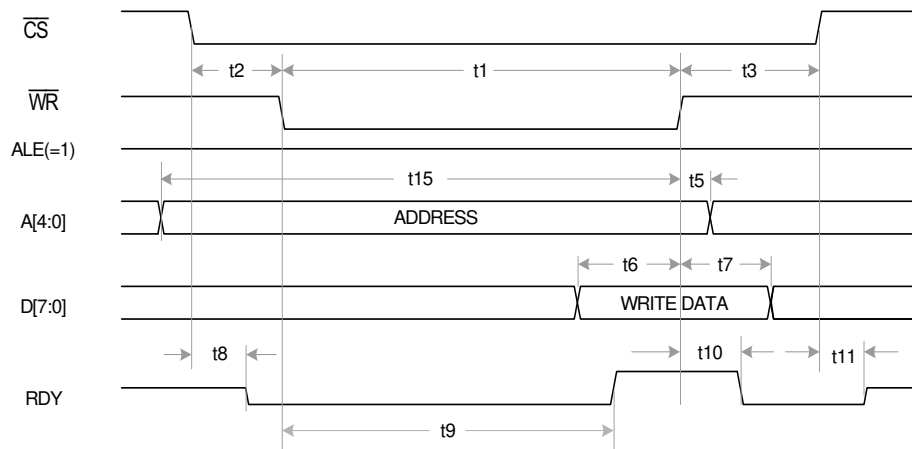

Figure-32 Non-Multiplexed Intel Mode Write Timing

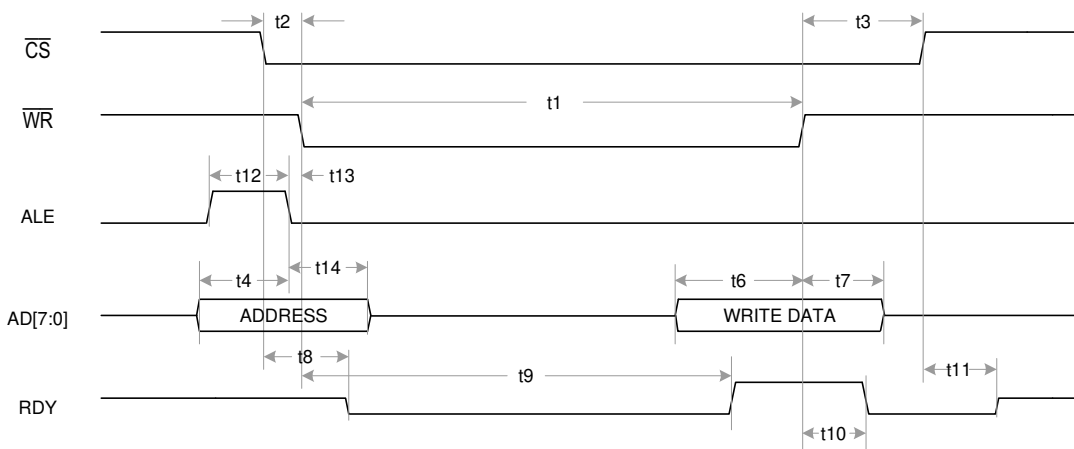

Figure-33 Multiplexed Intel Mode Write Timing

MOTOROLA MODE READ TIMING CHARACTERISTICS

Symbol	Parameter	Min	Typ	Max	Unit	Comments
t1	Active \overline{DS} Pulse Width	90			ns	(1)
t2	Active \overline{CS} to Active \overline{DS} Setup Time	0			ns	
t3	Inactive \overline{DS} to Inactive \overline{CS} Hold Time	0			ns	
t4	Valid R/\overline{W} to Active \overline{DS} Setup Time	0			ns	
t5	Inactive \overline{DS} to R/\overline{W} Hold Time	0.5			ns	
t6	Valid Address to Active \overline{DS} Setup Time (in Non-Multiplexed Mode)	5			ns	
t7	Active \overline{DS} to Address Hold Time (in Non-Multiplexed Mode)	10			ns	
t8	Active \overline{DS} to Data Valid Delay Time (in Non-Multiplexed Mode)	20		35	ns	
t9	Active \overline{DS} to Data Output Enable Time	7.5		15	ns	
t10	Inactive \overline{DS} to Data High-Z Delay Time	7.5		15	ns	
t11	Active \overline{DS} to Active \overline{ACK} Delay Time	30		85	ns	
t12	Inactive \overline{DS} to Inactive \overline{ACK} Delay Time	10		15	ns	
t13	Inactive \overline{DS} to Invalid \overline{INT} Delay Time			20	ns	
t14	Active \overline{AS} to Active \overline{DS} Setup Time (in Multiplexed Mode)	5			ns	

¹ The t1 is determined by the start time of the valid data when the ACK signal is not used.

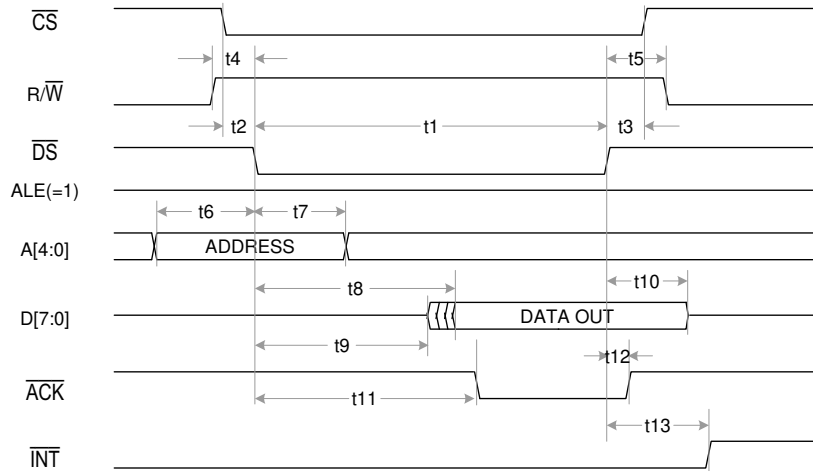

Figure-34 Non-Multiplexed Motorola Mode Read Timing

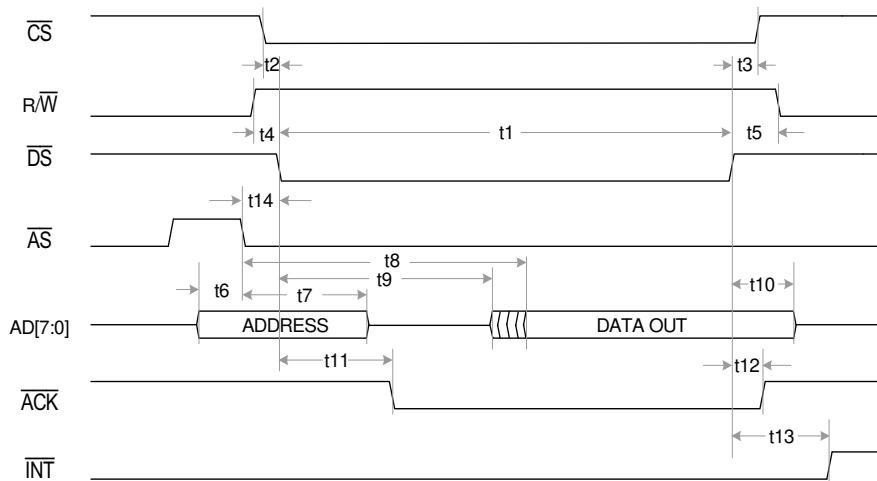

Figure-35 Multiplexed Motorola Mode Read Timing

MOTOROLA MODE WRITE TIMING CHARACTERISTICS

Symbol	Parameter	Min	Typ	Max	Unit	Comments
t1	Active \overline{DS} Pulse Width	90			ns	(1)
t2	Active \overline{CS} to Active \overline{DS} Setup Time	0			ns	
t3	Inactive \overline{DS} to Inactive \overline{CS} Hold Time	0			ns	
t4	Valid R/\overline{W} to Active \overline{DS} Setup Time	10			ns	
t5	Inactive \overline{DS} to R/\overline{W} Hold Time	0			ns	
t6	Valid Address to Active \overline{DS} Setup Time (in Non-Multiplexed Mode)	10			ns	
t7	Valid \overline{DS} to Address Hold Time (in Non-Multiplexed Mode)	10			ns	
t8	Valid Data to Inactive \overline{DS} Setup Time	5			ns	
t9	Inactive \overline{DS} to Data Hold Time	10			ns	
t10	Active \overline{DS} to Active \overline{ACK} Delay Time	30		85	ns	
t11	Inactive \overline{DS} to Inactive \overline{ACK} Delay Time	10		15	ns	
t12	Active \overline{AS} to Active \overline{DS} (in Multiplexed Mode)	0			ns	
t13	Inactive \overline{DS} to Inactive \overline{AS} Hold Time (in Multiplexed Mode)	15			ns	

¹. The t1 can be 15ns when the ACK signal is not used.

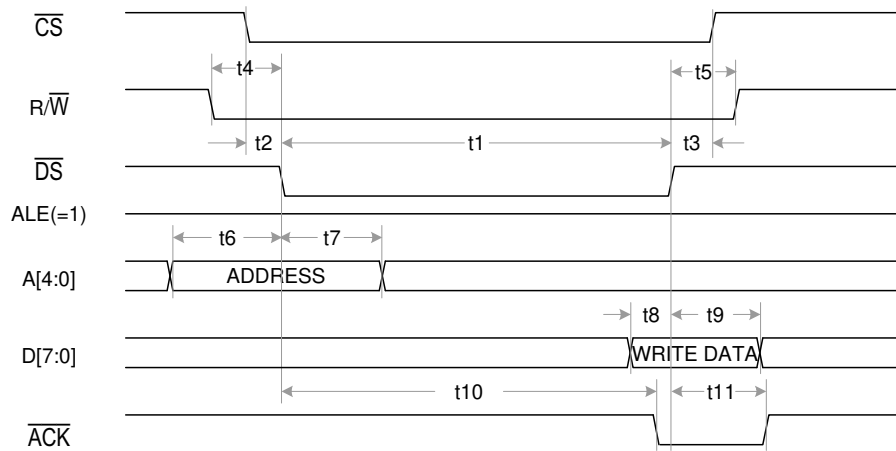

Figure-36 Non-Multiplexed Motorola Mode Write Timing

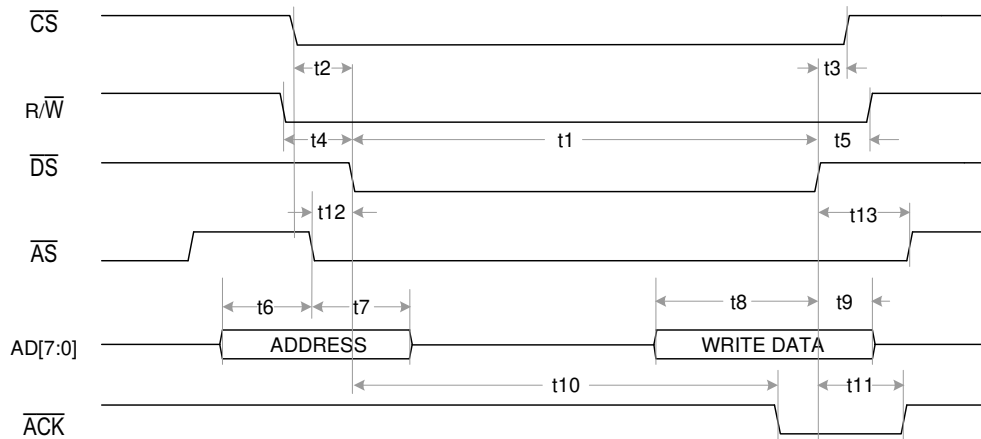

Figure-37 Multiplexed Motorola Mode Writing Timing

SERIAL HOST INTERFACE TIMING CHARACTERISTICS

Symbol	Parameter	Min	Typ	Max	Unit	Comments
t1	SCLK High Time	25			ns	
t2	SCLK Low Time	25			ns	
t3	Active \overline{CS} to SCLK Setup Time	10			ns	
t4	Last SCLK Hold Time to Inactive \overline{CS} Time	50			ns	
t5	\overline{CS} Idle Time	50			ns	
t6	SDI to SCLK Setup Time	5			ns	
t7	SCLK to SDI Hold Time	5			ns	
t8	Rise/Fall Time (any pin)			100	ns	
t9	SCLK Rise and Fall Time			50	ns	
t10	SCLK to SDO Valid Delay Time		25	35	ns	Load = 50 pF
t11	SCLK Falling Edge to SDO High-Z Hold Time (CLKE = 0) or \overline{CS} Rising Edge to SDO High-Z Hold Time (CLKE = 1)		100		ns	

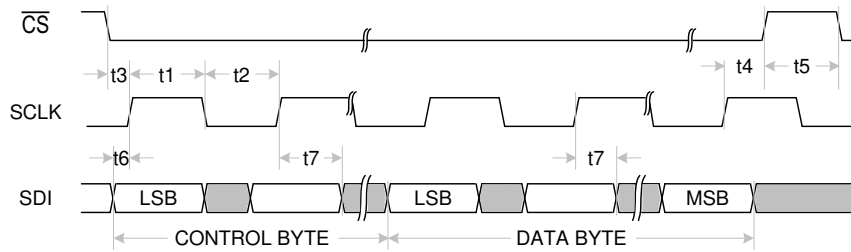

Figure-38 Serial Interface Write Timing

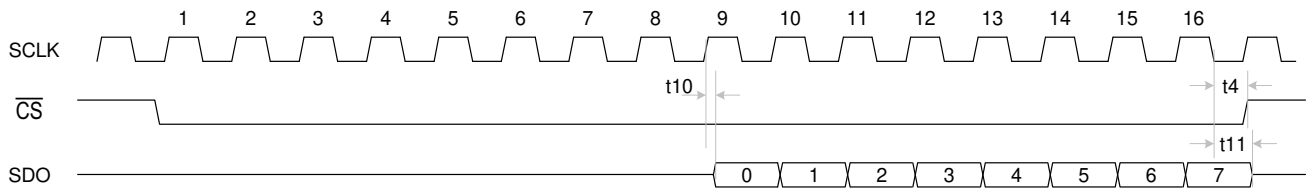

Figure-39 Serial Interface Read Timing with CLKE = 0

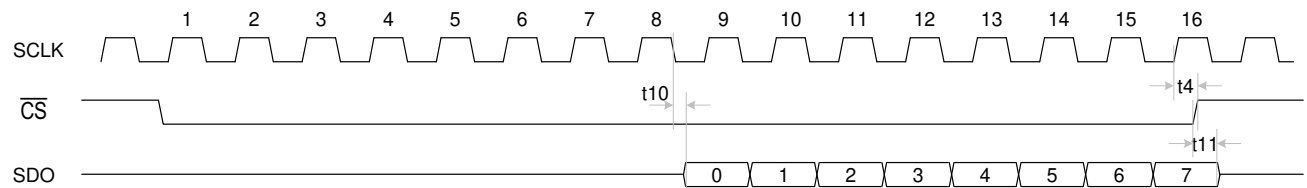
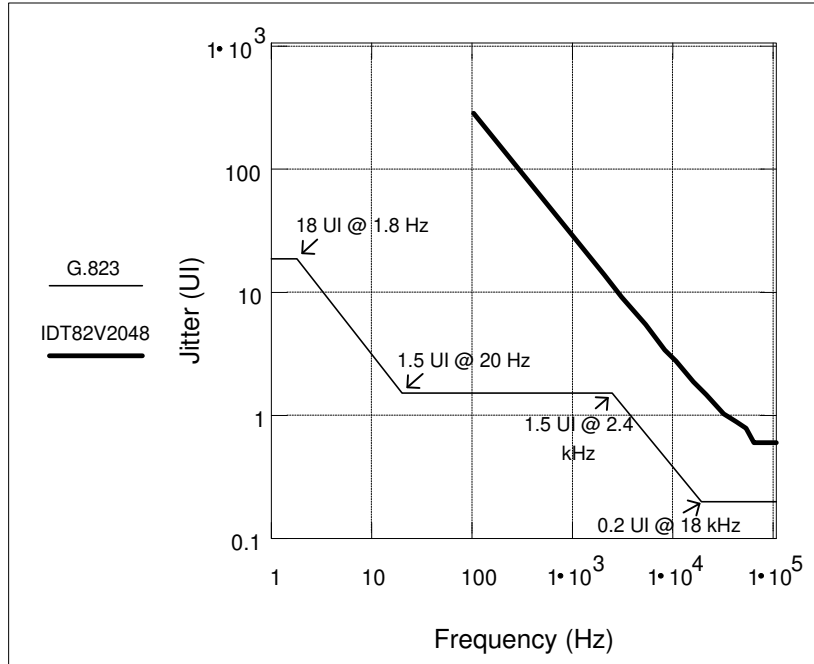

Figure-40 Serial Interface Read Timing with CLKE = 1

JITTER TOLERANCE PERFORMANCE

E1 JITTER TOLERANCE PERFORMANCE



Test condition: PRBS 2¹⁵-1; Line code rule HDB3 is used.

Figure-41 E1 Jitter Tolerance Performance

T1 JITTER TOLERANCE PERFORMANCE

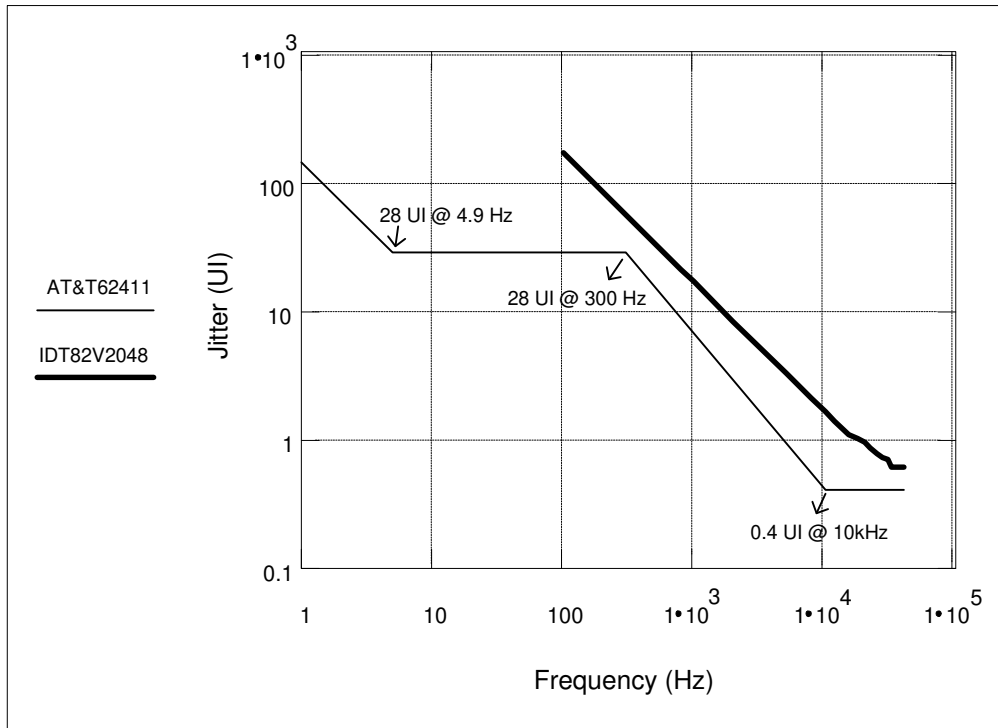

Test condition: QRSS; Line code rule B8ZS is used.

Figure-42 T1 Jitter Tolerance Performance

JITTER TRANSFER PERFORMANCE

E1 JITTER TRANSFER PERFORMANCE

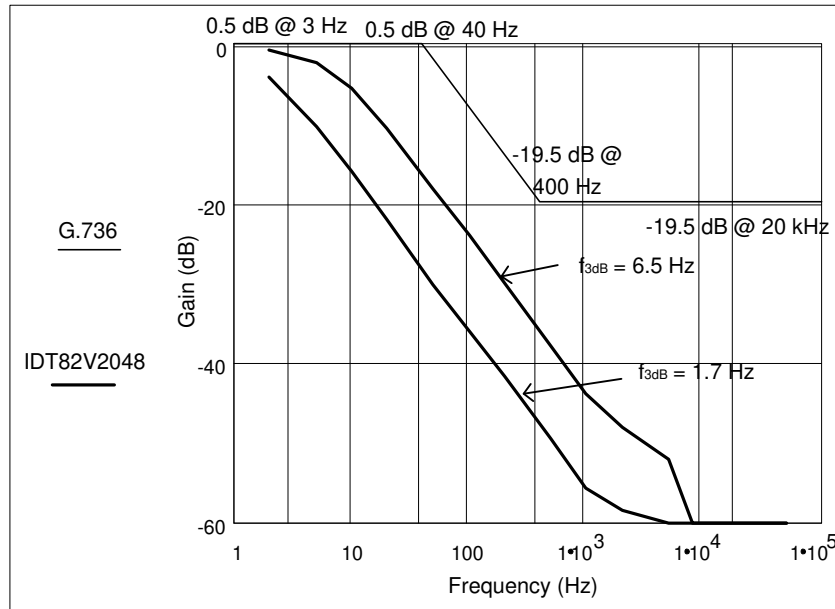

Test condition: PRBS 2¹⁵-1; Line code rule HDB3 is used.

Figure-43 E1 Jitter Transfer Performance

T1 JITTER TRANSFER PERFORMANCE

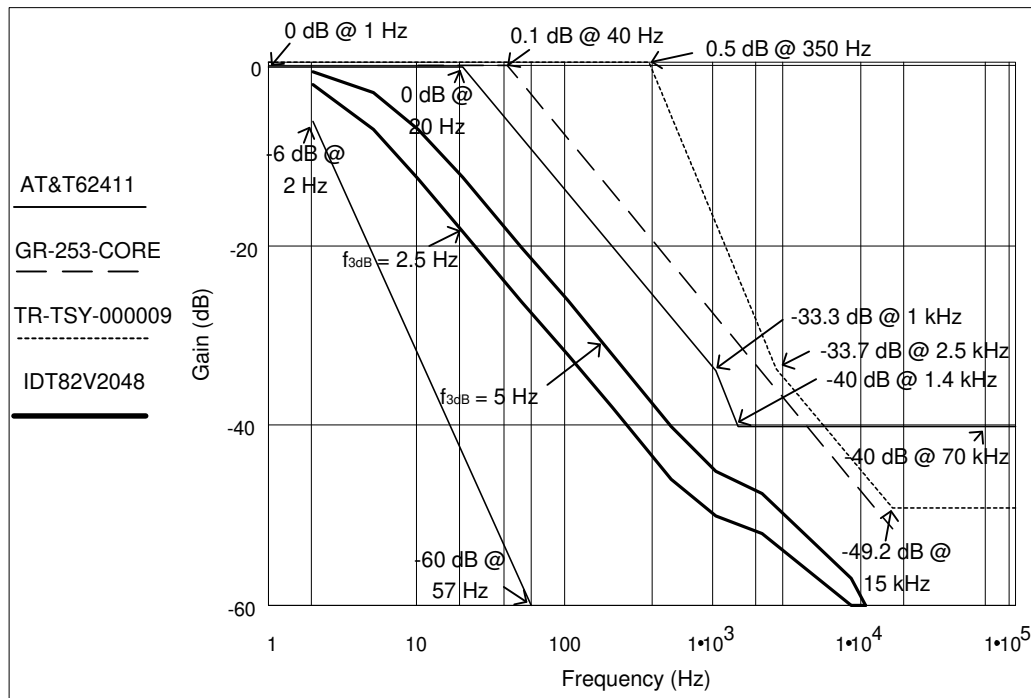

Test condition: QRSS; Line code rule B8ZS is used.

Figure-44 T1 Jitter Transfer Performance

ORDERING INFORMATION

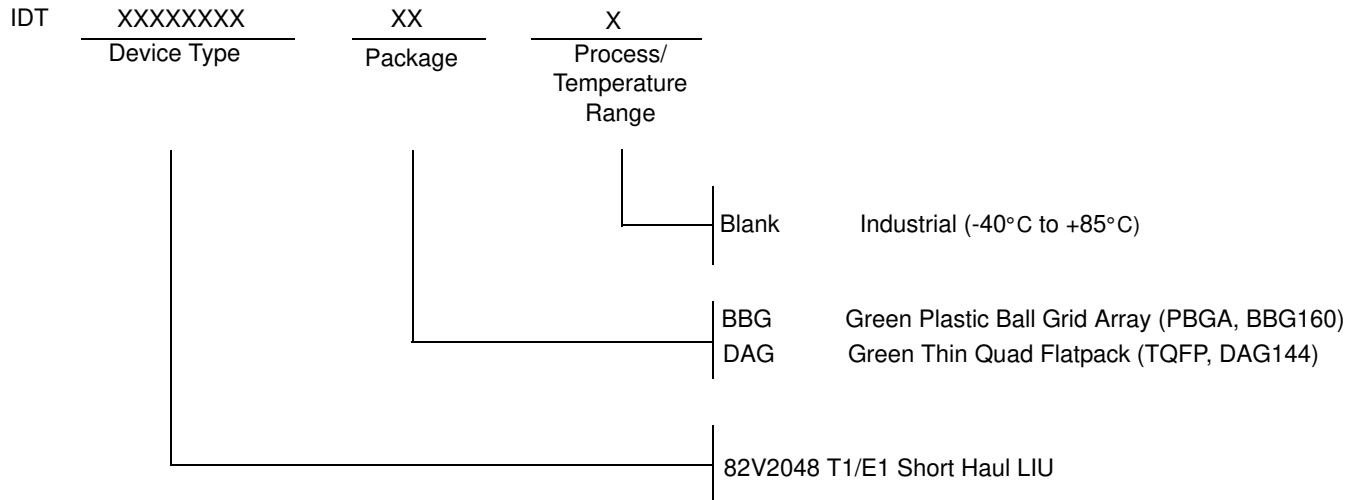

DATASHEET DOCUMENT HISTORY

11/04/2001	pgs. 2, 3, 11, 19
11/20/2001	pgs. 5, 6, 12, 14, 18, 19, 27, 30, 36, 44, 45, 46, 58
11/28/2001	pgs. 5, 27, 30, 37
11/29/2001	pgs. 5, 12
12/05/2001	pgs. 9
12/24/2001	pgs. 44, 45
01/05/2002	pgs. 23, 36
01/24/2002	pgs. 2, 3, 10, 16, 45, 46
02/21/2002	pgs. 15, 19, 47
03/25/2002	pgs. 1, 2, 60
04/17/2002	pgs. 20
05/07/2002	pgs. 15, 51, 52, 55
08/27/2002	pgs. 23, 37
01/15/2003	pgs. 1, 61
12/09/2003	pgs. 23
09/02/2004	pgs. 11, 15, 19, 45, 47, 48
04/12/2005	pgs. 1, 5, 6 to 11, 13 to 15, 19, 20, 32, 47, 48, 50, 54 to 58, 61
07/22/2005	pgs. 10, 11, 18, 19, 45, 46, 61
03/18/2009	pg. 19
09/11/2009	pg. 46
01/21/2010	pg. 9
04/26/2010	pgs. 15, 16, 17, 18
07/01/2010	pgs. 17
11/14/12	pg. 62

IMPORTANT NOTICE AND DISCLAIMER

RENESAS ELECTRONICS CORPORATION AND ITS SUBSIDIARIES (“RENESAS”) PROVIDES TECHNICAL SPECIFICATIONS AND RELIABILITY DATA (INCLUDING DATASHEETS), DESIGN RESOURCES (INCLUDING REFERENCE DESIGNS), APPLICATION OR OTHER DESIGN ADVICE, WEB TOOLS, SAFETY INFORMATION, AND OTHER RESOURCES “AS IS” AND WITH ALL FAULTS, AND DISCLAIMS ALL WARRANTIES, EXPRESS OR IMPLIED, INCLUDING, WITHOUT LIMITATION, ANY IMPLIED WARRANTIES OF MERCHANTABILITY, FITNESS FOR A PARTICULAR PURPOSE, OR NON-INFRINGEMENT OF THIRD PARTY INTELLECTUAL PROPERTY RIGHTS.

These resources are intended for developers skilled in the art designing with Renesas products. You are solely responsible for (1) selecting the appropriate products for your application, (2) designing, validating, and testing your application, and (3) ensuring your application meets applicable standards, and any other safety, security, or other requirements. These resources are subject to change without notice. Renesas grants you permission to use these resources only for development of an application that uses Renesas products. Other reproduction or use of these resources is strictly prohibited. No license is granted to any other Renesas intellectual property or to any third party intellectual property. Renesas disclaims responsibility for, and you will fully indemnify Renesas and its representatives against, any claims, damages, costs, losses, or liabilities arising out of your use of these resources. Renesas' products are provided only subject to Renesas' Terms and Conditions of Sale or other applicable terms agreed to in writing. No use of any Renesas resources expands or otherwise alters any applicable warranties or warranty disclaimers for these products.

(Disclaimer Rev.1.0 Mar 2020)

Corporate Headquarters

TOYOSU FORESIA, 3-2-24 Toyosu,
Koto-ku, Tokyo 135-0061, Japan
www.renesas.com

Contact Information

For further information on a product, technology, the most up-to-date version of a document, or your nearest sales office, please visit:
www.renesas.com/contact/

Trademarks

Renesas and the Renesas logo are trademarks of Renesas Electronics Corporation. All trademarks and registered trademarks are the property of their respective owners.