

REVISIONS				
P	LTN	DESCRIPTION	DATE	APVD
A		RELEASED PER ECO-19-013357	29AUG2019	CJV JW
B		REVISED PER ECO-19-014774	26SEP2019	CJV JW
C		ADDED 2-2331813-1/2	30NOV2022	RW DZ

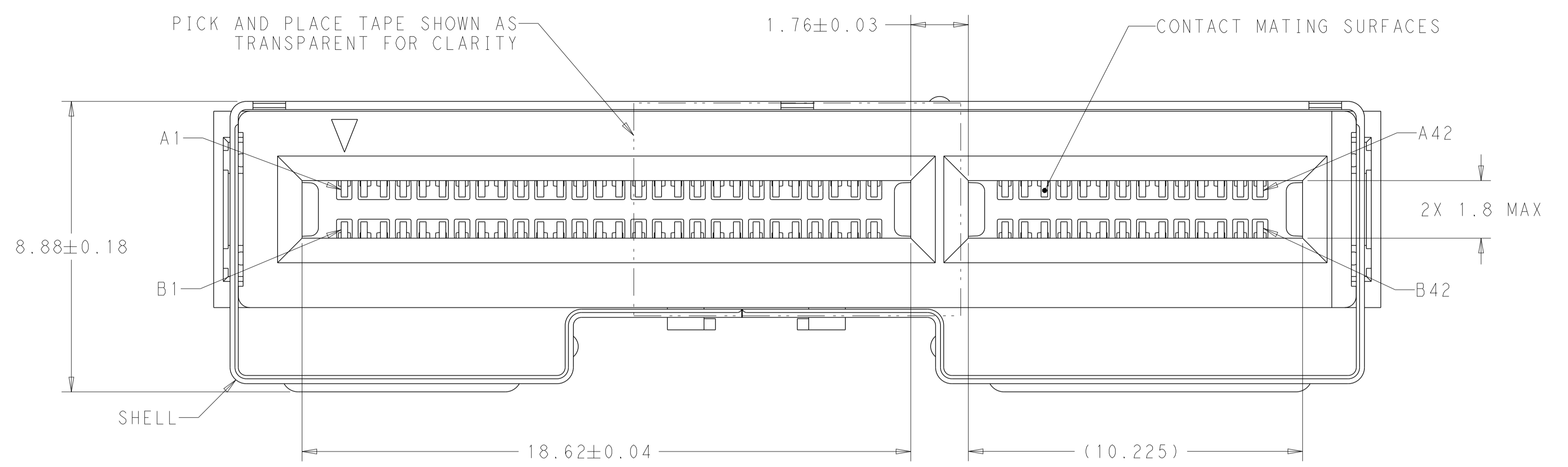

- 1 HOUSING AND CONTACT OVERMOLDS - LCP, UL94V-0, BLACK. SHELL, CONTACTS, HOLD DOWNS - COPPER ALLOY. PICK AND PLACE TAPE - POLYIMIDE FILM.
- 2 CONTACTS - GOLD PLATE ON MATING SURFACES, TIN PLATE ON SOLDER FEET. HOLD DOWNS - TIN PLATE. SHELL - TIN PLATE.
- 3 DATUMS AND BASIC DIMENSIONS ESTABLISHED BY CUSTOMER.
4. MINIMUM HOST PCB THICKNESS: 1.5.
- 5 SEE MSA SPECIFICATION FOR ADDITIONAL PADDLE CARD LAYOUTS COMPATIBLE WITH THIS RECEPTACLE AND FOR OPTIONAL SPLIT CONTACT PAD LAYOUTS FOR THE PADDLE CARD. SPECIFICATION PINOUT MAY ALSO DESIGNATE PAD SEQUENCE DIFFERENT FROM ILLUSTRATION.
- 6 POSITIONS DESIGNATED AS "SIGNAL" ARE REQUIRED LOCATIONS FOR HIGH SPEED DIFFERENTIAL PAIR SIGNALING. THESE LOCATIONS MAY ALSO BE USED FOR SUPPORTING SIDEBAND SIGNALS OR OTHER UTILITY PURPOSES. POSITIONS DESIGNATED AS "GROUND" ARE REQUIRED WHEN SUPPORTING HIGH SPEED DIFFERENTIAL SIGNALS. THESE LOCATIONS MAY ALSO BE USED FOR SIDEBAND SIGNALS OR OTHER UTILITY PURPOSES.
- 7 RECOMMENDED COMPONENT AND TRACE KEEP OUT AREA. EACH EDGE 0.15 MIN FROM EDGE OF HOLE.
- 8 TAPE AND REEL PACKAGED FOR PICK AND PLACE SMT PROCESSING, SEE FIGURE 1. POCKET TAPE WIDTH = 56.

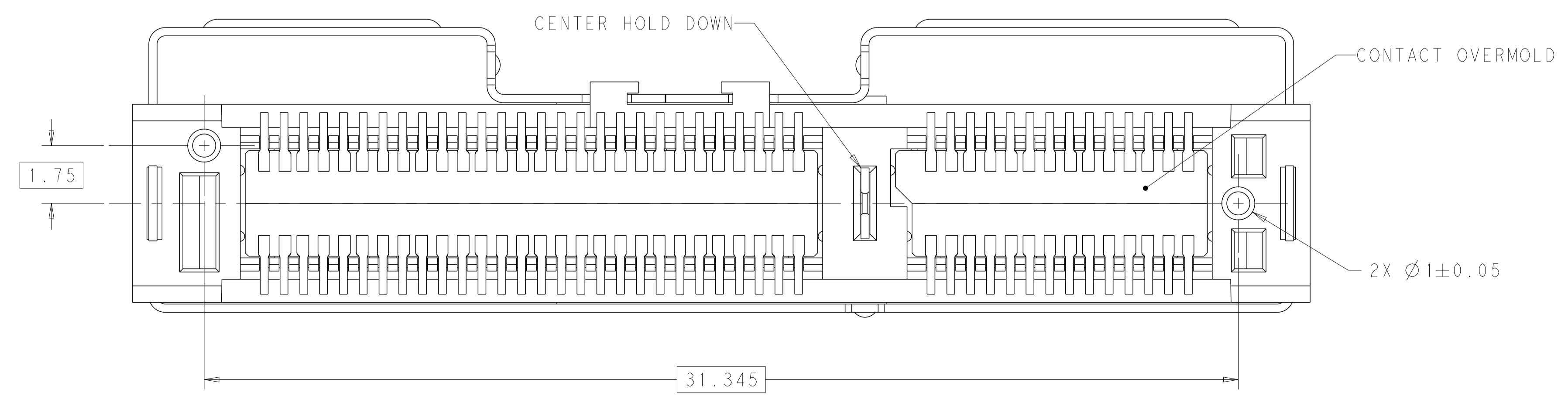
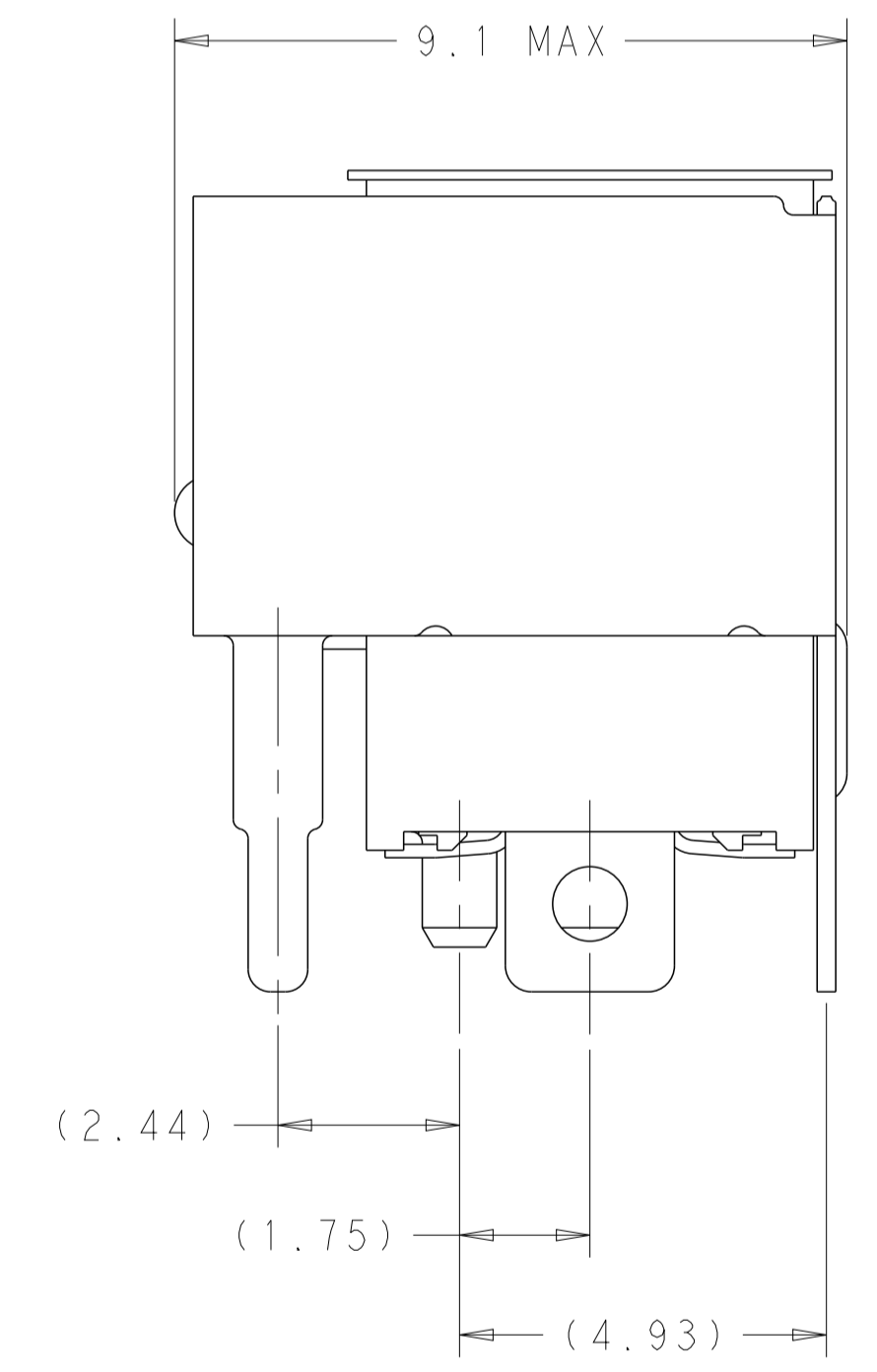
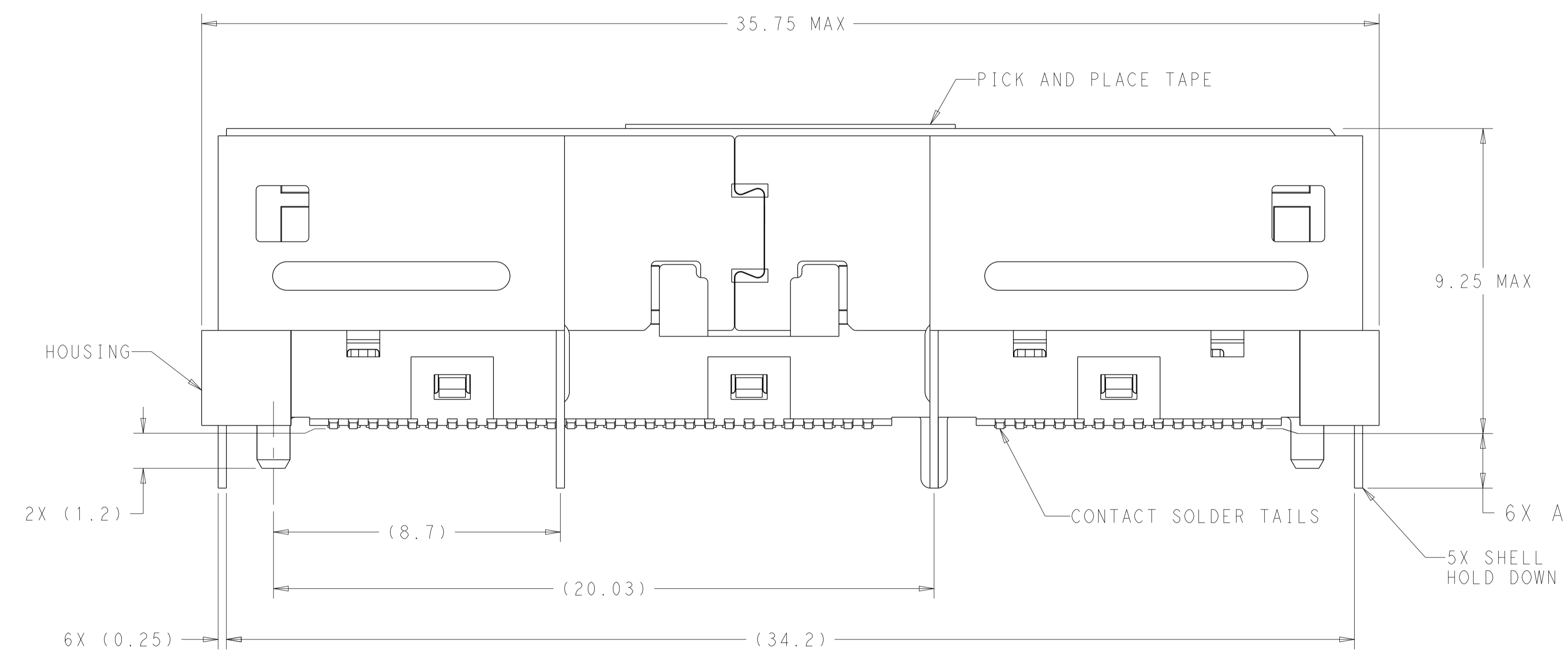

SEE SHEET 4 FOR PART TABLE

THIS DRAWING IS A CONTROLLED DOCUMENT.		OWN: B. MATTHEWS 12MAR2018	TE Connectivity	
		CHK: D. HARMON 12MAR2018		
DIMENSIONS:		APVD: D. HARMON 12MAR2018	NAME: RECEPTACLE ASSEMBLY, VERTICAL, 84 POSITION, SLIVER 2.0	
mm		PRODUCT SPEC: 108-130021	APPLICATION SPEC: -	
0 PLC ±0.5 1 PLC ±0.13 2 PLC ±0.013 3 PLC ±0.001 4 PLC ±0.001 ANGLES ±0.001		SIZE: A1	CAGE CODE: -	DRAWING NO: C=2331813
MATERIAL:		FINISH:	WEIGHT: -	RESTRICTED TO: -
		CUSTOMER DRAWING		SCALE: 1:1 SHEET 1 OF 4 REV: C2

REVISIONS				
P	LTN	DESCRIPTION	DATE	APVD
-	-	SEE SHEET 1	-	-

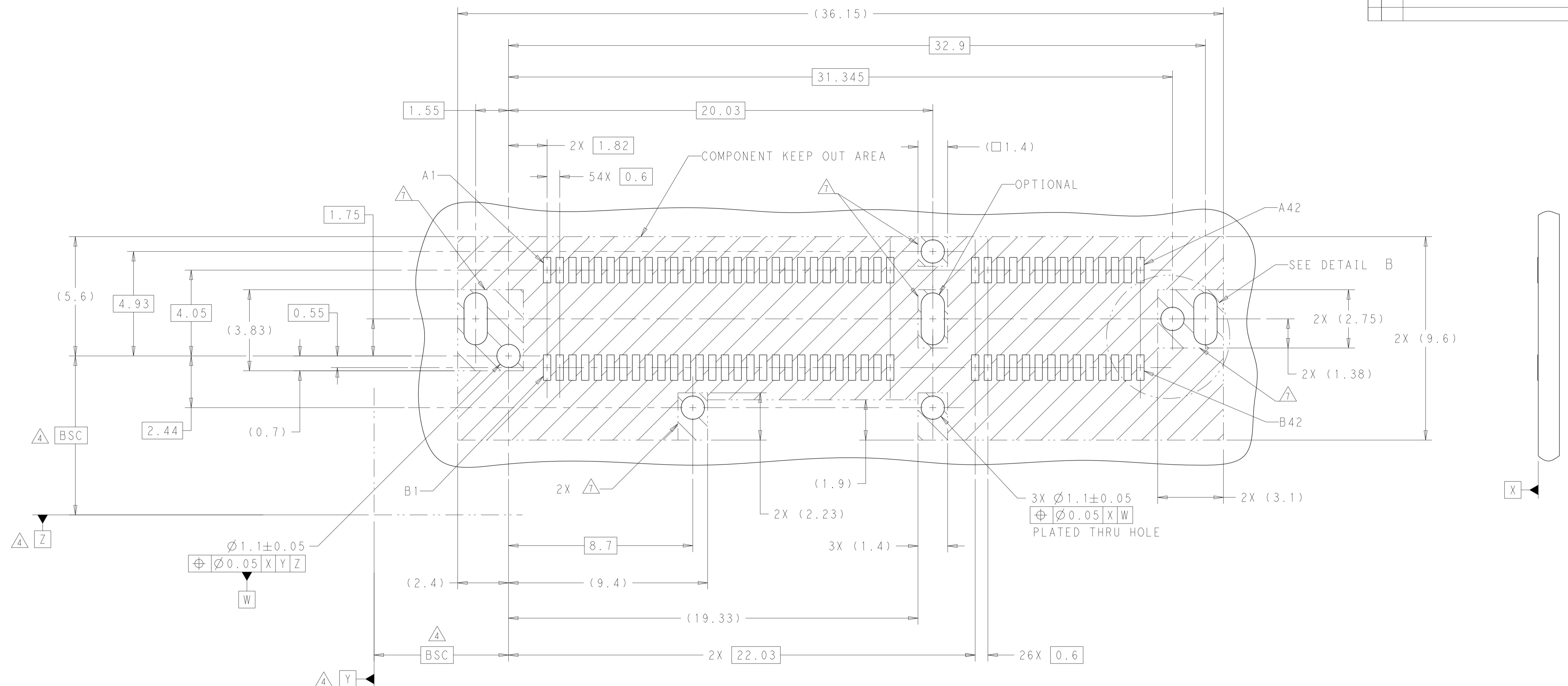

RECOMMENDED PC BOARD LAYOUT

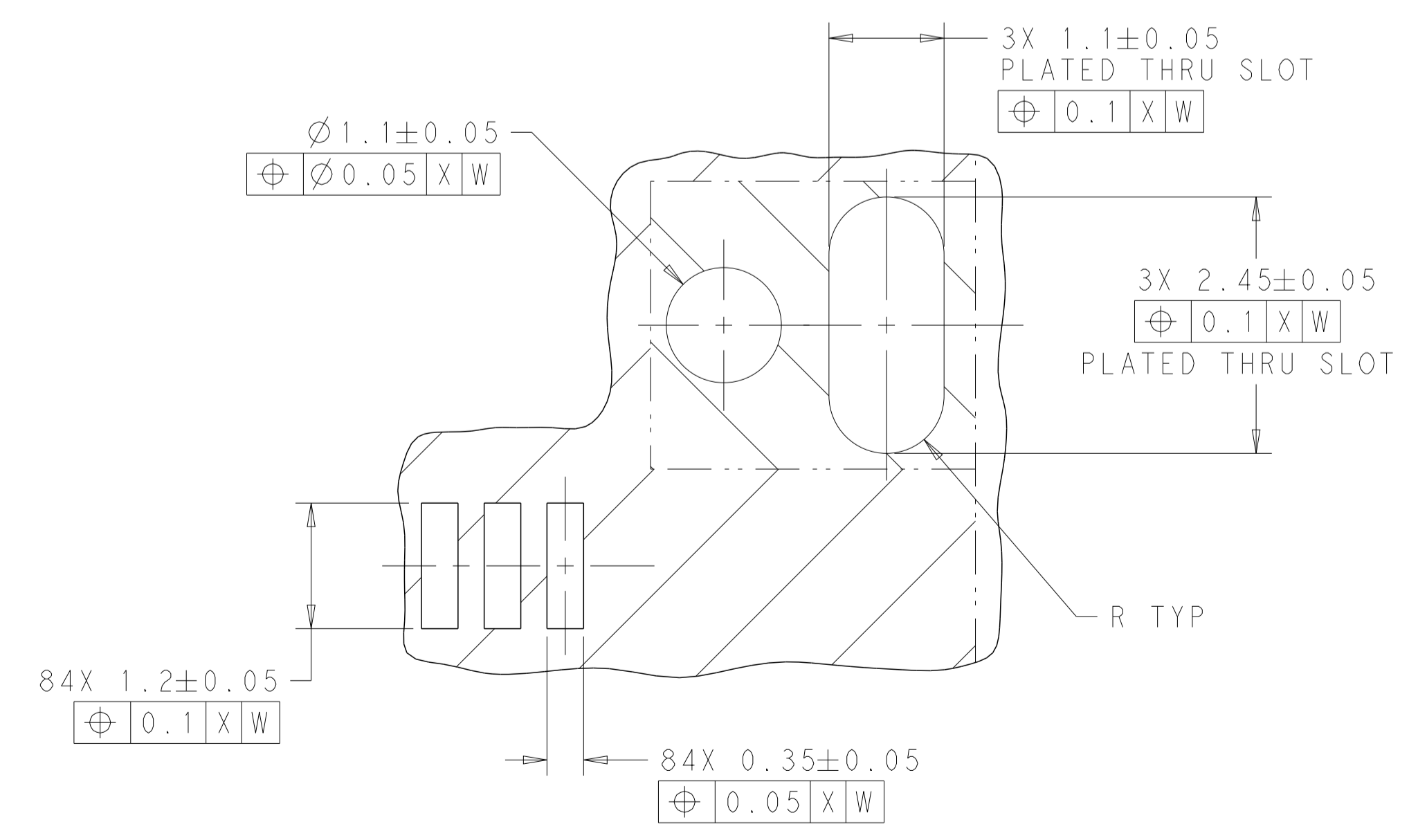

DETAIL B
SCALE 20:1

THIS DRAWING IS A CONTROLLED DOCUMENT.		OWN: B. MATTHEWS 12MAR2018	TE Connectivity
		CHK: D. HARMON 12MAR2018	
DIMENSIONS:		APVD: D. HARMON 12MAR2018	NAME: RECEPTACLE ASSEMBLY, VERTICAL, 84 POSITION, SLIVER 2.0 PRODUCT SPEC: 108-130021 APPLICATION SPEC: 114-130015
0 PLC ±0.5 1 PLC ±0.13 2 PLC ±0.013 3 PLC ±0.001 4 PLC ±0.001 ANGLES ±0.0001 FINISH:		TOLERANCES UNLESS OTHERWISE SPECIFIED: mm	
MATERIAL:		WEIGHT: -	SIZE: A1 CAGE CODE: - DRAWING NO: C=2331813 RESTRICTED TO: -
CUSTOMER DRAWING		SCALE: 1:1	SHEET: 2 OF 4 REV: C2

REVISIONS				
P	LTN	DESCRIPTION	DATE	APVD
-	-	SEE SHEET 1	-	-

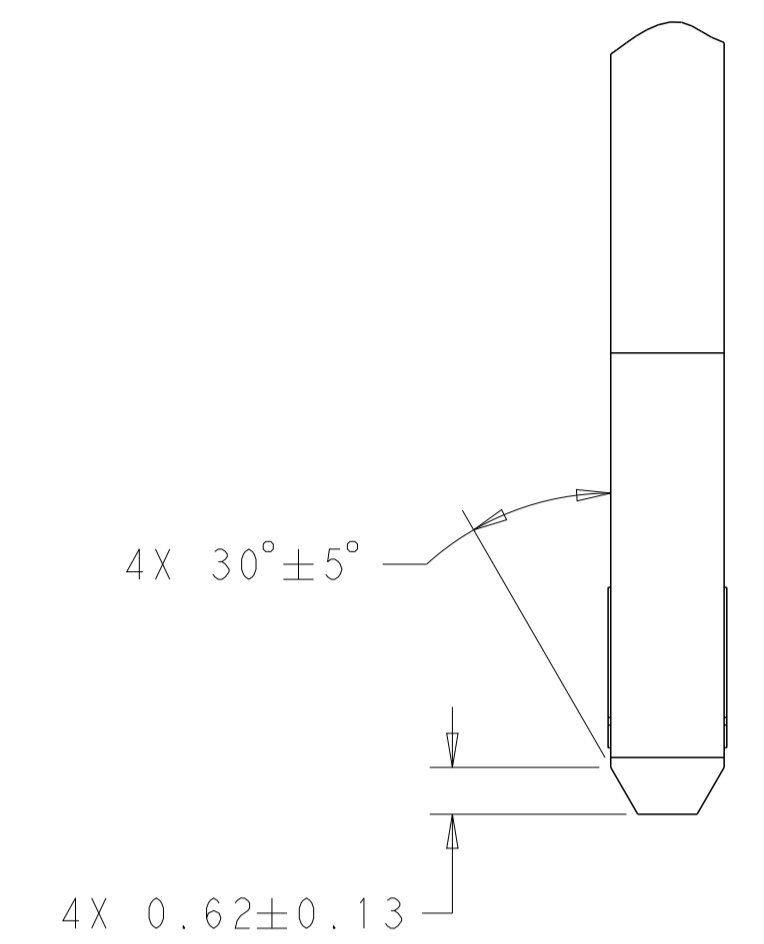
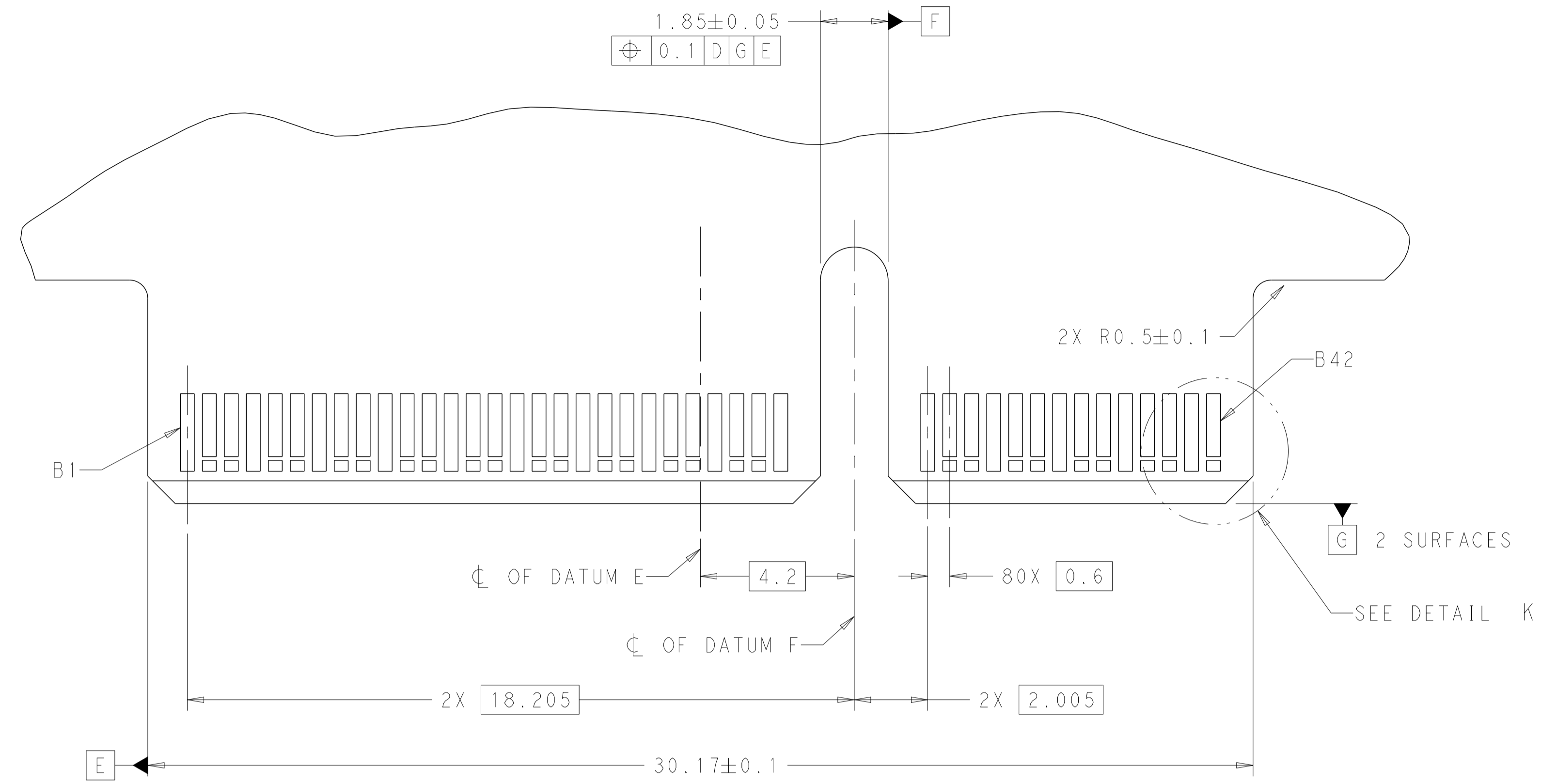

RECOMMENDED PCB OUTLINE DIMENSIONS.
 TOLERANCE VALUES ARE CRITICAL. PLEASE BE SURE TO DESIGNATE
 TOLERANCES TO PCB SUPPLIER TO ENSURE OPTIMIZED FUNCTIONALITY.

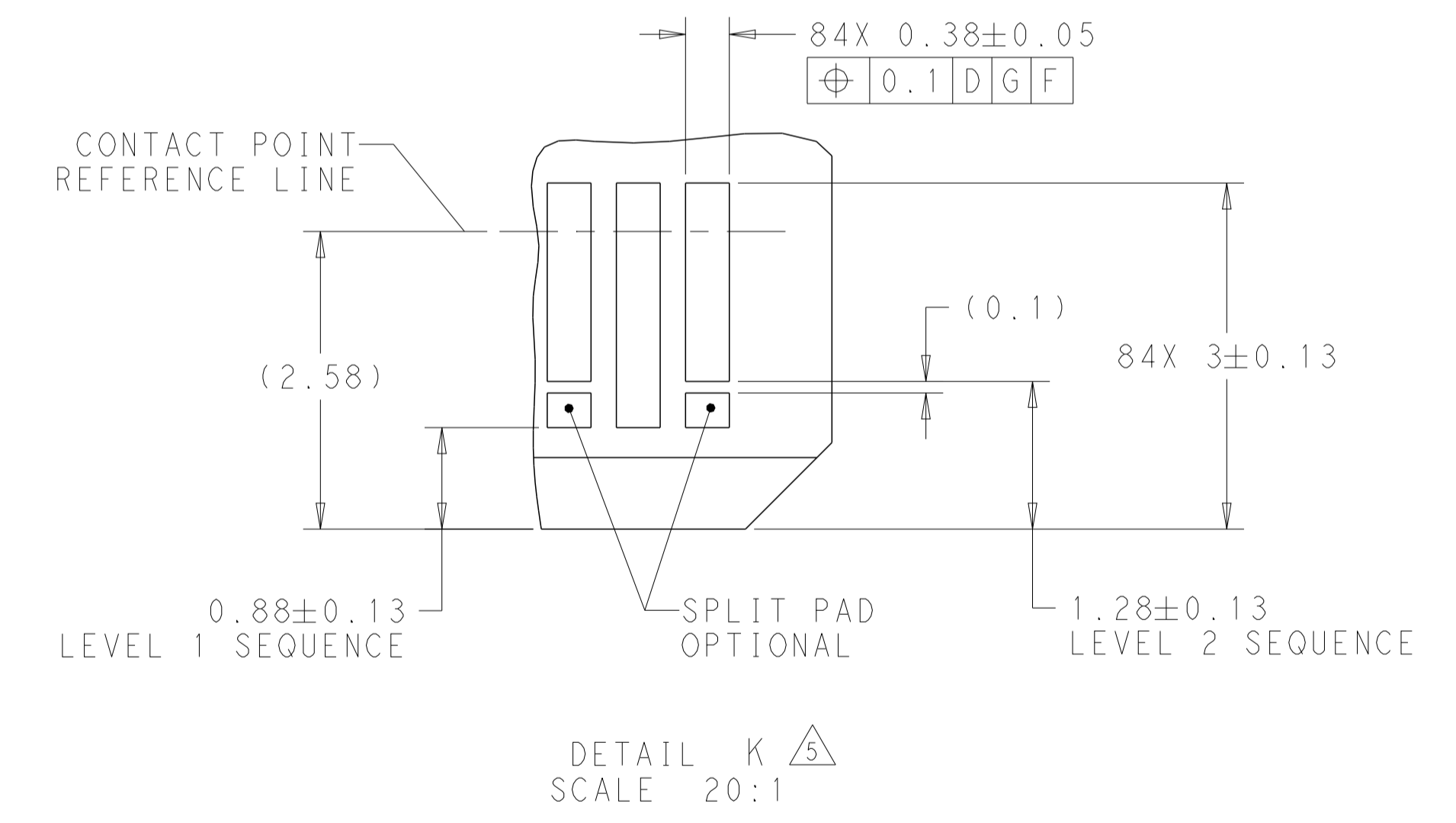
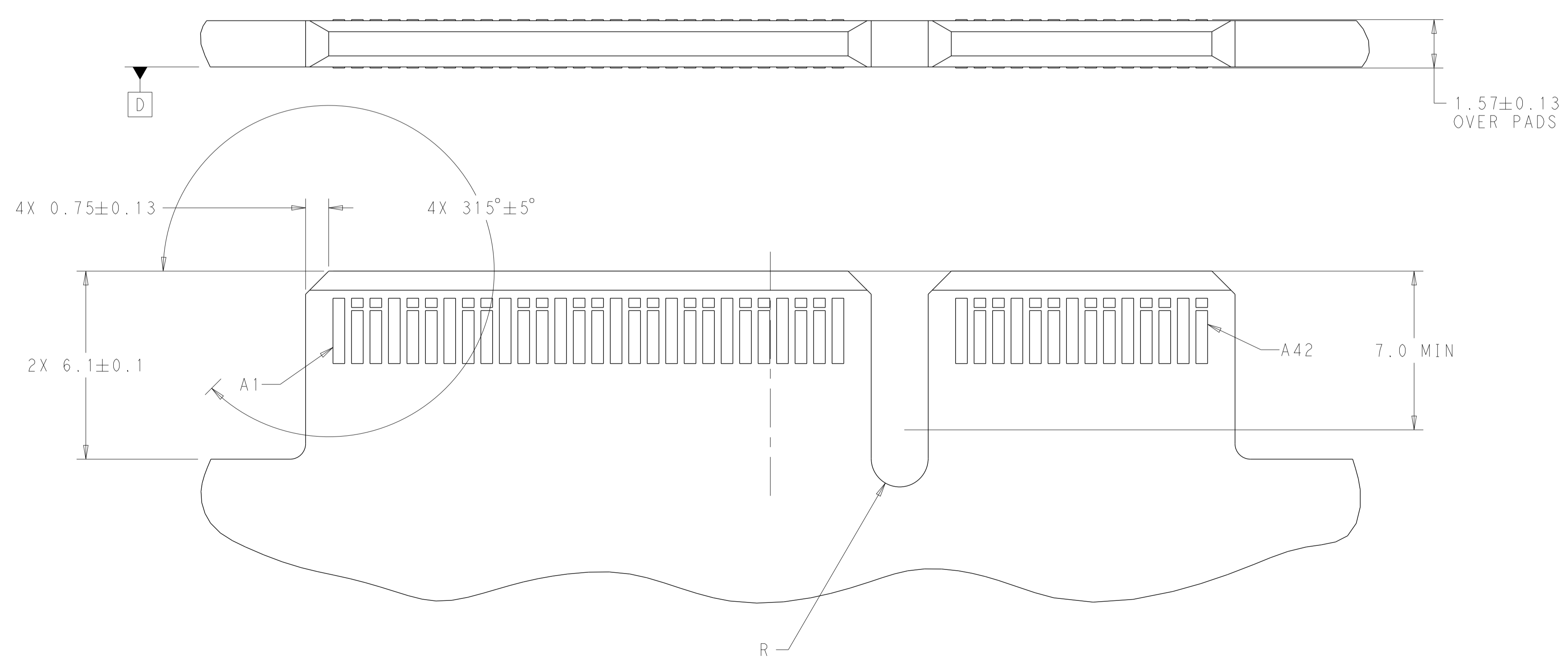

THIS DRAWING IS A CONTROLLED DOCUMENT.		OWN B. MATTHEWS 12MAR2018	TE Connectivity
DIMENSIONS:		CHK D. HARMON 12MAR2018	
mm	TOLERANCES UNLESS OTHERWISE SPECIFIED:	APVD D. HARMON 12MAR2018	NAME RECEPTACLE ASSEMBLY, VERTICAL, 84 POSITION, SLIVER 2.0
0 PLC ±0.5 2 PLC ±0.13 3 PLC ±0.013 4 PLC ±0.0001 ANGLES ±0.0001	FINISH	PRODUCT SPEC 108-130021	SIZE A1
MATERIAL		APPLICATION SPEC 114-130015	CAGE CODE -
		WEIGHT -	DRAWING NO C=2331813
		CUSTOMER DRAWING	SCALE 1:1 SHEET 3 OF 4 REV C2

REVISIONS				
P.	LTN	DESCRIPTION	DATE	APVD
-	-	SEE SHEET 1	-	-

TABLE 1: CONNECTOR CONTACT IDENTIFICATION

CONTACT NUMBER	SIDE A	SIDE B
1	GROUND	GROUND
2	SIGNAL	SIGNAL
3	SIGNAL	SIGNAL
4	GROUND	GROUND
5	SIGNAL	SIGNAL
6	SIGNAL	SIGNAL
7	GROUND	GROUND
8	SIGNAL	SIGNAL
9	SIGNAL	SIGNAL
10	GROUND	GROUND
11	SIGNAL	SIGNAL
12	SIGNAL	SIGNAL
13	GROUND	GROUND
14	SIGNAL	SIGNAL
15	SIGNAL	SIGNAL
16	GROUND	GROUND
17	SIGNAL	SIGNAL
18	SIGNAL	SIGNAL
19	GROUND	GROUND
20	SIGNAL	SIGNAL
21	SIGNAL	SIGNAL
22	GROUND	GROUND
23	SIGNAL	SIGNAL
24	SIGNAL	SIGNAL
25	GROUND	GROUND
26	SIGNAL	SIGNAL
27	SIGNAL	SIGNAL
28	GROUND	GROUND
29	GROUND	GROUND
30	SIGNAL	SIGNAL
31	SIGNAL	SIGNAL
32	GROUND	GROUND
33	SIGNAL	SIGNAL
34	SIGNAL	SIGNAL
35	GROUND	GROUND
36	SIGNAL	SIGNAL
37	SIGNAL	SIGNAL
38	GROUND	GROUND
39	SIGNAL	SIGNAL
40	SIGNAL	SIGNAL
41	GROUND	GROUND
42	GROUND	GROUND

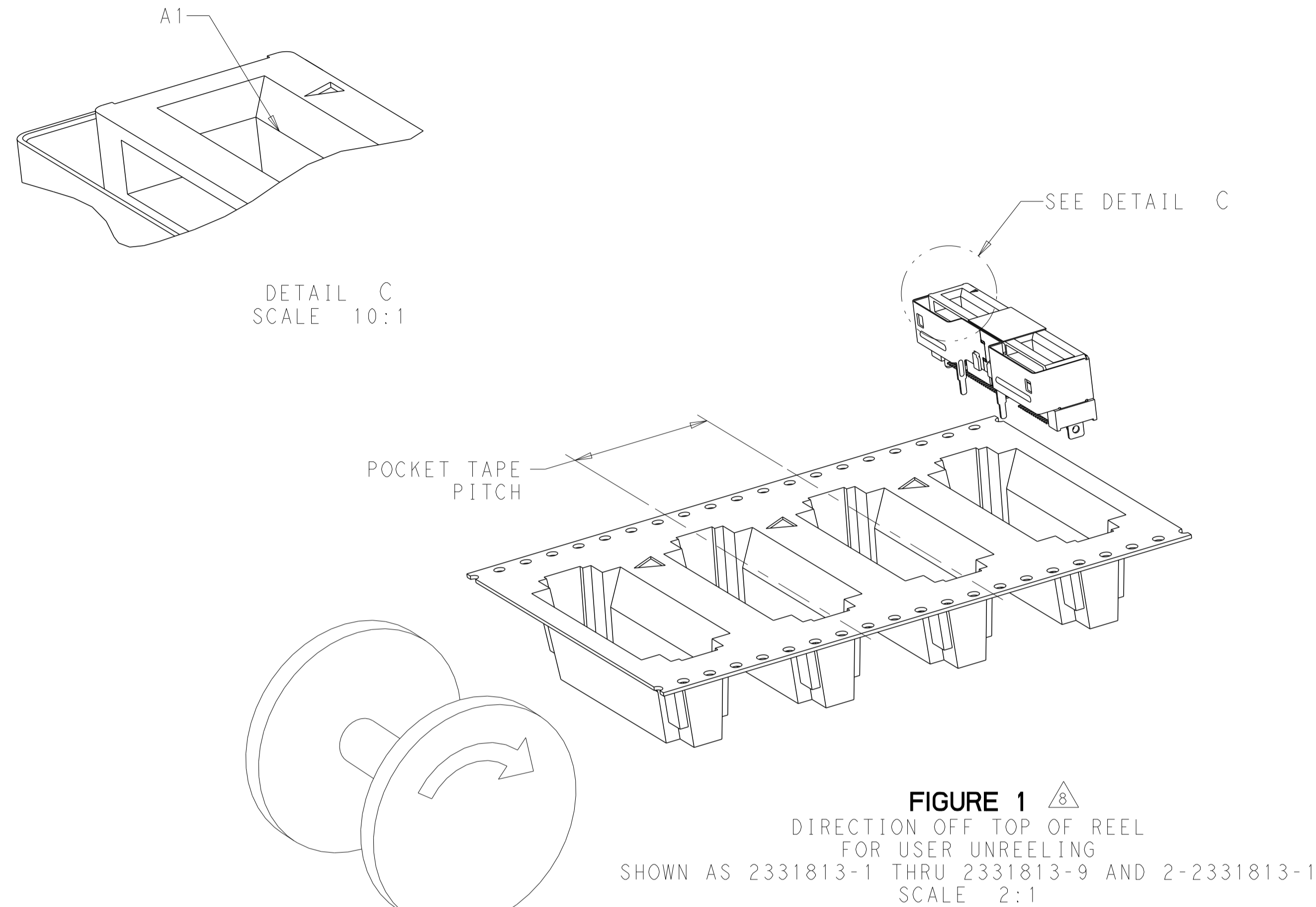

3.0 ^{+0.2} / _{-0.1}	YES	0.76µm Au	20	300	YES	200	2-2331813-2
3.3 ^{+0.2} / _{-0.1}	YES	0.76µm Au	20	300	YES	200	2-2331813-1
1.2±0.2	NO	0.76µm Au	24	250	NO	200	1-2331813-8
		0.38µm Au				100	1-2331813-7
		FLASH Au/PdNi				50	1-2331813-7
1.8 ^{+0.2} / _{-0.1}	NO	0.76µm Au	24	250	NO	200	1-2331813-6
		0.38µm Au				100	1-2331813-5
		FLASH Au/PdNi				50	1-2331813-4
1.8 ^{+0.2} / _{-0.1}	YES	0.76µm Au	24	250	NO	200	1-2331813-3
		0.38µm Au				100	1-2331813-2
		FLASH Au/PdNi				50	1-2331813-1
1.2±0.2	NO	0.76µm Au	20	300	YES	200	2331813-9
		0.38µm Au				100	2331813-8
		FLASH Au/PdNi				50	2331813-7
1.8 ^{+0.2} / _{-0.1}	NO	0.76µm Au	20	300	YES	200	2331813-6
		0.38µm Au				100	2331813-5
		FLASH Au/PdNi				50	2331813-4
1.8 ^{+0.2} / _{-0.1}	YES	0.76µm Au	20	300	YES	200	2331813-3
		0.38µm Au				100	2331813-2
		FLASH Au/PdNi				50	2331813-1
A	CENTER HOLD DOWN	PLATING	POCKET TAPE PITCH	REEL QUANTITY	PICK AND PLACE TAPE	MATING CYCLES	PART NUMBER

THIS DRAWING IS A CONTROLLED DOCUMENT.

OWN: B. MATTHEWS 12MAR2018
 CHK: D. HARMON 12MAR2018
 APVD: D. HARMON 12MAR2018

TE Connectivity

NAME: RECEPTACLE ASSEMBLY, VERTICAL, 84 POSITION, SLIVER 2.0

PRODUCT SPEC: 108-130021
 APPLICATION SPEC: 114-130015

SIZE: A1 CAGE CODE: - DRAWING NO: C=2331813 RESTRICTED TO: -

WEIGHT: -
 CUSTOMER DRAWING SCALE: 1:1 SHEET 4 OF 4 REV: C2