

MAX3293–MAX3295

20Mbps, +3.3V, SOT23 RS-485/ RS-422 Transmitters

General Description

The MAX3293/MAX3294/MAX3295 low-power, high-speed transmitters for RS-485/RS-422 communication operate from a single +3.3V power supply. These devices contain one differential transmitter. The MAX3295 transmitter operates at data rates up to 20Mbps, with an output skew of less than 5ns, and a guaranteed driver propagation delay below 25ns. The MAX3293 (250kbps) and MAX3294 (2.5Mbps) are slew-rate limited to minimize EMI and reduce reflections caused by improperly terminated cables.

The MAX3293/MAX3294/MAX3295 output level is guaranteed at +1.5V with a standard 54Ω load, compliant with RS-485 specifications. The transmitter draws 5mA of supply current when unloaded, and 1μA in low-power shutdown mode (DE = GND).

Hot-swap circuitry eliminates false transitions on the data cable during circuit initialization or connection to a live backplane, and short-circuit current limiting and thermal-shutdown circuitry protect the driver against excessive power dissipation.

The MAX3293/MAX3294/MAX3295 are offered in a 6-pin SOT23 package, and are specified over the automotive temperature range.

Applications

- RS-485/RS-422 Communications
- Clock Distribution
- Telecom Equipment
- Automotive
- Security Equipment
- Point-of-Sale Equipment
- Industrial Control

Typical Operating Circuit

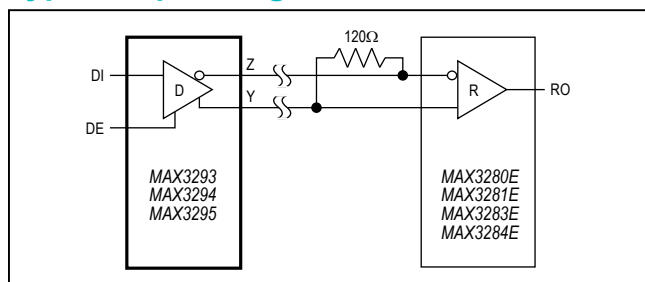

Features

- Space-Saving 6-Pin SOT23 Package
- 250kbps/2.5Mbps/20Mbps Data Rates Available
- Operate from a Single +3.3V Supply
- ESD Protection
±9kV–Human Body Model
- Slew-Rate Limited for Errorless Data Transmission (MAX3293/MAX3294)
- 1μA Low-Current Shutdown Mode
- -7V to +12V Common-Mode Input Voltage Range
- Current Limiting and Thermal Shutdown for Driver-Overload Protection
- Hot-Swap Inputs for Telecom Applications
- Automotive Temperature Range (-40°C to +125°C)

Ordering Information

PART	TEMP RANGE	PIN-PACKAGE
MAX3293AUT+T	-40°C to +125°C	6 SOT23-6
MAX3294AUT+T	-40°C to +125°C	6 SOT23-6
MAX3295AUT+T	-40°C to +125°C	6 SOT23-6
MAX3295AUT/V+T	-40°C to +125°C	6 SOT23-6

+Denotes a lead(Pb)-free/RoHS-compliant package.

T = Tape and reel.

V denotes automotive-qualified package.

Selector Guide

PART	MAXIMUM DATA RATE (Mbps)	SLEW-RATE LIMITED	TOP MARK
MAX3293AUT+T	0.25	Yes	ABNI or ABVH
MAX3294AUT+T	2.5	Yes	ABNJ or ABVI
MAX3295AUT+T	20	No	ABNK or ABVJ
MAX3295AUT/V+T	20	No	+ACSB

Pin Configuration appears at end of data sheet.



Absolute Maximum Ratings

(All voltages referenced to GND, unless otherwise noted.)

Supply Voltage (V_{CC}).....	+6V
DE, DI.....	-0.3V to +6V
Y, Z.....	-7V to +12.5V
Maximum Continuous Power Dissipation ($T_A = +70^\circ\text{C}$)	
SOT23 (derate 8.2mW/ $^\circ\text{C}$ above $+70^\circ\text{C}$).....	654.1mW

Operating Temperature Ranges

MAX32_ _AUT.....	-40°C to +125°C
Storage Temperature Range.....	-65°C to +160°C
Junction Temperature.....	+160°C
Lead Temperature (soldering, 10s).....	+300°C
Soldering Temperature (reflow).....	+260°C

Stresses beyond those listed under "Absolute Maximum Ratings" may cause permanent damage to the device. These are stress ratings only, and functional operation of the device at these or any other conditions beyond those indicated in the operational sections of the specifications is not implied. Exposure to absolute maximum rating conditions for extended periods may affect device reliability.

Electrical Characteristics

($V_{CC} = +3.3\text{V} \pm 5\%$, $T_A = T_{MIN}$ to T_{MAX} , unless otherwise noted. Typical values are at $V_{CC} = +3.3\text{V}$ and $T_A = +25^\circ\text{C}$.) (Notes 1, 2)

PARAMETER	SYMBOL	CONDITIONS	MIN	TYP	MAX	UNITS
POWER SUPPLY						
Supply Voltage	V_{CC}		3.135	3.300	3.465	V
Supply Current in Normal Operation	I_Q	No load, DI = V_{CC} or GND, DE = V_{CC}			5	mA
Supply Current in Shutdown Mode	I_{SHDN}	No load, DE = GND		1	10	μA
DRIVER						
Differential Driver Output	V_{OD}	Figure 1, DE = V_{CC} , DI = GND or V_{CC}	R = 50 Ω (RS-422), $T_A \leq +85^\circ\text{C}$	2.0	V_{CC}	V
			R = 27 Ω (RS-485), $T_A \leq +85^\circ\text{C}$	1.5	V_{CC}	
Change in Magnitude of Differential Output Voltage	ΔV_{OD}	Figure 1, R = 27 Ω or 50 Ω , DE = V_{CC} (Note 3)			0.2	V
Driver Common-Mode Output Voltage	V_{OC}	Figure 1, R = 27 Ω or 50 Ω , DE = V_{CC} , DI = V_{CC} or GND	-1		+3	V
Change in Magnitude of Common-Mode Voltage	ΔV_{OC}	Figure 1, R = 27 Ω or 50 Ω (Note 3)			0.2	V
DRIVER LOGIC						
Input High Voltage	V_{IH}	DE, DI	2.0			V
Input Low Voltage	V_{IL}	DE, DI			0.8	V
Input Current	I_{IN}	DE, DI	-2		+2	μA
Output Leakage	I_O	Y, Z DE = GND, $V_{CC} = \text{GND}$ or +3.3V	$V_{IN} = +12\text{V}$	-20	+20	μA
			$V_{IN} = -7\text{V}$	-20	+20	
Driver Short-Circuit Foldback Output Current	I_{OSFD}	$(V_{CC} - 1\text{V}) \leq V_{OUT} \leq +12\text{V}$, output high	+25			mA
		$-7\text{V} \leq V_{OUT} \leq 1\text{V}$, output high			-25	
Driver Short-Circuit Output Current	I_{OSD}	$0 \leq V_{OUT} \leq +12\text{V}$, output low	-250			mA
		$-7\text{V} \leq V_{OUT} \leq V_{CC}$, output high			+250	
Thermal-Shutdown Threshold	T_{TS}			160		$^\circ\text{C}$
Thermal-Shutdown Hysteresis	T_{TSH}			40		$^\circ\text{C}$
ESD Protection		Y, Z	Human Body Model		± 9	kV

Switching Characteristics (MAX3293)(V_{CC} = +3.3V ±5%, T_A = +25°C, unless otherwise noted. Typical values are at V_{CC} = +3.3V.)

PARAMETER	SYMBOL	CONDITIONS	MIN	TYP	MAX	UNITS
Driver Propagation Delay	t _{PLH}	Figures 2, 3; R _{DIFF} = 54Ω, C _L = 50pF	400		1300	ns
	t _{PHL}		400		1300	
Driver Differential Output Rise or Fall Time	t _R	Figures 2, 3; R _{DIFF} = 54Ω, C _L = 50pF	400		1200	ns
	t _F		400		1200	
Driver-Output Skew	t _{SKEW}	Figures 2, 3; R _{DIFF} = 54Ω, C _L = 50pF, t _{SKEW} = t _{PLH} - t _{PHL} (Note 5)	-400		+400	ns
Differential Driver-Output Skew	t _{DSKEW}	Figures 2, 3; R _{DIFF} = 54Ω, C _L = 50pF	-100		+100	ns
Maximum Data Rate		Figures 2, 3; R _{DIFF} = 54Ω, C _L = 50pF	250			kbps
Driver Enable to Output High	t _{ZH}	Figures 4, 5; S2 closed, R _L = 500Ω, C _L = 100pF			2000	ns
Driver Enable to Output Low	t _{ZL}	Figures 4, 5; S1 closed, R _L = 500Ω, C _L = 100pF			2000	ns
Driver Disable Time from Low	t _{LZ}	Figures 4, 5; S1 closed, R _L = 500Ω, C _L = 100pF			1000	ns
Driver Disable Time from High	t _{HZ}	Figures 4, 5; S2 closed, R _L = 500Ω, C _L = 100pF			1000	ns
Device-to-Device Propagation Delay Matching		Same power supply, maximum temperature difference between devices = +30°C (Note 5)			900	ns

Switching Characteristics (MAX3294)(V_{CC} = +3.3V ±5%, T_A = +25°C, unless otherwise noted. Typical values are at V_{CC} = +3.3V.)

PARAMETER	SYMBOL	CONDITIONS	MIN	TYP	MAX	UNITS
Driver Propagation Delay	t _{PLH}	Figures 2, 3; R _{DIFF} = 54Ω, C _L = 50pF	24		70	ns
	t _{PHL}		24		70	
Driver Differential Output Rise or Fall Time	t _R	Figures 2, 3; R _{DIFF} = 54Ω, C _L = 50pF	10		70	ns
	t _F		10		70	
Driver-Output Skew	t _{SKEW}	Figures 2, 3; R _{DIFF} = 54Ω, C _L = 50pF, t _{SKEW} = t _{PLH} - t _{PHL} (Note 5)	-40		+40	ns
Differential Driver-Output Skew	t _{DSKEW}	Figures 2, 3; R _{DIFF} = 54Ω, C _L = 50pF	-6		+6	ns
Maximum Data Rate		Figures 2, 3; R _{DIFF} = 54Ω, C _L = 50pF	2.5			Mbps
Driver Enable to Output High	t _{ZH}	Figures 4, 5; S2 closed, R _L = 500Ω, C _L = 100pF			400	ns
Driver Enable to Output Low	t _{ZL}	Figures 4, 5; S1 closed, R _L = 500Ω, C _L = 100pF			400	ns
Driver Disable Time from Low	t _{LZ}	Figures 4, 5; S1 closed, R _L = 500Ω, C _L = 100pF			100	ns
Driver Disable Time from High	t _{HZ}	Figures 4, 5; S2 closed, R _L = 500Ω, C _L = 100pF			100	ns
Device-to-Device Propagation Delay Matching		Same power supply, maximum temperature difference between devices = +30°C (Note 5)			46	ns

Switching Characteristics (MAX3295)(V_{CC} = +3.3V ±5%, T_A = +25°C, unless otherwise noted. Typical values are at V_{CC} = +3.3V.)

PARAMETER	SYMBOL	CONDITIONS	MIN	TYP	MAX	UNITS
Driver Propagation Delay	t _{PLH}	Figures 2, 3; R _{DIFF} = 54Ω, C _L = 50pF			25	ns
	t _{PHL}				25	
Driver Differential Output Rise or Fall Time	t _R	Figures 2, 3; R _{DIFF} = 54Ω, C _L = 50pF	T _A = -40°C to +125°C		18.5	ns
			T _A < +85°C		15	
	T _A = -40°C to +125°C			18.5		
	T _A < +85°C			15		
Driver-Output Skew	t _{SKEW}	Figures 2, 3; R _{DIFF} = 54Ω, C _L = 50pF, t _{SKEW} = t _{PLH} - t _{PHL}		5		ns
Differential Driver-Output Skew	t _{DSKEW}	Figures 2, 3; R _{DIFF} = 54Ω, C _L = 50pF		5		ns
Maximum Data Rate		Figures 2, 3; R _{DIFF} = 54Ω, C _L = 50pF, T _A ≤ +85°C		20		Mbps
				16		
Driver Enable to Output High	t _{ZH}	Figures 4, 5; S2 closed, R _L = 500Ω, C _L = 100pF			400	ns
Driver Enable to Output Low	t _{ZL}	Figures 4, 5; S1 closed, R _L = 500Ω, C _L = 100pF			400	ns
Driver Disable Time from Low	t _{LZ}	Figures 4, 5; S1 closed, R _L = 500Ω, C _L = 100pF			100	ns
Driver Disable Time from High	t _{HZ}	Figures 4, 5; S2 closed, R _L = 500Ω, C _L = 100pF			100	ns
Device-to-Device Propagation Delay Matching		Same power supply, maximum temperature difference between devices = +30°C (Note 5)			25	ns

Note 1: Devices production tested at +25°C. Limits over the operating temperature range are guaranteed by design.**Note 2:** All currents into the device are positive; all currents out of the device are negative. All voltages are referenced to device ground, unless otherwise noted.**Note 3:** ΔV_{OD} and ΔV_{OC} are the changes in V_{OD} and V_{OC}, respectively, when the DI input changes state.**Note 4:** The maximum current applies to peak current just prior to foldback current limiting.**Note 5:** Guaranteed by design; not production tested.

Test Circuits and Timing Diagrams

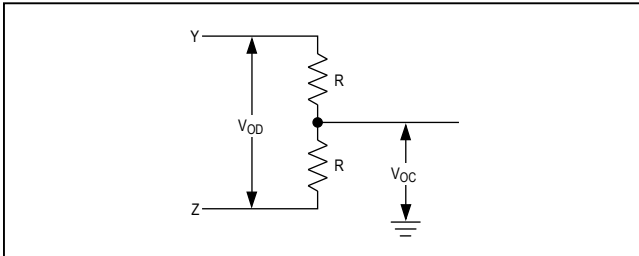

Figure 1. Driver DC Test Load

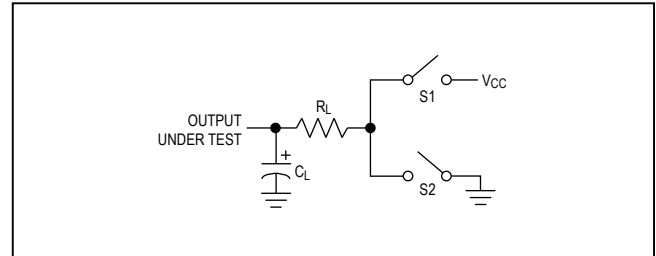

Figure 4. Enable/Disable Timing Test Load

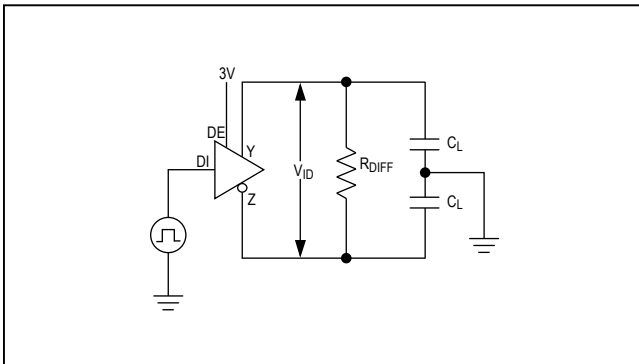

Figure 2. Driver Timing Test Circuit

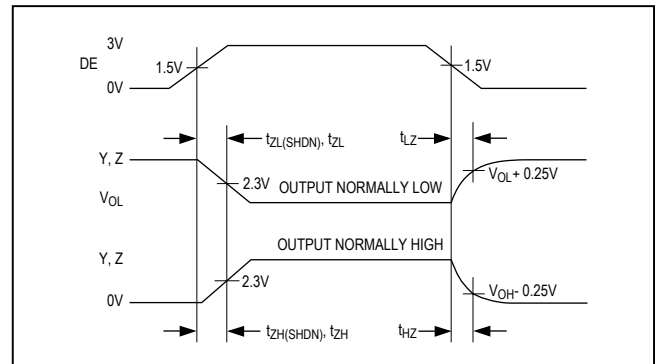

Figure 5. Driver Enable and Disable Times

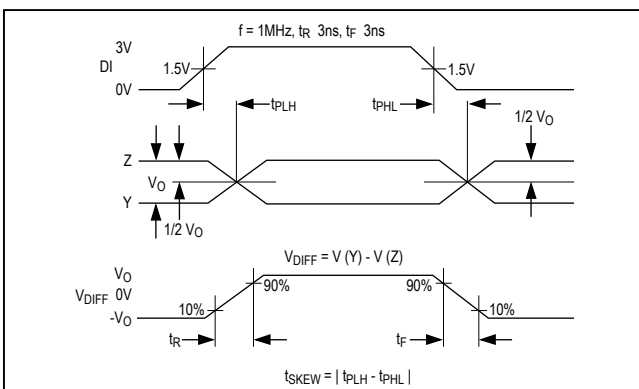
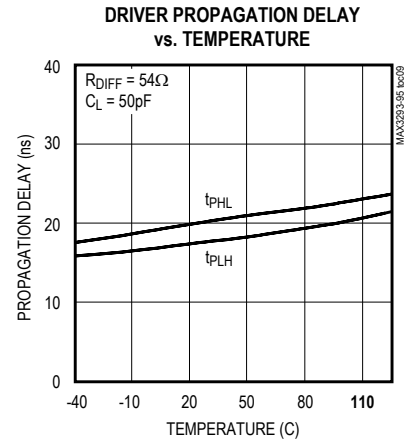
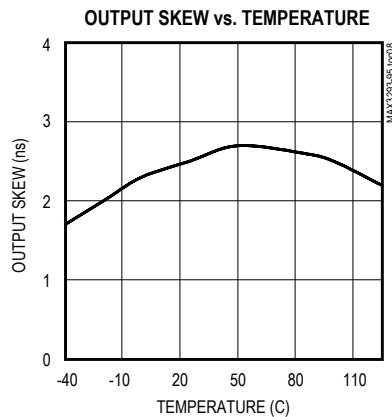
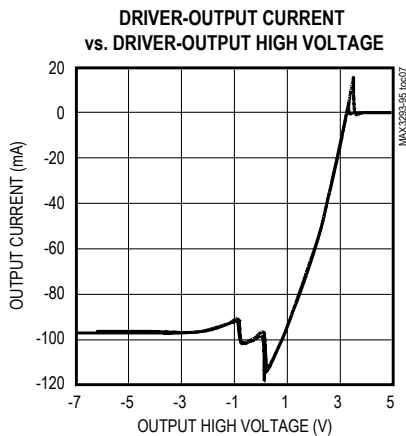
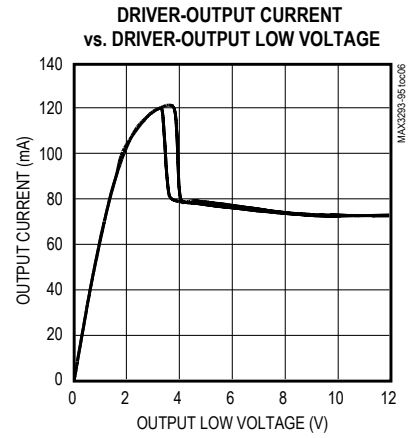
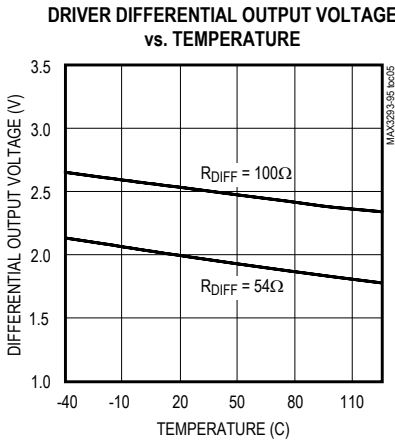
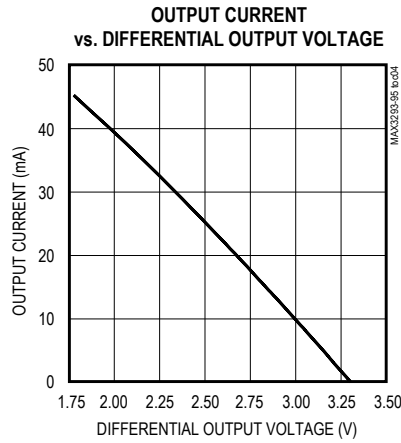
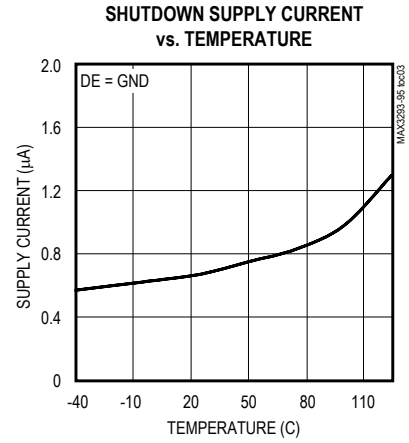
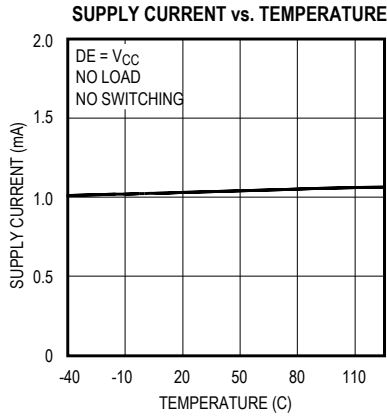
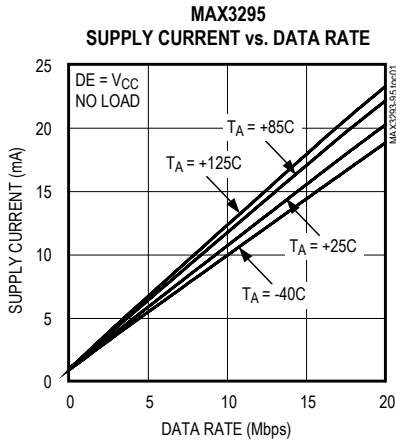

Figure 3. Driver Propagation Delays

Typical Operating Characteristics

($V_{CC} = +3.3V$, $T_A = +25^\circ C$, unless otherwise noted.)



Typical Operating Characteristics (continued)

($V_{CC} = +3.3V$, $T_A = +25^{\circ}C$, unless otherwise noted.)

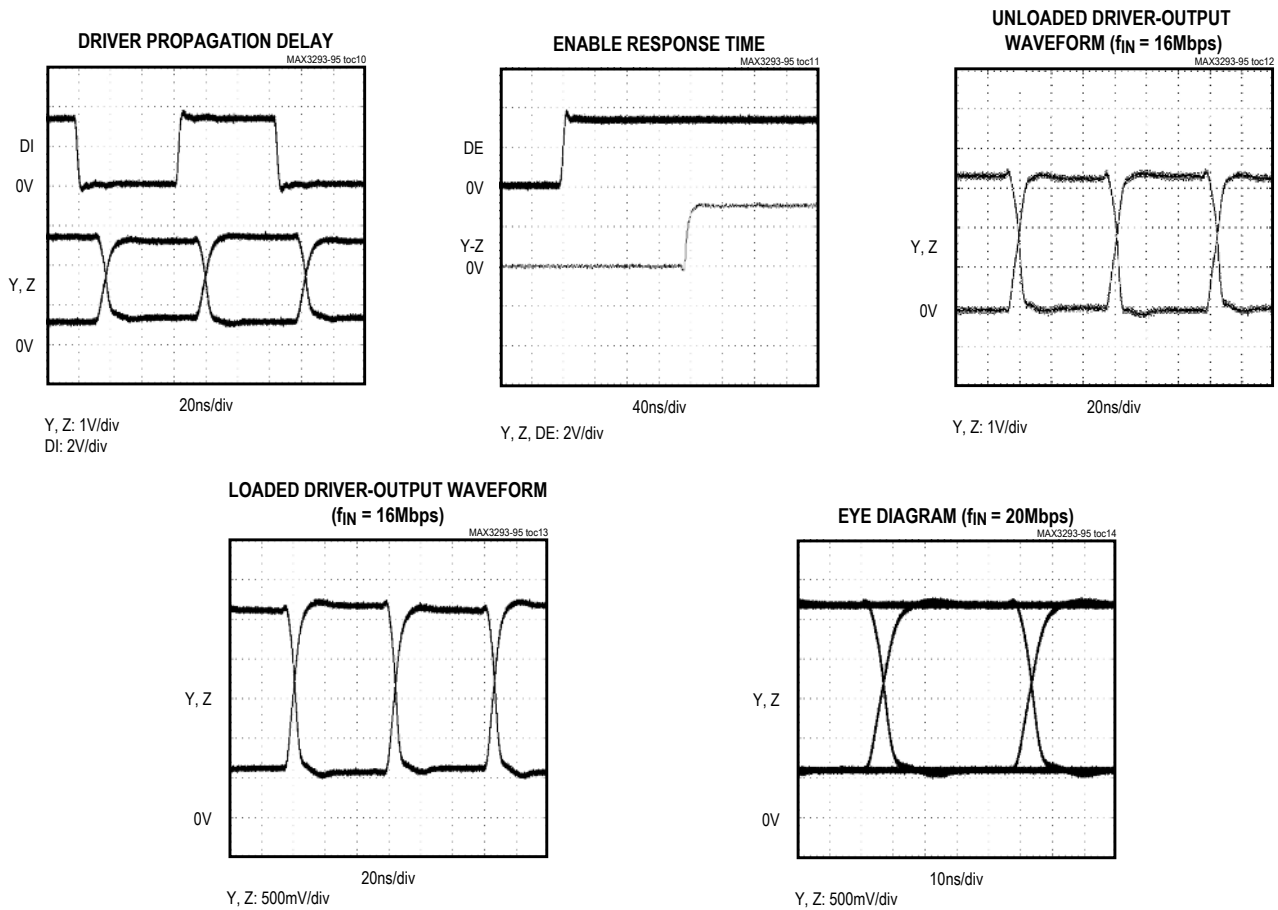

Pin Description

PIN	NAME	FUNCTION
1	DI	Driver Input. A logic low on DI forces the noninverting output (Y) low and the inverting output (Z) high. A logic high on DI forces the noninverting output (Y) high and the inverting output (Z) low.
2	V _{CC}	Positive Supply. $V_{CC} = +3.3V \pm 5\%$. Bypass V_{CC} to GND with a 0.1 μ F capacitor.
3	DE	Driver Output Enable. Force DE high to enable driver. Pull DE low to disable the driver. Hot-swap input, see the <i>Hot-Swap Capability</i> section.
4	Z	Inverting RS-485/RS-422 Output
5	GND	Ground
6	Y	Noninverting RS-485/RS-422 Output

Detailed Description

The MAX3293/MAX3294/MAX3295 are low-power transmitters for RS-485/RS-422 communication. The MAX3295 operates at data rates up to 20Mbps, the MAX3294 up to 2.5Mbps (slew-rate limited), and the MAX3293 up to 250kbps (slew-rate limited). These devices are enabled using an active-high driver enable (DE) input. When disabled, outputs enter a high-impedance state, and the supply current reduces to 1µA.

The MAX3293/MAX3294/MAX3295 have a hot-swap input structure that prevents disturbance on the differential signal lines when a circuit board is plugged into a “hot” backplane (see the *Hot-Swap Capability* section). Drivers are also short-circuit current limited and are protected against excessive power dissipation by thermal-shutdown circuitry.

Driver

The driver accepts a single-ended, logic-level input (DI) and translates it to a differential RS-485/RS-422 level output (Y and Z). Driving DE high enables the driver, while pulling DE low places the driver outputs (Y and Z) into a high-impedance state (see Table 1).

Low-Power Shutdown

Force DE low to disable the MAX3293/MAX3294/MAX3295. In shutdown mode, the device consumes a maximum of 10µA of supply current.

Hot-Swap Capability

Hot-Swap Input

When circuit boards are inserted into a “hot” or powered backplane, disturbances to the enable can lead to data errors. Upon initial circuit board insertion, the processor undergoes its power-up sequence. During this period, the output drivers are high impedance and are unable to drive the DE input of the MAX3293/MAX3294/MAX3295 to a defined logic level. Leakage currents up to 10µA from the high-impedance output could cause DE to drift to an incorrect logic state. Additionally, parasitic circuit board capacitance could

Table 1. MAX3293/MAX3294/MAX3295 (RS-485/RS-422) Transmitting Function Table

INPUTS		OUTPUTS	
DE	DI	Y	Z
0	X	Shutdown	Shutdown
1	0	0	1
1	1	1	0

X = Don't care.

cause coupling of V_{CC} or GND to DE. These factors could improperly enable the driver.

The MAX3293/MAX3294/MAX3295 eliminate all above issues with hot-swap circuitry. When V_{CC} rises, an internal pulldown circuit holds DE low for approximately 10µs. After the initial power-up sequence, the pulldown circuit becomes transparent, resetting the hot-swap tolerable input.

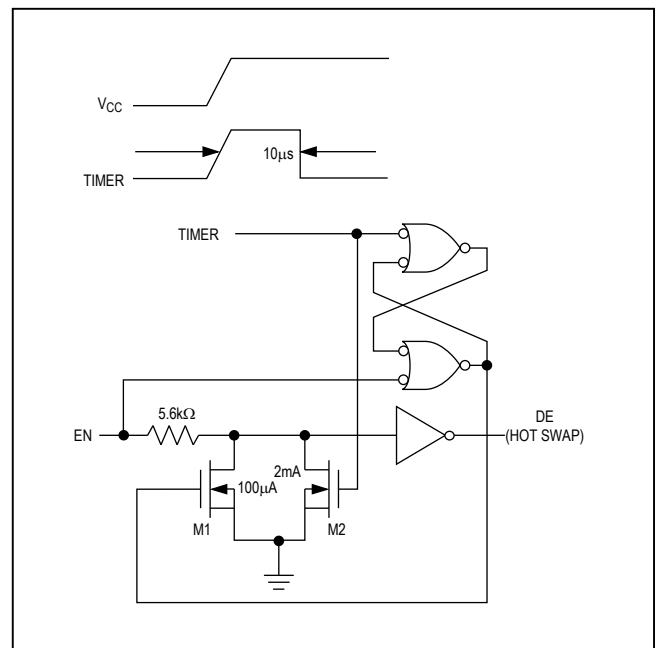

Figure 6. Simplified Structure of the Driver Enable Input (DE)

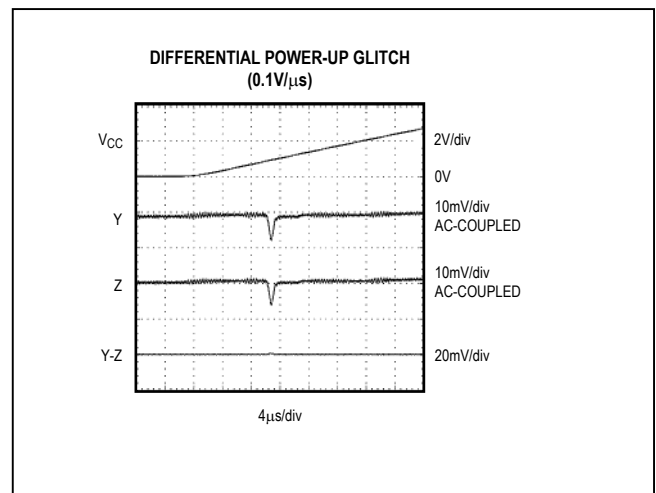

Figure 7. Differential Power-Up Glitch (0.1V/µs)

Hot-Swap Input Circuitry

The MAX3293/MAX3294/MAX3295 enable input features hot-swap capability. At the input, there are two NMOS devices, M1 and M2 (Figure 6). When V_{CC} ramps from zero, an internal $10\mu s$ timer turns on M2 and sets the SR latch, which also turns on M1. Transistors M2, a 2mA current sink, and M1, a $100\mu A$ current sink, pull DE to GND through a $5.6k\Omega$ resistor. M2 is designed to pull DE to the disabled state against an external parasitic capacitance up to $100pF$ that may drive DE high. After $10\mu s$, the timer deactivates M2 while M1 remains on, holding DE low against three-state leakages that can drive DE high. M1 remains on until an external source overcomes the required input current. At this time, the SR latch resets and M1 turns

off. When M1 turns off, DE reverts to a standard, high-impedance CMOS input. Whenever V_{CC} drops below 1V, the hot-swap input is reset.

Hot-Swap Line Transient

During a hot-swap event when the driver is connected to the line and is powered up, the driver must not cause the differential signal to drop below 200mV. Figures 7, 8, and 9 show the results of the MAX3295 during power-up for three different V_{CC} ramp rates ($0.1V/\mu s$, $1V/\mu s$, and $10V/\mu s$). The photos show the V_{CC} ramp, the single-ended signal on each side of the 100Ω termination, as well as the differential signal across the termination.

ESD Protection

Human Body Model

Figure 10 shows the Human Body Model, and Figure 11 shows the current waveform it generates when discharged into low impedance. This model consists of a $100pF$ capacitor charged to the ESD voltage of interest, which is then discharged into the device through a $1.5k\Omega$ resistor.

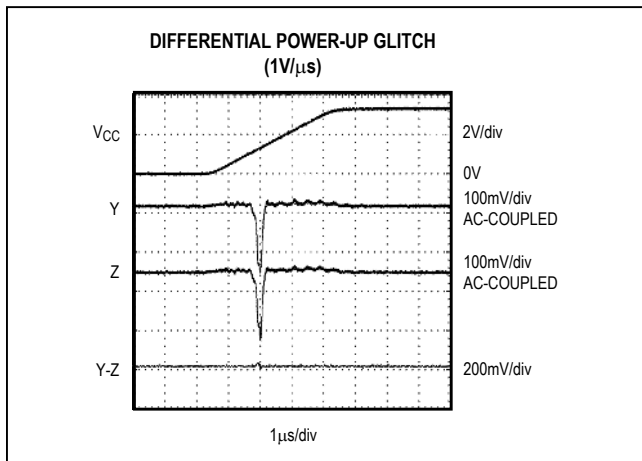

Figure 8. Differential Power-Up Glitch ($1V/\mu s$)

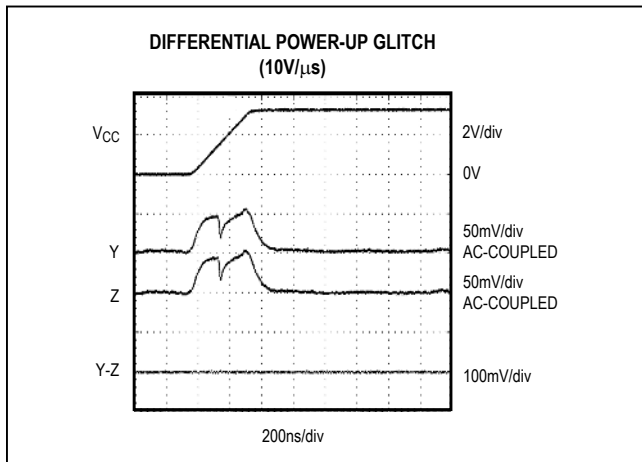

Figure 9. Differential Power-Up Glitch ($10V/\mu s$)

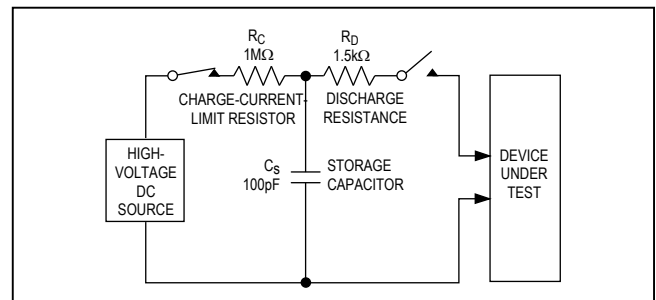

Figure 10. Human Body ESD Test

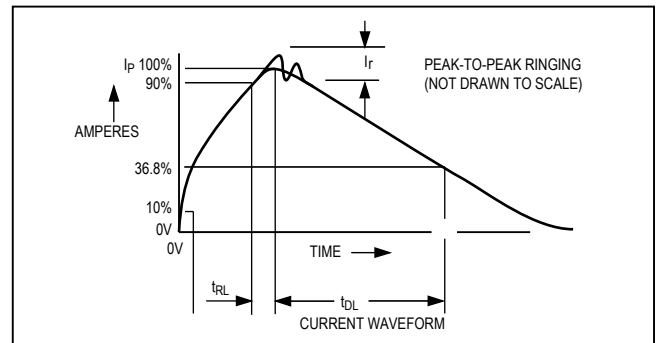

Figure 11. Current Waveform

**Reduced EMI and Reflections
(MAX3293/MAX3294)**

The MAX3293/MAX3294 are slew-rate limited, minimizing EMI and reducing reflections caused by improperly terminated cables. Figure 12 shows Fourier analysis of the MAX3295 transmitting a 125kHz signal. High-frequency harmonics with large amplitudes are evident. Figure 13 shows the same information, but for the slew-rate-limited MAX3293, transmitting the same signal. The high-frequency harmonics have much lower amplitudes, and the potential for EMI is significantly reduced.

To minimize reflections, the line should be terminated at both ends in its characteristic impedance, and stub lengths off the main line should be kept as short as possible. The slew-rate-limited MAX3293 and MAX3294 are more tolerant of imperfect termination.

Driver-Output Protection

Two mechanisms prevent excessive output current and power dissipation caused by faults or by bus contention. The first, a foldback current limit on the output stage, provides immediate protection against short circuits over the whole common-mode voltage range (see the *Typical Operating Characteristics*). The second, a thermal-shut-down circuit, forces the driver outputs into a high-impedance state if the die temperature exceeds +160°C.

Chip Information

PROCESS: BiCMOS

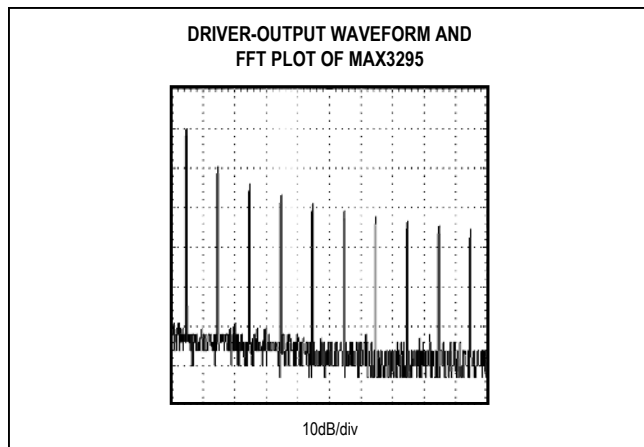

Figure 12. Driver-Output Waveform and FFT Plot of MAX3295 Transmitting a 125kHz Signal

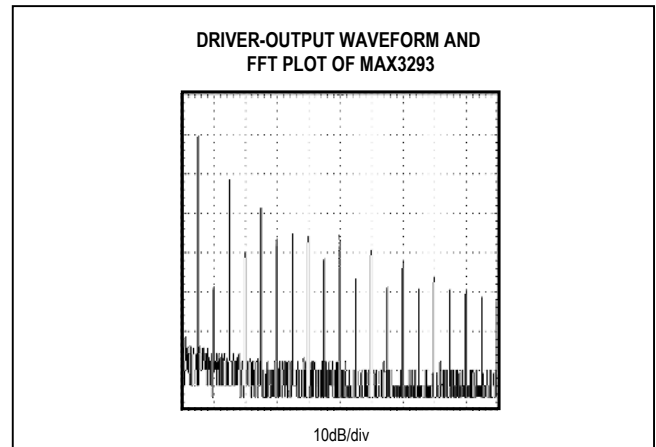
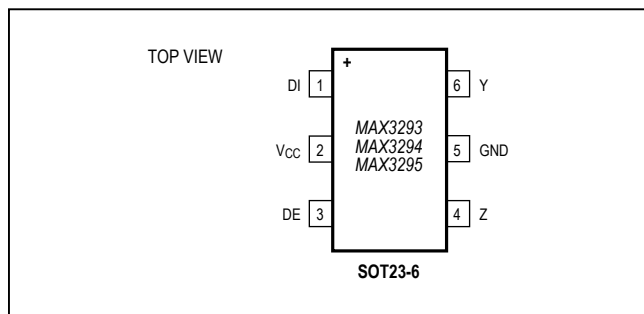

Figure 13. Driver-Output Waveform and FFT Plot of MAX3293 Transmitting a 125kHz Signal

Pin Configuration



Package Information

For the latest package outline information and land patterns (footprints), go to www.maximintegrated.com/packages. Note that a “+”, “#”, or “-” in the package code indicates RoHS status only. Package drawings may show a different suffix character, but the drawing pertains to the package regardless of RoHS status.

PACKAGE TYPE	PACKAGE CODE	OUTLINE NO.	LAND PATTERN NO.
6 SOT23	U6CN+2	21-0058	90-0175

Revision History

REVISION NUMBER	REVISION DATE	DESCRIPTION	PAGES CHANGED
3	3/11	Added lead-free parts to the <i>Ordering Information</i> and <i>Selector Guide</i> tables	1
4	12/14	Added MAX3295AUT/V+T to <i>Ordering Information</i>	1

For pricing, delivery, and ordering information, please contact Maxim Direct at 1-888-629-4642, or visit Maxim Integrated's website at www.maximintegrated.com.

Maxim Integrated cannot assume responsibility for use of any circuitry other than circuitry entirely embodied in a Maxim Integrated product. No circuit patent licenses are implied. Maxim Integrated reserves the right to change the circuitry and specifications without notice at any time. The parametric values (min and max limits) shown in the Electrical Characteristics table are guaranteed. Other parametric values quoted in this data sheet are provided for guidance.