



LED16_24 Series

Constant current power LED Driver - Wide Input - Non-Isolated & Regulated

LED Driver

- ⊕ SMD package, simple and convenient
- ⊕ High efficiency up to 96%
- ⊕ Short Circuit Protection (SCP)
- ⊕ Ultra wide range voltage input and output
- ⊕ Constant current mode, great power output
- ⊕ AC-DC, EMC recommended circuit
- ⊕ PWM dimming & analogue dimming
- ⊕ Remote ON/OFF
- ⊕ RoHS and UL Compliance

The LED16_24 is a series of step-down constant current source designed for driving high power LEDs. It features high efficiency, wide input voltage range, high operating temperature, PWM and analogue dimming, remote ON/OFF control, and SMD package which facilitates the installation.

It is widely used in LED illumination areas such as decorative light, special control light, backlight, commercial light, streetlight, in-house light and car light, etc.



Specifications					
Item	Test condition	Min	Typ	Max	Units
Utmost input voltage	≤10 seconds	5		55	VDC
Recommended input voltage		5.5	24	48	VDC
Input filter	Capacitor (1μF)				
Output voltage range	Vin=48V	3.3		36	VDC
Input-Output voltage drop	Vin=5.5~48V, 1~10LEDs	2		4	VDC
Output current range	See the product program				
Output current accuracy			±2	±5	%
Output current stability	Vin=48V, Vo=3.3V~36V			±1	%
Internal power dissipation	Vin=24V, 5LEDS				
Temperature coefficient	-40 °C to +71 °C ambient			0.015	%/°C
Efficiency at full load				96	%
Ripple & Noise (Vp-p)				120	mV
Short circuit protection	Continuous, automatic recovery				
Operating temperature range	• 300mA / 350mA • 500mA/ 600mA/ 700mA	-40		85	°C
		-40		71	°C
Storage temperature range		-55		125	°C
Maximum case temperature				100	°C
Maximum capacitive Load			1000		μF
Operating frequency range		320	370	420	kHz
MTBF	MIL-HDBK-217F(+25°C)		2,000,000		Hours
Case Material	Epoxy Resin (UL94-V0)				
Dimensions			23.86*18.10*8.00		mm
Weight			6		g

PWM dimming and ON/OFF control (leave open if not used)					
Item	Test condition	Min	Typ	Max	Units
Remote ON/OFF	ON OFF (shutdown)			Open or 2.8V<Vc<6V Vc<0.6V	
Remote pin current	Vc=5V			1	mA
Quiescent input current	Vin=24V, Vc <0.6V		400		μA
PWM frequency				200	Hz

Analogue dimming (leave open if not used)					
Item	Test condition	Min	Typ	Max	Units
Input voltage range	Vin=5.5-48V			0-15V	
Output current range	Vin=5.5-48V			0%-100%	
Control voltage range	Full on Full off			0.2V±50mV 4.5V±200mV	
Driving current	Vc=5V			0.6mA(max)	

EMC specifications					
EMI conducted	EN55015 power port*				
RFI conducted	EN55015	CISPR22	class B*		
ESD	IEC/EN 61000-4-2	level 2	contact ±4KV	perf. Criteria B*	
R/S	IEC/EN 61000-4-3	level 3	(10V/m)	perf. Criteria A	
EFT	IEC/EN 61000-4-4	level 2	(±1KV)	perf. Criteria B*	
Surge	IEC/EN 61000-4-5	level 2	(±1KV)	perf. Criteria B*	
C/S	IEC/EN 61000-4-6	level 3	(10Vr.ms)	perf. Criteria A	

* Refer to EMI/EMC recommended circuit

Model selection:

LEDC_xx-###
LED=Type; C=Case; yy=Vin; ###= Output Current

Example:

LED16_24-300
LED= Series T16= SMT16; yy= 24VDC nominal; 300= 0,3A

LEDT16_24 Series

Constant current power LED Driver - Wide Input - Non-Isolated & Regulated

Part Number	Input Voltage [VDC] Nominal (Range)	Output Voltage [VDC]	Output Current [mA]	Dimming control	Efficiency [% , typ]
LEDT16_24-300	24 (5.5-48)	3.3-36	0-300	PWM+Analogue	96
LEDT16_24-350	24 (5.5-48)	3.3-36	0-350	PWM+Analogue	96
LEDT16_24-500	24 (5.5-48)	3.3-36	0-500	PWM+Analogue	96
LEDT16_24-600	24 (5.5-48)	3.3-36	0-600	PWM+Analogue	96
LEDT16_24-700	24 (5.5-48)	3.3-36	0-700	PWM+Analogue	96

Input vs. Output

Input voltage	Output voltage range [VDC]	Output constant current [mA]	Output power [W, max]
48	3.3-36.0	300	10.80
36	3.3-32.0	300	9.60
24	3.3-21.0	300	6.30
20	3.3-17.0	300	5.10
15	3.3-13.2	300	3.96
12	3.3-10.0	300	3.00
5.5	3.3-4.0	300	1.20

Input voltage	Output voltage range [VDC]	Output constant current [mA]	Output power [W, max]
48	3.3-36.0	600	21.60
36	3.3-32.0	600	19.20
24	3.3-21.0	600	12.60
20	3.3-17.0	600	10.20
15	3.3-13.2	600	7.92
12	3.3-10.0	600	6.00
5.5	3.3-4.0	600	2.40

Input voltage	Output voltage range [VDC]	Output constant current [mA]	Output power [W, max]
48	3.3-36.0	350	12.60
36	3.3-32.0	350	11.20
24	3.3-21.0	350	7.35
20	3.3-17.0	350	5.95
15	3.3-13.2	350	4.62
12	3.3-10.0	350	3.50
5.5	3.3-4.0	350	1.40

Input voltage	Output voltage range [VDC]	Output constant current [mA]	Output power [W, max]
48	3.3-36.0	700	25.20
36	3.3-32.0	700	22.40
24	3.3-21.0	700	14.70
20	3.3-17.0	700	11.90
15	3.3-13.2	700	9.24
12	3.3-10.0	700	7.00
5.5	3.3-4.0	700	2.80

Input voltage	Output voltage range [VDC]	Output constant current [mA]	Output power [W, max]
48	3.3-36.0	500	18.00
36	3.3-32.0	500	16.00
24	3.3-21.0	500	10.50
20	3.3-17.0	500	8.50
15	3.3-13.2	500	6.60
12	3.3-10.0	500	5.00
5.5	3.3-4.0	500	2.00

Typical application circuits

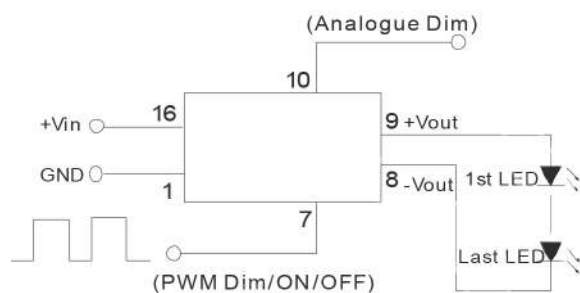

(Figure 1) Series Application

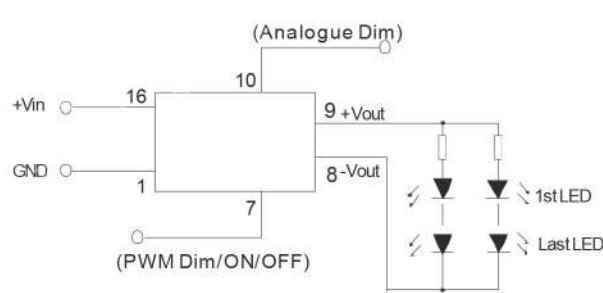

(Figure 2) Parallel-series Application

If it is necessary to protect LED in actual application, you could connect a PTC to the input of every channel or all channels, as shown in Figure 2.

Note: The negative output terminal can't connect GND, or the module may be damaged.

LEDT16_24 Series

Constant current power LED Driver - Wide Input - Non-Isolated & Regulated

Digital dimming control

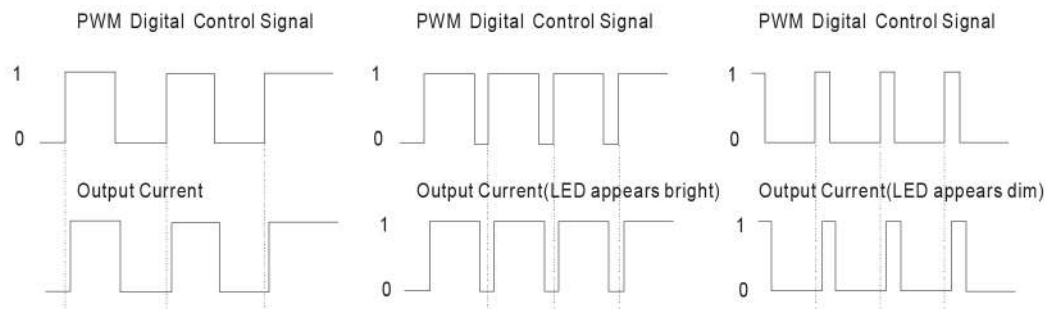

For the rated frequency PWM dimming, the output current of driver matters to the pulse width of the PWM signal, and the numerate please refer to the following formula:

$$I_{o_set} = \frac{(DT-0.6)}{T} I_{o_norm}$$

I_{o_set} refers to the expected output current value.

I_{o_norm} refers to the rated output current

D refers to the pulse width of the PWM signal

T refers to the cycle of the PWM signal

Note: The formula only supplies as a reference, and the output current may be a little deviation with different load. The $T_{on}(min)$ of PWM signal must be greater than 0.7ms, or the driver can't be operated normally.

It is natural for the driver to generate an audibly noise in dimming process, because the frequency of the control circuit is within human audibly range (20Hz~20KHz). In order to avoid the human eye can observe the LED flashes, the PWM dimming frequency is recommended to set above 100Hz.

Analogue dimming control and application sample

Analogue dimming circuit

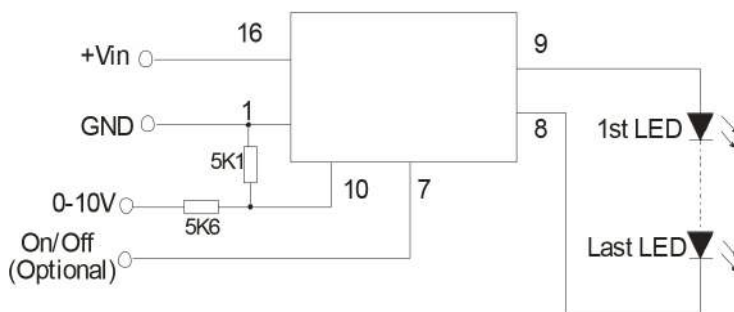

Analogue input voltage vs. output

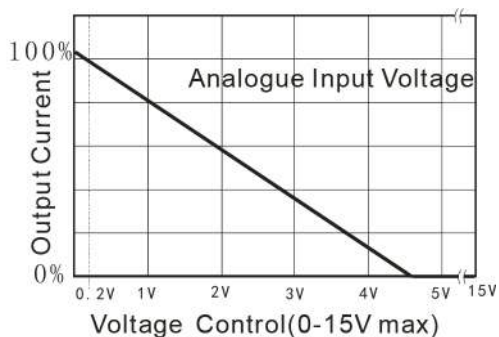

LEDT16_24 Series

Constant current power LED Driver - Wide Input - Non-Isolated & Regulated

EMC recommended circuit

EMI/RFI conducted EN55022 recommended circuit

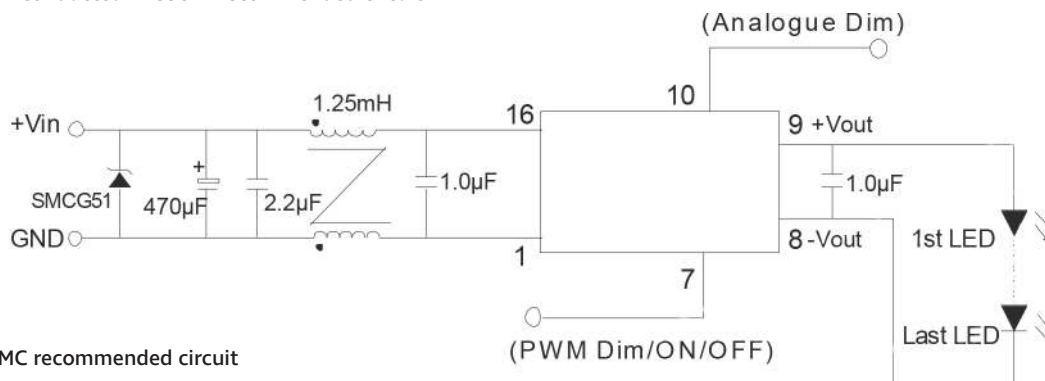

EMI/EMC recommended circuit

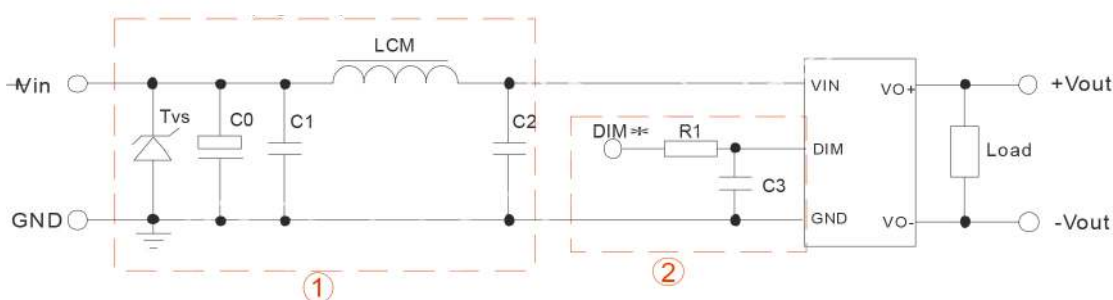

Note:

1. DIM pin is the module's PWM dimming pin as shown in EMI/EMC recommended circuit.
2. While adding circuit (2) it may extend the PWM dimming output reaction time.

EMI/EMC standard:

Item	Standard	Level	Predicate	Remark
EMI conducted	EN 55015	Power port	Qualification	Add external circuit (1)
ESD	IEC 61000-4-2:2001	Level 2	B	±4KV Add external circuit (2)
Surge	IEC 61000-4-5:2004	Level 2	B	±1KV Add external circuit (1)
EFT	IEC 61000-4-4:2004	Level 2	B	±1KV Add external circuit (1)

1. 24V input series, 24V output series is subject to CY (CY : 1nF/2KV).
2. It is not needed to add the component in the peripheral circuit when parameter with the symbol of „-“.

Recommended parameter:

Components	Specifications
Tvs	SMCJ48A,1500W ⓧ Bringtking ⓧ
LCM	6.8µH CD43 ⓧ CEAIYA ⓧ
C0	470µF/50V ⓧ CapXon ⓧ
C1	4.7µF/50V 1210 (TORCH)
C2	2.2µF/50V 1210 (TORCH)
C3	470pF/100V 0805 (TORCH)
R1	680Ω 0805 (can replaced by inductance or magnetic bead)

LEDT16_24 Series

Constant current power LED Driver - Wide Input - Non-Isolated & Regulated

AC input recommended circuit

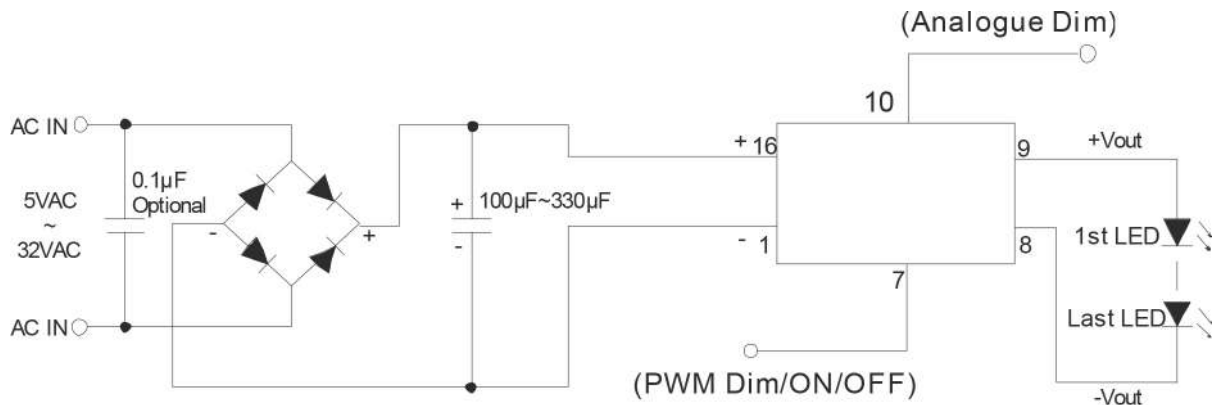

Typical characteristics

Temperature Derating Graph

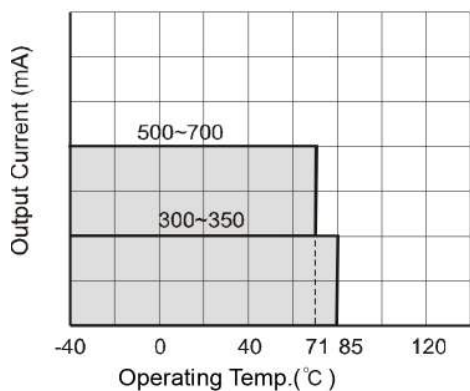

Reflow soldering profile

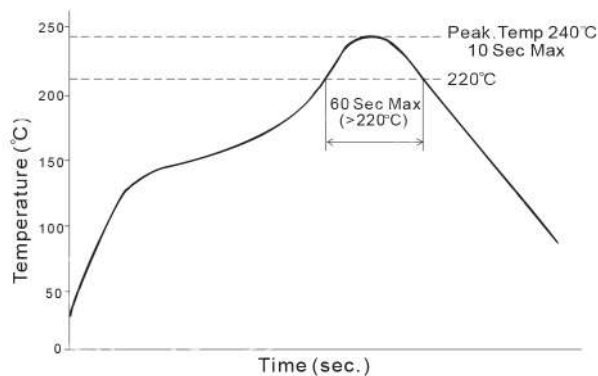

Remark: The curve applies only to the hot air reflow soldering.

Efficiency

Vin=12V

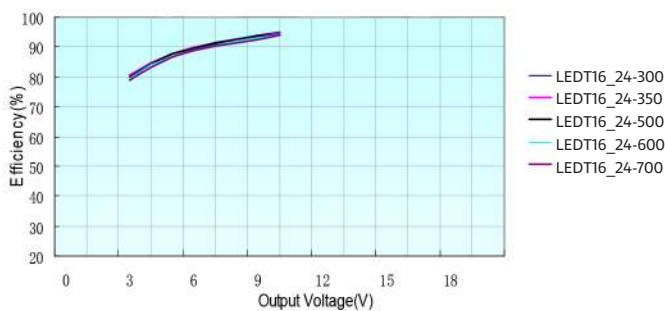

Vin=24V

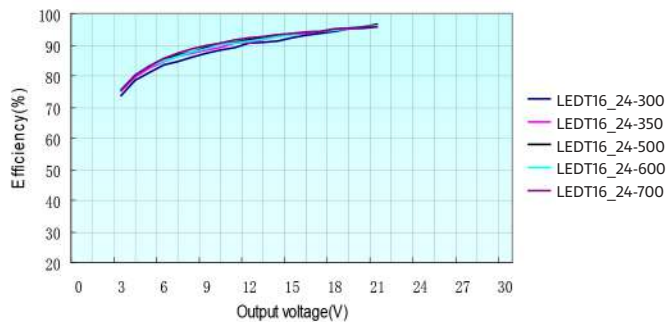

Vin=36V

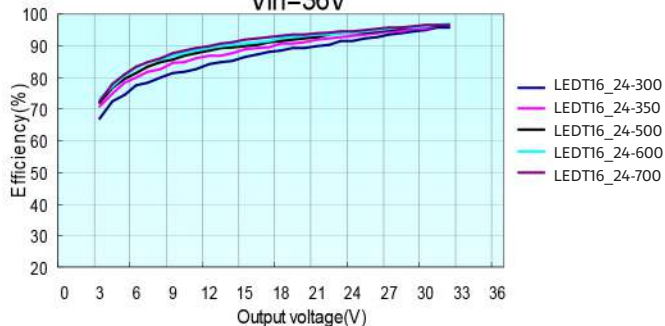

Vin=48V

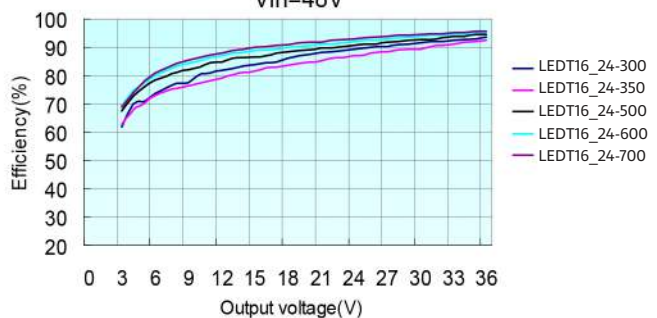

LEDT16_24 Series

Constant current power LED Driver - Wide Input - Non-Isolated & Regulated

Mechanical dimensions

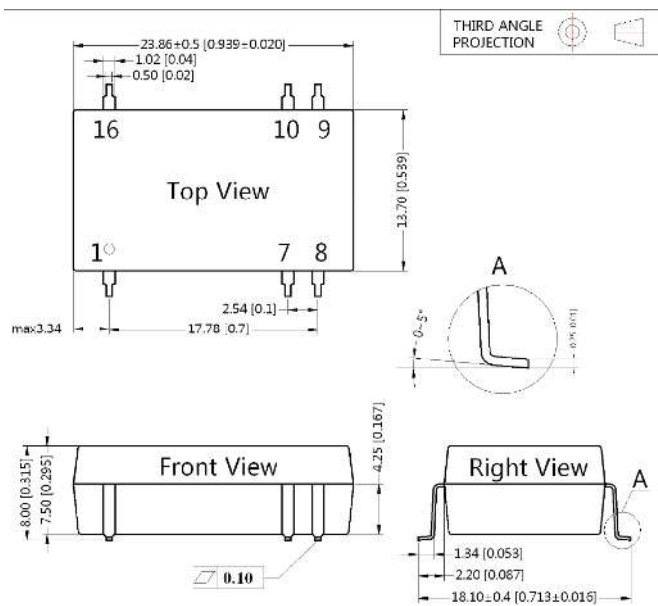

Note:
 Unit: mm[inch]
 Pin section tolerances: ± 0.10mm[± 0.004inch]
 General tolerances: ± 0.25mm[± 0.010inch]

Recommended footprint

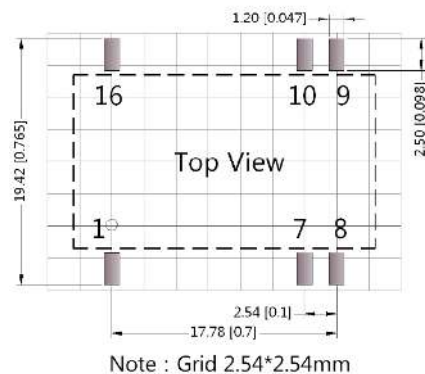

PIN CONNECTION	
Pin	Function
1	GND
7	ON/OFF/PWM
8	-Vout
9	+Vout
10	ANALOGUE DIMMING
16	Vin

NC:No Connection

Tube packing dimensions

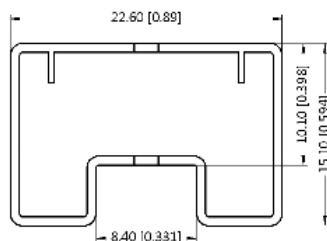

- Note:
1. If the product is not operated within the required load range, the product performance cannot be guaranteed to comply with all parameters in the datasheet;
 2. The maximum capacitive load offered were tested at nominal input voltage and full load;
 3. Unless otherwise specified, parameters in this datasheet were measured under the conditions of $T_a=25^\circ\text{C}$, humidity<75% with nominal input voltage and rated output load;
 4. All index testing methods are based on our Company's corporate standards;
 5. We can provide product customization service;
 6. Specifications are subject to change without prior notice.