

P	LTR	DESCRIPTION	DATE	DWN	APVD
	A	INITIAL RELEASE	05APR2021	BS	CB

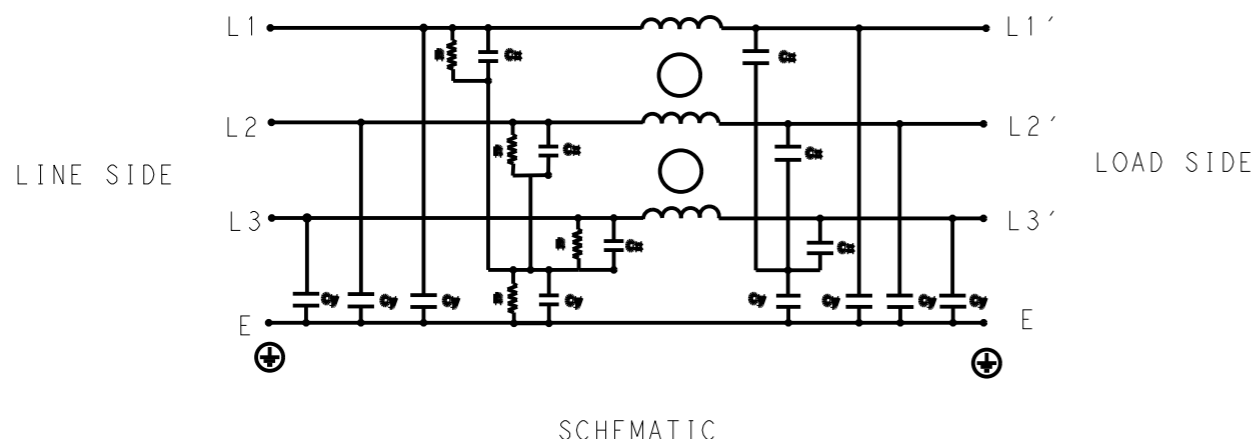

SAFETY ORGANIZATIONS  
 THIS FILTER WILL BE FORMALLY RECOGNIZED, CERTIFIED OR APPROVED BY THE LISTED AGENCY. THEREFORE, ALL TEST/REQUIREMENTS SPECIFIED IN THE LATEST REVISION OF THE FOLLOWING AGENCY STANDARDS WILL BE MET:

UL APPROVED 50A 520V 50Hz/60Hz 40°C  
 CSA PENDING 50A 520V 50Hz/60Hz 40°C

OPERATING SPECIFICATION  
 LINE CURRENT/VOLTAGE: 50A, 520VAC  
 LINE FREQUENCY: 50/60Hz

MAXIMUM LEAKAGE CURRENT: 18mA @ 230VAC, 50Hz  
 OPERATING AMBIENT TEMPERATURE RANGE @ RATED CURRENT: -25°C TO +40°C  
 IN AN AMBIENT, T<sub>a</sub>, HIGHER THAN 40°C, THE MAXIMUM OPERATING CURRENT, I<sub>o</sub>, IS AS FOLLOWS:

$$I_o = I_r \sqrt{\frac{85 - T_a}{45}}$$

RELIABILITY SPECIFICATIONS  
 STORAGE TEMPERATURE: -40°C TO +85°C  
 HUMIDITY: 21 DAYS @ 40°C AND 95% RH

TEST SPECIFICATIONS  
 INDUCTANCE, NOMINAL: 1.4mH

CAPACITANCE @ 1kHz  
 LINE TO GROUND, NOMINAL: 1.86µF  
 LINE TO LINE, NOMINAL: 5µF

DISCHARGE RESISTOR  
 L/G I.R. 1MΩ 1W  
 L/L I.R. 2MΩ 1W  
 L/N I.R. XXX  
 N/G I.R. XXX  
 IR (NO DISCHARGE RESISTOR) 20°C, 50% RH AND 100VDC, MIN: 6MΩ

RECOMMENDED RECEIVING INSPECITON HIPOT  
 LINE TO GROUND FOR 1 MINUTE: 2856VDC  
 LINE TO LINE FOR 1 MINUTE: 2236VDC

FILTER APPROVAL  
 THE BEST WAY TO SELECT AND QUALIFY A FILTER IS FOR YOUR ENGINEERING TO TEST THE UNIT IN YOUR EQUIPMENT.

TYPICAL INSERTION LOSS  
 COMMON MODE 50/50Ω; DIFFERENTIAL MODE 50/50Ω

MHz	0.01	0.05	0.15	0.5	1	3	5	10	30
CM	58	54	45	34	31	32	29	42	36
DM	56	51	48	42	40	48	46	52	54

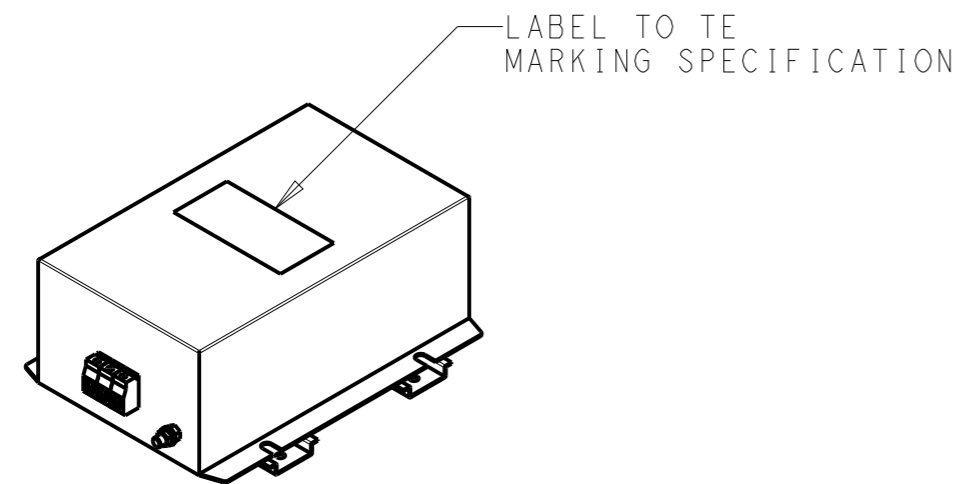

THIS DRAWING IS A CONTROLLED DOCUMENT.		DWN 05APR2021 BAPAT SAHAS	<b>TE</b> TE Connectivity	
DIMENSIONS: mm		CHK 05APR2021 CHRIS BOLLE	NAME POWER LINE FILTER FOR DIN 35 RAIL INSTALLATION 50KEMS10BFPDHM	
		APVD 05APR2021 CHRIS BOLLE		
TOLERANCES UNLESS OTHERWISE SPECIFIED: 0 PLC ±- 1 PLC ±0.5 2 PLC ±0.40 3 PLC ±0.130 4 PLC ±0.0500 ANGLES ±-		PRODUCT SPEC	SIZE CAGE CODE DRAWING NO RESTRICTED TO A300779 C-7-1609968-1 -	
		APPLICATION SPEC		
MATERIAL FINISH		WEIGHT	SCALE SHEET OF REV 1:4 1 OF 2 A	
		CUSTOMER DRAWING		

REVISIONS

P	LTR	DESCRIPTION	DATE	DWN	APVD
		SEE SHEET 1			

NOTE 1 GROUND CONNECTION:  
 FOR ELECTRICAL SAFETY AND FILTER PERFORMANCE  
 UNIT MUST HAVE A GOOD GROUND CONNECTION.  
 TORQUE OUTER TERMINAL SCREWS: 1.2Nm / 10.8 in.lbs  
 TORQUE GROUND NUTS: 2.5-3Nm

NOTE 2 INPUT OUTPUT CONNECTION TERMINAL  
 AWG SIZE: 26-8 AWG  
 WIRE SECTION: 10 mm<sup>2</sup>  
 THREADED BOLT SIZE FOR GROUND: M6

NOTE 3 SUPPLIED WITH DIN RAIL BRACKET

NOTE 4 DRAWINGS SHOWS DIN RAIL FOR  
 REFERENCE ONLY

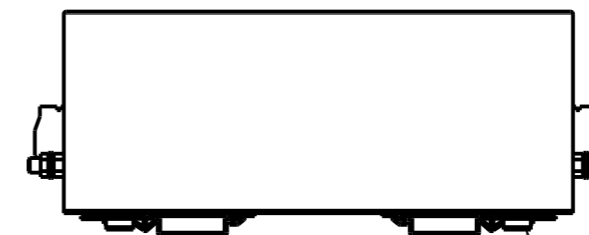
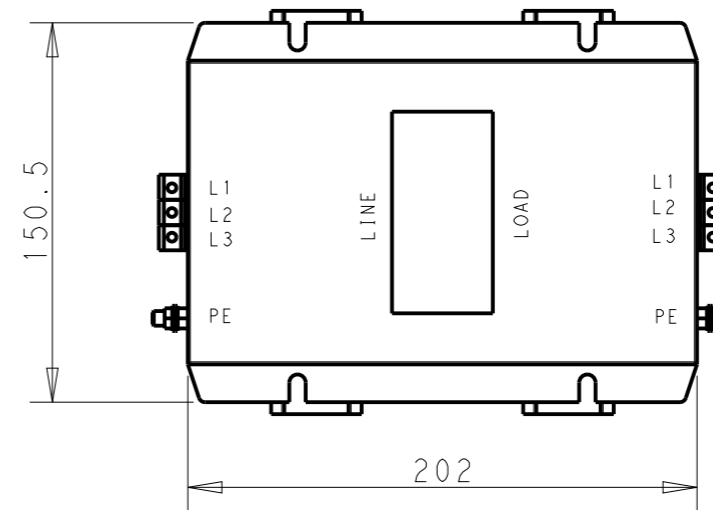
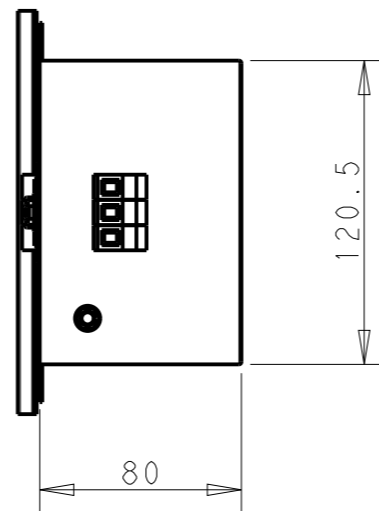
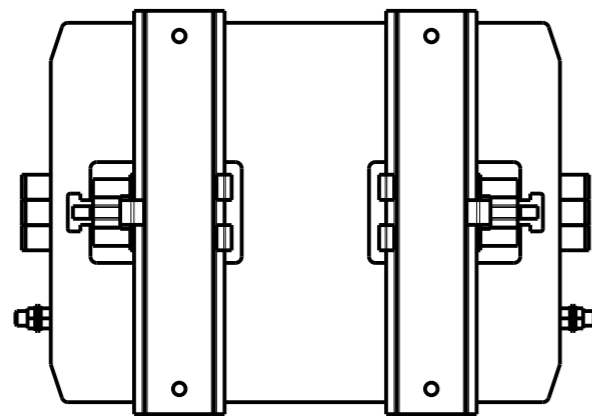

DIN RAIL CHANNEL      DIN 35 BRACKET

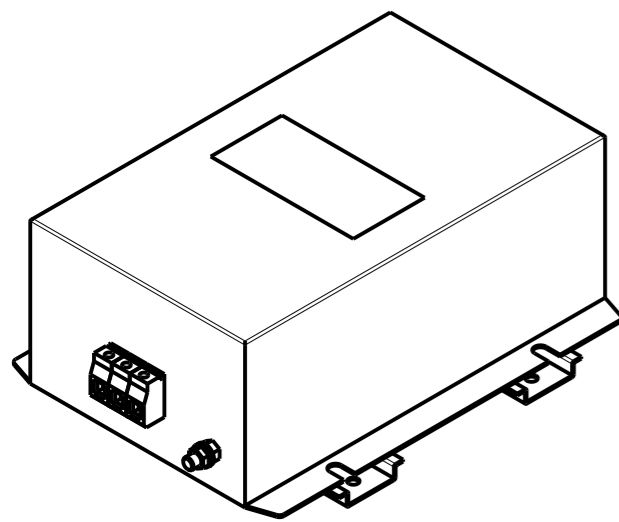

FRONT SIDE

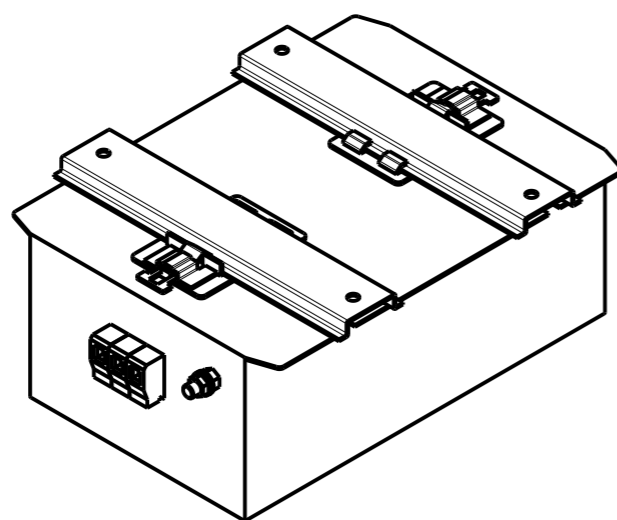

REAR SIDE

THIS DRAWING IS A CONTROLLED DOCUMENT.

DIMENSIONS: mm	TOLERANCES UNLESS OTHERWISE SPECIFIED:
	0 PLC ±-
	1 PLC ±0.5
	2 PLC ±0.40
	3 PLC ±0.130
	4 PLC ±0.0500
	ANGLES ±-
MATERIAL	FINISH
-	-
-	-

DWN	05APR2021
BAPAT SAHAS	
CHK	05APR2021
CHRIS BOLLE	
APVD	05APR2021
CHRIS BOLLE	
PRODUCT SPEC	-
APPLICATION SPEC	-
WEIGHT	-
CUSTOMER DRAWING	

		TE Connectivity	
NAME POWER LINE FILTER FOR DIN 35 RAIL INSTALLATION 50KEMS10BFPDHM			
SIZE	CAGE CODE	DRAWING NO	RESTRICTED TO
A3	00779	C-7-1609968-1	-
SCALE		SHEET	REV
1:3		2 OF 2	A