

FEATURES

Extremely low harmonic distortion

- 102 dBc HD2 at 10 MHz
- 83 dBc HD2 at 70 MHz
- 77 dBc HD2 at 100 MHz
- 101 dBc HD3 at 10 MHz
- 97 dBc HD3 at 70 MHz
- 91 dBc HD3 at 100 MHz

Low input voltage noise: 2.3 nV/√Hz

High speed

- 3 dB bandwidth of 1.4 GHz, G = 2
- Slew rate: 6800 V/μs, 25% to 75%
- Fast overdrive recovery of <1 ns

±0.5 mV typical offset voltage

Externally adjustable gain

Stable for differential gains ≥2

Differential-to-differential or single-ended-to-differential operation

Adjustable output common-mode voltage

Single-supply operation: 3.3 V to 5 V

APPLICATIONS

ADC drivers

Single-ended-to-differential converters

IF and baseband gain blocks

Differential buffers

Line drivers

GENERAL DESCRIPTION

The ADA4939-1/ADA4939-2 are low noise, ultralow distortion, high speed differential amplifiers. They are an ideal choice for driving high performance ADCs with resolutions up to 16 bits from dc to 100 MHz. The output common-mode voltage is user adjustable by means of an internal common-mode feedback loop, allowing the ADA4939-1/ADA4939-2 output to match the input of the ADC. The internal feedback loop also provides exceptional output balance as well as suppression of even-order harmonic distortion products.

With the ADA4939-1/ADA4939-2, differential gain configurations are easily realized with a simple external feedback network of four resistors that determine the closed-loop gain of the amplifier.

The ADA4939-1/ADA4939-2 are fabricated using Analog Devices, Inc., proprietary silicon-germanium (SiGe), complementary bipolar process, enabling them to achieve very low levels of distortion with an input voltage noise of only 2.3 nV/√Hz. The low dc offset and excellent dynamic performance of the ADA4939-1/ADA4939-2 make them well suited for a wide variety of data acquisition and signal processing applications.

Rev. A

Document Feedback

Information furnished by Analog Devices is believed to be accurate and reliable. However, no responsibility is assumed by Analog Devices for its use, nor for any infringements of patents or other rights of third parties that may result from its use. Specifications subject to change without notice. No license is granted by implication or otherwise under any patent or patent rights of Analog Devices. Trademarks and registered trademarks are the property of their respective owners.

FUNCTIONAL BLOCK DIAGRAMS

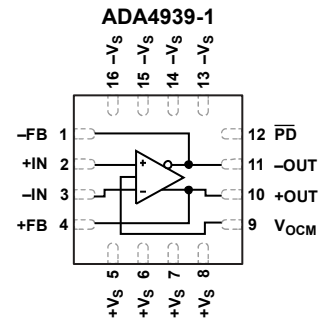

Figure 1. ADA4939-1

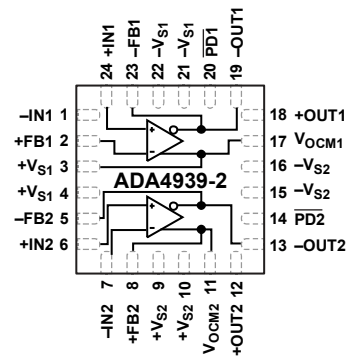

Figure 2. ADA4939-2

The ADA4939-1 (single) is available in a 3 mm × 3 mm, 16-lead LFCSP, and the ADA4939-2 (dual) is available in a 4 mm × 4 mm, 24-lead LFCSP. The pinouts are optimized to facilitate printed circuit board (PCB) layout and minimize distortion. The ADA4939-1/ADA4939-2 are specified to operate over the -40°C to +105°C temperature range; both operate on supplies between 3.3 V and 5 V.

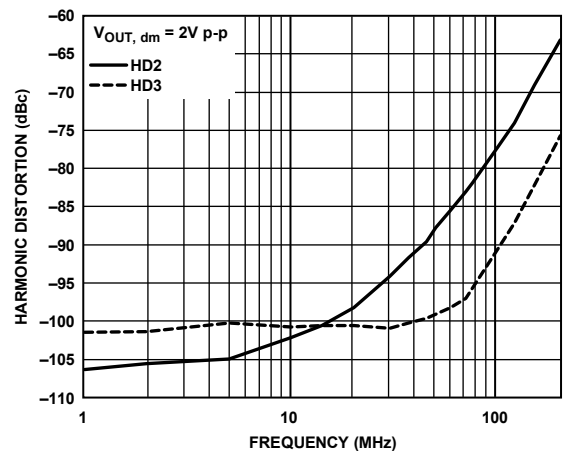

Figure 3. Harmonic Distortion vs. Frequency

TABLE OF CONTENTS

Features	1	Theory of Operation	17
Applications.....	1	Analyzing an Application Circuit	17
General Description	1	Setting the Closed-Loop Gain	17
Functional Block Diagrams.....	1	Stable for Gains ≥ 2	17
Revision History	2	Estimating the Output Noise Voltage	17
Specifications.....	3	Impact of Mismatches in the Feedback Networks.....	18
5 V Operation	3	Calculating the Input Impedance for an Application Circuit	19
3.3 V Operation	5	Input Common-Mode Voltage Range.....	21
Absolute Maximum Ratings.....	7	Input and Output Capacitive AC Coupling.....	21
Thermal Resistance	7	Minimum R_G Value of 50Ω	21
Maximum Power Dissipation	7	Setting the Output Common-Mode Voltage.....	21
ESD Caution.....	7	Layout, Grounding, and Bypassing.....	22
Pin Configurations and Function Descriptions	8	High Performance ADC Driving	23
Typical Performance Characteristics	9	Outline Dimensions	24
Test Circuits.....	15	Ordering Guide	24
Operational Description.....	16		
Definition of Terms.....	16		

REVISION HISTORY

5/2016—Rev. 0 to Rev. A

Changed ADA4939 to ADA4939-1/ADA4939-2, CP-16-2 to CP-16-21, and CP-24-1 to CP-24-10.....	Throughout
Changes to Figure 5, Figure 6, Table 9, and Table 10.....	8
Changes to Figure 54.....	23
Updated Outline Dimensions	24
Changes to Ordering Guide	24

5/2008—Revision 0: Initial Version

SPECIFICATIONS

5 V OPERATION

$T_A = 25^\circ\text{C}$, $+V_S = 5\text{ V}$, $-V_S = 0\text{ V}$, $V_{OCM} = +V_S/2$, $R_F = 402\ \Omega$, $R_G = 200\ \Omega$, $R_T = 60.4\ \Omega$ (when used), $R_{L, dm} = 1\ \text{k}\Omega$, unless otherwise noted. All specifications refer to single-ended input and differential outputs, unless otherwise noted. Refer to Figure 42 for signal definitions.

$\pm D_{IN}$ to $V_{OUT, dm}$ Performance

Table 1.

Parameter	Test Conditions/Comments	Min	Typ	Max	Unit
DYNAMIC PERFORMANCE					
-3 dB Small Signal Bandwidth	$V_{OUT, dm} = 0.1\text{ V p-p}$		1400		MHz
Bandwidth for 0.1 dB Flatness	$V_{OUT, dm} = 0.1\text{ V p-p}$, ADA4939-1		300		MHz
	$V_{OUT, dm} = 0.1\text{ V p-p}$, ADA4939-2		90		MHz
Large Signal Bandwidth	$V_{OUT, dm} = 2\text{ V p-p}$		1400		MHz
Slew Rate	$V_{OUT, dm} = 2\text{ V p-p}$, 25% to 75%		6800		V/ μs
Overdrive Recovery Time	$V_{IN} = 0\text{ V}$ to 1.5 V step, $G = 3.16$		<1		ns
NOISE/HARMONIC PERFORMANCE					
See Figure 41 for distortion test circuit					
Second Harmonic	$V_{OUT, dm} = 2\text{ V p-p}$, 10 MHz		-102		dBc
	$V_{OUT, dm} = 2\text{ V p-p}$, 70 MHz		-83		dBc
	$V_{OUT, dm} = 2\text{ V p-p}$, 100 MHz		-77		dBc
Third Harmonic	$V_{OUT, dm} = 2\text{ V p-p}$, 10 MHz		-101		dBc
	$V_{OUT, dm} = 2\text{ V p-p}$, 70 MHz		-97		dBc
	$V_{OUT, dm} = 2\text{ V p-p}$, 100 MHz		-91		dBc
IMD	$f_1 = 70\text{ MHz}$, $f_2 = 70.1\text{ MHz}$, $V_{OUT, dm} = 2\text{ V p-p}$		-95		dBc
	$f_1 = 140\text{ MHz}$, $f_2 = 140.1\text{ MHz}$, $V_{OUT, dm} = 2\text{ V p-p}$		-89		dBc
Voltage Noise (RTI)	$f = 100\text{ kHz}$		2.3		nV/ $\sqrt{\text{Hz}}$
Input Current Noise	$f = 100\text{ kHz}$		6		pA/ $\sqrt{\text{Hz}}$
Crosstalk	$f = 100\text{ MHz}$, ADA4939-2		-80		dB
INPUT CHARACTERISTICS					
Offset Voltage	$V_{OS, dm} = V_{OUT, dm}/2$, $V_{DIN+} = V_{DIN-} = 2.5\text{ V}$ T_{MIN} to T_{MAX} variation	-3.4	± 0.5	+2.8	mV $\mu\text{V}/^\circ\text{C}$
Input Bias Current	T_{MIN} to T_{MAX} variation	-26	-10	+2.2	μA $\mu\text{A}/^\circ\text{C}$
Input Offset Current		-11.2	+0.5	+11.2	μA
Input Resistance	Differential		180		k Ω
	Common mode		450		k Ω
Input Capacitance			1		pF
Input Common-Mode Voltage		1.1		3.9	V
CMRR	$\Delta V_{OUT, dm}/\Delta V_{IN, cm}$, $\Delta V_{IN, cm} = \pm 1\text{ V}$		-83	-77	dB
OUTPUT CHARACTERISTICS					
Output Voltage Swing	Maximum ΔV_{OUT} , single-ended output, $R_F = R_G = 10\ \text{k}\Omega$	0.9		4.1	V
Linear Output Current			100		mA
Output Balance Error	$\Delta V_{OUT, cm}/\Delta V_{OUT, dm}$, $\Delta V_{OUT, dm} = 1\text{ V}$, 10 MHz, see Figure 40 for test circuit		-64		dB

V_{OCM} to V_{OUT,cm} Performance

Table 2.

Parameter	Test Conditions/Comments	Min	Typ	Max	Unit
V_{OCM} DYNAMIC PERFORMANCE					
-3 dB Bandwidth			670		MHz
Slew Rate	V _{IN} = 1.5 V to 3.5 V, 25% to 75%		2500		V/μs
Input Voltage Noise (RTI)	f = 100 kHz		7.5		nV/√Hz
V_{OCM} INPUT CHARACTERISTICS					
Input Voltage Range		1.3		3.5	V
Input Resistance		8.3	9.7	11.5	kΩ
Input Offset Voltage	V _{OS,cm} = V _{OUT,cm} , V _{DIN+} = V _{DIN-} = +V _S /2	-3.7	±0.5	+3.7	mV
V _{OCM} CMRR	ΔV _{OUT,dm} /ΔV _{OCM} , ΔV _{OCM} = ±1 V		-90	-73	dB
Gain	ΔV _{OUT,cm} /ΔV _{OCM} , ΔV _{OCM} = ±1 V	0.97	0.98	0.99	V/V

General Performance

Table 3.

Parameter	Test Conditions/Comments	Min	Typ	Max	Unit
POWER SUPPLY					
Operating Range		3.0		5.25	V
Quiescent Current per Amplifier		35.1	36.5	37.7	mA
	T _{MIN} to T _{MAX} variation		16		μA/°C
	Powered down	0.26	0.32	0.38	mA
Power Supply Rejection Ratio	ΔV _{OUT,dm} /ΔV _S , ΔV _S = 1 V		-90	-80	dB
POWER-DOWN ($\overline{\text{PD}}$)					
$\overline{\text{PD}}$ Input Voltage	Powered down		≤1		V
	Enabled		≥2		V
Turn-Off Time			500		ns
Turn-On Time			100		ns
$\overline{\text{PD}}$ Pin Bias Current per Amplifier					
Enabled	$\overline{\text{PD}}$ = 5 V		30		μA
Disabled	$\overline{\text{PD}}$ = 0 V		-200		μA
OPERATING TEMPERATURE RANGE		-40		+105	°C

3.3 V OPERATION

$T_A = 25^\circ\text{C}$, $+V_S = 3.3\text{ V}$, $-V_S = 0\text{ V}$, $V_{\text{OCM}} = +V_S/2$, $R_F = 402\ \Omega$, $R_G = 200\ \Omega$, $R_T = 60.4\ \Omega$ (when used), $R_{L,\text{dm}} = 1\ \text{k}\Omega$, unless otherwise noted. All specifications refer to single-ended input and differential outputs, unless otherwise noted. Refer to Figure 42 for signal definitions.

$\pm D_{\text{IN}}$ to $V_{\text{OUT, dm}}$ Performance

Table 4.

Parameter	Test Conditions/Comments	Min	Typ	Max	Unit
DYNAMIC PERFORMANCE					
–3 dB Small Signal Bandwidth	$V_{\text{OUT, dm}} = 0.1\text{ V p-p}$		1400		MHz
Bandwidth for 0.1 dB Flatness	$V_{\text{OUT, dm}} = 0.1\text{ V p-p}$, ADA4939-1		300		MHz
	$V_{\text{OUT, dm}} = 0.1\text{ V p-p}$, ADA4939-2		90		MHz
Large Signal Bandwidth	$V_{\text{OUT, dm}} = 2\text{ V p-p}$		1400		MHz
Slew Rate	$V_{\text{OUT, dm}} = 2\text{ V p-p}$, 25% to 75%		5000		V/ μs
Overdrive Recovery Time	$V_{\text{IN}} = 0\text{ V}$ to 1.0 V step, $G = 3.16$		<1		ns
NOISE/HARMONIC PERFORMANCE					
See Figure 41 for distortion test circuit					
Second Harmonic	$V_{\text{OUT, dm}} = 2\text{ V p-p}$, 10 MHz		–100		dBc
	$V_{\text{OUT, dm}} = 2\text{ V p-p}$, 70 MHz		–90		dBc
	$V_{\text{OUT, dm}} = 2\text{ V p-p}$, 100 MHz		–83		dBc
Third Harmonic	$V_{\text{OUT, dm}} = 2\text{ V p-p}$, 10 MHz		–94		dBc
	$V_{\text{OUT, dm}} = 2\text{ V p-p}$, 70 MHz		–82		dBc
	$V_{\text{OUT, dm}} = 2\text{ V p-p}$, 100 MHz		–75		dBc
IMD	$f_1 = 70\text{ MHz}$, $f_2 = 70.1\text{ MHz}$, $V_{\text{OUT, dm}} = 2\text{ V p-p}$		–87		dBc
	$f_1 = 140\text{ MHz}$, $f_2 = 140.1\text{ MHz}$, $V_{\text{OUT, dm}} = 2\text{ V p-p}$		–70		dBc
Voltage Noise (RTI)	$f = 100\text{ kHz}$		2.3		nV/ $\sqrt{\text{Hz}}$
Input Current Noise	$f = 100\text{ kHz}$		6		pA/ $\sqrt{\text{Hz}}$
Crosstalk	$f = 100\text{ MHz}$, ADA4939-2		–80		dB
INPUT CHARACTERISTICS					
Offset Voltage	$V_{\text{OS, dm}} = V_{\text{OUT, dm}}/2$, $V_{\text{DIN+}} = V_{\text{DIN-}} = +V_S/2$ T_{MIN} to T_{MAX} variation	–3.5	± 0.5	+3.5	mV $\mu\text{V}/^\circ\text{C}$
Input Bias Current	T_{MIN} to T_{MAX} variation	–26	–10	+2.2	μA $\mu\text{A}/^\circ\text{C}$
Input Offset Current		–11.2	± 0.4	+11.2	
Input Resistance	Differential		180		k Ω
	Common mode		450		k Ω
Input Capacitance			1		pF
Input Common-Mode Voltage		0.9		2.4	V
CMRR	$\Delta V_{\text{OUT, dm}}/\Delta V_{\text{IN, cm}}$, $\Delta V_{\text{IN, cm}} = \pm 1\text{ V}$		–85	–75	dB
OUTPUT CHARACTERISTICS					
Output Voltage Swing	Maximum ΔV_{OUT} , single-ended output, $R_F = R_G = 10\ \text{k}\Omega$	0.8		2.5	V
Linear Output Current			75		mA
Output Balance Error	$\Delta V_{\text{OUT, cm}}/\Delta V_{\text{OUT, dm}}$, $\Delta V_{\text{OUT, dm}} = 1\text{ V}$, $f = 10\text{ MHz}$, see Figure 40 for test circuit		–61		dB

V_{OCM} to V_{OUT,cm} Performance

Table 5.

Parameter	Test Conditions/Comments	Min	Typ	Max	Unit
V_{OCM} DYNAMIC PERFORMANCE					
-3 dB Bandwidth			560		MHz
Slew Rate	V _{IN} = 0.9 V to 2.4 V, 25% to 75%		1250		V/μs
Input Voltage Noise (RTI)	f = 100 kHz		7.5		nV/√Hz
V_{OCM} INPUT CHARACTERISTICS					
Input Voltage Range		1.3		1.9	V
Input Resistance		8.3	9.7	11.2	kΩ
Input Offset Voltage	V _{OS,cm} = V _{OUT,cm} , V _{DIN+} = V _{DIN-} = 1.67 V	-3.7	±0.5	+3.7	mV
V _{OCM} CMRR	ΔV _{OUT,dm} /ΔV _{OCM,r} , ΔV _{OCM} = ±1 V		-75	-73	dB
Gain	ΔV _{OUT,cm} /ΔV _{OCM,r} , ΔV _{OCM} = ±1 V	0.97	0.98	0.99	V/V

General Performance

Table 6.

Parameter	Test Conditions/Comments	Min	Typ	Max	Unit
POWER SUPPLY					
Operating Range		3.0		5.25	V
Quiescent Current per Amplifier	T _{MIN} to T _{MAX} variation	32.8	34.5	36.0	mA
	Powered down	0.16	0.20	0.26	mA
Power Supply Rejection Ratio	ΔV _{OUT,dm} /ΔV _S , ΔV _S = 1 V		-84	-72	dB
POWER-DOWN (PD)					
PD Input Voltage	Powered down		≤1		V
	Enabled		≥2		V
Turn-Off Time			500		ns
Turn-On Time			100		ns
PD Pin Bias Current per Amplifier					
Enabled	PD = 3.3 V		26		μA
Disabled	PD = 0 V		-137		μA
OPERATING TEMPERATURE RANGE					
		-40		+105	°C

ABSOLUTE MAXIMUM RATINGS

Table 7.

Parameter	Rating
Supply Voltage	5.5 V
Power Dissipation	See Figure 4
Input Current, +IN, -IN, \overline{PD}	± 5 mA
Storage Temperature Range	-65°C to +125°C
Operating Temperature Range	
ADA4939-1	-40°C to +105°C
ADA4939-2	-40°C to +105°C
Lead Temperature (Soldering, 10 sec)	300°C
Junction Temperature	150°C

Stresses at or above those listed under Absolute Maximum Ratings may cause permanent damage to the product. This is a stress rating only; functional operation of the product at these or any other conditions above those indicated in the operational section of this specification is not implied. Operation beyond the maximum operating conditions for extended periods may affect product reliability.

THERMAL RESISTANCE

θ_{JA} is specified for the device (including exposed pad) soldered to a high thermal conductivity 2s2p circuit board, as described in EIA/JESD 51-7.

Table 8. Thermal Resistance

Package Type	θ_{JA}	Unit
ADA4939-1, 16-Lead LFCSP (Exposed Pad)	98	°C/W
ADA4939-2, 24-Lead LFCSP (Exposed Pad)	67	°C/W

MAXIMUM POWER DISSIPATION

The maximum safe power dissipation for the ADA4939-1/ADA4939-2 package is limited by the associated rise in junction temperature (T_J) on the die. At approximately 150°C, which is the glass transition temperature, the plastic changes its properties. Even temporarily exceeding this temperature limit can change the stresses that the package exerts on the die, permanently shifting the parametric performance of the ADA4939-1/ADA4939-2. Exceeding a junction temperature of 150°C for an extended period can result in changes in the silicon devices, potentially causing failure.

The power dissipated in the package (P_D) is the sum of the quiescent power dissipation and the power dissipated in the package due to the load drive. The quiescent power is the voltage between the supply pins (V_S) times the quiescent current (I_S). The power dissipated due to the load drive depends upon the particular application. Calculate the power due to the load drive by multiplying the load current by the associated voltage drop across the device. RMS voltages and currents must be used in these calculations.

Airflow increases heat dissipation, effectively reducing θ_{JA} . In addition, more metal directly in contact with the package leads/exposed pad from metal traces, through holes, ground, and power planes reduces θ_{JA} .

Figure 4 shows the maximum safe power dissipation in the package vs. the ambient temperature for the single 16-lead LFCSP (98°C/W) and the dual 24-lead LFCSP (67°C/W) on a JEDEC standard 4-layer board with the exposed pad soldered to a PCB pad that is connected to a solid plane.

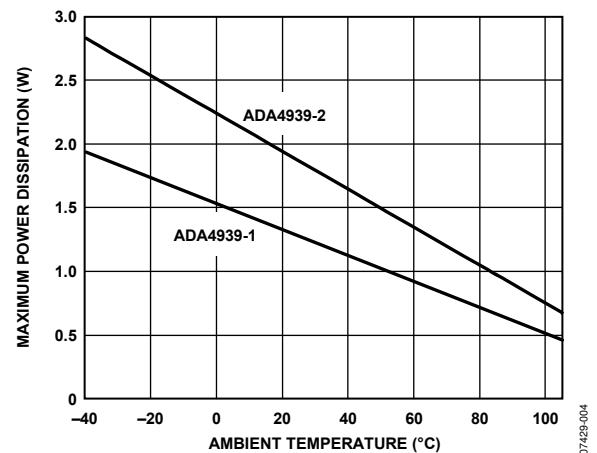

Figure 4. Maximum Power Dissipation vs. Ambient Temperature for a 4-Layer Board

ESD CAUTION



ESD (electrostatic discharge) sensitive device. Charged devices and circuit boards can discharge without detection. Although this product features patented or proprietary protection circuitry, damage may occur on devices subjected to high energy ESD. Therefore, proper ESD precautions should be taken to avoid performance degradation or loss of functionality.

PIN CONFIGURATIONS AND FUNCTION DESCRIPTIONS

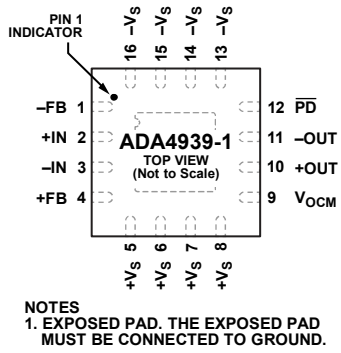

Figure 5. ADA4939-1 Pin Configuration

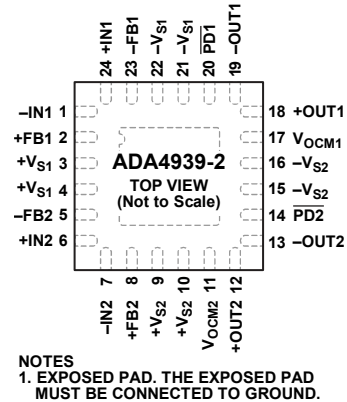

Figure 6. ADA4939-2 Pin Configuration

Table 9. ADA4939-1 Pin Function Descriptions

Pin No.	Mnemonic	Description
1	-FB	Negative Output for Feedback Component Connection
2	+IN	Positive Input Summing Node
3	-IN	Negative Input Summing Node
4	+FB	Positive Output for Feedback Component Connection
5 to 8	+Vs	Positive Supply Voltage
9	V _{OCM}	Output Common-Mode Voltage
10	+OUT	Positive Output for Load Connection
11	-OUT	Negative Output for Load Connection
12	PD	Power-Down Pin
13 to 16	-Vs	Negative Supply Voltage
	EPAD	Exposed Pad. The exposed pad must be connected to ground.

Table 10. ADA4939-2 Pin Function Descriptions

Pin No.	Mnemonic	Description
1	-IN1	Negative Input Summing Node 1
2	+FB1	Positive Output Feedback 1
3, 4	+Vs1	Positive Supply Voltage 1
5	-FB2	Negative Output Feedback 2
6	+IN2	Positive Input Summing Node 2
7	-IN2	Negative Input Summing Node 2
8	+FB2	Positive Output Feedback 2
9, 10	+Vs2	Positive Supply Voltage 2
11	V _{OCM2}	Output Common-Mode Voltage 2
12	+OUT2	Positive Output 2
13	-OUT2	Negative Output 2
14	PD2	Power-Down Pin 2
15, 16	-Vs2	Negative Supply Voltage 2
17	V _{OCM1}	Output Common-Mode Voltage 1
18	+OUT1	Positive Output 1
19	-OUT1	Negative Output 1
20	PD1	Power-Down Pin 1
21, 22	-Vs1	Negative Supply Voltage 1
23	-FB1	Negative Output Feedback 1
24	+IN1	Positive Input Summing Node 1
	EPAD	Exposed Pad. The exposed pad must be connected to ground.

TYPICAL PERFORMANCE CHARACTERISTICS

$T_A = 25^\circ\text{C}$, $+V_S = 5\text{ V}$, $-V_S = 0\text{ V}$, $V_{\text{OCM}} = +V_S / 2$, $R_G = 200\ \Omega$, $R_F = 402\ \Omega$, $R_T = 60.4\ \Omega$, $G = 1$, $R_{L, \text{dm}} = 1\ \text{k}\Omega$, unless otherwise noted. Refer to Figure 39 for test setup. Refer to Figure 42 for signal definitions.

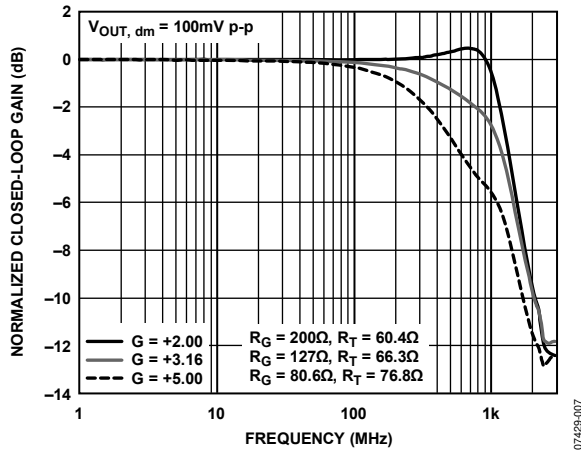

Figure 7. Small Signal Frequency Response for Various Gains

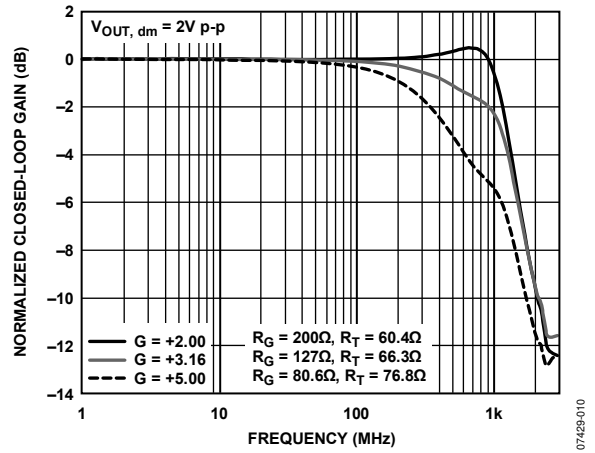

Figure 10. Large Signal Frequency Response for Various Gains

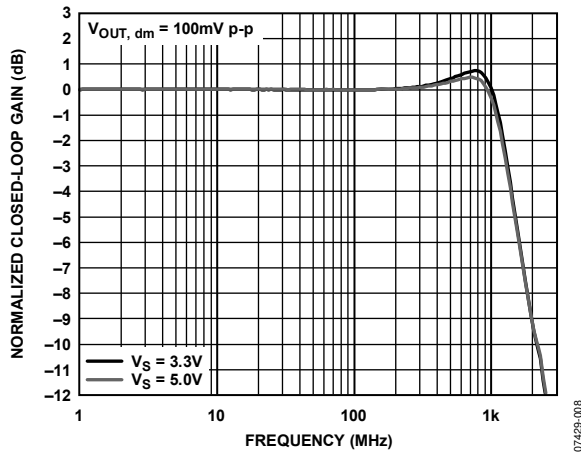

Figure 8. Small Signal Frequency Response for Various Supplies

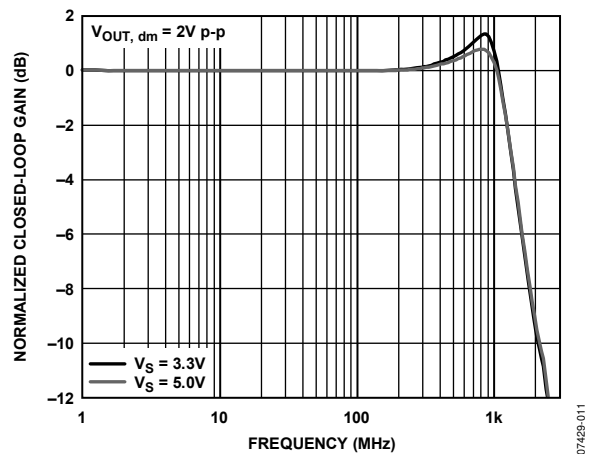

Figure 11. Large Signal Frequency Response for Various Supplies

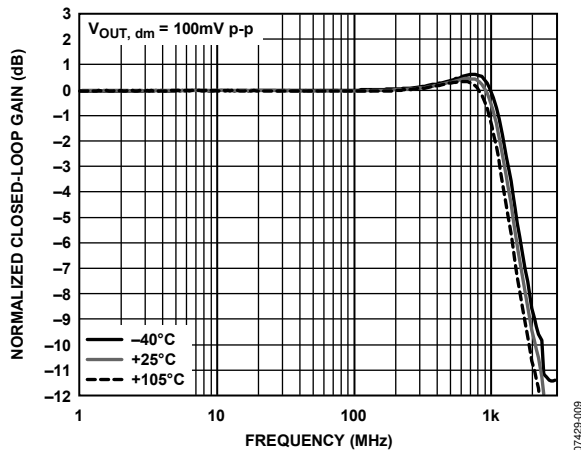

Figure 9. Small Signal Frequency Response for Various Temperatures

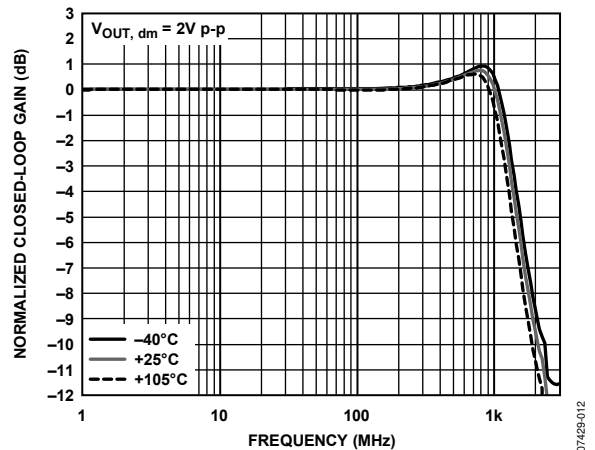

Figure 12. Large Signal Frequency Response for Various Temperatures

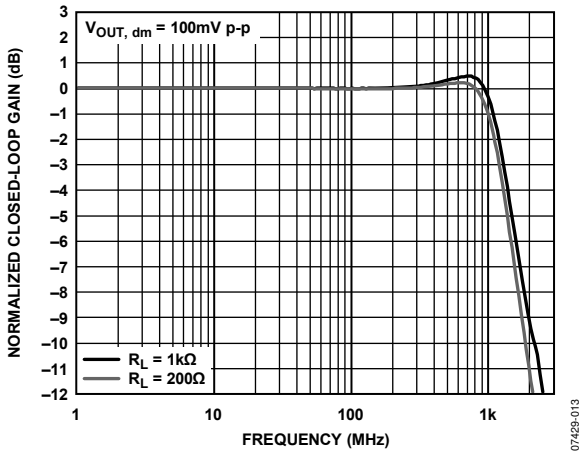

Figure 13. Small Signal Frequency Response for Various Loads

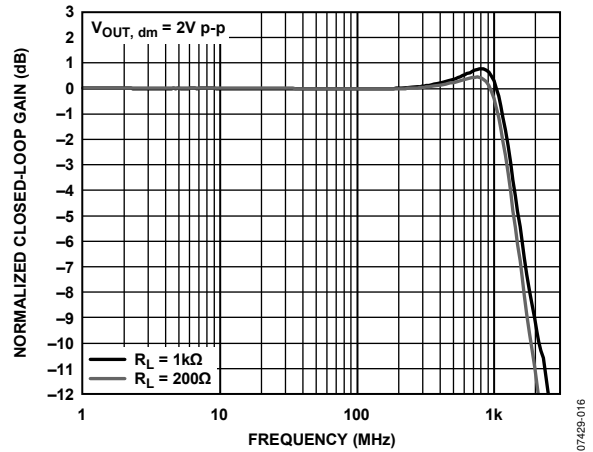

Figure 16. Large Signal Frequency Response for Various Loads

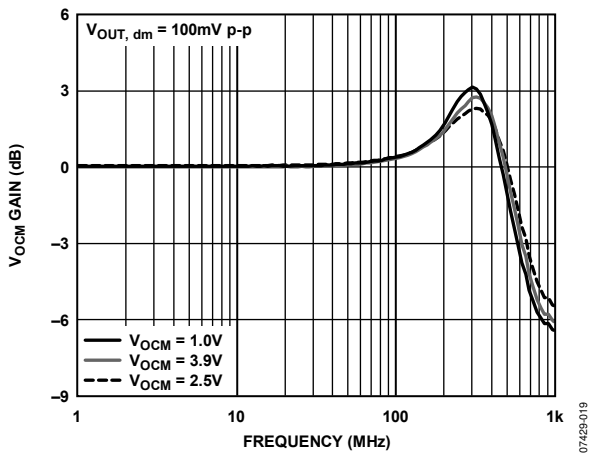

Figure 14. V_{OCM} Small Signal Frequency Response at Various DC Levels

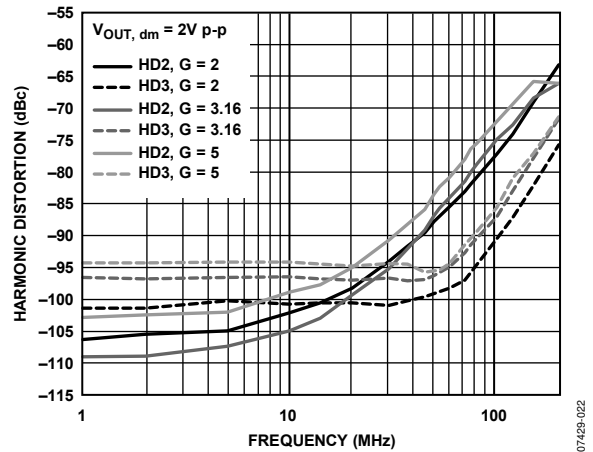

Figure 17. Harmonic Distortion vs. Frequency at Various Gains

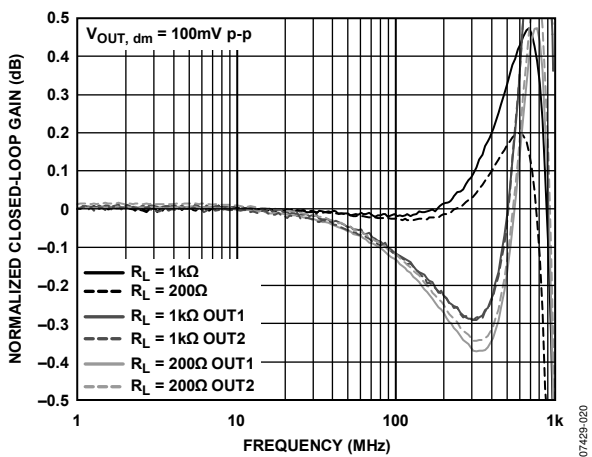

Figure 15. 0.1 dB Flatness Small Signal Response for Various Loads

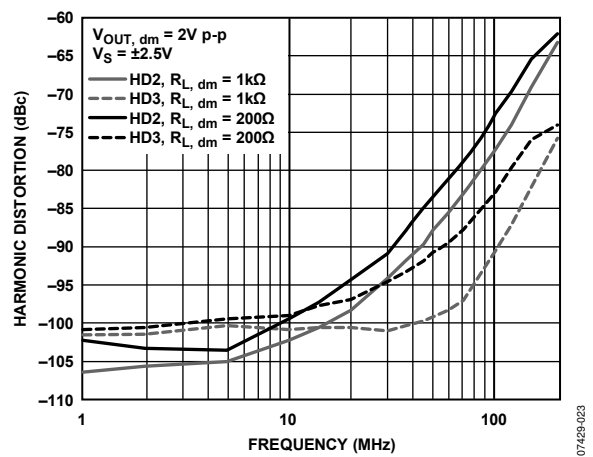

Figure 18. Harmonic Distortion vs. Frequency at Various Loads

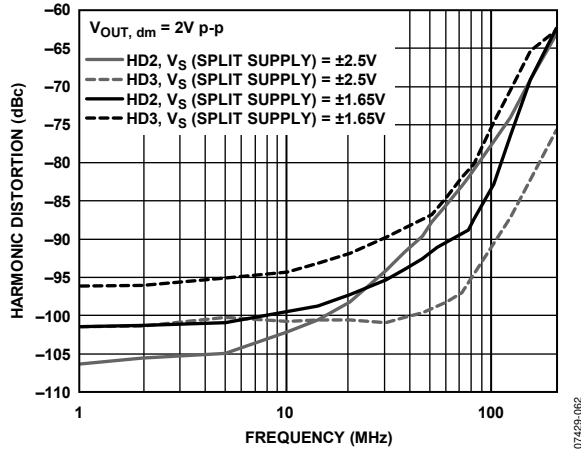

Figure 19. Harmonic Distortion vs. Frequency at Various Supplies

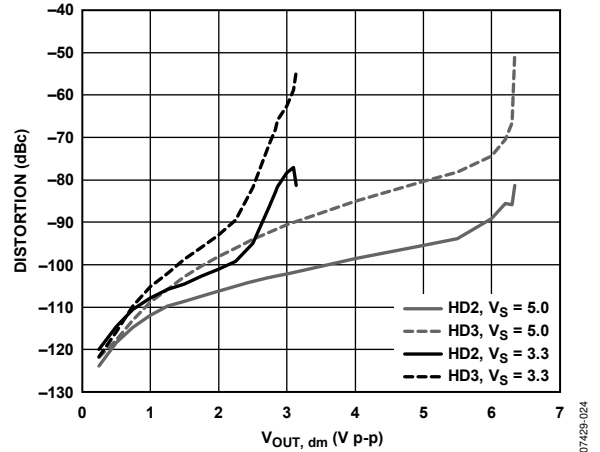

Figure 22. Harmonic Distortion vs. $V_{OUT,dm}$ and Supply Voltage, $f = 10\text{ MHz}$

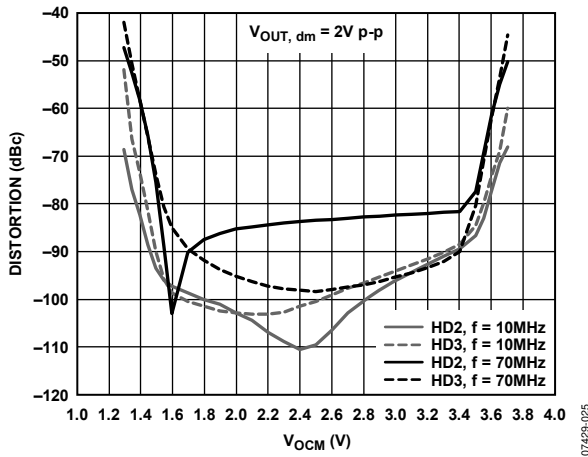

Figure 20. Harmonic Distortion vs. V_{OCM} at Various Frequencies

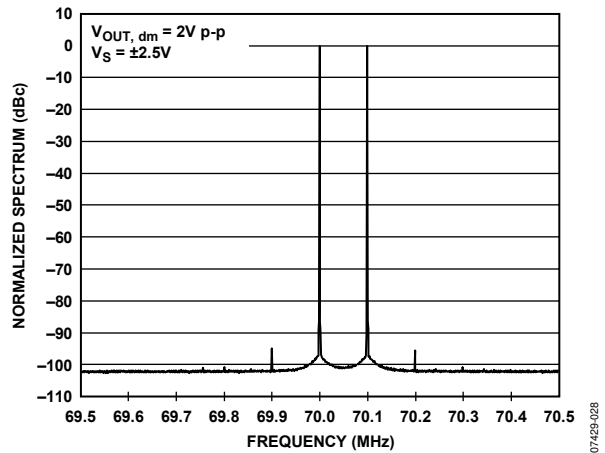

Figure 23. 70 MHz Intermodulation Distortion

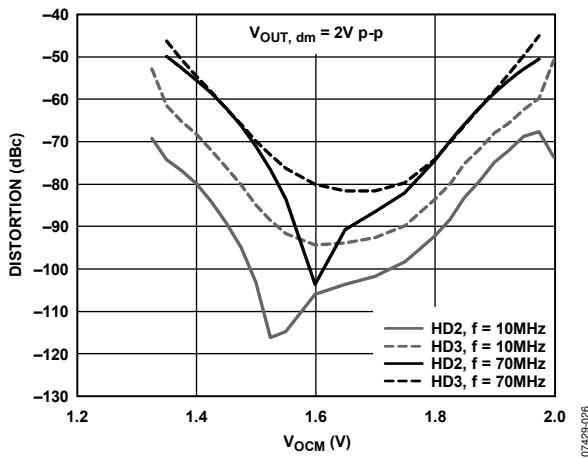

Figure 21. Harmonic Distortion vs. V_{OCM} at Various Frequencies

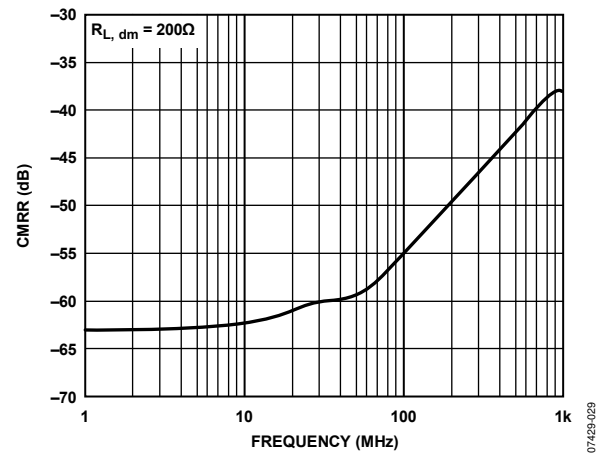

Figure 24. CMRR vs. Frequency

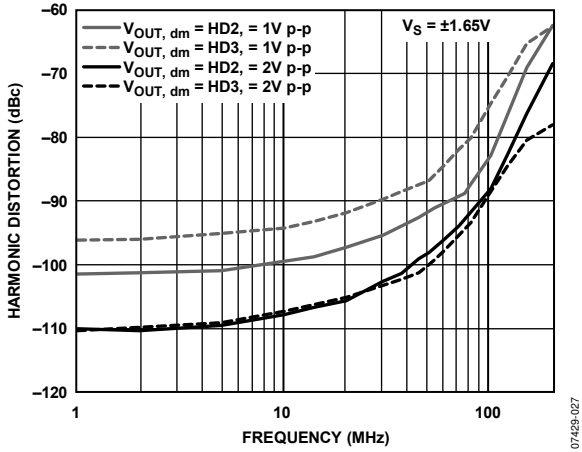

Figure 25. Harmonic Distortion vs. Frequency at Various Output Voltages

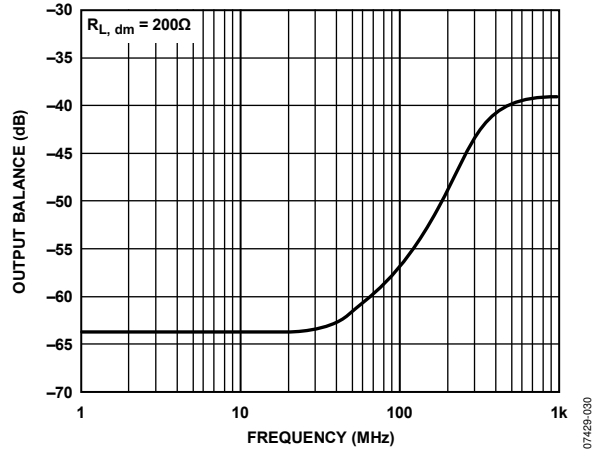

Figure 28. Output Balance vs. Frequency

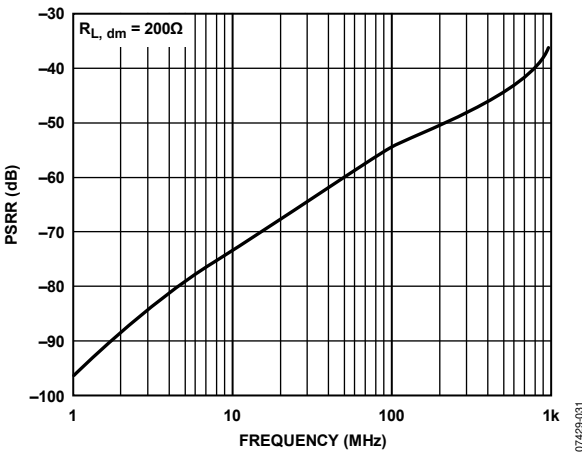

Figure 26. PSRR vs. Frequency, $R_L = 200\ \Omega$

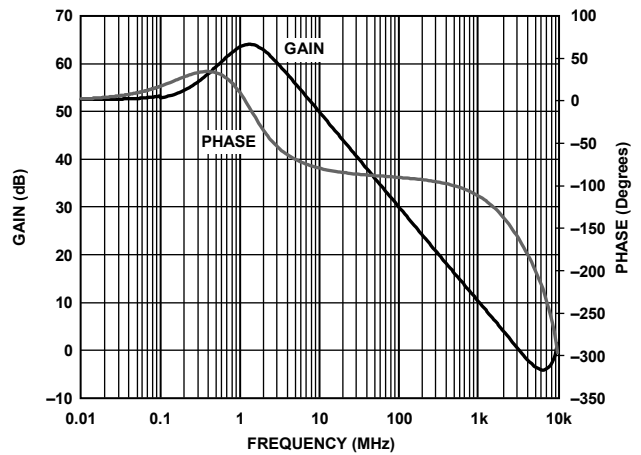

Figure 29. Open-Loop Gain and Phase vs. Frequency

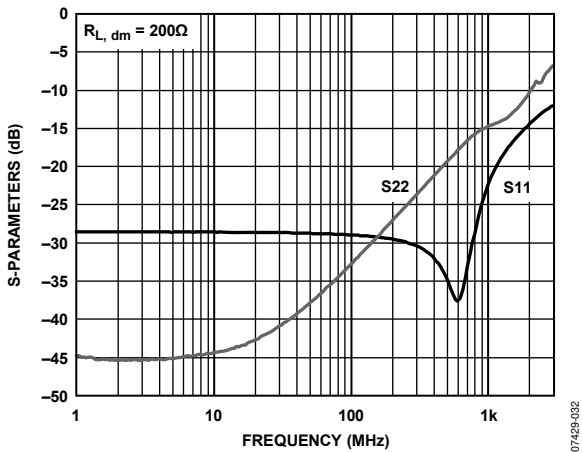

Figure 27. Return Loss (S11, S22) vs. Frequency

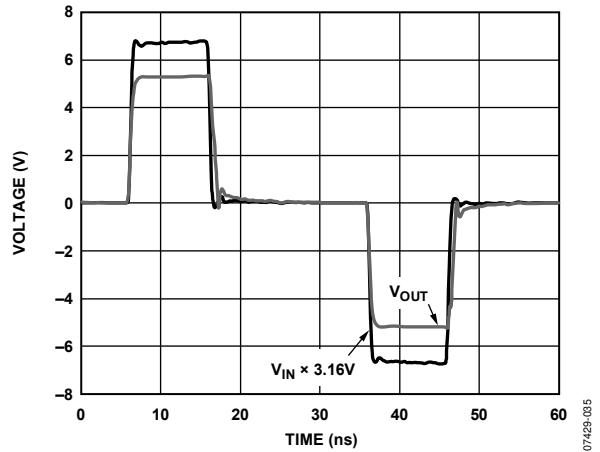

Figure 30. Overdrive Recovery, $G = 3.16$

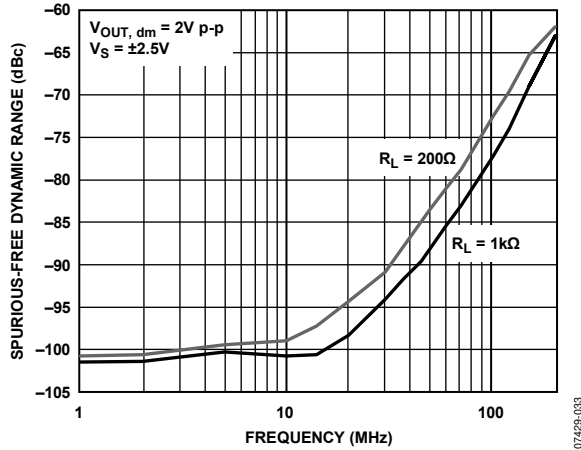

Figure 31. Spurious-Free Dynamic Range vs. Frequency at Various Loads

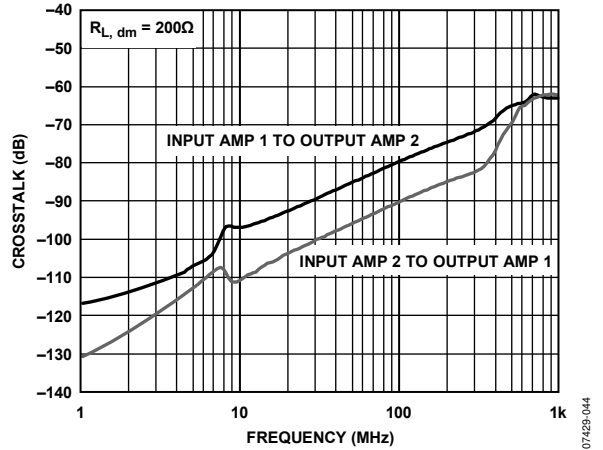

Figure 34. Crosstalk vs. Frequency for ADA4939-2

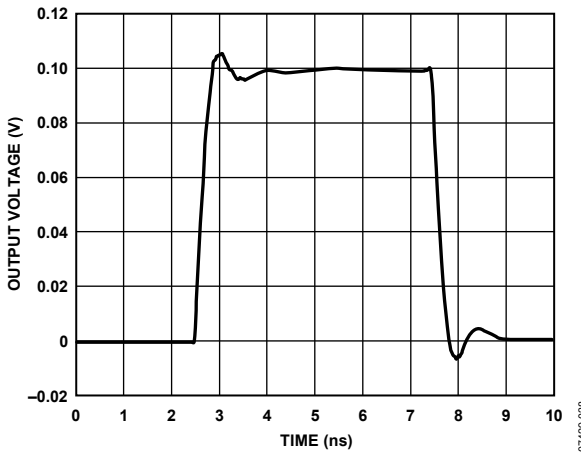

Figure 32. Small Signal Pulse Response

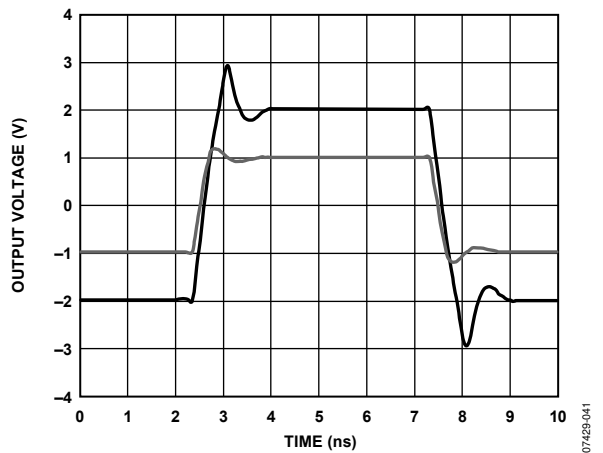

Figure 35. Large Signal Pulse Response

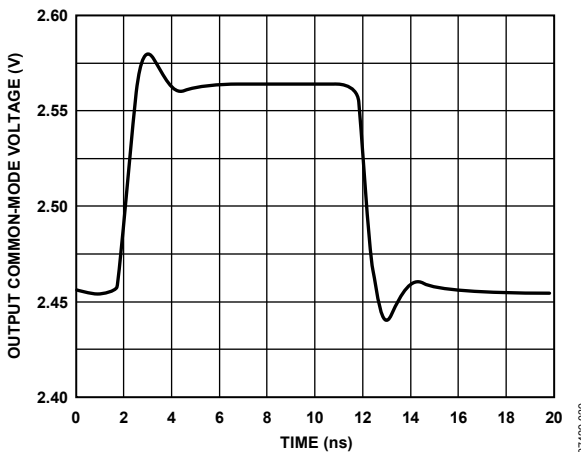

Figure 33. V_{OCM} Small Signal Pulse Response

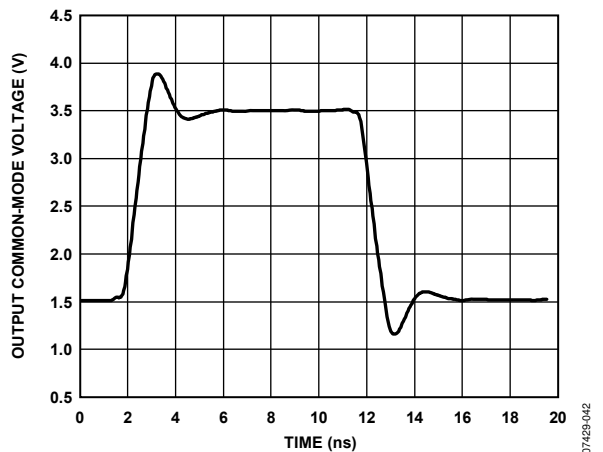

Figure 36. V_{OCM} Large Signal Pulse Response

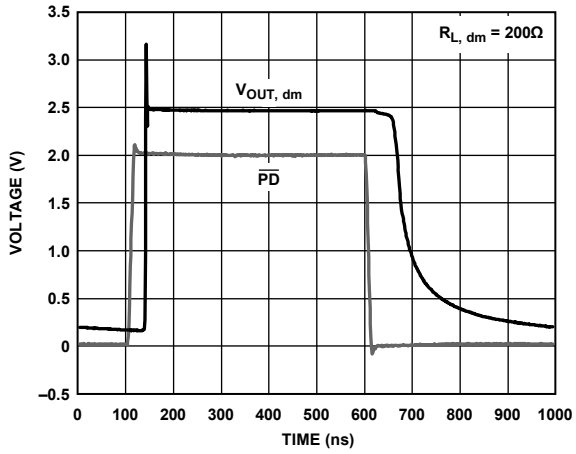

Figure 37. \overline{PD} Response Time

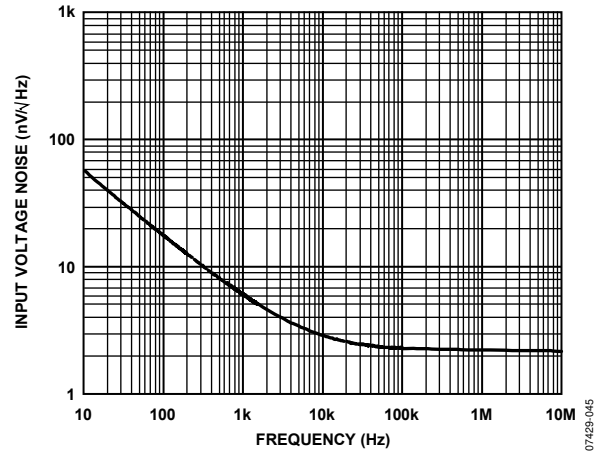

Figure 38. Voltage Noise Spectral Density, RTI

TEST CIRCUITS

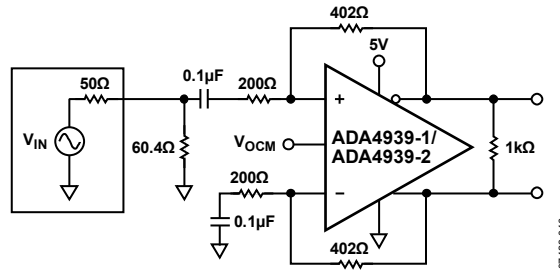

Figure 39. Equivalent Basic Test Circuit, $G = 2$

07429-046

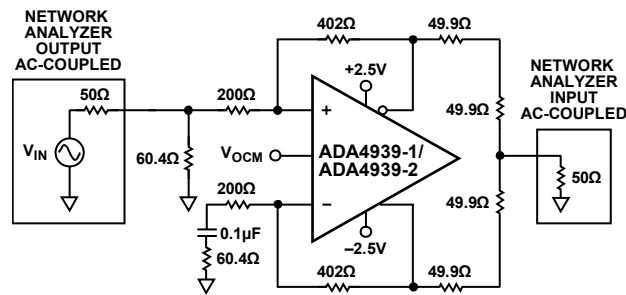

Figure 40. Test Circuit for Output Balance, CMRR

07429-047

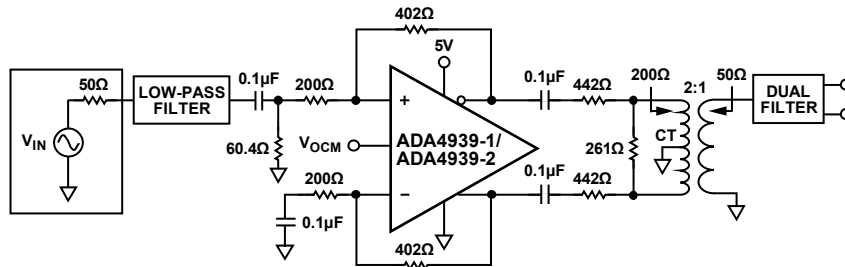

Figure 41. Test Circuit for Distortion Measurements

07429-048

OPERATIONAL DESCRIPTION

DEFINITION OF TERMS

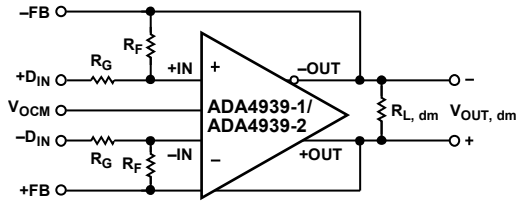

Figure 42. Circuit Definitions

07429-049

Differential Voltage

Differential voltage refers to the difference between two node voltages. For example, the output differential voltage (or equivalently, output differential-mode voltage) is defined as

$$V_{OUT, dm} = (V_{+OUT} - V_{-OUT})$$

where V_{+OUT} and V_{-OUT} refer to the voltages at the +OUT and -OUT terminals with respect to a common reference.

Common-Mode Voltage

Common-mode voltage refers to the average of two node voltages. The output common-mode voltage is defined as

$$V_{OUT, cm} = (V_{+OUT} + V_{-OUT})/2$$

Balance

Output balance is a measure of how close the differential signals are to being equal in amplitude and opposite in phase. Output balance is most easily determined by placing a well-matched resistor divider between the differential voltage nodes and comparing the magnitude of the signal at the divider midpoint with the magnitude of the differential signal (see Figure 39). By this definition, output balance is the magnitude of the output common-mode voltage divided by the magnitude of the output differential mode voltage.

$$Output\ Balance\ Error = \left| \frac{V_{OUT, cm}}{V_{OUT, dm}} \right|$$

THEORY OF OPERATION

The ADA4939-1/ADA4939-2 differ from conventional op amps in that they have two outputs whose voltages move in opposite directions and an additional input, V_{OCM} . Like op amps, they rely on high open-loop gain and negative feedback to force these outputs to the desired voltages. The ADA4939-1/ADA4939-2 behave much like standard voltage feedback op amps and facilitate single-ended-to-differential conversions, common-mode level shifting, and amplifications of differential signals. Like op amps, the ADA4939-1/ADA4939-2 have high input impedance and low output impedance. Because they use voltage feedback, the ADA4939-1/ADA4939-2 manifest a nominally constant gain-bandwidth product.

Two feedback loops are employed to control the differential and common-mode output voltages. The differential feedback, set with external resistors, controls only the differential output voltage. The common-mode feedback controls only the common-mode output voltage. This architecture makes it easy to set the output common-mode level to any arbitrary value within the specified limits. The output common-mode voltage is forced by the internal common-mode feedback loop to be equal to the voltage applied to the V_{OCM} input.

The internal common-mode feedback loop produces outputs that are highly balanced over a wide frequency range without requiring tightly matched external components. This results in differential outputs that are very close to the ideal of being identical in amplitude and are exactly 180° apart in phase.

ANALYZING AN APPLICATION CIRCUIT

The ADA4939-1/ADA4939-2 use high open-loop gain and negative feedback to force their differential and common-mode output voltages in such a way as to minimize the differential and common-mode error voltages. The differential error voltage is defined as the voltage between the differential inputs labeled +IN and -IN (see Figure 42). For most purposes, this voltage is zero. Similarly, the difference between the actual output common-mode voltage and the voltage applied to V_{OCM} is also zero. Starting from these two assumptions, any application circuit can be analyzed.

SETTING THE CLOSED-LOOP GAIN

The differential-mode gain of the circuit in Figure 42 can be determined by

$$\left| \frac{V_{OUT, dm}}{V_{IN, dm}} \right| = \frac{R_F}{R_G}$$

This presumes that the input resistors (R_G) and feedback resistors (R_F) on each side are equal.

STABLE FOR GAINS ≥ 2

The ADA4939-1/ADA4939-2 frequency response exhibits excessive peaking for differential gains < 2 ; therefore, operate the device with differential gains ≥ 2 .

ESTIMATING THE OUTPUT NOISE VOLTAGE

To estimate the differential output noise of the ADA4939-1/ADA4939-2 use the noise model shown in Figure 43. The input-referred noise voltage density, v_{nIN} , is modeled as a differential input, and the noise currents, i_{nIN-} and i_{nIN+} , appear between each input and ground. The output voltage due to v_{nIN} is obtained by multiplying v_{nIN} by the noise gain, G_N (defined in the G_N equation that follows). The noise currents are uncorrelated with the same mean-square value, and each produces an output voltage that is equal to the noise current multiplied by the associated feedback resistance. The noise voltage density at the V_{OCM}/V_{OCMx} pin is v_{nCM} . When the feedback networks have the same feedback factor, as in most cases, the output noise due to v_{nCM} is common-mode. Each of the four resistors contributes $(4kTR_{xx})^{1/2}$. The noise from the feedback resistors appears directly at the output, and the noise from the gain resistors appears at the output multiplied by R_F/R_G . Table 11 summarizes the input noise sources, the multiplication factors, and the output-referred noise density terms.

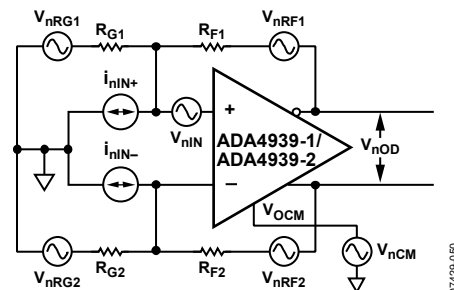

Figure 43. Noise Model

07429-010

Table 11. Output Noise Voltage Density Calculations for Matched Feedback Networks

Input Noise Contribution	Input Noise Term	Input Noise Voltage Density	Output Multiplication Factor	Differential Output Noise Voltage Density Term
Differential Input	V_{nIN}	V_{nIN}	G_N	$V_{nO1} = G_N(V_{nIN})$
Inverting Input	i_{nIN}	$i_{nIN} \times (R_{F2})$	1	$V_{nO2} = (i_{nIN})(R_{F2})$
Noninverting Input	i_{nIN}	$i_{nIN} \times (R_{F1})$	1	$V_{nO3} = (i_{nIN})(R_{F1})$
V_{OCM} Input	V_{nCM}	V_{nCM}	0	$V_{nO4} = 0$
Gain Resistor R_{G1}	V_{nRG1}	$(4kTR_{G1})^{1/2}$	R_{F1}/R_{G1}	$V_{nO5} = (R_{F1}/R_{G1})(4kTR_{G1})^{1/2}$
Gain Resistor R_{G2}	V_{nRG2}	$(4kTR_{G2})^{1/2}$	R_{F2}/R_{G2}	$V_{nO6} = (R_{F2}/R_{G2})(4kTR_{G2})^{1/2}$
Feedback Resistor R_{F1}	V_{nRF1}	$(4kTR_{F1})^{1/2}$	1	$V_{nO7} = (4kTR_{F1})^{1/2}$
Feedback Resistor R_{F2}	V_{nRF2}	$(4kTR_{F2})^{1/2}$	1	$V_{nO8} = (4kTR_{F2})^{1/2}$

Table 12. Differential Input, DC-Coupled

Nominal Gain (dB)	R_F (Ω)	R_G (Ω)	$R_{IN, dm}$ (Ω)	Differential Output Noise Density (nV/ \sqrt{Hz})
6	402	200	400	9.7
10	402	127	254	12.4
14	402	80.6	161	16.6

Table 13. Single-Ended Ground-Referenced Input, DC-Coupled, $R_s = 50 \Omega$

Nominal Gain (dB)	R_F (Ω)	R_{G1} (Ω)	R_T (Ω)	$R_{IN, cm}$ (Ω)	R_{G2} (Ω) ¹	Differential Output Noise Density (nV/ \sqrt{Hz})
6	402	200	60.4	301	228	9.1
10	402	127	66.5	205	155	11.1
14	402	80.6	76.8	138	111	13.5

¹ $R_{G2} = R_{G1} + (R_s || R_T)$.

Similar to the case of a conventional op amp, the output noise voltage densities can be estimated by multiplying the input-referred terms at +IN and –IN by the appropriate output factor, where:

$$G_N = \frac{2}{(\beta_1 + \beta_2)}$$

is the circuit noise gain.

$$\beta_1 = \frac{R_{G1}}{R_{F1} + R_{G1}} \text{ and } \beta_2 = \frac{R_{G2}}{R_{F2} + R_{G2}}$$

are the feedback factors.

When the feedback factors are matched, $R_{F1}/R_{G1} = R_{F2}/R_{G2}$, $\beta_1 = \beta_2 = \beta$, and the noise gain becomes

$$G_N = \frac{1}{\beta} = 1 + \frac{R_F}{R_G}$$

Note that the output noise from V_{OCM} goes to zero in this case. The total differential output noise density, v_{nOD} , is the root-sum-square of the individual output noise terms.

$$v_{nOD} = \sqrt{\sum_{i=1}^8 v_{nOi}^2}$$

Table 12 and Table 13 list several common gain settings, associated resistor values, input impedance, and output noise density for both balanced and unbalanced input configurations.

IMPACT OF MISMATCHES IN THE FEEDBACK NETWORKS

As previously mentioned, even if the external feedback networks (R_F/R_G) are mismatched, the internal common-mode feedback loop still forces the outputs to remain balanced. The amplitudes of the signals at each output remain equal and 180° out of phase. The input-to-output differential mode gain varies proportionately to the feedback mismatch, but the output balance is unaffected.

The gain from the V_{OCM}/V_{OCMx} pin to $V_{O, dm}$ is equal to

$$2(\beta_1 - \beta_2)/(\beta_1 + \beta_2)$$

When $\beta_1 = \beta_2$, this term goes to zero and there is no differential output voltage due to the voltage on the V_{OCM} input (including noise). The extreme case occurs when one loop is open and the other has 100% feedback; in this case, the gain from V_{OCM} input to $V_{O, dm}$ is either +2 or –2, depending on which loop is closed. The feedback loops are nominally matched to within 1% in most applications, and the output noise and offsets due to the V_{OCM} input are negligible. If the loops are intentionally mismatched by a large amount, it is necessary to include the gain term from V_{OCM} to $V_{O, dm}$ and account for the extra noise. For example, if $\beta_1 = 0.5$ and $\beta_2 = 0.25$, the gain from V_{OCM} to $V_{O, dm}$ is 0.67. If the V_{OCM}/V_{OCMx} pin is set to 2.5 V, a differential offset voltage is present at the output of $(2.5 V)(0.67) = 1.67 V$. The differential output noise contribution is $(7.5 \text{ nV}/\sqrt{Hz})(0.67) = 5 \text{ nV}/\sqrt{Hz}$. Both of these results are undesirable in most applications; therefore, it is best to use nominally matched feedback factors.

Mismatched feedback networks also result in a degradation of the ability of the circuit to reject input common-mode signals, much the same as for a four-resistor difference amplifier made from a conventional op amp.

As a practical summarization of the above issues, resistors of 1% tolerance produce a worst-case input CMRR of approximately 40 dB, a worst-case differential-mode output offset of 25 mV due to a 2.5 V V_{OCM} input, negligible V_{OCM} noise contribution, and no significant degradation in output balance error.

CALCULATING THE INPUT IMPEDANCE FOR AN APPLICATION CIRCUIT

The effective input impedance of a circuit depends on whether the amplifier is being driven by a single-ended or differential signal source. For balanced differential input signals, as shown in Figure 44, the input impedance ($R_{IN, dm}$) between the inputs ($+D_{IN}$ and $-D_{IN}$) is simply $R_{IN, dm} = 2 \times R_G$.

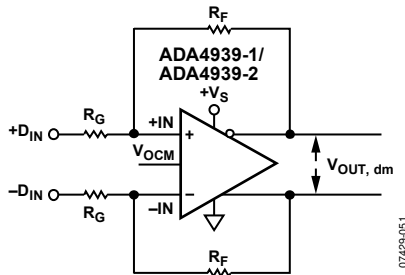

Figure 44. ADA4939-1/ADA4939-2 Configured for Balanced (Differential) Inputs

For an unbalanced, single-ended input signal (see Figure 45), the input impedance is

$$R_{IN, SE} = \left(\frac{R_G}{1 - \frac{R_G}{R_F}} \right)$$

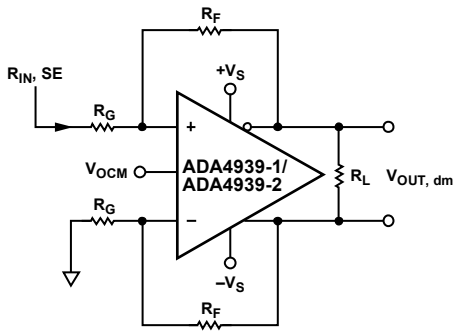

Figure 45. ADA4939-1/ADA4939-2 with Unbalanced (Single-Ended) Input

The input impedance of the circuit is effectively higher than it would be for a conventional op amp connected as an inverter because a fraction of the differential output voltage appears at the inputs as a common-mode signal, partially bootstrapping the voltage across the input resistor R_G . The common-mode voltage at the amplifier input terminals can be easily determined by noting that the voltage at the inverting input is equal to the noninverting output voltage divided down by the voltage divider formed by R_F and R_G in the lower loop. This voltage is present at both input terminals due to negative voltage feedback and is in phase with the input signal, thus reducing the effective voltage across R_G in the upper loop and partially bootstrapping R_G .

Terminating a Single-Ended Input

This section deals with how to properly terminate a single-ended input to the ADA4939-1/ADA4939-2 with a gain of 2, $R_F = 400 \Omega$, and $R_G = 200 \Omega$. An example using an input source with a terminated output voltage of 1 V p-p and source resistance of 50Ω illustrates the four simple steps that must be followed. Note that, because the terminated output voltage of the source is 1 V p-p, the open circuit output voltage of the source is 2 V p-p. The source shown in Figure 46 indicates this open-circuit voltage.

1. The input impedance must be calculated using the formula

$$R_{IN} = \left(\frac{R_G}{1 - \frac{R_G}{R_F}} \right) = \left(\frac{200}{1 - \frac{200}{400}} \right) = 300 \Omega$$

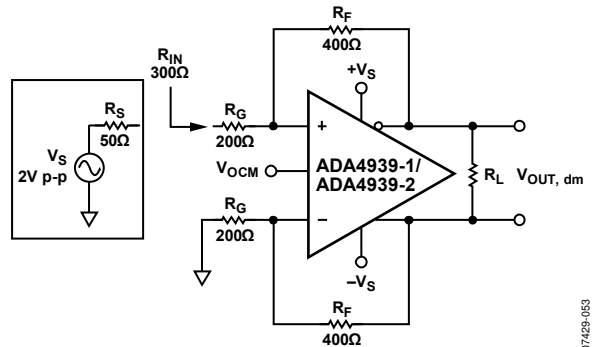

Figure 46. Calculating Single-Ended Input Impedance R_{IN}

- To match the 50 Ω source resistance, the termination resistor, R_T , is calculated using $R_T || 300 \Omega = 50 \Omega$. The closest standard 1% value for R_T is 60.4 Ω.

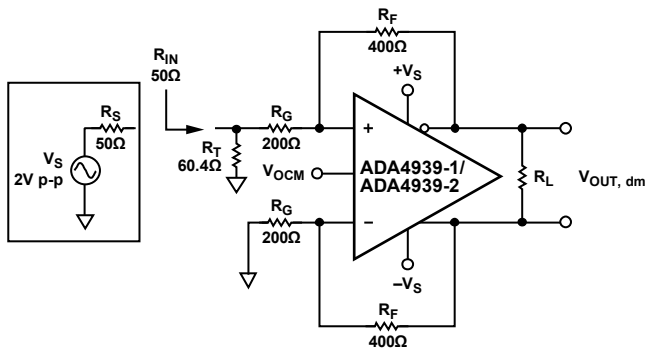

Figure 47. Adding Termination Resistor R_T

- Figure 47 shows that the effective R_G in the upper feedback loop is now greater than the R_G in the lower loop due to the addition of the termination resistors. To compensate for the imbalance of the gain resistors, a correction resistor (R_{TS}) is added in series with R_G in the lower loop. R_{TS} is equal to the Thevenin equivalent of the source resistance R_S and the termination resistance R_T and is equal to $R_S || R_T$.

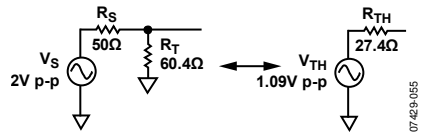

Figure 48. Calculating the Thevenin Equivalent

$R_{TS} = R_{TH} = R_S || R_T = 27.4 \Omega$. Note that V_{TH} is greater than 1 V p-p, which was obtained with $R_T = 50 \Omega$. The modified circuit with the Thevenin equivalent of the terminated source and R_{TS} in the lower feedback loop is shown in Figure 49.

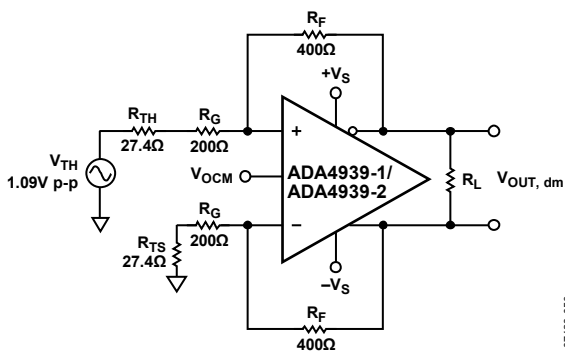

Figure 49. Thevenin Equivalent and Matched Gain Resistors

Figure 49 presents a tractable circuit with matched feedback loops that can be easily evaluated.

It is useful to point out two effects that occur with a terminated input. The first is that the value of R_G is increased in both loops, lowering the overall closed-loop gain. The second is that V_{TH} is a little larger than 1 V p-p, as it would be if $R_T = 50 \Omega$. These two effects have opposite impacts on the output voltage, and for large resistor values in the feedback loops (~1 kΩ), the effects essentially cancel each other out. For small R_F and R_G , however, the diminished closed-loop gain is not canceled completely by the increased V_{TH} . This can be seen by evaluating Figure 49.

The desired differential output in this example is 2 V p-p because the terminated input signal was 1 V p-p and the closed-loop gain = 2. The actual differential output voltage, however, is equal to $(1.09 \text{ V p-p})(400/227.4) = 1.92 \text{ V p-p}$. To obtain the desired output voltage of 2 V p-p, a final gain adjustment can be made by increasing R_F without modifying any of the input circuitry (see Step 4).

- The feedback resistor value is modified as a final gain adjustment to obtain the desired output voltage.

To make the output voltage $V_{OUT} = 2 \text{ V p-p}$, calculate R_F by

$$R_F = \frac{(\text{Desired } V_{OUT, dm})(R_G + R_{TS})}{V_{TH}} = \frac{(2 \text{ V}_{p-p})(227.4 \Omega)}{1.09 \text{ V}_{p-p}} = 417 \Omega$$

The closest standard 1% values to 417 Ω are 412 Ω and 422 Ω. Choosing 422 Ω gives a differential output voltage of 2.02 V p-p.

The final circuit is shown in Figure 50.

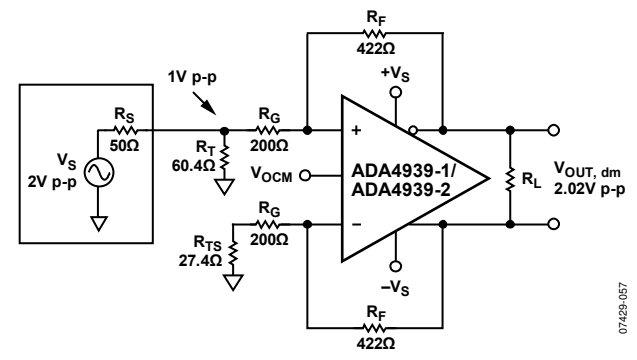

Figure 50. Terminated Single-Ended-to-Differential System with $G = 2$

INPUT COMMON-MODE VOLTAGE RANGE

The ADA4939-1/ADA4939-2 input common-mode range is centered between the two supply rails, in contrast to other ADC drivers with level-shifted input ranges, such as the ADA4937-1/ADA4937-2. The centered input common-mode range is best suited to ac-coupled, differential-to-differential and dual supply applications.

For 5 V single-supply operation, the input common-mode range at the summing nodes of the amplifier is specified as 1.1 V to 3.9 V and is specified as 0.9 V to 2.4 V with a 3.3 V supply. To avoid nonlinearities, the voltage swing at the +IN and –IN terminals must be confined to these ranges.

INPUT AND OUTPUT CAPACITIVE AC COUPLING

Input ac coupling capacitors can be inserted between the source and R_G . This ac coupling blocks the flow of the dc common-mode feedback current and causes the ADA4939-1/ADA4939-2 dc input common-mode voltage to equal the dc output common-mode voltage. These ac coupling capacitors must be placed in both loops to keep the feedback factors matched.

Output ac coupling capacitors can be placed in series between each output and its respective load. See Figure 54 for an example that uses input and output capacitive ac coupling.

MINIMUM R_G VALUE OF 50 Ω

Due to the wide bandwidth of the ADA4939-1/ADA4939-2, the value of R_G must be greater than or equal to 50 Ω to provide sufficient damping in the amplifier front end. In the terminated case, R_G includes the Thevenin resistance of the source and load terminations.

SETTING THE OUTPUT COMMON-MODE VOLTAGE

The V_{OCM}/V_{OCMx} pin of the ADA4939-1/ADA4939-2 is internally biased with a voltage divider comprising two 20 k Ω resistors at a voltage approximately equal to the midsupply point, $[(+V_S) + (-V_S)]/2$. Because of this internal divider, the V_{OCM}/V_{OCMx} pin sources and sinks current, depending on the externally applied voltage and its associated source resistance. Relying on the internal bias results in an output common-mode voltage that is within about 100 mV of the expected value.

In cases where more accurate control of the output common-mode level is required, it is recommended that an external source or resistor divider be used with source resistance less than 100 Ω . The output common-mode offset listed in the Specifications section assumes that the V_{OCM} input is driven by a low impedance voltage source.

It is also possible to connect the V_{OCM} input to a common-mode level (CML) output of an ADC. However, care must be taken to ensure that the output has sufficient drive capability. The input impedance of the V_{OCM}/V_{OCMx} pin is approximately 10 k Ω . If multiple ADA4939-1/ADA4939-2 devices share one reference output, it is recommended that a buffer be used.

LAYOUT, GROUNDING, AND BYPASSING

As a high speed device, the ADA4939-1 is sensitive to the PCB environment in which it operates. Realizing its superior performance requires attention to the details of high speed PCB design. This section shows a detailed example of how the ADA4939-1 was addressed.

The first requirement is a solid ground plane that covers as much of the board area around the ADA4939-1 as possible. However, the area near the feedback resistors (R_F), gain resistors (R_G), and the input summing nodes (Pin 2 and Pin 3) must be cleared of all ground and power planes (see Figure 51). Clearing the ground and power planes minimizes any stray capacitance at these nodes and prevents peaking of the response of the amplifier at high frequencies.

The thermal resistance, θ_{JA} , is specified for the device, including the exposed pad, soldered to a high thermal conductivity four-layer circuit board, as described in EIA/JESD 51-7.

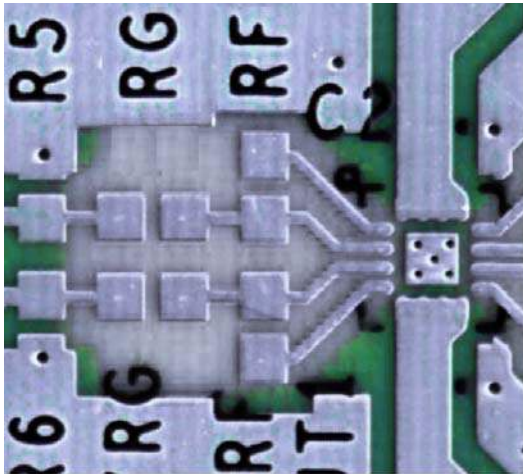

Figure 51. Ground and Power Plane Voiding in Vicinity of R_F and R_G

Bypass the power supply pins as close to the device as possible and directly to a nearby ground plane. Use high frequency ceramic chip capacitors. It is recommended to use two parallel bypass capacitors (1000 pF and 0.1 μ F) for each supply. Place the 1000 pF capacitor closer to the device. Further away, provide low frequency bypassing, using 10 μ F tantalum capacitors from each supply to ground.

Ensure that signal routing is short and direct to avoid parasitic effects. Wherever complementary signals exist, provide a symmetrical layout to maximize balanced performance. When routing differential signals over a long distance, ensure that the PCB traces are close together, and twist any differential wiring such that the loop area is minimized which reduces radiated energy and makes the circuit less susceptible to interference.

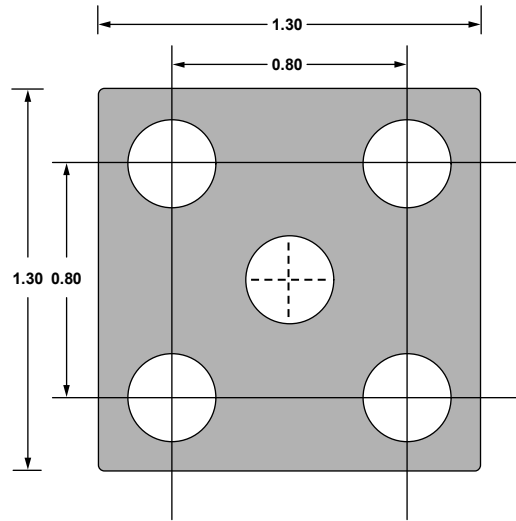

Figure 52. Recommended PCB Thermal Attach Pad Dimensions (Millimeters)

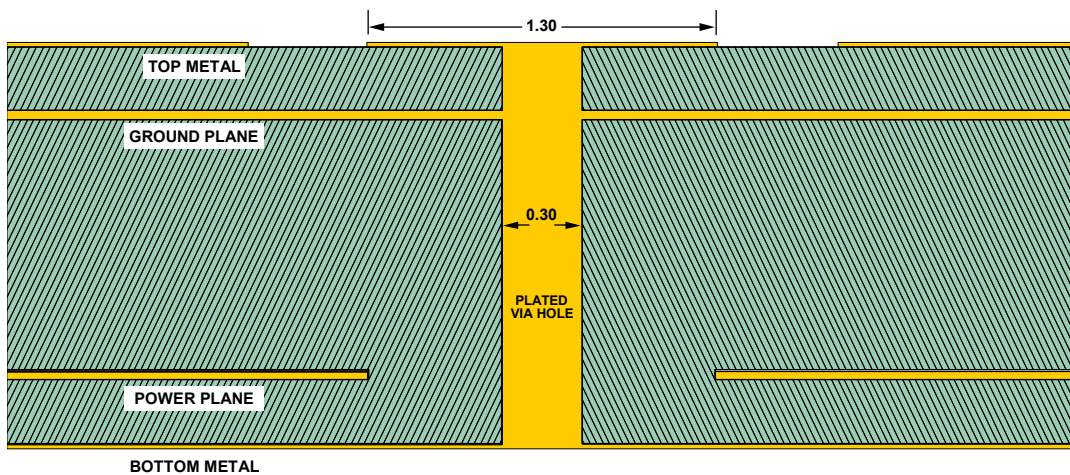

Figure 53. Cross-Section of 4-Layer PCB Showing Thermal Via Connection to Buried Ground Plane (Dimensions in Millimeters)

HIGH PERFORMANCE ADC DRIVING

The ADA4939-1/ADA4939-2 are ideally suited for broadband ac-coupled and differential-to-differential applications on a single supply.

The circuit in Figure 54 shows a front-end connection for an ADA4939-1 driving an AD9445, 14-bit, 105 MSPS ADC, with ac coupling on the ADA4939-1 input and output. (The AD9445 achieves its optimum performance when driven differentially.) The ADA4939-1 eliminates the need for a transformer to drive the ADC and perform a single-ended-to-differential conversion and buffering of the driving signal.

The ADA4939-1 is configured with a single 5 V supply and gain of 2 for a single-ended input to differential output. The 60.4 Ω termination resistor, in parallel with the single-ended input impedance of approximately 300 Ω , provides a 50 Ω termination for the source. The additional 27.4 Ω (227.4 Ω total) at the inverting input balances the parallel impedance of the 50 Ω source and the termination resistor driving the noninverting input.

In this example, the signal generator has a 1 V p-p symmetric, ground-referenced bipolar output when terminated in 50 Ω .

The V_{OCM} pin of the ADA4939-1 is bypassed for noise reduction and left floating such that the internal divider sets the output common-mode voltage nominally at midsupply. Because the inputs are ac-coupled, no dc common-mode current flows in the feedback loops, and a nominal dc level of midsupply is present at the amplifier input terminals. Besides placing the amplifier inputs at their optimum levels, the ac coupling technique lightens the load on the amplifier and dissipates less power than applications with dc-coupled inputs. With an output common-mode voltage of nominally 2.5 V, each ADA4939-1 output swings between 2.0 V and 3.0 V, providing a gain of 2 and a 2 V p-p differential signal to the ADC input.

The output of the amplifier is ac-coupled to the ADC through a second-order, low-pass filter with a cutoff frequency of 100 MHz. This reduces the noise bandwidth of the amplifier and isolates the driver outputs from the ADC inputs.

The AD9445 is configured for a 2 V p-p full-scale input by connecting the SENSE pin to AGND, as shown in Figure 54.

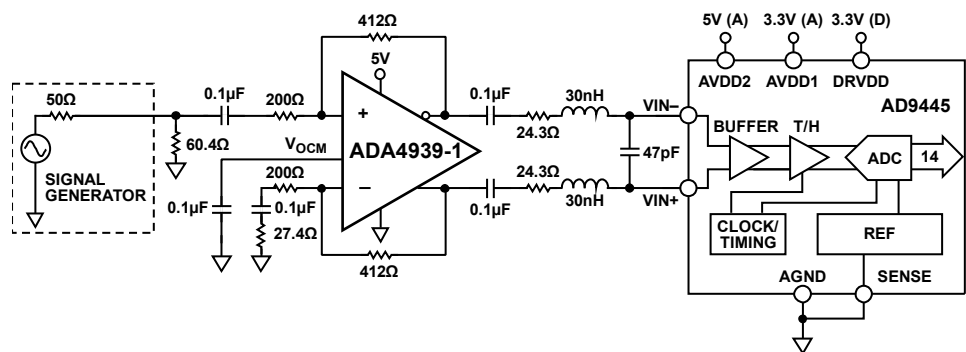
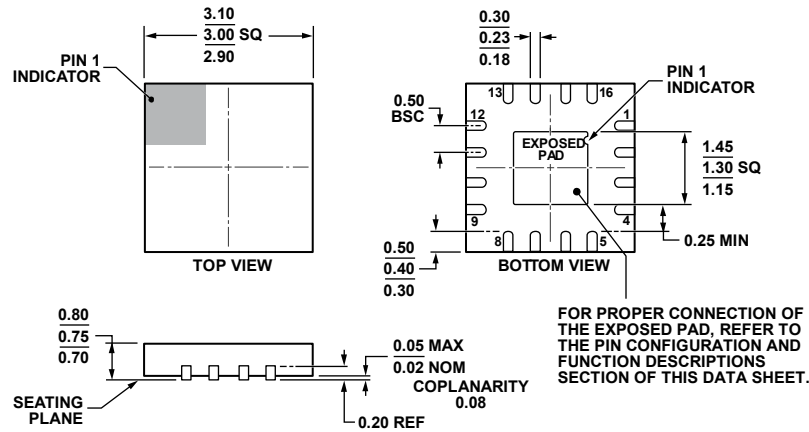

Figure 54. ADA4939-1 Driving an AD9445 ADC with AC-Coupled Input and Output

OUTLINE DIMENSIONS



COMPLIANT TO JEDEC STANDARDS MO-220-WEED.

Figure 55. 16-Lead Lead Frame Chip Scale Package [LFCSP]
3 mm × 3 mm Body and 0.75 mm Package Height
(CP-16-21)

Dimensions shown in millimeters

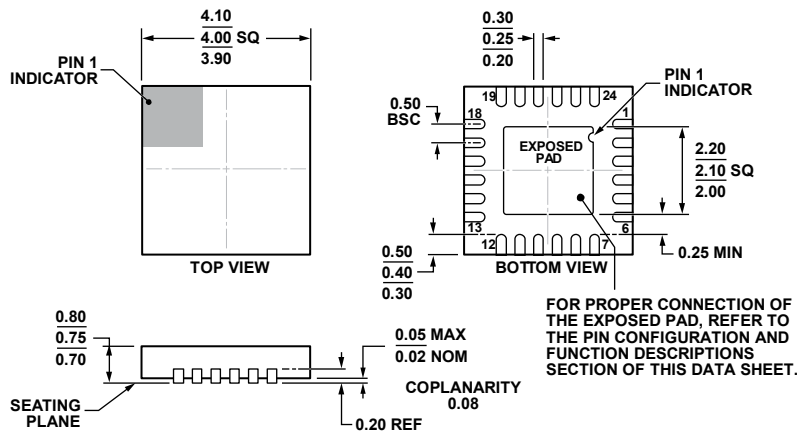

COMPLIANT TO JEDEC STANDARDS MO-220-WGGD-8.

Figure 56. 24-Lead Lead Frame Chip Scale Package [LFCSP]
4 mm × 4 mm Body and 0.75 mm Package Height
(CP-24-10)

Dimensions shown in millimeters

ORDERING GUIDE

Model ¹	Temperature Range	Package Description	Package Option	Ordering Quantity	Branding
ADA4939-1YCPZ-R2	-40°C to +105°C	16-Lead LFCSP	CP-16-21	250	H1E
ADA4939-1YCPZ-RL	-40°C to +105°C	16-Lead LFCSP	CP-16-21	5,000	H1E
ADA4939-1YCPZ-R7	-40°C to +105°C	16-Lead LFCSP	CP-16-21	1,500	H1E
ADA4939-2YCPZ-R2	-40°C to +105°C	24-Lead LFCSP	CP-24-10	250	
ADA4939-2YCPZ-RL	-40°C to +105°C	24-Lead LFCSP	CP-24-10	5,000	
ADA4939-2YCPZ-R7	-40°C to +105°C	24-Lead LFCSP	CP-24-10	1,500	

¹ Z = RoHS Compliant Part.