

QUICK START GUIDE FOR DEMONSTRATION CIRCUIT 427B RMS TO DC CONVERTER

LTC1966/LTC1967/LTC1968

DESCRIPTION

Demonstration circuit 427B features the LTC1966/7/8 Precision Micro-power true RMS-to-DC converter. It incorporates a variety of passive components to support configurations for varied applications. Two optional post-filters are included to improve averaging ripple and step response performance, as illustrated in the Design Cookbook section of the datasheet. DC427B-A contains the LTC1966, DC427B-B contains the LTC1967, and DC427B-C contains the LTC1968.

The LTC1966/7/8 is a patent-pending $\Delta\Sigma$ -based RMS to DC converter that is simpler, more accurate, more flexible,

and lower power than conventional log-antilog RMS-to-DC converters. The LTC1966/7/8 accepts single-ended or differential inputs with rail-to-rail common-mode range. One standout feature of the LTC1966/7/8 is its superior linearity, which allows hassle-free system calibration at any input voltage.

Design files for this circuit board are available. Call the LTC factory.

 , LTC and LT are registered trademarks of Linear Technology Corporation.

QUICK START PROCEDURE

Table 1 shows the Jumper positions and their respective effects. Be sure that the jumpers are in the **bold** (default) positions. Refer to Figure 1 for the connection diagram and follow the procedure below:

1. Connect the power supplies as shown. The power labels of V_{SS} and V_{DD} directly correspond to pins 4 and 7 of the LTC1966/7/8, respectively, and combinations other than $\pm 5V$ may be used. The LTC1966 accepts dual $\pm 5V$ supplies, and the LTC1967/8 accept single 5V supplies; refer to the respective datasheet and the Supply Voltages section of this Quick Start Guide.

2. Apply an input signal to convert from RMS to DC to IN1. Any signal generator may be used; the LTC1966 works up to $1V_{PEAK}$ with $V_{DD} = 5V$.

NOTE: There is a 50Ω termination to ground on DC427B; remove if driving IN1 or IN2 with an op-amp.

3. Observe the output with a digital voltmeter (DVM) connected to terminals E4 and E7.

NOTE: The LTC1966/7/8 output impedance is high, and $10M\Omega$ DVM input impedance will cause up to -1% gain error.

4. To use the optional output filters, reposition JP3 and observe the output at terminal E1 or E8.

Table 1: DC427B Jumpers (default positions in bold)

JUMPER	SETTING	EFFECT
JP1	Top	LTC1966/7/8 shutdown
	Bottom	LTC1966/7/8 always enabled
	Removed	LTC1966/7/8 controlled by E2 input to DC427
JP2	Left	IN1 grounded
	Right	IN1 active (J1 connected to pin 2)
JP3	Top	Vout (pin 5) connected to optional DC-Accurate post-filter
	Right	Vout connected to output terminal E4, no filter
	Bottom	Vout connected to optional buffered post-filter
JP4	Left	IN2 grounded
	Right	IN2 active (J2 connected to pin 3)
JP5	Top	OutRtn (pin 6) grounded
	Bottom	OutRtn connected to VSS
	Removed	OutRtn floating; drive with voltage at terminal E7
JP6	Left	LTC1966/7/8 negative supply (Pin 1) connected to VSS
	Right	Pin 1 grounded

QUICK START GUIDE FOR DEMONSTRATION CIRCUIT 427B RMS TO DC CONVERTER

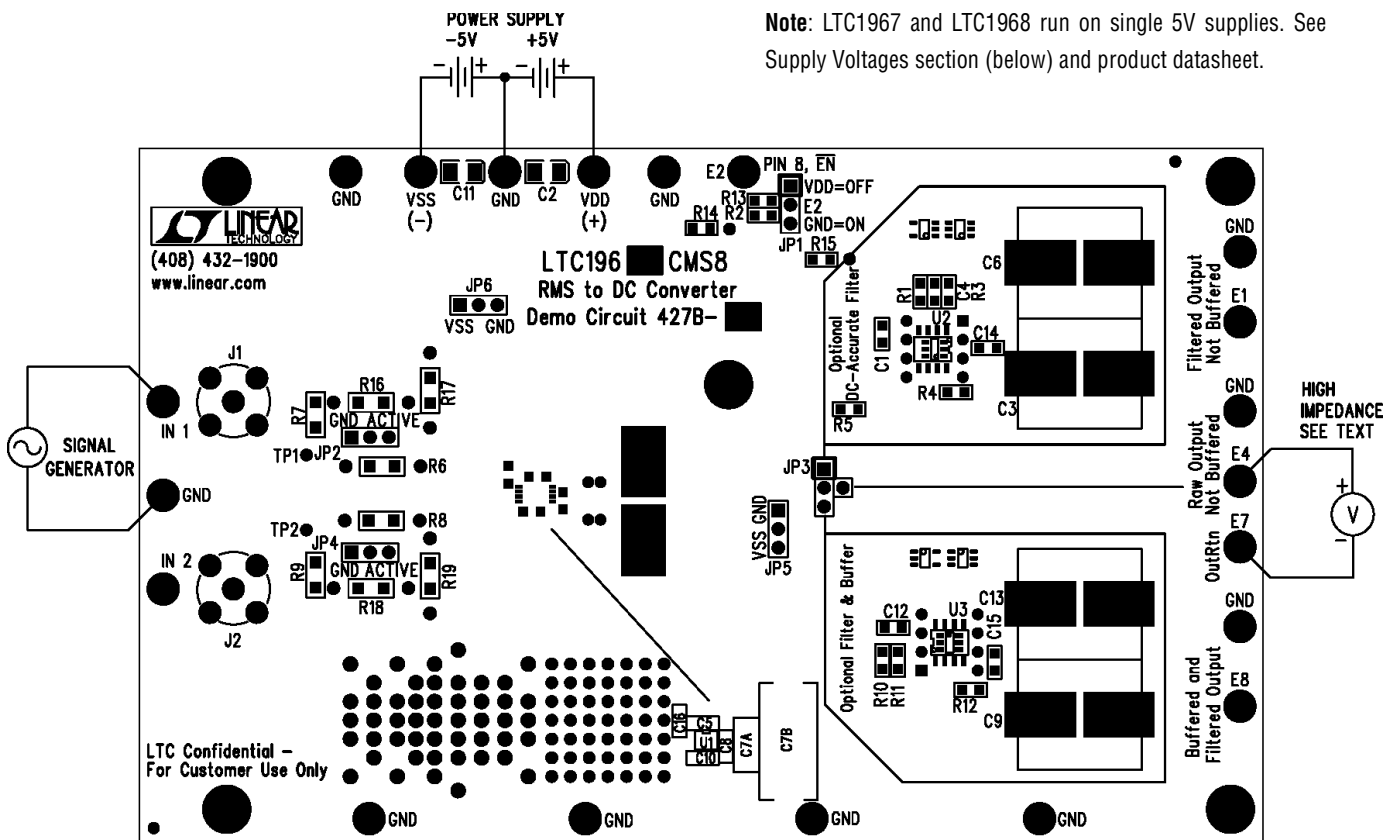

Figure 1. Proper Measurement Equipment Setup

ADDITIONAL FEATURES

Although the 427B demo board is ready to use out of the box (See “Quick Start Procedure” above), it has features that you can access by adding, removing or changing components on the board. Here are some ways that you can change the configuration to take advantage of these features.

DIFFERENTIAL INPUTS

To drive the input differentially, move jumper JP4 from left to right. The LTC1966/7/8 will respond to the difference of the signals. If two different frequencies are used, the vector sum results.

AVERAGING CAPACITORS

The board provides space for trying out different averaging (and filtering) capacitors. The space at C7B parallels C7A (the included metal film averaging capacitor). The space

Note: LTC1967 and LTC1968 run on single 5V supplies. See Supply Voltages section (below) and product datasheet.

has a footprint that will accommodate 2.5mm, 5mm, 7.5mm, and 10mm spaced through-hole leaded components as well as a large solder mask-free area for use with a wide variety of surface mount case sizes. Try out the averaging capacitor you intend to use with the LTC1966/7/8 in 427B.

SUPPLY VOLTAGES

The LTC1967/8 are single 5V supply converters. V_{DD} and V_{SS} on the DC427B connect to Pin 7 and Pin 4 of the IC, but the supply pins of the LTC1967/8 are Pin 7 and Pin 1 (Pin 4 is NC). On the DC427B-B and DC427B-C, use JP6 to select whether the negative supply voltage of the LTC1967/8 will be VSS or ground.

QUICK START GUIDE FOR DEMONSTRATION CIRCUIT 427B

RMS TO DC CONVERTER

FILTER OP AMPS

Likewise, the layout of the U2/U3 Op Amps includes active locations for SOT-23, MS-8, SO-8 and DIP-8 single Op Amp packages. Try out the Op Amp you intend to use in such filters using DC427B. Normally unused pins of the Op Amps (1, 5, and 8 in the 8-lead packages) are all tied in parallel, i.e. pin 8 of the DIP is tied to pin 8 of the SO and pin 8 of the MS. Pin 5 of the SOT-6 is tied to pin 5 of the other packages as well. If using any of these pins (for shutdown control, nulling, compensation, etc) the DIP-8 through-hole pins will likely be the easiest place to connect to them.

NOTE: The MS-8 and DIP-8 are located on the back (solder) side of the board. Using the back side for these parts is not advised for production.

AC COUPLING

Resistors R6 and R8 put 10k Ω between the LTC1966/7/8 and the signals driving DC427B. With 50 Ω signal generators, these are not needed, but they are helpful when driving DC427 with standard Op Amps whose output stages can get confused by the fast spikes of current drawn by the LTC1966/7/8's CMOS inputs (described in the datasheet). Another important reason for including R6/R8 is the ability to change one of them to a capacitor to provide AC coupling. Select a 1206 case size capacitor as described in the LTC1966/7/8 datasheet.

KELVIN-SENSE POINTS

The LTC1966/7/8 has a typical conversion gain accuracy of $\pm 0.1\%$. Measuring this accuracy can be difficult. The primary challenge is getting a known good accurate input signal to the LTC1966/7/8 without corrupting it with para-

sitics. In a 50 Ω environment, even 0.05 Ω in series will result in a 0.1% attenuation of the signal. Of course many 50 Ω terminators are $\pm 1\%$ tolerance, including R7 & R9 on DC427B. To compensate for these effects, the signal at the LTC1966 inputs can be Kelvin-sensed. But parasitic capacitance can corrupt the LTC1966 sampling or the LTC1966 sampling can reduce the sensed signal level, depending on the exact impedance and parasitic levels. The preferred method is to sense at the outside of series feed resistors R6 and R8, at the test points TP1 and TP2 located to the left of R6 and R8. For a further discussion of the LTC1966/7/8 input sampling, refer to the "Input Impedance" information in the "Application Information" section of the datasheet.

JACKS AND TURRETS

Connectors J1 and J2 allow installation of a BNC jack, such as CONNEX type 112404.

The various holes around the periphery of the board allow the installation of turrets such as MILL-MAX type 2501-2. However, the size and placement of the holes allow clip lead connections without installing the turrets.

SHUTDOWN

Finally, by removing jumper JP1, the LTC1966/7/8 ENABLE pin may be driven externally through E2.

NOTE: The LT1494 Op-Amps and the R1/R3 divider network will continue to draw current even when the LTC1966/7/8 is disabled. To measure the near-zero current of the LTC1966, remove zero- Ω shunts R14 and R15. These can also be removed to power the optional filters with different supply voltages than the LTC1966/7/8.

QUICK START GUIDE FOR DEMONSTRATION CIRCUIT 427B RMS TO DC CONVERTER

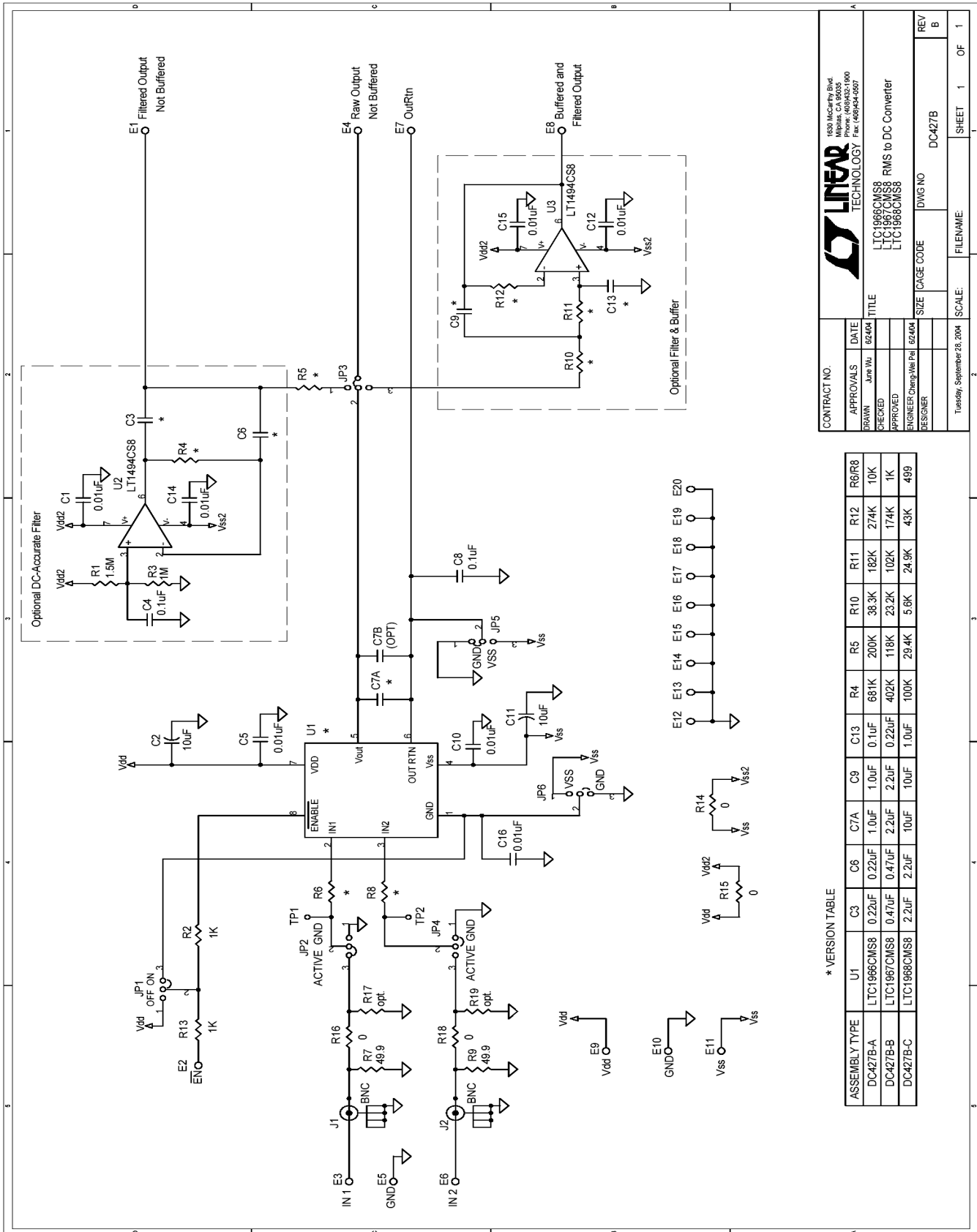

CONTRACT NO.		DATE	
APPROVALS	DATE	APPROVALS	DATE
DRAWN	June Wu	6/24/04	
CHECKED			
APPROVED			
ENGINEER	Cheng-Wen Pao	6/24/04	
DESIGNER			
TITLE		SCALE	
LTC1966CMS8 LTC1967CMS8 LTC1968CMS8 RMS to DC Converter		Tuesday, September 28, 2004	
SIZE		FILENAME	
CASE CODE		DC427B	
DWG NO		REV	
		B	
		1 OF 1	

* VERSION TABLE

ASSEMBLY TYPE	U1	C3	C6	C7A	C9	R4	R5	R10	R11	R12	R6/R8
DC427B-A	LTC1966CMS8	0.22uF	0.22uF	1.0uF	1.0uF	881K	200K	38.3K	182K	274K	10K
DC427B-B	LTC1967CMS8	0.47uF	0.47uF	2.2uF	2.2uF	402K	118K	23.2K	102K	174K	1K
DC427B-C	LTC1968CMS8	2.2uF	2.2uF	10uF	10uF	100K	29.4K	5.6K	24.9K	43K	499