

# Surface Mount Power Splitter/Combiner

## SCP-4-4-75+

4 Way-0° 75Ω

10 to 1000 MHz



Generic photo used for illustration purposes only  
CASE STYLE: YY161

**+RoHS Compliant**

The +Suffix identifies RoHS Compliance. See our web site for RoHS Compliance methodologies and qualifications

### Maximum Ratings

Operating Temperature	-40°C to 85°C
Storage Temperature	-55°C to 100°C
Power Input (as a splitter)	1W max.
Internal Dissipation	0.375W max.

Permanent damage may occur if any of these limits are exceeded.

### Pin Connections

SUM PORT	3
PORT 1	2
PORT 2	4
PORT 3	6
PORT 4	8
GROUND	1,5,7

### Outline Drawing

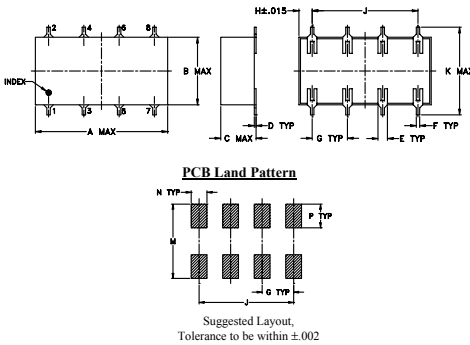

### Outline Dimensions (inch/mm)

	A	B	C	D	E	F	G
	0.75	0.38	0.28	0.01	0.05	0.02	0.2
	19.05	9.65	7.11	0.25	1.27	0.51	5.08
	H	J	K	M	N	P	wt
	0.075	0.6	0.45	0.47	0.1	0.15	grams
	1.91	15.24	11.43	11.94	2.54	3.81	1.60

### Demo Board MCL P/N: TB-184 Suggested PCB Layout (PL-175)

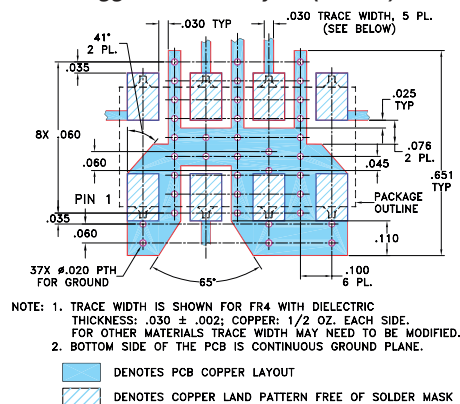

### Notes

- Performance and quality attributes and conditions not expressly stated in this specification document are intended to be excluded and do not form a part of this specification document.
- Electrical specifications and performance data contained in this specification document are based on Mini-Circuit's applicable established test performance criteria and measurement instructions.
- The parts covered by this specification document are subject to Mini-Circuit's standard limited warranty and terms and conditions (collectively, "Standard Terms"); Purchasers of this part are entitled to the rights and benefits contained therein. For a full statement of the Standard Terms and the exclusive rights and remedies thereunder, please visit Mini-Circuit's website at [www.minicircuits.com/MCLStore/terms.jsp](http://www.minicircuits.com/MCLStore/terms.jsp)

### Features

- wideband, 10 to 1000 MHz
- high isolation, 32 dB typ
- excellent amplitude unbalance, 0.4 dB typ.

### Applications

- cellular
- CATV
- receivers/transmitters

### Electrical Specifications

FREQ. RANGE (MHz)	ISOLATION (dB)			INSERTION LOSS (dB) ABOVE 6 dB			PHASE UNBALANCE (Degrees)			AMPLITUDE UNBALANCE (dB)								
	L	M	U	L	M	U	L	M	U	L	M	U						
$f_L$ - $f_U$	Typ. Min.	Typ. Min.	Typ. Min.	Typ. Max.	Typ. Max.	Typ. Max.	Max.	Max.	Max.	Max.	Max.	Max.						
10-1000	36	20	32	18	24	14	0.5	1.0	0.65	1.3	0.8	2.0	3	6	12	0.2	0.4	0.9

L = low range [ $f_L$  to 10  $f_L$ ] M = mid range [10  $f_L$  to  $f_U/2$ ] U = upper range [ $f_U/2$  to  $f_U$ ]

### Typical Performance Data

Freq. (MHz)	Total Loss <sup>1</sup> (dB)				Amp. Unbal. (dB)	Isolation (dB)			Phase Unbal. (deg.)	VSWR S	VSWR 1	VSWR 2	VSWR 3	VSWR 4
	S-1	S-2	S-3	S-4		1-2	2-3	3-4						
10.00	6.56	6.48	6.57	6.50	0.09	26.09	39.05	25.95	0.09	1.11	1.27	1.27	1.28	1.28
28.00	6.58	6.51	6.59	6.53	0.08	25.99	39.79	25.80	0.07	1.11	1.26	1.26	1.27	1.27
82.00	6.63	6.56	6.64	6.58	0.08	25.86	38.34	25.94	0.11	1.11	1.27	1.27	1.28	1.26
125.00	6.66	6.58	6.65	6.58	0.08	26.12	37.42	26.25	0.20	1.11	1.27	1.27	1.27	1.26
200.00	6.71	6.64	6.71	6.63	0.08	26.87	35.99	26.84	0.20	1.10	1.26	1.27	1.27	1.26
275.00	6.73	6.67	6.74	6.63	0.11	27.64	34.09	27.28	0.26	1.10	1.25	1.26	1.26	1.25
350.00	6.72	6.68	6.75	6.65	0.10	27.84	31.86	27.36	0.27	1.10	1.25	1.26	1.25	1.24
425.00	6.80	6.77	6.80	6.68	0.13	27.09	29.59	26.76	0.34	1.10	1.24	1.25	1.24	1.22
500.00	6.85	6.82	6.85	6.71	0.15	25.59	27.43	25.69	0.37	1.08	1.22	1.24	1.22	1.21
575.00	6.90	6.89	6.88	6.73	0.17	23.96	25.56	24.52	0.52	1.07	1.21	1.22	1.20	1.19
650.00	6.98	6.99	6.95	6.78	0.22	22.67	23.98	23.58	0.59	1.07	1.19	1.21	1.18	1.17
750.00	7.07	7.14	7.06	6.85	0.29	21.62	22.43	23.02	0.94	1.09	1.17	1.20	1.17	1.15
850.00	7.16	7.28	7.14	6.89	0.39	21.38	21.37	23.46	1.76	1.13	1.18	1.22	1.18	1.15
950.00	7.27	7.45	7.23	6.92	0.52	21.57	20.80	24.89	2.57	1.14	1.21	1.26	1.22	1.17
1000.00	7.32	7.55	7.29	6.96	0.59	21.44	20.64	25.48	3.07	1.13	1.24	1.29	1.25	1.21

1. Total Loss = Insertion Loss + 6dB splitter loss.

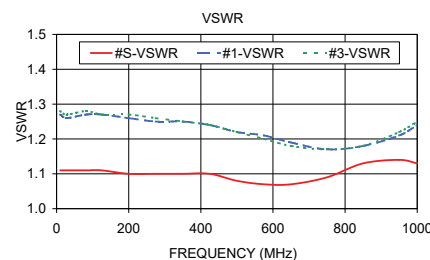
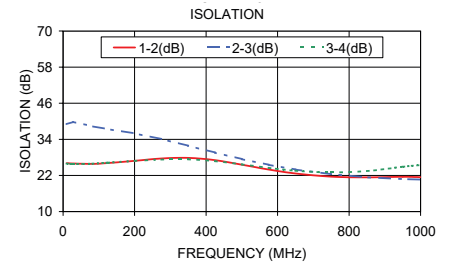
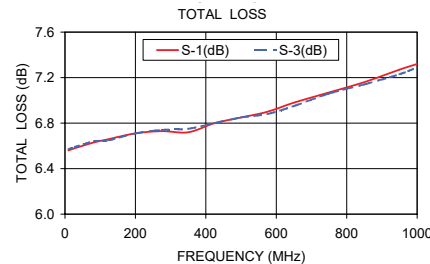

### Electrical Schematic

